

~~max 11) sec III  
310-31 4 Jan 56~~

TM 9-456

~~DA~~

**WAR DEPARTMENT**

**TECHNICAL MANUAL**

**12-INCH SEACOAST MATERIEL**

**12-INCH MORTAR M1890MI**

**- MOUNTED ON**

**12-INCH MORTAR CARRIAGE M1896MI AND M1896MII**

**OCTOBER 17, 1942**

AUG 24 1943

TECHNICAL MANUAL }  
No. 9-456 }

U. S. Property

\*TM 9-456

WAR DEPARTMENT,  
Washington, October 17, 1942

# 12-INCH SEACOAST MATERIEL

## 12-INCH MORTAR M1890MI MOUNTED ON 12-INCH MORTAR CARRIAGE M1896MI AND M1896MII

Prepared under the direction of the  
Chief of Ordnance

### CONTENTS

SECTION		Paragraphs	Pages
I:	Introduction .....	1- 3	3- 11
II:	Description of mortar .....	4- 6	12- 20
III:	Description of carriage .....	7-14	21- 35
IV:	Operation .....	15-22	36- 46
V:	Malfunction and correction ....	23-24	47- 49
VI:	Care and preservation .....	25-33	50- 67
VII:	Inspection and adjustment ....	34-43	68- 75
VIII:	Repair .....	44-45	76
IX:	Ammunition .....	46-60	77-101
X:	Organization spare parts and accessories .....	61-75	102-113
XI:	Subcaliber equipment .....	76-80	114-119
XII:	Painting .....	81-85	120-123
XIII:	Materiel affected by gas .....	86-88	124-126
XIV:	References .....	89-92	127-128
INDEX	.....		129-136

\* This TM supersedes in part: WD 1075, Service Handbook of the Mortar Carriages, Model of 1896MI and 1896MII for 12-inch Mortars, Model of 1890MI; WD 1024, Instructions for Mounting, Using, and Caring for Mortar Carriages Model of 1896MI and Model of 1896MII for 12-inch Mortars Model of 1890MI, July 6, 1920; ORD 1820, Description of 12-inch Mortars and Instructions for their Care, June 5, 1917; and ORD 1986, Directions for Using, Mounting, and Dismounting 1-Pounder and 2.95-inch Subcaliber Guns in the Bore of Seacoast Guns and Mortars and Instructions for Using the Reloading and Resizing Outfit for Drill Primers, Aug. 8, 1914.

9030662

TM 9-456

12-INCH SEACOAST MATERIEL

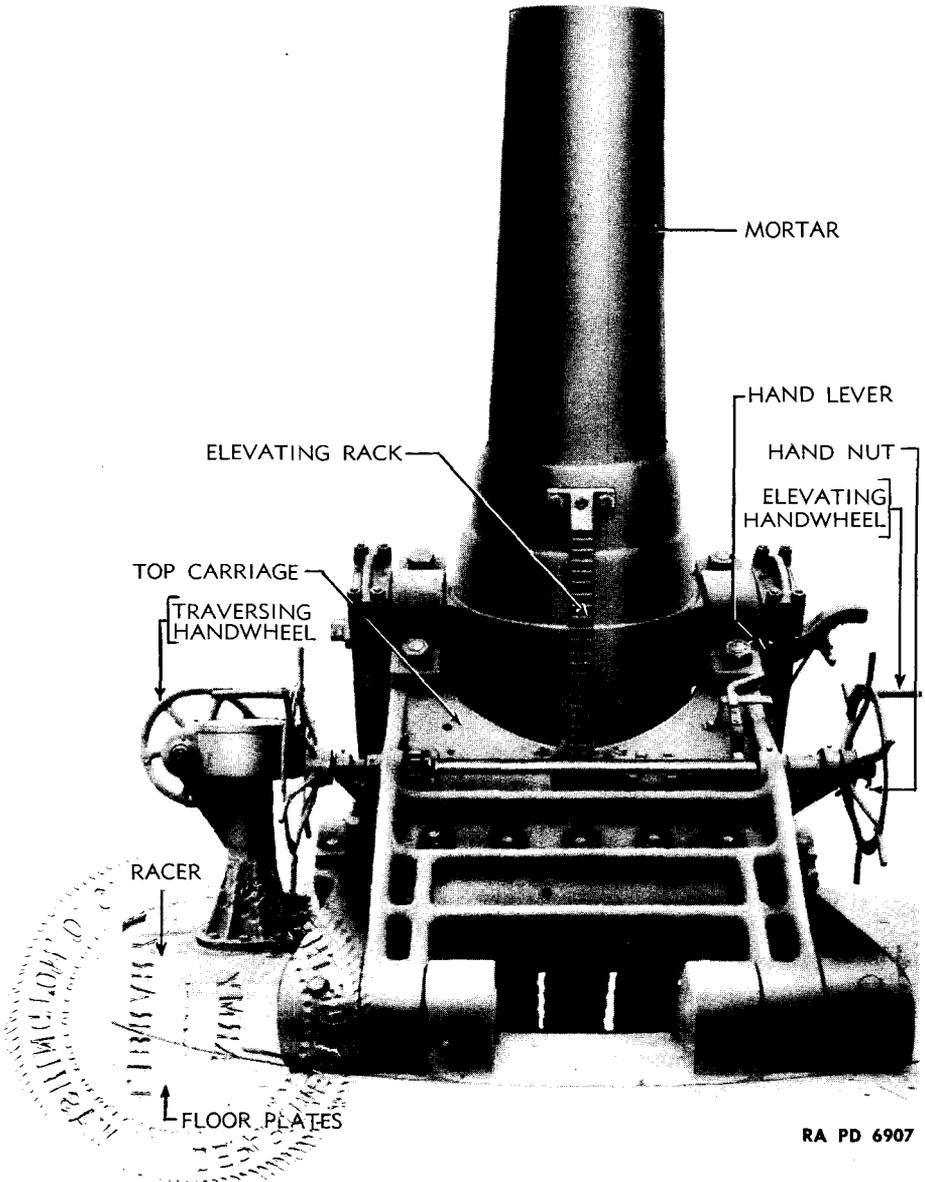

RA PD 6907

Frontispiece—12-Inch Mortar M1890MI Mounted on Mortar Carriage M1896MI and M1896MI

Section I

**INTRODUCTION**

	Paragraph
Scope .....	1
Characteristics .....	2
Data .....	3

**1. SCOPE.**

a. This manual is published for the information and guidance of the using arms and services.

b. There is included technical information required for identification, use, and care of the 12-inch mortar M1890MI and mortar carriages M1896MI and M1896MII. This information is presented from the standpoint of personnel in the field, whose responsibilities may be divided into three main classes: operation, service, and repair. Sections I to VIII cover the routine operation, service, and repair of the mortar and mount. Complete instructions for routine operation, service, and repair of the organization equipment (except sighting and fire control equipment) and for care and preparation of ammunition are included in sections IX through XII. Section XIII covers operation and service of all the materiel under unusual conditions.

c. Instructions for the care and use of the sighting and fire control instruments are not included in this manual but are covered in FM 4-15.

**2. CHARACTERISTICS.**

a. These 12-inch mortars are comparatively short-barreled weapons, able to fire in all directions (360 deg traverse) but only at high angles of elevation. The maximum elevation attainable is 70 degrees. The minimum elevation (just clearing the emplacement walls) is 45 degrees. The weapon must be depressed to zero degrees between rounds for loading. These mortars are no longer manufactured.

**3. DATA.**

**a. 12-Inch Mortar M1890MI.**

Length, over-all .....	161 inches
Length, muzzle to breech face .....	141.125 inches
Length of bore in calibers .....	10
Maximum diameter of chamber .....	12.5 inches
Weight, including breech mechanism .....	29,120 pounds
Type of construction .....	Built-up

**12-INCH SEACOAST MATERIEL**

**Rifling:**

Twist .....	Right-hand increasing from 1 turn in 40 cali- bers to 1 turn in 20 calibers
Number of grooves .....	72
Groove, width .....	0.3736 inches
Groove, depth .....	0.06 inches
Land, width .....	0.15 inches
Type of breechblock, translating roller type (tray-supported) .....	Slotted screw
Type of firing mechanism .....	Friction and electric
Model of firing mechanism .....	Seacoast firing mecha- nism M1903
Number of handles to operate breechblock ..	2
Power .....	Hand
Muzzle velocity, maximum (700-lb projectile —Zone 9) .....	1,500 feet per second
Muzzle velocity, maximum (1,046-lb projec- tile—Zone 7) .....	1,050 feet per second
Range, maximum (700-lb shell) .....	14,610 yards
Range, minimum (1,026-lb shell) .....	2,400 yards
Life of mortar (full charge) .....	1,500 rounds
Rate of fire (normal) .....	60 seconds per round
Rate of fire (maximum) .....	45 seconds per round

**b. 12-Inch Mortar Carriage M1896MI and M1896MII.**

Type .....	Mortar
Total weight M1896MI and M1896MII ....	128,000 pounds
Total weight .....	64 tons
<b>Elevating mechanism:</b>	
Type .....	Spur
Power .....	Hand
Elevation per turn of handwheel .....	9.46 degrees
Elevation for firing (maximum) .....	70.00 degrees
Elevation for firing (minimum) .....	45.00 degrees
Elevation for loading .....	0.00 degrees
Method of reducing friction in trunnions ..	Bushing
<b>Traversing mechanism:</b>	
Type of bearing .....	Roller
Mean diameter of roller path .....	12¼ feet

**INTRODUCTION**

Traverse per turn of handwheel . . . . .	2.4 degrees
Maximum traverse . . . . .	360 degrees
Base ring, outer flange diameter . . . . .	7 feet
Racer diameter, M1896MI . . . . .	164.5 inches
Racer diameter, M1896MII . . . . .	165.25 inches

**Recoil mechanism:**

Type . . . . .	Hydraulic
Number of cylinders . . . . .	2
Length of recoil M1896MI . . . . .	23 inches
Length of recoil M1896MII . . . . .	24 inches
Orifices . . . . .	Grooves
Buffer . . . . .	Dashpot
Recoil oil . . . . .	OIL, recoil, light
Recoil oil capacity . . . . .	9½ gallons

**Recuperating mechanism:**

Type . . . . .	Five columns of springs
Force holding mortar in battery . . . . .	45 tons
Sections per column (Each section consists of an inner and an outer spring) . . . . .	5

**Electrical data:****Lighting circuit**

Power M1896MI . . . . .	110 and 220 volts, D.C.
M1896MII . . . . .	110 volts, D. C.
Lamps, type (azimuth and quadrant) . . . . .	Electric bayonet base, double contact, frosted bulb, 8 C.P., 12-16 volt
Switch . . . . .	5 amp double pole

**Firing circuit**

Power . . . . .	Magneto-type MA
-----------------	-----------------

**c. Sighting and Fire Control Instruments.**

(1) The sighting equipment supplied with this mortar may include the following instruments:

- (a) Clinometer
- (b) Quadrant, elevation
- (c) Bore rest, clinometer
- (d) Quadrant, gunner's
- (e) Sight, bore

(2) The fire control equipment supplied with this mortar may include the following instruments. At various harbor defenses the model of any

**12-INCH SEACOAST MATERIEL**

one item may vary. It is also possible that some of the items listed below may not be used at a particular battery.

- (a) Arm, scale, M1906
- (b) Board, adjustment
- (c) Board, correction, range
- (d) Board, deflection, mortar
- (e) Board, plotting, mortar
- (f) Board, spotting
- (g) Corrector, percentage
- (h) Finder, depression position
- (i) Indicator, wind component
- (j) Instrument, azimuth
- (k) Rule, set forward
- (l) Scale, prediction
- (m) Telescope, observation

**d. Subcaliber Gun (2.95-in.).**

Weight of subcaliber tube . . . . .	224 pounds
Caliber . . . . .	2.953 inches
Length of bore, including chamber . . . . .	31.6 inches
Length of rifled portion of bore . . . . .	24.33 inches
Rifling, uniform, 1 turn in 25 calibers, right-hand twist:	
Number of grooves . . . . .	30
Width of grooves . . . . .	0.23 inch
Depth of grooves . . . . .	0.023 inch
Capacity of powder chamber . . . . .	34.9 cubic inches
Weight of projectile . . . . .	18 pounds
Weight of cartridge case . . . . .	1.45 pounds
Muzzle velocity:	
18-pound projectile . . . . .	550-700 feet per second
Maximum chamber pressure . . . . .	18,000 pounds per square inch
Maximum range . . . . .	4,142 yards
Minimum range . . . . .	1,975 yards

INTRODUCTION

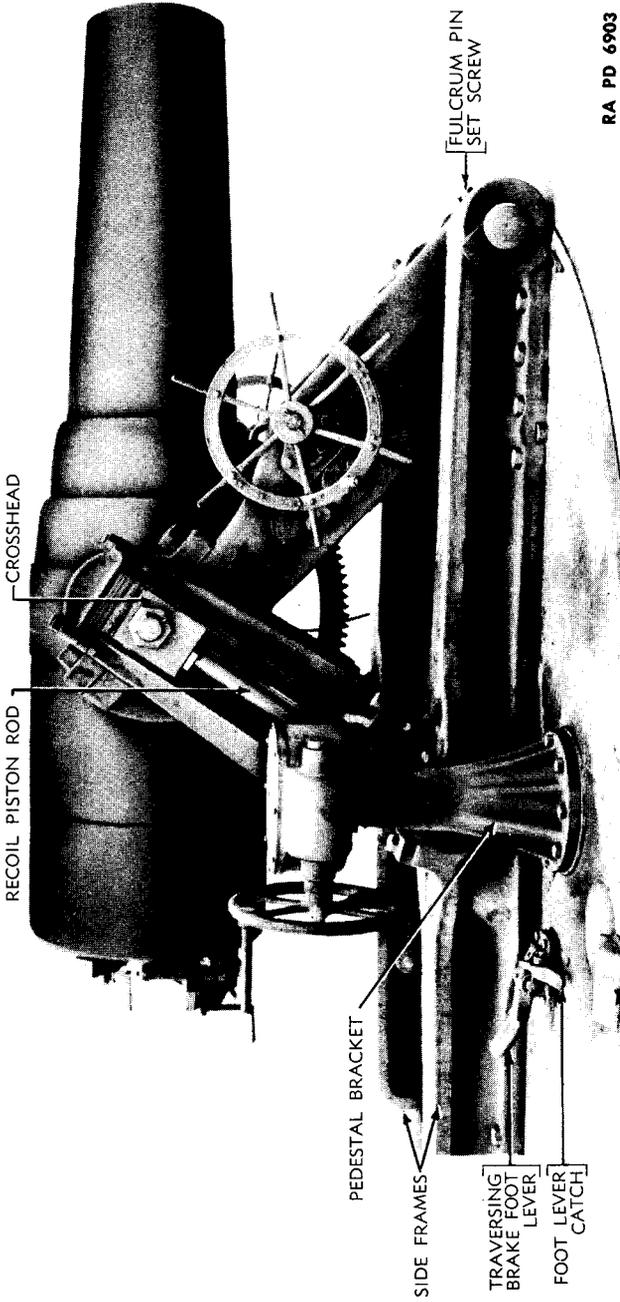

Figure 1 — Right Side View

12-INCH SEACOAST MATERIEL

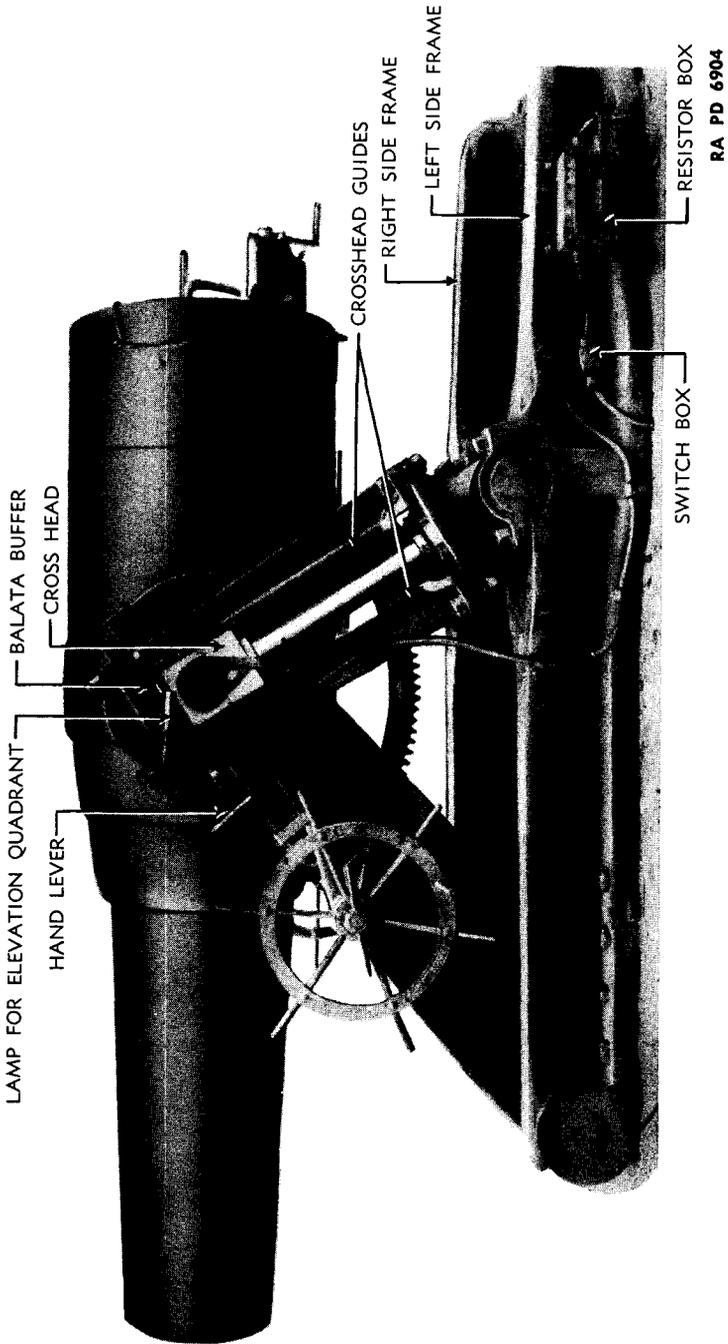
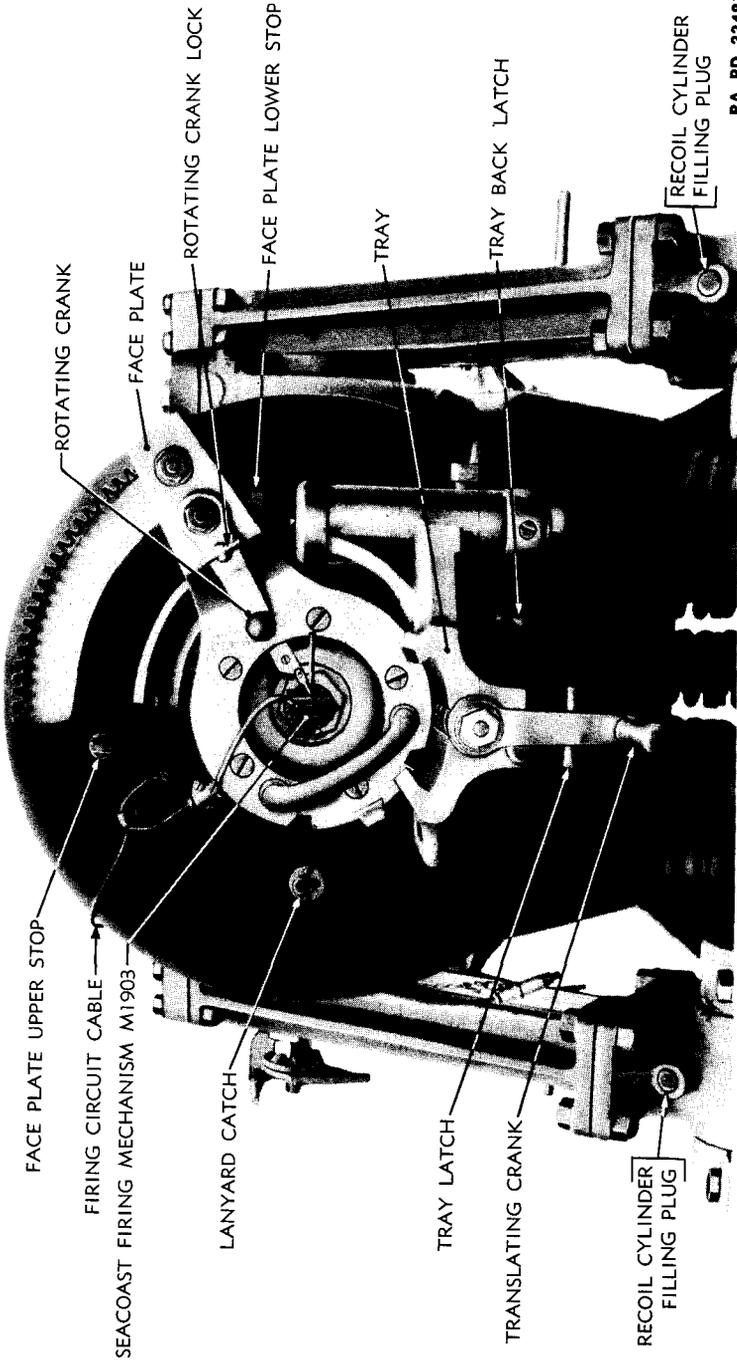

Figure 2—Left Side View

INTRODUCTION



RA PD 33481

Figure 3 — Rear View — Breech Closed

12-INCH SEACOAST MATERIEL

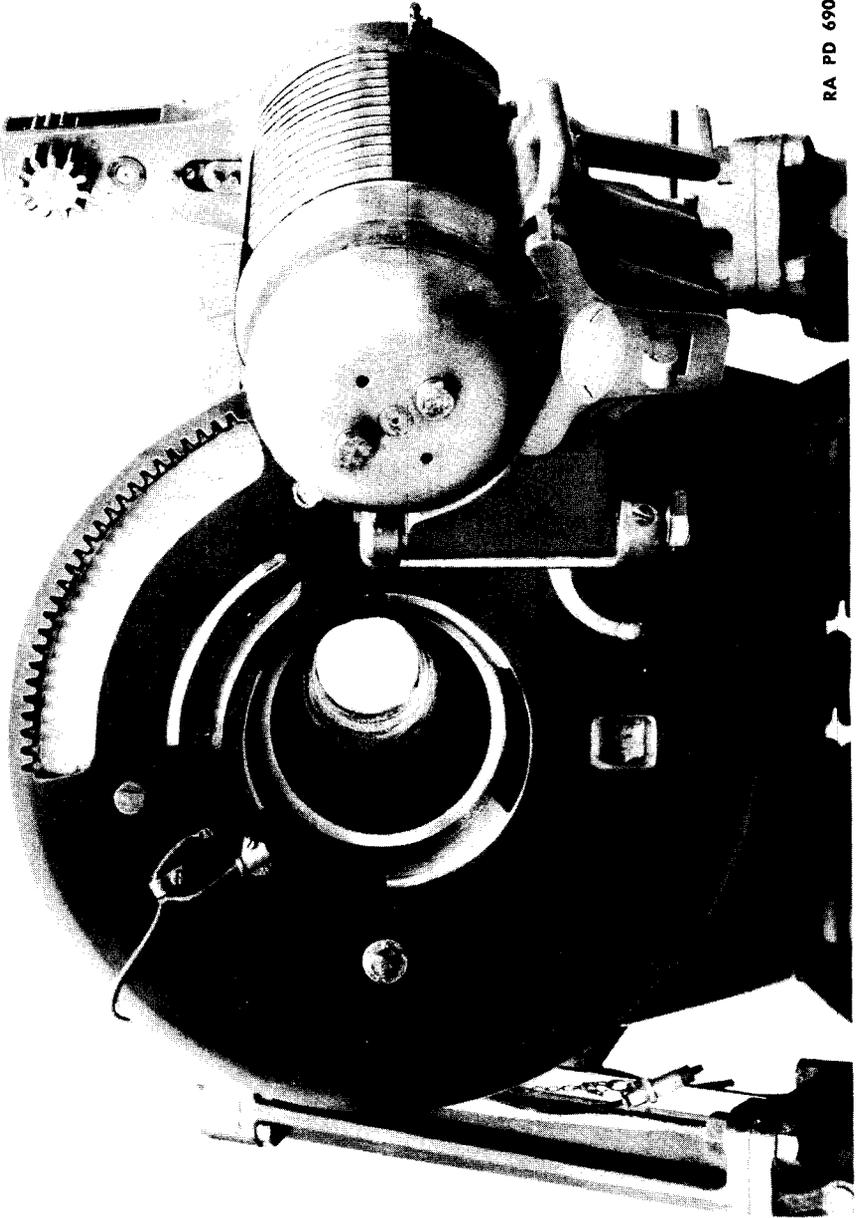

RA PD 6906

Figure 4—Rear View—Breech Open



12-INCH SEACOAST MATERIEL

Section II

DESCRIPTION OF MORTAR

	Paragraph
12-inch mortar M1890MI .....	4
Breech mechanism .....	5
Firing mechanism .....	6

4. 12-INCH MORTAR M1890MI.

a. This mortar is of the built-up type. The jacket fits over the rear end of the tube and projects beyond it. The breech bushing is screwed into the end of the jacket, and the breech mechanism is assembled into the recess in the breech bushing. The breech bushing bears interrupted threads for the matching threads of the breechblock.

5. BREECH MECHANISM.

a. **General.** The function of the breech mechanism is to close the breech and prevent the escape of burning gases. The breechblock is the main part of the mechanism. The breech mechanism is hinged so that it can be swung open for loading. It is operated by a rotating crank and a translating roller. The rotating crank rotates the breechblock by means of a gear and a rack cut in the surface of the breech face. The translating roller translates the breechblock by means of the helical grooves cut in the roller and a translating stud attached to the face plate on the breechblock. The tray supports the breechblock and pivots about the hinge pin to swing the breechblock clear of the breech recess.

b. **Principal Parts.** The breech mechanism consists of several related mechanisms, mainly: locking mechanism, rotating mechanism, translating mechanism, obturator mechanism and the tray mechanism. The term breech mechanism includes many additional related components, such as gears, pinions, blocks, latches, etc., that are necessary to facilitate its operation and function. The major detailed parts are as follows (figs. 3, 4 and 5):

(1) **BREECHBLOCK.** The breechblock is divided into six sectors, three threaded and three slotted. These are alternately arranged around the breechblock (fig. 5).

(2) **FACEPLATE.** The faceplate, shaped in the form of a banjo, and sometimes so called for that reason, is dovetailed into the face of the breechblock. This faceplate houses the gears and pinion. The rotating crank lock is used to lock the rotating crank which is used for rotating the breechblock. At the bottom of the faceplate, a large handle is pro-

### DESCRIPTION OF MORTAR

vided for use when pulling the breechblock out of the breech into the tray for disassembling purposes (fig. 5).

(3) **THE OBTURATOR.** The obturator does not rotate with the breechblock during opening or closing the breech. The breechblock rotates about the spindle of the obturator as an axle. When the weapon is fired, the obturator is forced to the rear, compressing the plastic gas-check pad and split rings and expanding them radially making them gas-tight sealed. After firing, the pressure is removed and the obturator returns to normal position.

(4) **TRAY.** The tray is suspended on the upper surface of the lower hinge lug and is held in position by the hinge pin. The contour of the tray fits a corresponding contour in the lower part of the breechblock.

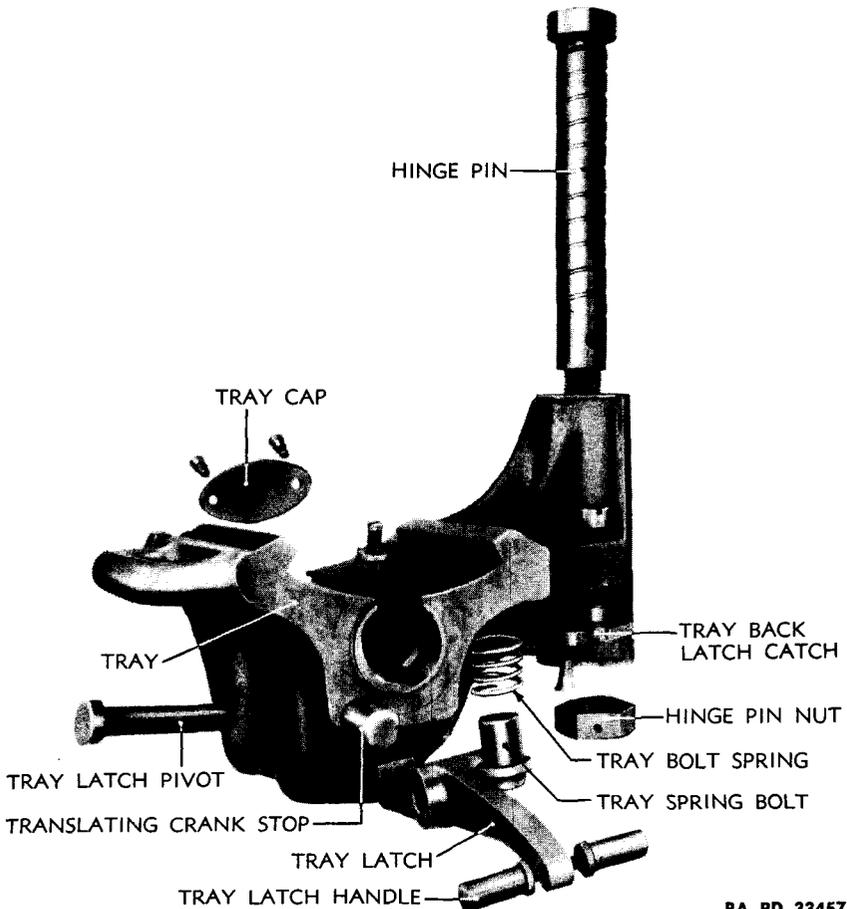

**Figure 6—Tray—Exploded View**

RA PD 33457

**12-INCH SEACOAST MATERIEL**

When in closed position, the tray is held to the breech face of the mortar by means of a tray latch, which fits in the tray latch catch (figs. 3, 4 and 6).

(5) **TRAY HINGE.** The tray hinge is secured to the breech face of the mortar by screws. It is set into the mortar jacket and breech bushing flush with the breech face, preventing the bushing from rotating in the jacket. There are two lugs on the hinge for the hinge pin (fig. 3).

(6) **HINGE PIN.** The hinge pin passes through the lugs of the tray hinge and is held in place by a nut on the lower end. The tray is free to revolve about the pin. There are grooves on the hinge pin for lubrication purposes (fig. 3).

(7) **ROTATING CRANK.** The rotating crank is used to rotate the breechblock within the breech recess in order to engage or to disengage threads of the breechblock from the matching threads of the breech recess (fig. 3).

(8) **ROTATING GEAR.** Power to rotate the breechblock is furnished through the rotating gear by means of a rotating crank (fig. 5).

(9) **TRANSLATING ROLLER.** After the breechblock is rotated within the breech recess so that the threads are disengaged, the block is brought directly to the rear by means of the translating crank as the translating stud is engaged on the translating roller (fig. 3).

(10) **TRAY LATCH.** The tray latch latches the tray in the tray latch catch when the breech mechanism is in the closed position (figs. 3 and 6).

(11) **TRAY BACK LATCH.** The tray back latch latches the breechblock and tray in the tray back latch catch when the breech mechanism is in full open position (figs. 6 and 30).

(12) **TRAY SPRING BOLT.** The tray spring bolt fits into a recess on the under side of the tray along with the tray bolt spring. The spring forces the bolt down on the tray latch, thus keeping the tray latch positively engaged with the tray latch catch. This tends to prevent accidental opening of the tray during firing (fig. 6).

**6. FIRING MECHANISM.****a. General.**

(1) Seacoast firing mechanism M1903 is attached to the rear end of the obturator spindle by means of a hinged collar. This mechanism is constructed to receive either an electric or a friction primer. When the slide is in its uppermost position, the primer is inserted in the vent in the obturator spindle, the head of the primer resting in its seat in the ejector. When the slide is pushed down, it passes over the primer wire and also encloses a button on the end of the wire (figs. 7, 8 and 9).

(2) A pull on the lanyard rotates the firing leaf about its axis, thereby drawing out the primer wire of friction primers. The closing of an electric

DESCRIPTION OF MORTAR

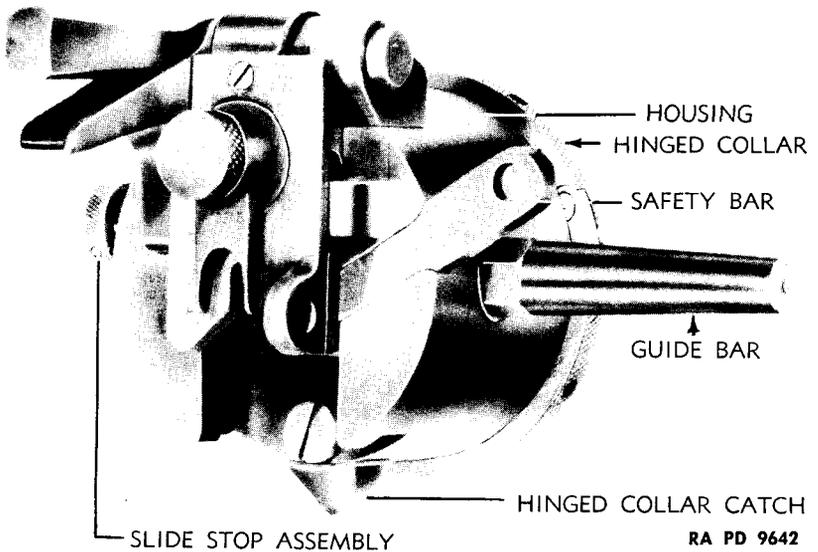
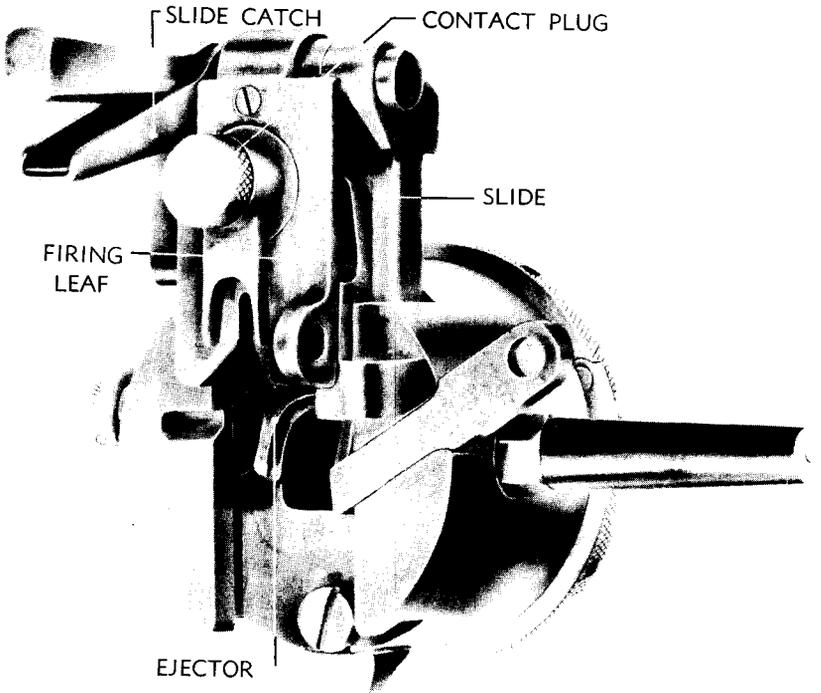

RA PD 9642

Figure 7—Seacoast Firing Mechanism M1903—Assembled View—Open and Closed Position

12-INCH SEACOAST MATERIEL

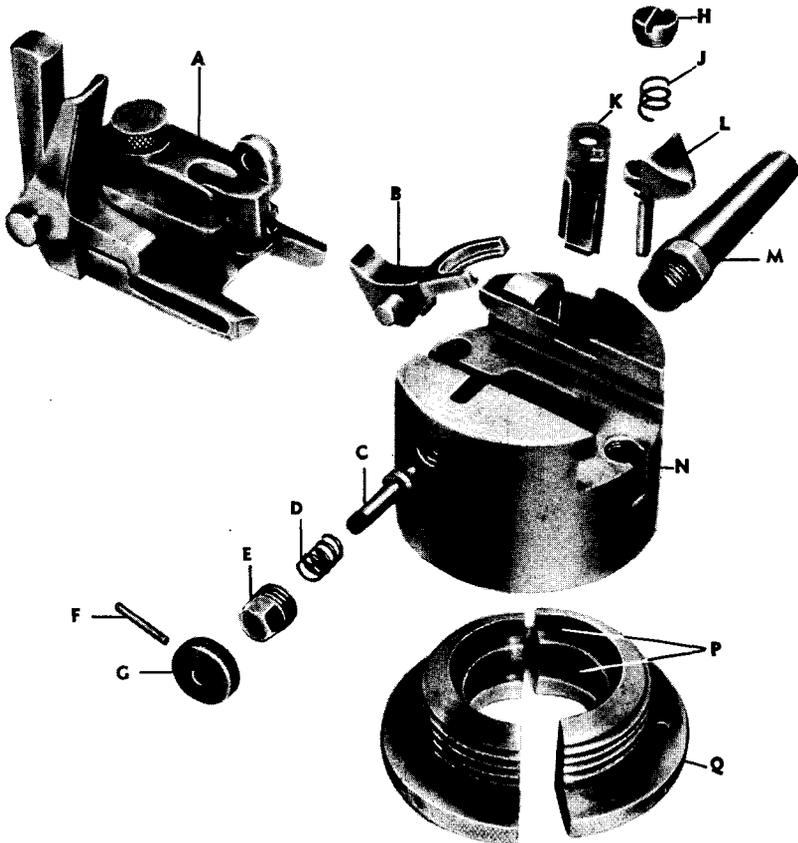

A — SEACOAST FIRING  
MECHANISM SLIDE

B — EJECTOR

C — SLIDE STOP BODY

D — SLIDE STOP SPRING

E — SLIDE STOP HOUSING

F — TAPER PIN

G — SLIDE STOP NUT

H — HINGED COLLAR  
CATCH SCREW

J — HINGED COLLAR  
CATCH SPRING

K — FIRING MECHANISM  
SAFETY BAR

L — HINGED COLLAR CATCH

M — GUIDE BAR

N — SEACOAST FIRING  
MECHANISM HOUSING

P — SEAT GROOVES

Q — HINGED COLLAR

RA PD 9643

**Figure 8—Seacoast Firing Mechanism M1903—Exploded  
View, Housing**

DESCRIPTION OF MORTAR

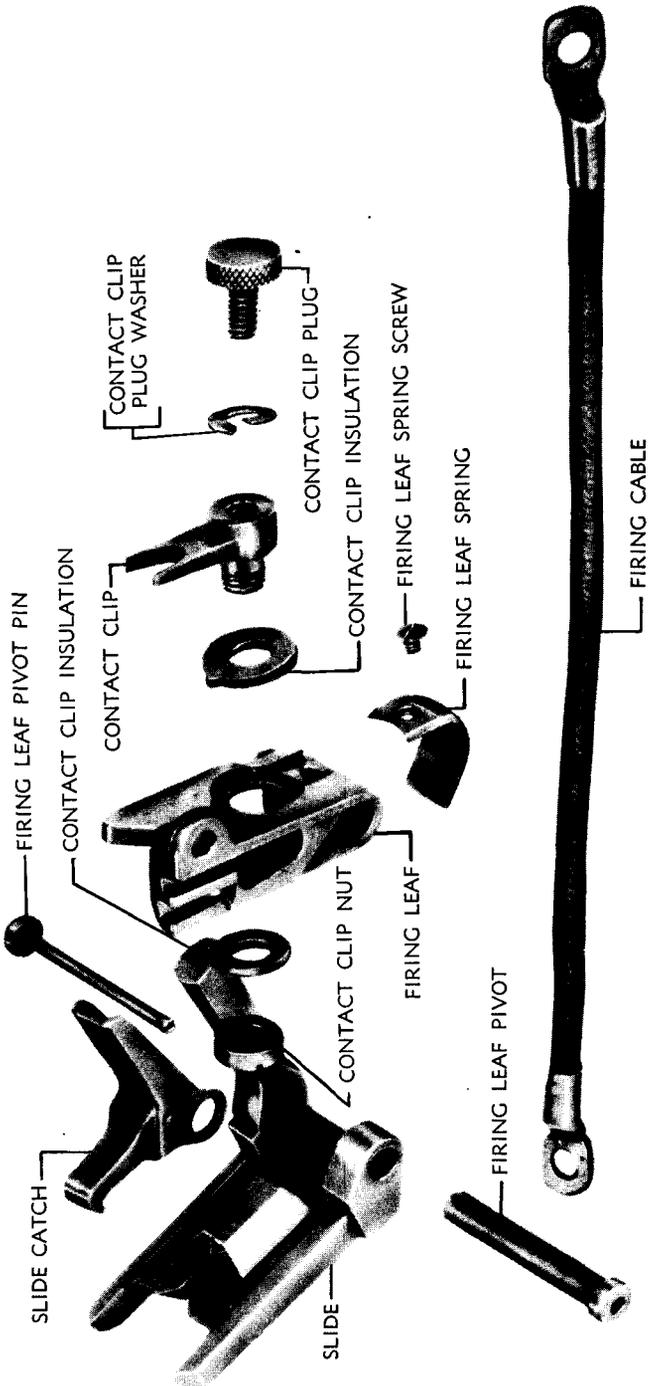

RA PD 9646

Figure 9—Seacoast Firing Mechanism M1903—Exploded View, Slide

**12-INCH SEACOAST MATERIEL**

circuit, which enters the mechanism through the electrical terminal, fires electric primers. A safety lug which engages in a groove in the firing leaf prevents the latter from being drawn to the rear before the slide is all the way down, or before the breechblock is locked in the closed position.

b. The principal parts of the firing mechanism are: hinged collar, housing, slide, firing leaf, safety bar, and ejector.

(1) **HINGED COLLAR AND HOUSING.** Two grooves on the inner surface of the hinged collar engage in corresponding ribs on the spindle. The housing is threaded to receive the hinged collar, and a spring catch locks the collar to the housing when it is fully screwed home. The collar is thus prevented from opening and secures the housing to the spindle.

(2) **GUIDE BAR.** A guide bar projects from the right side of the housing into a groove cut in the breechblock recess and causes the housing to rotate with the breechblock.

(3) **SLIDE.** The slide travels vertically in grooves cut in the rear face of the housing. When in its lowest position, it covers the primer and engages the primer wire. Its motion is limited by the slide stop on the left side of the housing. The slide catch serves to lock it in place when lowered, and to support it at the proper height to allow the primer to be inserted when raised.

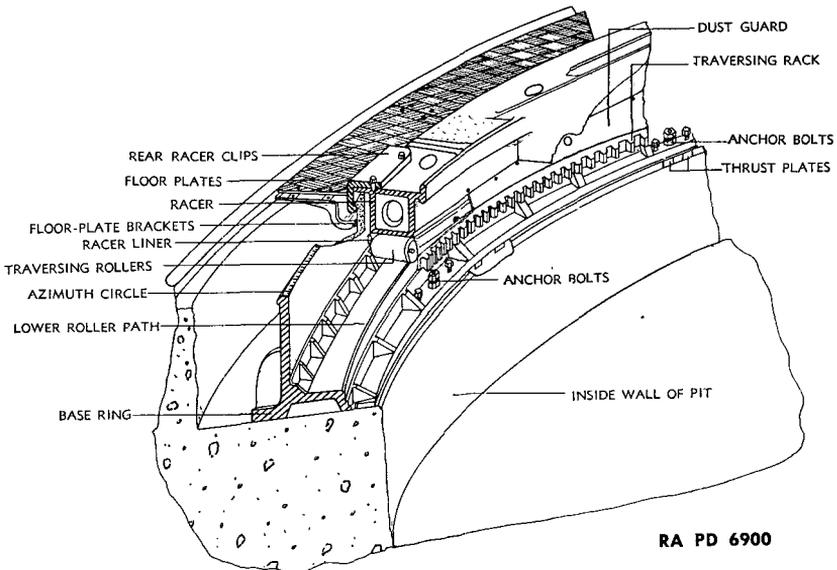

RA PD 6900

**Figure 10—Base Ring and Racer Assembly**

## DESCRIPTION OF MORTAR

(4) **EJECTOR.** The ejector is an irregular shaped piece with trunnions on each side which enter two slots in the housing. The lower arm of this ejector is fork-shaped and hangs over the mouth of the primer seat under the head of the primer. The horizontal arm projects to the rear into a recess in the slide. When the latter is lifted, this arm is carried upward and the ejector rotated about its trunnions so as to throw the lower arm to the rear, ejecting the primer.

(5) **FIRING LEAF.** The firing leaf is pivoted to the slide at its upper end. It has a vertical slot cut in its lower edge through which the wire of the primer projects when the slide is in its lower or locked position. At the right-hand lower corner of the leaf is an eye into which the lanyard is hooked for friction firing. When the leaf is drawn to the rear, it engages the button on the end of the primer wire, draws the wire out, and fires the primer by means of friction.

(6) **CONTACT CLIP.** Electric connection with the primer is made through the arms of the contact clip, which encloses the button of the primer. The firing cable connects to the contact clip on the rear face of the leaf. The other end assembles the circuit breaker contact.

## (7) SAFETY BAR.

(a) The safety bar prevents accidental firing of the piece by the lanyard before the breech is fully closed, and a circuit breaker prevents accidental firing by electricity. The first motion of rotation of the breech-block forces the safety bar inward so as to engage the leaf and prevent

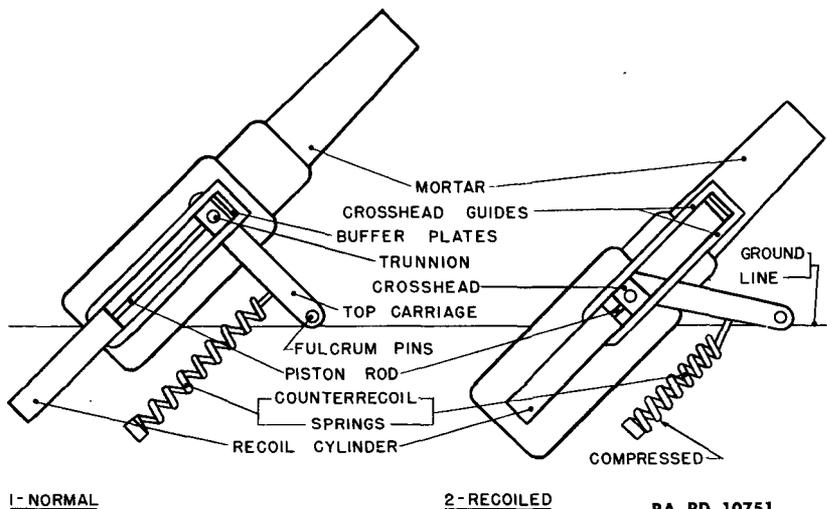

**12-INCH SEACOAST MATERIEL**

its being drawn to the rear, while at the same time the electric circuit is broken by the same movement of rotation.

(b) The safety bar is attached to the end of the safety bar slide, and the safety bar slide is operated by a cam surface in the breech bushing.

(c) The safety bar slide latch is secured to the face of the breechblock by two screws. A projection on its outer end overhangs the outer end of the safety bar slide, preventing the slide from being raised before the breechblock is closed.

(d) As the breechblock is rotated to closed position, the projection of the slide latch slides on a cam surface which raises the latch a sufficient amount to clear the end of the safety bar slide. The safety bar slide cam then follows its cam surface until the safety bar disengages from the firing leaf. The operation of this is the same for all mortars in service.

(8) **CIRCUIT BREAKER.** The bronze circuit breaker consists of two principal pieces which are brought together when the breechblock is rotated to its locked position. A plunger, working under the pressure of a spring, serves to make electric contact between the two pieces. Since the piece is used as an electrical ground, both parts of the circuit breaker must be insulated from the mortar.

Section III

**DESCRIPTION OF CARRIAGE**

	Paragraph
General .....	7
Recoil mechanism .....	8
Counterrecoil mechanism .....	9
Elevating mechanism .....	10
Traversing mechanism .....	11
Azimuth circle and pointer .....	12
Lanyard attachment .....	13
Electrical equipment .....	14

**7. GENERAL.**

a. The mortar carriage consists of a base ring bolted rigidly to the concrete emplacement and of a mortar-supporting structure which rests on the base ring and is capable of moving in azimuth upon it. The base of the carriage consists of the base ring, traversing rollers, and racer. The top surface of the base ring forms the lower roller path for the traversing rollers, and the lower surface of the racer forms the upper roller path. The racer is the principal part of the base since it carries all the moving parts of the carriage except the traversing roller system. On the upper surface of the racer are two large side frames in which the top carriage is mounted and which provides bearings for the trunnions of the recoil cylinders (fig. 10).

b. The upper portion of the carriage consists of the top carriage, recoil mechanism, counterrecoil mechanism, elevating mechanism, traversing mechanism, elevation quadrant, lanyard attachment, and electrical equipment.

c. The top carriage mounts the mortar on the racer structure. The lower end of the top carriage is held to the racer by fulcrum pins so that during recoil and counterrecoil the top carriage will pivot. Recoil cylinders are provided to check the recoil of the mortar, and counterrecoil springs to return the mortar to battery (fig. 11). An elevating lock holds the mortar horizontal while loading, an elevation clamp holds the piece at the desired elevation, and a traversing brake holds the piece at the proper azimuth.

**8. RECOIL MECHANISM.**

a. The recoil of the piece is checked by means of two hydraulic cylinders and by the resistance from the compression of the counterrecoil springs. The recoil cylinders are attached to the racer between the side frame ribs by trunnions on the cylinder. When assembled, the lower ends

**12-INCH SEACOAST MATERIEL**

of these cylinders extend through the racer. Each cylinder is fitted with a piston rod which works through stuffing boxes in both ends of the cylinder. Each stuffing box contains hydraulic packing which is held in place by a gland and follower. The seats for the packing in the cylinders

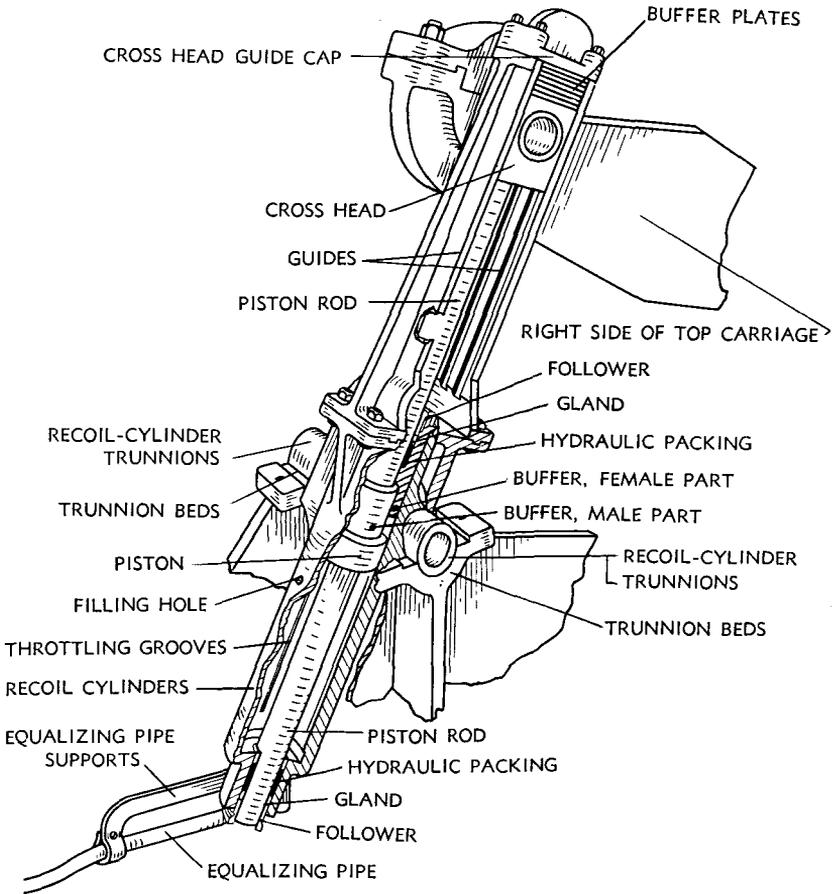

RA PD 6902

**Figure 12—Recoil Mechanism Assembly**

and also the glands are beveled slightly, so that when the follower is screwed against the gland, the packing is pressed firmly against the outside surface of the piston rod. This prevents the oil from escaping when the mortar recoils or counterrecoils. The upper ends of the piston rods terminate in crossheads, through which the crank pins act to move the

**DESCRIPTION OF CARRIAGE**

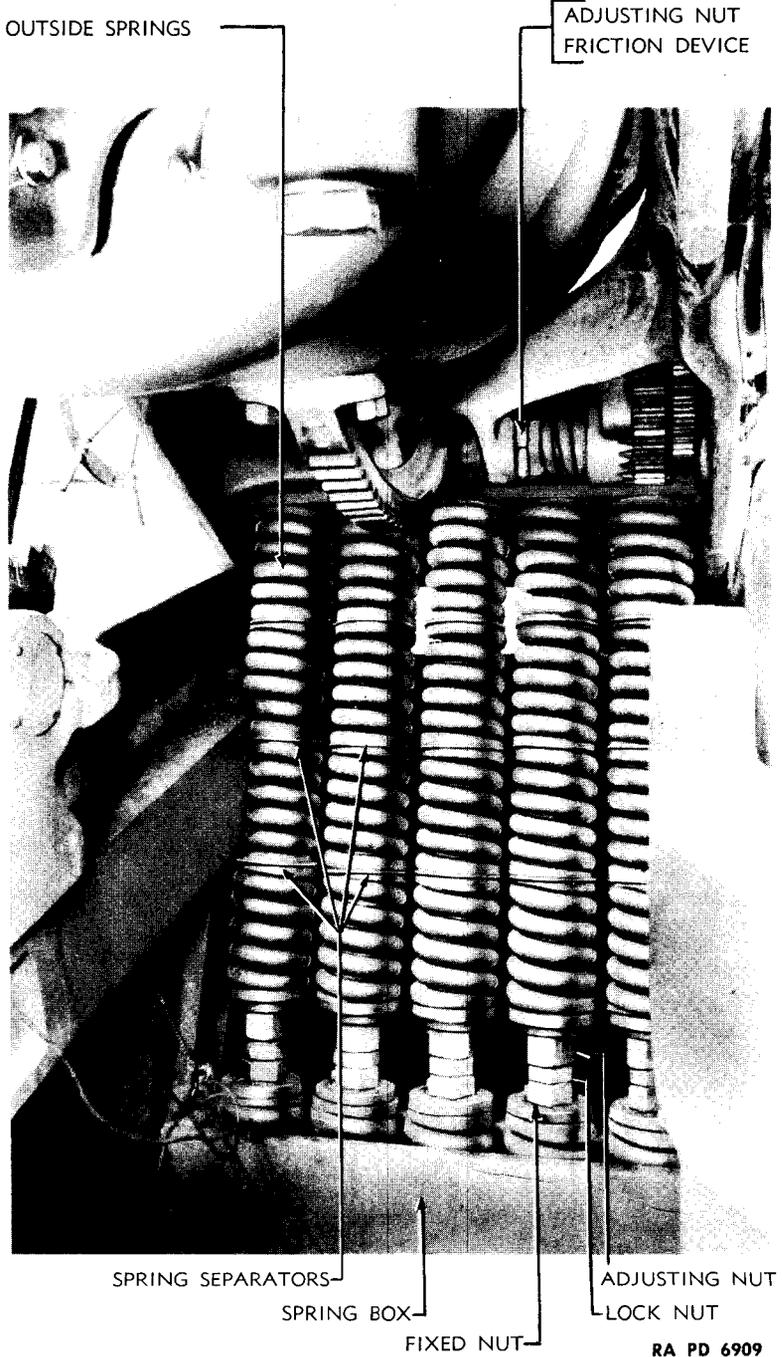

**Figure 13—Counterrecoil Springs**

**12-INCH SEACOAST MATERIEL**

piston rods. The crank pins are extensions of the trunnions which pivot in the upper ends of the top carriage sidearms (fig. 12).

b. When the mortar recoils, the pistons move down, oil moving past the piston through the throttling grooves. Near the end of the piston stroke, the throttling grooves become shallower; and at the end of the stroke, they taper to nothing. The oil pressure on the lower side of the pistons gradually transfers the force of the recoiling parts to the recoil cylinder and thus to the racer. The purpose of the oil in the cylinders is to prevent a shock to the carriage both during recoil and during counterrecoil. The resistance which the oil offers to the movement of the pistons through the cylinders during recoil takes up that part of the energy of recoil not absorbed by the counterrecoil springs.

**c. Counterrecoil Buffers.**

(1) To prevent the shock to the carriage by reason of the sudden expansion of the springs returning the mortar to battery, a buffer is included in each cylinder. This consists of a recess cut in the lower part of the cylinder head, called the female part of the buffer, and a corresponding projection on the piston rod, called the male part of the buffer. During counterrecoil, the piston in moving upward forces the oil into the recess in the cylinder head; and when the projection on the piston rod reaches the recess, it can only enter by forcing oil out of the recess through the clearance between the walls of the male and female parts of the buffer. The oil left in the recess acts as a cushion, gradually checking the return of the piece into battery.

(2) Buffer plates between the crosshead guide cap and the upper end of the crosshead serve as an additional precaution against shock when the mortar is returning to firing position.

d. **Equalizing Pipe.** The lower ends of the hydraulic cylinders are connected by an equalizing pipe. This equalizes the quantity of oil in each cylinder, so that when the mortar is fired there will be equal pressure and equal resistance in both cylinders. The emptying coupling, located in the equalizing pipe line, is for draining the recoil oil (fig. 12).

**9. COUNTERRECOIL MECHANISM.**

a. The upper end of the top carriage moves downward during recoil of the mortar. This movement compresses the counterrecoil springs which return the top carriage and mortar to firing position after the recoil is completed (fig. 13).

b. The top carriage is supported at a point about one-third its length from the lower end by five columns of springs. Each column consists of five outer springs and five inner springs mounted on the spring guide rods. These rods serve to hold the springs in position during recoil or counterrecoil.

DESCRIPTION OF CARRIAGE

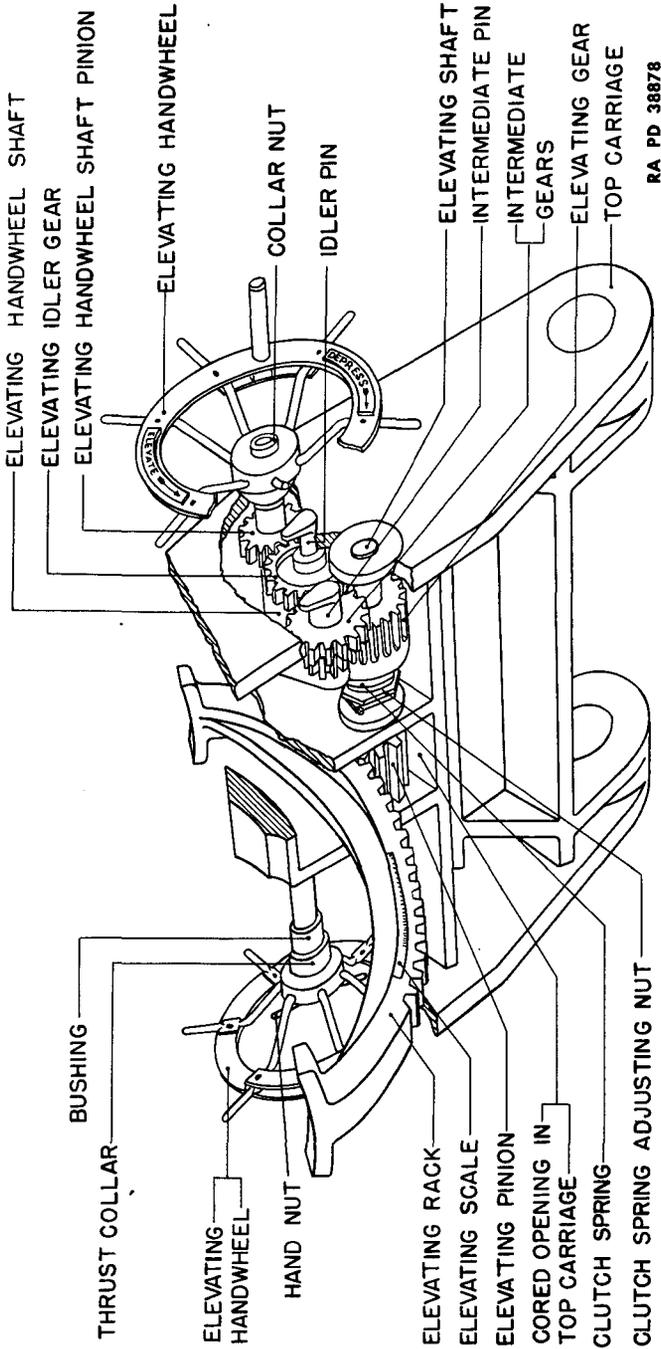

RA PD 38878

Figure 14—Elevating System

12-INCH SEACOAST MATERIEL

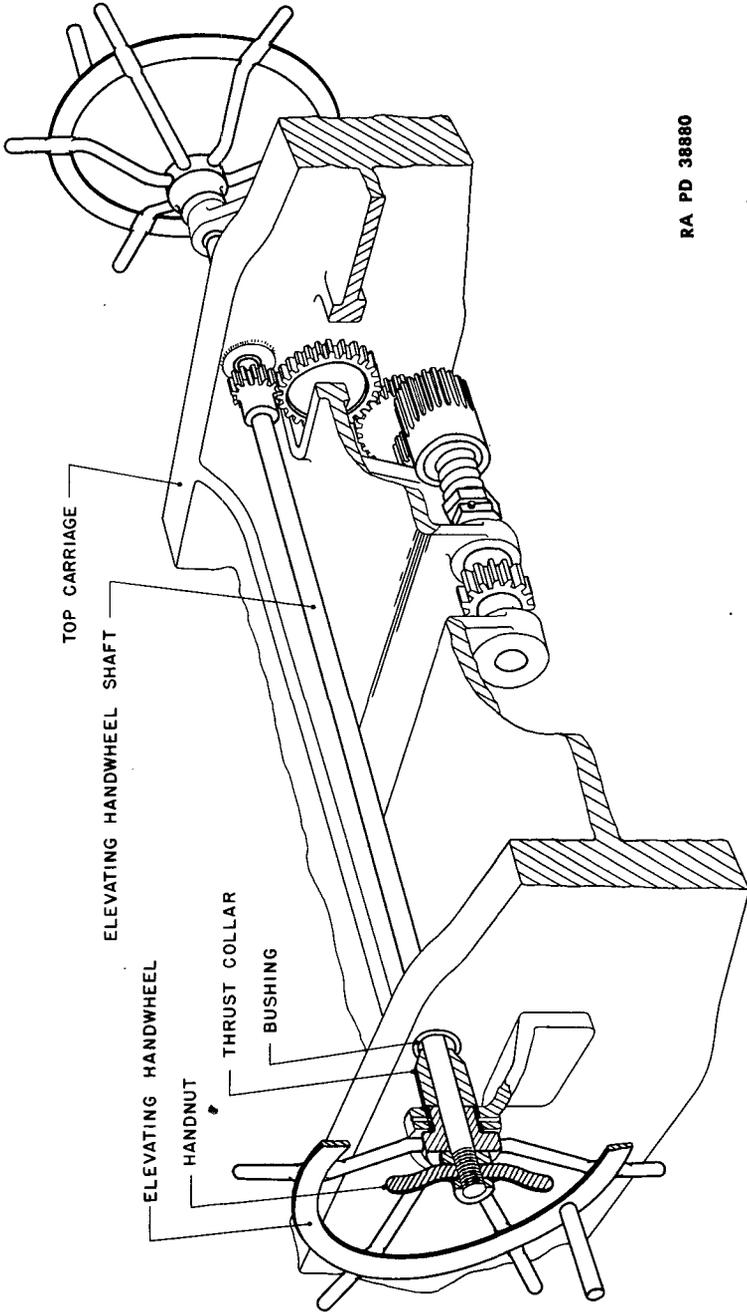

RA PD 38880

Figure 15—Elevating Locking Device

DESCRIPTION OF CARRIAGE

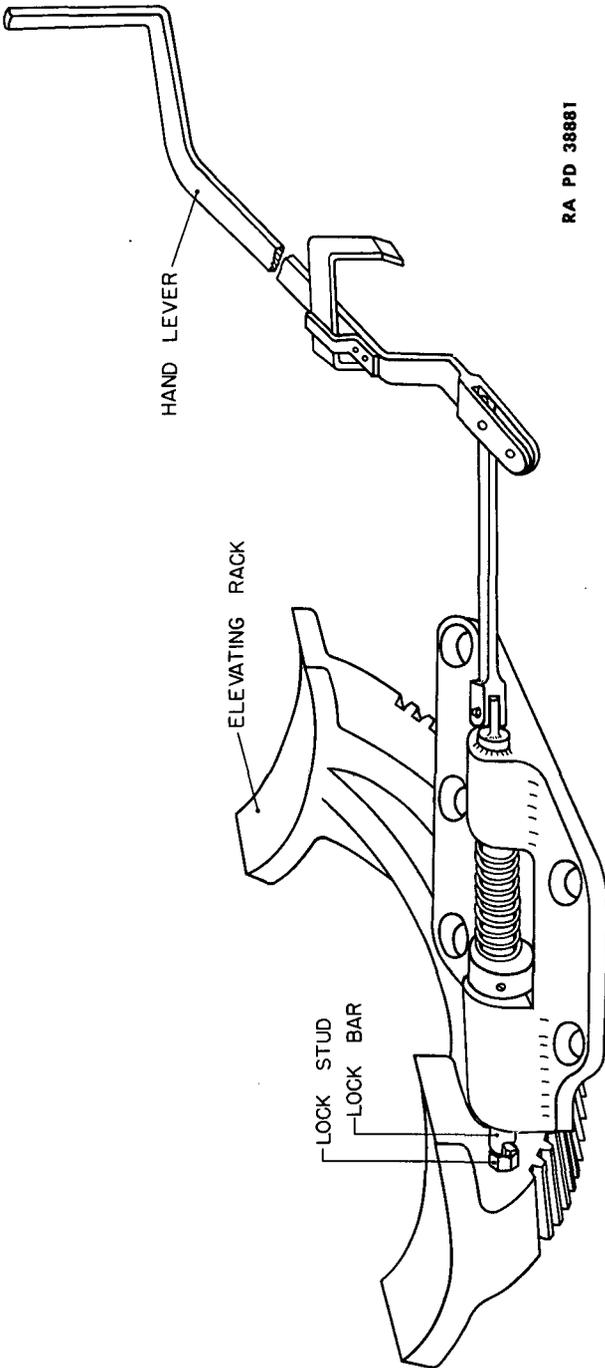

RA PD 38881

Figure 16 — Elevating Lock

**12-INCH SEACOAST MATERIEL**

c. The lower ends of the spring columns rest in a spring box and the upper ends bear against the spring cap underneath the top carriage. The spring box is hung by trunnions in two brackets which are bolted to the under side of the racer. This arrangement permits the spring box to tip either backward or forward as the position of the spring columns changes due to the recoil or counterrecoil of the piece. The spring cap performs the same function above as the spring box does below. This cap is made with a knife edge bearing. During recoil and counterrecoil, this bearing rocks in a groove running across the lower surface of the top carriage. The spring box, spring cap, and top carriage are each provided with holes through which the ends of the spring rods pass freely.

**10. ELEVATING MECHANISM.**

a. The purpose of the elevating system is to elevate the mortar for firing and, after firing, to depress it to a horizontal position for loading. To accomplish this, a circular elevating rack is bolted to the under part of the mortar. This rack is provided with teeth which engage in a pinion fastened to a heavy elevating shaft, located on the under surface of the top carriage. The elevating shaft is connected through a series of gears to the elevating handwheel shaft. This shaft is provided with a handwheel at each end by means of which the mortar is elevated and depressed (fig. 14).

b. When the mortar is elevated to the desired firing angle, it is held in place by means of a hand nut on the left elevating handwheel. The nut locks the shaft in position by pressing a thrust collar against a bushing located in the web of the top carriage. The hand nut is provided with handles to facilitate locking the shaft in position (fig. 15).

c. To hold the mortar in a horizontal position for loading and to insure against accidental elevation of the mortar when the breechblock is thrown open, an elevation locking device is provided on the left side of the top carriage. A lock stud is screwed in place in the elevating rack. When the mortar is depressed to zero degrees, the lock stud automatically engages with a lock bar. When in locked position, the elevation lock is released by means of a hand lever. The hand lever disengages the spring-actuated lock bar from contact with the lock stud (fig. 16).

d. On each side of the elevating rack, there is an elevation scale graduated in degrees. A scale pointer is attached to the top carriage on each side.

e. The elevation mechanism is provided with a friction device to prevent injury to the teeth of the elevating gearing which might be caused by the shock of recoil or by bringing the mortar against the depression or elevating stops with too great a force. This device consists of alternate bronze and cast-iron disks which are assembled in a recess in the elevating gear. The bronze disks are keyed to the elevating gear and rotate with it while the cast-iron disks are keyed to the elevating shaft, along with the

## DESCRIPTION OF CARRIAGE

elevating gear plate. The disks fit loosely on the keys and are forced tightly against each other and the inner face of the elevating pinion in such a manner as to create sufficient friction to prevent the elevating gear from slipping on the elevating shaft.

To hold the disks in proper contact, a spring, held by a nut, bears against the elevating gear plate forcing the disks tightly together (fig. 17).

### 11. TRAVERSING MECHANISM.

a. The traversing mechanism consists of the circular traversing rack attached to the inside of the base ring and the vertical traversing shaft through the racer. The horizontal worm on the traversing handwheel shaft meshes with the worm wheel on the upper end of the traversing shaft. The traversing pinion on the lower end of the traversing shaft meshes with the traversing rack on the racer. The worm, worm shaft, worm wheel, and the part of the vertical shaft above the racer are incased in a pedestal which has oil and drain holes so arranged that the worm and the rim of the worm wheel run in oil (fig. 18).

b. A traversing brake is provided to maintain the piece in azimuth without further movement, until the mortar has been fired. It consists of a toggle and coiled spring acting to cause a brake shoe to bear on the traversing rack. The brake is operated from the top side of the racer near the azimuth pointer by two pedals. One pedal acts as a foot lever, the other as a catch. Depressing the foot lever sufficiently to engage the catch raises the brake shoe from the brake path on the traversing rack and permits free motion of the racer. Releasing the foot lever by depressing the catch throws the brake on (fig. 21).

### 12. AZIMUTH CIRCLE AND POINTER.

a. The azimuth circle consists of a flat brass ring fastened to the vertical flange of the base ring. It is graduated in degrees and numbered at each graduation. The azimuth pointer or subscale, fastened to the racer, is subdivided into 0.05 degrees and stamped in hundredths of one degree. The azimuth pointer is visible through a hole in the racer near the traversing pedestal, enabling the operator of the traversing wheel to stop at any desired point on the azimuth circle. An electric light is provided for illuminating the scale and pointer. A cover and shield are provided to protect the lamp and pointer from damage when not being used (fig. 20).

### 13. LANYARD ATTACHMENT.

a. The lanyard, used to fire when a friction primer is employed, consists of a short Manila rope which passes down through a hole in the racer at the rear of the central opening on the right-hand side. It passes beneath the racer through the lanyard pulley and up through the racer on the left-hand side, and terminates in the button. The lanyard passes up through the right-hand hole in the racer through the safety lanyard device to the firing mechanism on the breach of the mortar (fig. 19).

12-INCH SEACOAST MATERIEL

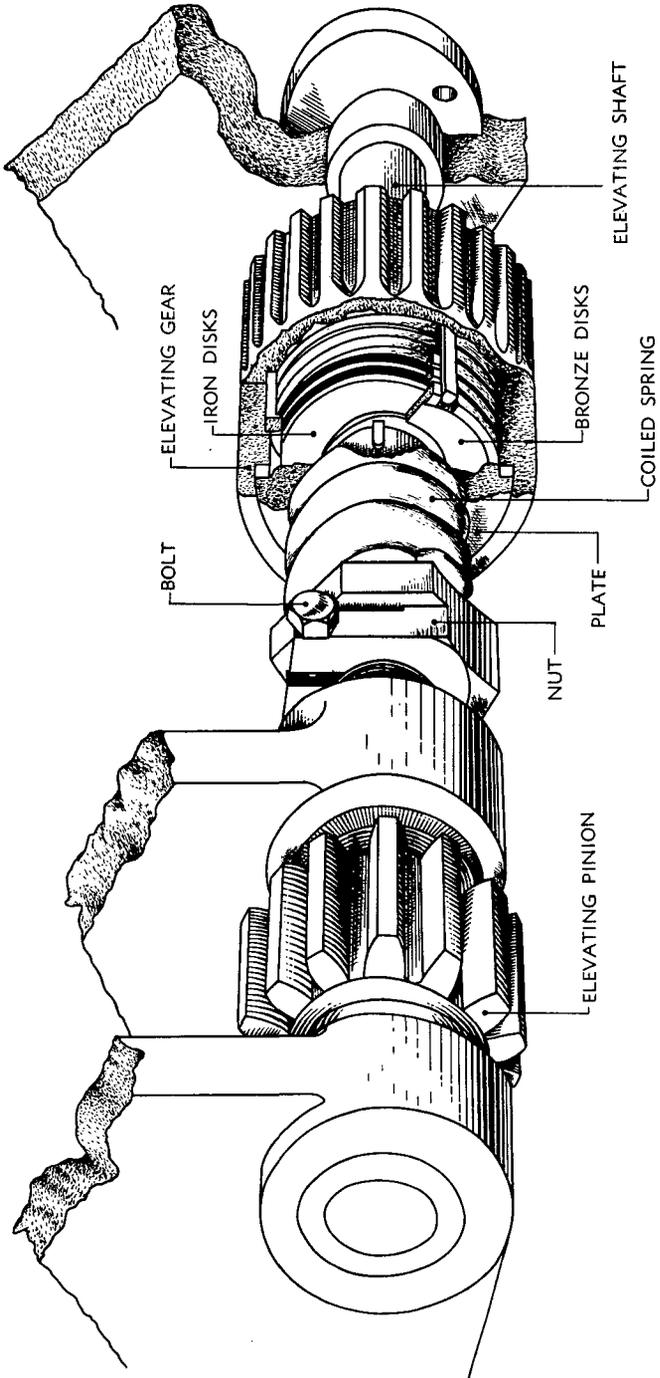

RA PD 6891

Figure 17—Elevating Friction Device

DESCRIPTION OF CARRIAGE

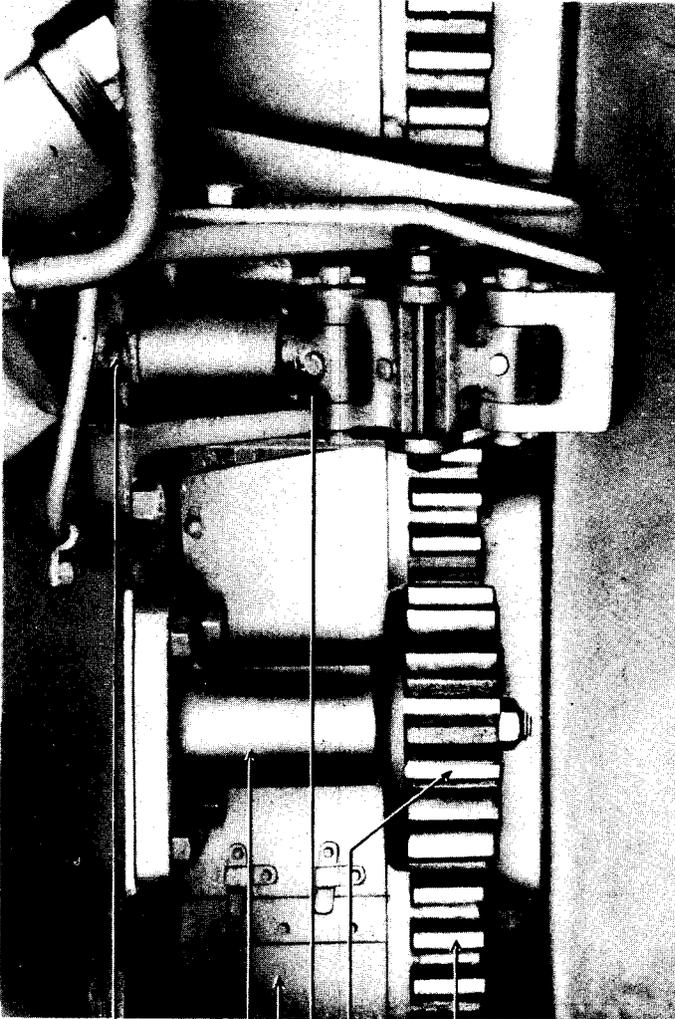

RA PD 6908

ADJUSTING NUT

VERTICAL SHAFT BRACKET

DUST GUARD

BRAKE ASSEMBLY

TRAVERSING PINION

TRAVERSING RACK

Figure 18—Traversing Pinion and Brake

12-INCH SEACOAST MATERIEL

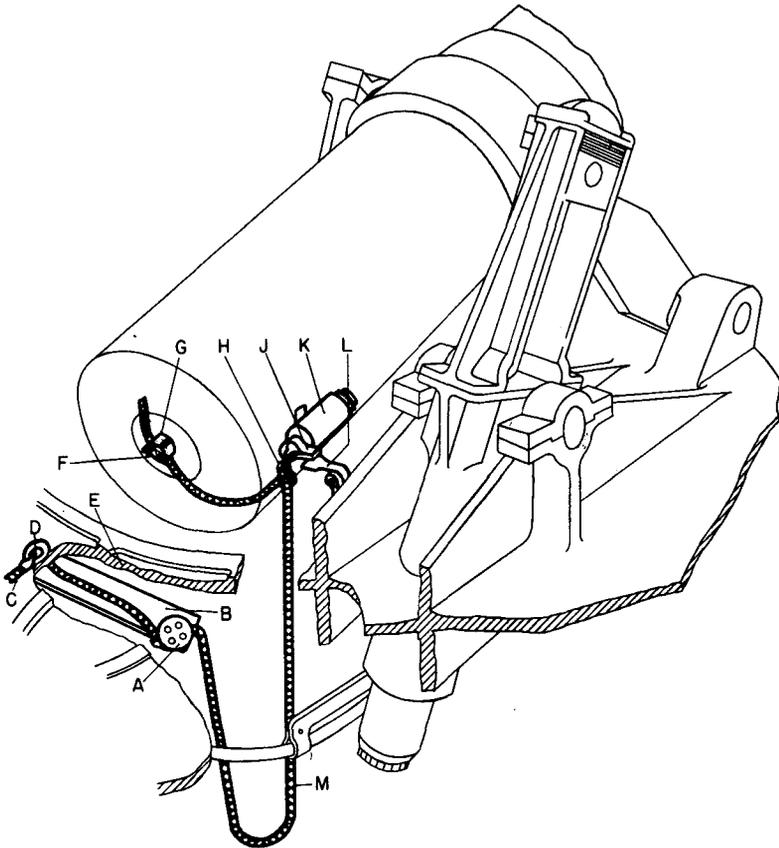

- |                  |                    |                     |
|------------------|--------------------|---------------------|
| A-LANYARD PULLEY | E-HOLE IN RACER    | J-BRIDLE RING CATCH |
| B-PULLEY BRACKET | F-LANYARD HOOK     | K-LANYARD HOUSING   |
| C-LONG LANYARD   | G-FIRING MECHANISM | L-HINGED DOG        |
| D-LANYARD BUTTON | H-BRIDLE RING      | M-SHORT LANYARD     |

RA PD 6897

**Figure 19—Lanyard Safety Device Assembly**

b. The lanyard safety device prevents accidental firing of the mortar by the lanyard before the minimum firing elevation has been reached. When the safety device is engaged, a pull on the lanyard does not reach the firing mechanism but is arrested by the safety device. After the mortar reaches the minimum elevation, the safety device is automatically released, and any pull on the lanyard can then be transmitted directly to the firing mechanism. The safety device, located at the right side of the breech, consists of a hinged dog and a bridling ring catch. The bridling ring on

### DESCRIPTION OF CARRIAGE

the lanyard is secured to the bridle ring catch, and the hook of the lanyard is attached to the firing mechanism. When the mortar is elevated to the minimum firing angle, the safety device automatically opens, releasing the lanyard from the bridle ring catch. Because of the hinge feature of the dog, the mortar can be returned to loading position without interference with the bridle ring catch.

#### 14. ELECTRICAL EQUIPMENT.

a. The electrical equipment on these carriages consists of the lighting and firing circuits (fig. 20).

(1) **LIGHTING CIRCUIT.** Power for the lighting circuit is supplied from the mains of the emplacement through the lighting circuit receptacle box. This receptacle box is bolted to the under side of the base ring. Cables connect the receptacle box to the junction box, and the junction box to the following outlets: the azimuth lamp, the quadrant lamp, and the plug box. This plug box is used as a connection for a portable lamp. The circuit from the junction box to the two lamps leads through the lighting switch and resistance box. The resistance box furnishes the means of reducing the 110 or 220 volts of the power main to the 16 volts required at the lamp terminals.

(2) **FIRING CIRCUIT.** Power for the firing circuit is supplied to the watertight firing circuit receptacle box. This power is brought through a hand-operated magneto attached to a bracket on the wall of the emplacement. A cable from the magneto furnishes power to the firing mechanism and the primer. One side of this circuit is grounded to the mortar; the other side is insulated from the mortar and connected to the firing mechanism. The firing circuit is closed by the electric primer, which is fired when current passes between the insulated cable to the grounded mortar.

12-INCH SEACOAST MATERIEL

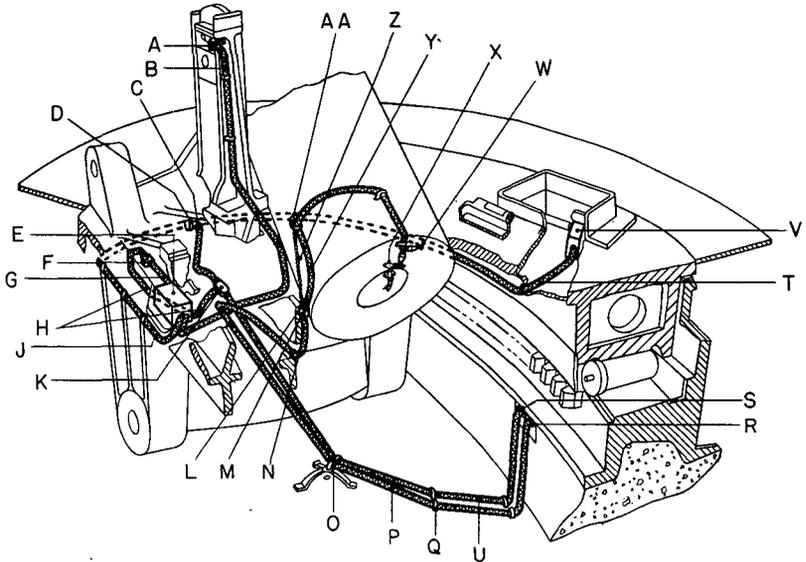

- A - QUADRANT LAMP BRACKET
- B - CABLE TO QUADRANT LAMP
- C - CIRCUIT FOR PORTABLE LAMP
- D - ENGINEER'S PLUG BOX
- E - RESISTANCE BOX
- F - WATER TIGHT SWITCH
- G - CABLE TO RESISTANCE
- H { CIRCUIT FOR AZIMUTH  
AND QUADRANT LAMP
- J - CABLE TO QUADRANT LAMP
- K - JUNCTION BOX
- L - SAFTY FIRING PLUG
- M - RECEPTACLE BOX ( FIRING PLUG)
- N - FIRING CIRCUIT CABLE
- O - DOUBLE PULLEY
- P - FIRING CIRCUIT CABLE

- Q - CABLE HOOKS
- R { FIRING CIRCUIT RECEPTACLE  
BOX INLET
- S { LIGHTING CIRCUIT RECEPTACLE  
BOX INLET
- T { CABLE TO AZIMUTH  
POINTER LAMP
- U - LIGHTING CIRCUIT CABLE
- V { AZIMUTH POINTER  
RECEPTACLE BOX
- W - GROUND ON MORTAR
- X - CIRCUIT BREAKER CONTACT
- Y - FLEXIBLE CABLE (SHORT)
- Z - BRASS SASH CHAIN
- { BOLT
- AA { SNAP  
RING

RA PD 6871

Figure 20—Electrical Equipment Assembly

DESCRIPTION OF CARRIAGE

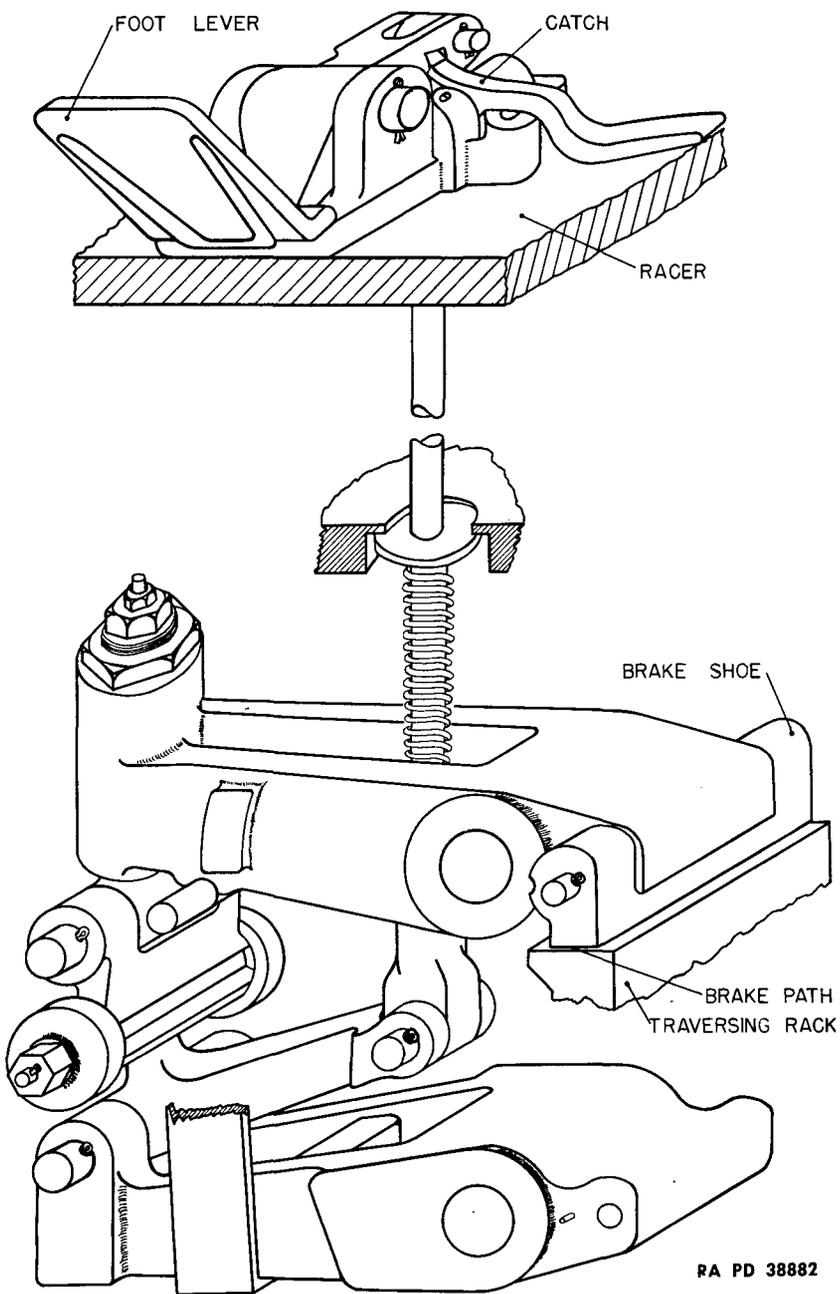

RA PD 38882

Figure 21 - Traversing Brake

12-INCH SEACOAST MATERIEL

Section IV

OPERATION

	Paragraph
General .....	15
To operate the breech mechanism .....	16
To elevate or depress the mortar .....	17
To traverse the mortar .....	18
Points to be observed before firing .....	19
Points to be observed during firing .....	20
To load the mortar .....	21
To fire the mortar .....	22

15. GENERAL.

a. Only information necessary for operation of the mortar and carriage is included in this section. Other sections of this manual cover preparation and handling of ammunition, use of accessories, and operation of subcaliber equipment. For detailed information regarding the duties of the mortar section, see FM 4-55.

16. TO OPERATE THE BREECH MECHANISM.

a. **To Open the Breech.** Pull out on the rotating crank lock. Rotate the rotating crank rapidly in a counterclockwise direction, as indicated by the arrow on the faceplate, until the faceplate is brought to an upright position against the rotating crank upper stop. The rotating crank lock may be released after the first turn on the rotating crank. Rotate the translating roller crank handle rapidly in a counterclockwise direction until the breechblock is moved back out of the breech recess onto the tray. Raise the tray latch handle upward, releasing the tray latch from the tray latch catch. Holding the tray latch handle in this position, grasp the large handle on the left side of the tray and swing the entire mechanism to the right until it becomes locked back in its full open position by the tray back latch (figs. 22 to 28, inclusive).

b. **To Close the Breech.** Lift up on the handle of the tray back latch to release the latch from the catch. Grasping the handle on the left side of the tray, swing the tray hard against the face of the breech. This will latch the tray latch. Grasp the translating roller crank handle and rotate rapidly in a clockwise direction until breechblock seats in the breech recess. Rotate the rotating crank rapidly in a clockwise direction until the faceplate is brought against its lower stop on the right side of the breech face. The rotating crank lock is spring-actuated and will lock automatically in its seat (figs. 29 and 30).

OPERATION

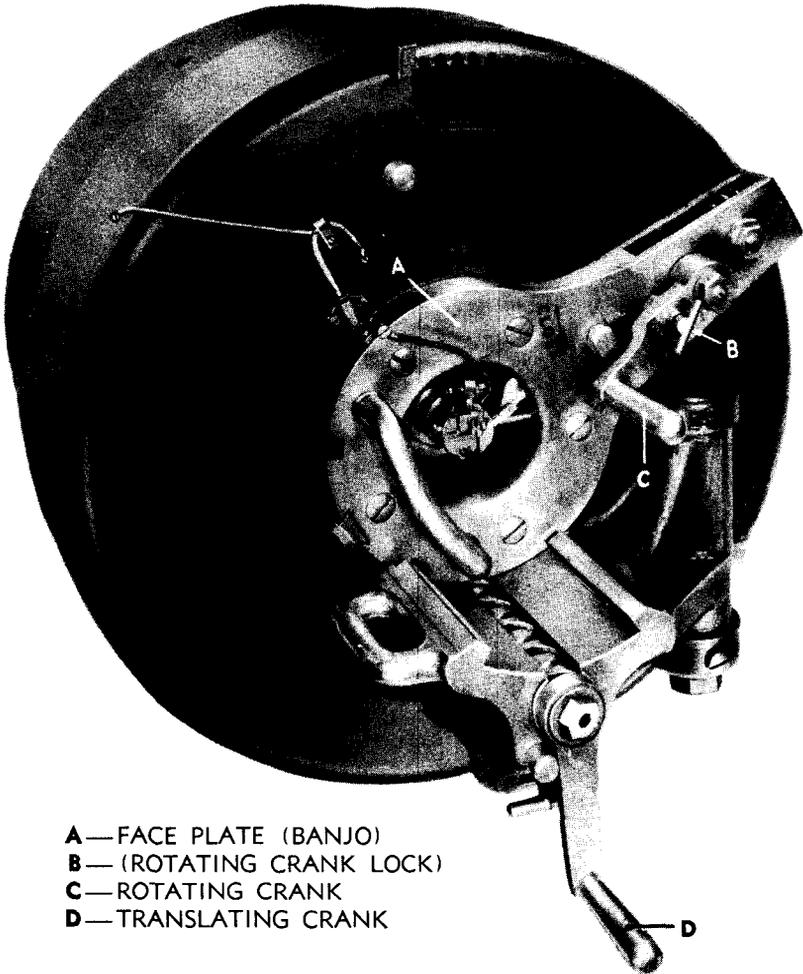

- A—FACE PLATE (BANJO)
- B—(ROTATING CRANK LOCK)
- C—ROTATING CRANK
- D—TRANSLATING CRANK

RA PD 33440

**Figure 22—Breech Mechanism—Closed and Locked**

**17. TO ELEVATE OR DEPRESS THE MORTAR.**

a. **To Elevate.** Pull back on the hand lever to disengage the lock bar from the lock stud in the elevating rack and free the mortar for elevating. Rotate the handwheels in the direction indicated on the direction plates. When the mortar is elevated to the desired firing angle, lock the elevating shaft in position by means of the hand nut on the left end of the shaft.

b. **To Depress the Mortar to Loading Position.** Release the hand nut and depress the mortar by rotating the handwheel until the spring-

12-INCH SEACOAST MATERIEL

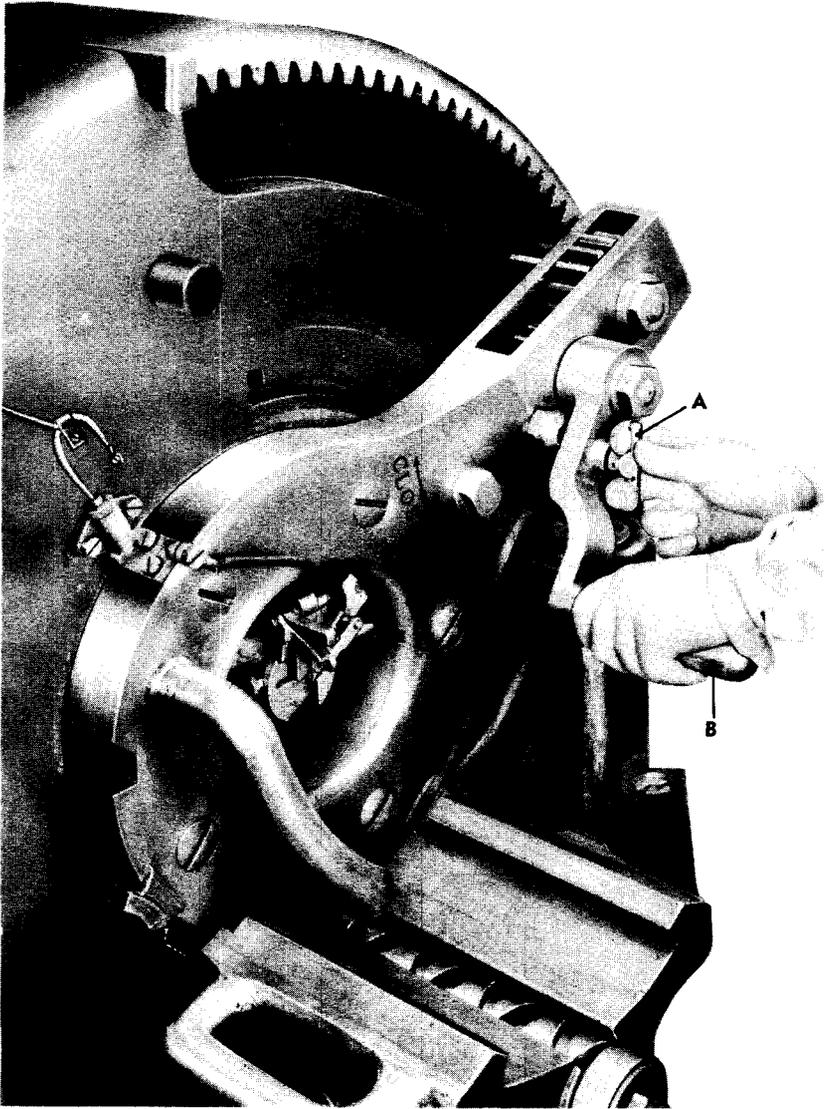

A—RELEASING ROTATING CRANK LOCK

B—TURNING ROTATING CRANK

RA PD 33441

Figure 23—Operation of Rotating Crank Lock and Rotating Crank

**OPERATION**

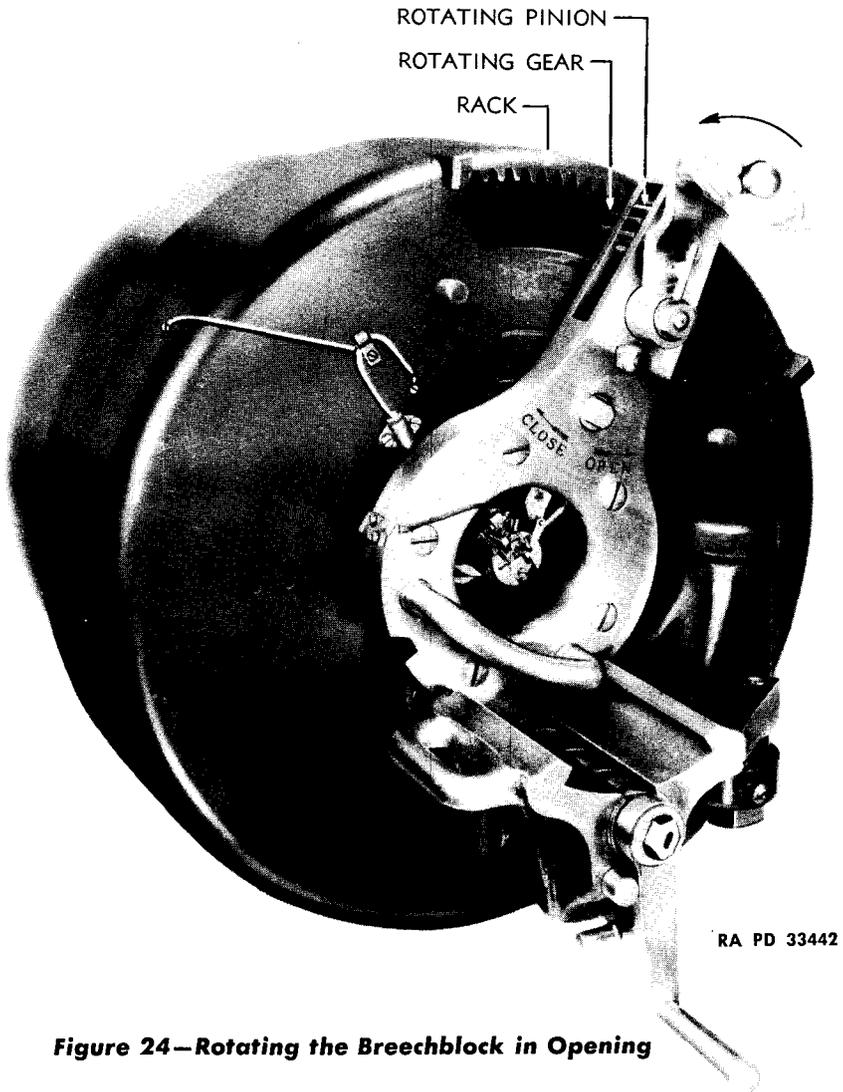

**Figure 24—Rotating the Breechblock in Opening**

actuated lock bar of the elevating locking device automatically engages the lock stud in the elevating rack to lock the mortar in horizontal position. Locking insures against accidental elevation of the mortar during loading operations.

**18. TO TRAVERSE THE MORTAR.**

a. The traversing handwheel is located on the right side of the mortar. A direction plate on the handwheel indicates which way it should be turned to traverse the mortar.

12-INCH SEACOAST MATERIEL

FACEPLATE IN EXTREME POSITION FOR OPENING

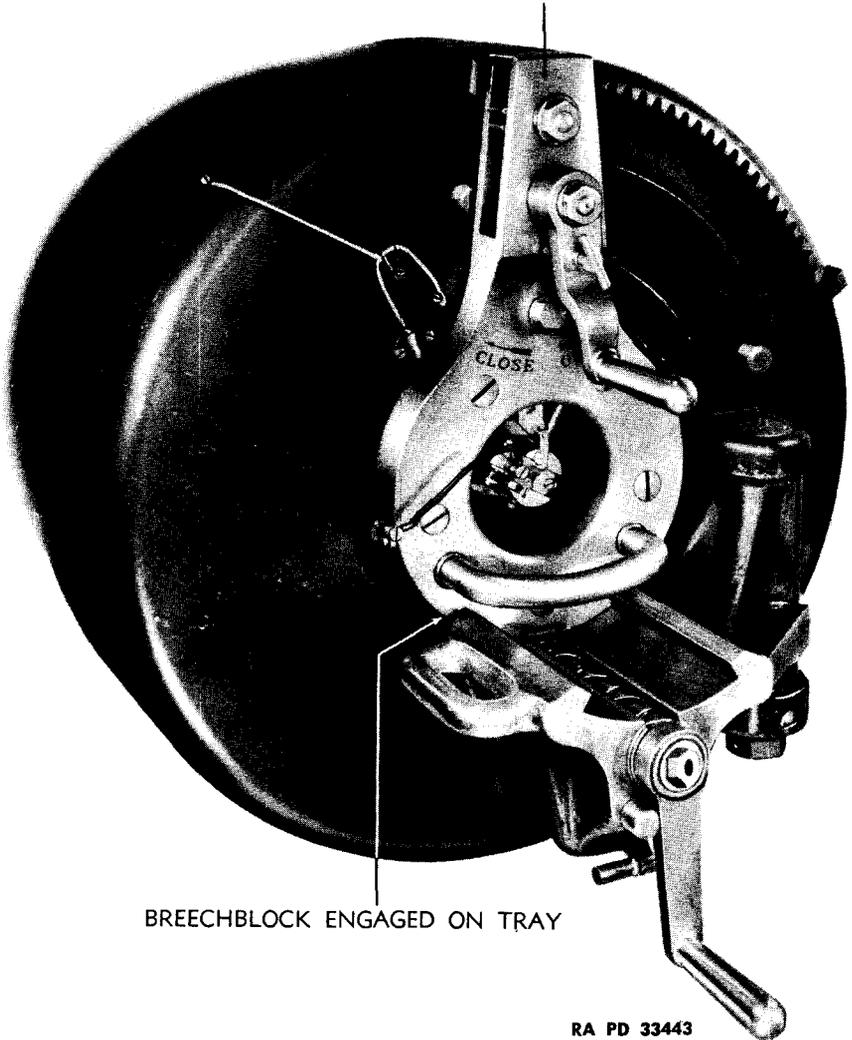

BREECHBLOCK ENGAGED ON TRAY

RA PD 33443

**Figure 25—Breechblock Fully Rotated—Ready to Move Back onto Tray**

b. Before traversing, free movement of the mortar is obtained in releasing the traversing brake by depressing the foot pedal until it is engaged with the foot pedal catch.

c. Depressing the foot pedal catch releases the foot pedal, thereby applying the traversing brake.

## OPERATION

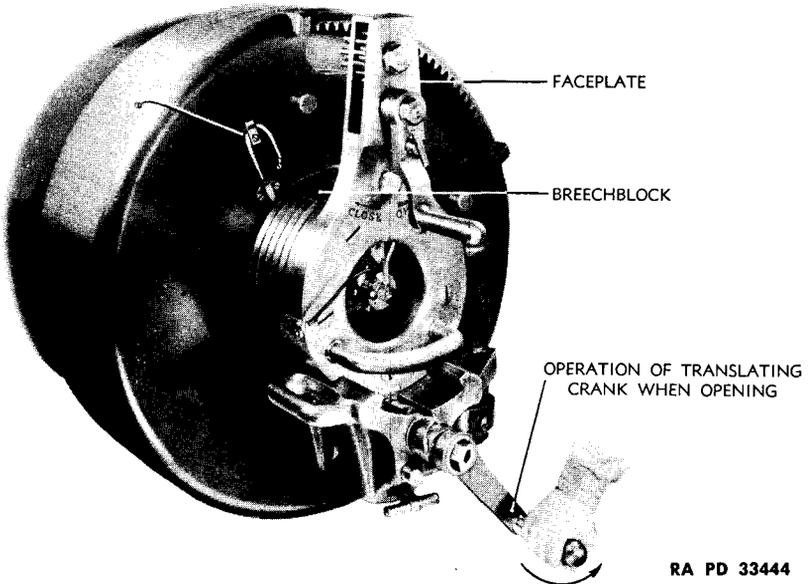

**Figure 26—Breechblock Moving Back onto Tray**

### 19. POINTS TO BE OBSERVED BEFORE FIRING.

a. **Electrical Contacts.** Before firing, all electrical contacts should be examined to see that the firing circuit is complete. This may be accomplished by using a test lamp or by firing a primer.

b. **Pressure Plug Seats.** The pressure plug seats in the obturator head should be closed either by the dummy plugs or pressure gages. A copper washer must be in place beneath the dummy plugs or pressure gages during firing to protect the screw threads from the powder gases.

c. **Obturator Spindle Nut.** The obturator spindle nut should always be screwed up, so that there is sufficient friction to make a slight effort necessary to turn the obturator in its seat.

d. **Gas Check Pad.** Apply engine oil to the gas check pad and rub in well.

e. **Preparation for Measuring the Length of Recoil.** Make several turns with fine twine around the piston rod, tying it tightly just where the piston rod enters the upper stuffing box (par. 20 e).

12-INCH SEACOAST MATERIEL

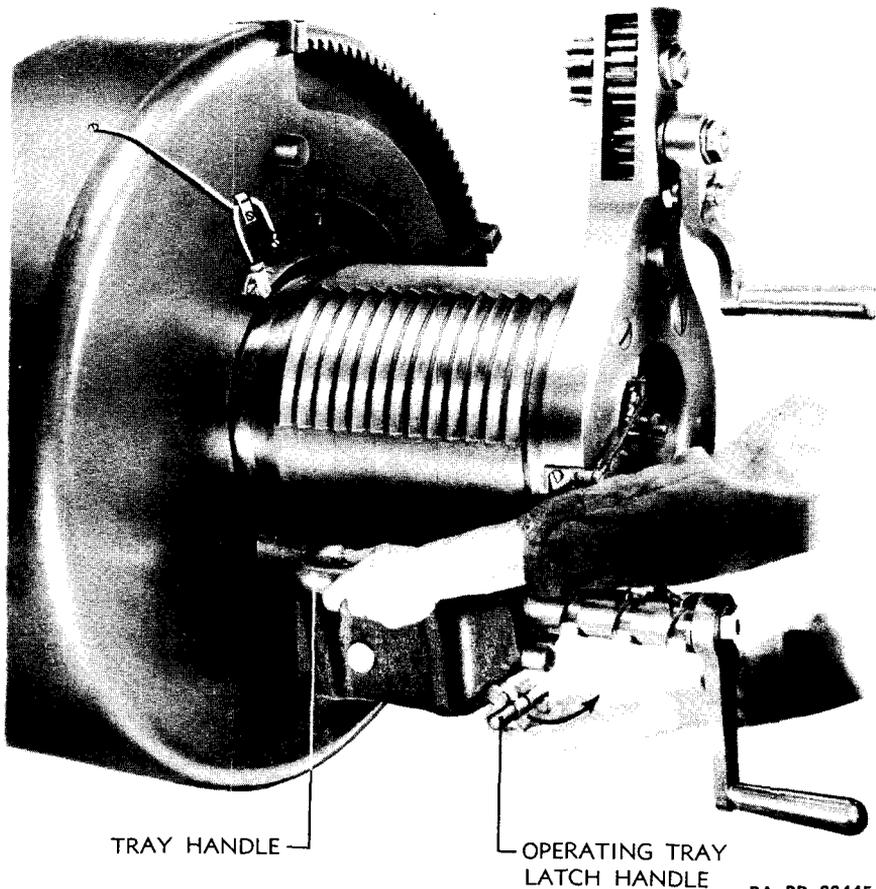

**Figure 27—Method of Swinging Breechblock and Tray Open**

**20. POINTS TO BE OBSERVED DURING FIRING.**

a. **Caution.** If the mortar fails to fire either when the firing magneto lever is raised or when the lanyard is pulled, the following safety precautions must be observed:

- (1) Stand clear of the path of recoil.
- (2) Keep the mortar at firing elevation. Do not depress the piece.
- (3) Do not under any circumstances attempt to open the breech.
- (4) Do not attempt to remove the primer by hand. Use the butterfly net improvised for this purpose. Taking care to stand clear of the path of recoil, raise the slide of the firing mechanism by means of the hook at the end of the pole and eject the primer. Catch primer in the net and examine it. Follow the procedure in paragraph 23.

OPERATION

RA PD 33446

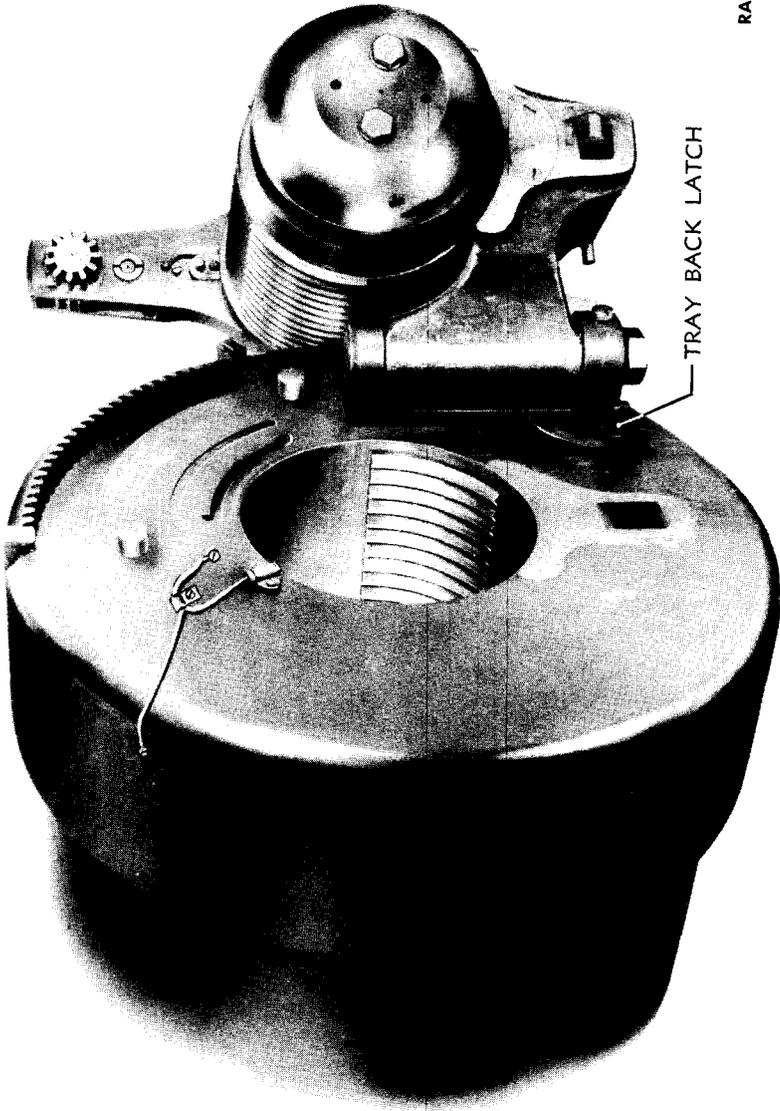
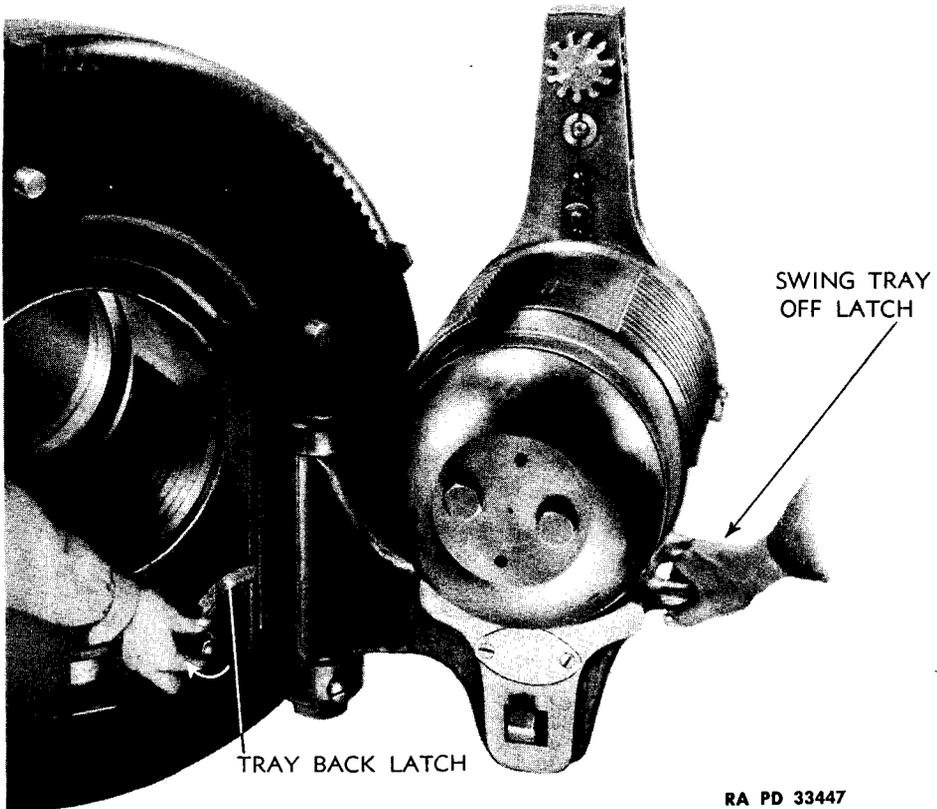

Figure 28 — Breech Fully Open — Ready for Loading

## 12-INCH SEACOAST MATERIEL



**Figure 29—Releasing Tray Back Latch for Closing**

RA PD 33447

**b. Powder Chamber.** After each round is fired, the powder chamber of the mortar should be swabbed out with a bore sponge saturated with cleaning solution (par. 26). After swabbing, examine the bore of the mortar and remove any particles of wadding or unburned powder remaining.

**c. Obturator Head.** Remove the powder stains from the obturator head after each round fired, using a cloth or rag moistened with cleaning solution (par. 26).

**d. Gas Check Pad.** The gas check pad should be oiled frequently enough to keep it compressible. A pad of proper resiliency will yield slightly under heavy pressure from the thumbs.

**e. To Measure the Recoil.** Normally the length of recoil will be checked after each round is fired. The height of the twine (par. 19 e) above the stuffing box after firing will indicate the length of recoil. The maximum length of recoil (M1896MI carriage) is 23 inches. The maximum length of recoil (M1896MII carriage) is 24 inches. If the length of recoil reaches the maximum, the cylinder should be filled to the level

**OPERATION**



A—TRAY BACK LATCH CATCH  
B—TRAY BACK LATCH

RA PD 33456

**Figure 30—Tray Back Latch and Tray Back Latch Catch**

### **12-INCH SEACOAST MATERIEL**

of the filling holes (par. 25 c), and a check should be made to insure that the mortar is returning fully into battery, with the counterrecoil springs holding the cross head securely against the buffers. If the recoil continues to be maximum, it indicates a dangerous condition of the materiel. Stop firing, notify ordnance maintenance personnel.

f. When firing by electrical primer, do not connect the safety firing plug until the mortar is elevated past 45 degrees.

#### **21. TO LOAD THE MORTAR.**

a. **Projectile.** With the mortar at the proper loading angle (zero deg), open the breech. Run the shot truck, with the projectile on it, up against the breech face of the mortar, where it is brought to a gradual stop by the buffer ram. Set the brakes on the shot truck. Place the rammer against the base of the projectile and ram the projectile home.

b. **Powder.** Place the powder on the tray of the shot truck and push it into the powder chamber by hand a distance that will allow the breechblock to touch the powder charge. Caution to have the igniter pad to the rear. Remove the shot truck. Close the breechblock.

c. **Primer.** Raise the slide of the firing mechanism and insert the primer. Lower the slide, making sure that the lip of the ejector engages behind the rim of the primer.

d. The mortar is now loaded.

#### **22. TO FIRE THE MORTAR.**

a. **General.** There are two methods of firing the mortar: Electrically, by means of the firing magneto, using an electric primer and manually, by means of the lanyard, using a friction primer. Normally the piece is fired electrically, using the magneto.

(1) To fire the mortar by the firing magneto: As the mortar is being elevated, the firing plug may be inserted into the firing plug box when an elevation of 45 degrees is reached. When the elevation and azimuth are properly set and clamped, the piece is fired at the proper time by a moderately quick pull on the operating lever of the firing magnetó. The latch which holds the lever against accidental operation is released by grasping the lever handle. After the lever is released, it returns to its normal position by its own weight assisted by a lever spring.

(2) To fire the mortar by lanyard: Attach the bridle ring on the short lanyard to the bridle ring catch. After the mortar has been elevated beyond 43 degrees, attach the hook of the short lanyard to the eye on the firing leaf. The long lanyard is then attached to the eye of the stopper button in the racer. When the elevation and azimuth have been set and clamped, the mortar is fired at the proper time by a quick, strong pull (not a jerk) from a position directly in rear of the piece.

Section V

**MALFUNCTION AND CORRECTION**

	Paragraph
Mortar .....	23
Carriage .....	24

**23. MORTAR.**

Malfunction	Cause	Correction
<p>a. Fails to fire (with electric primer).</p>	<p>a. Misfire, defective primer, interrupted electrical circuit.</p>	<p>a. Keep the mortar at firing elevation. Stand clear of the path of recoil. Eject the primer, using the butterfly net (par. 20 a(4)). <i>Examine the ejected primer.</i> If examination shows that the primer has fired, a misfire has occurred. Proceed as in (1) below. If examination shows that the primer has not fired, there may be a broken electrical circuit. To correct, proceed as in (2) below.</p>
	<p>(1) Misfire, defective primer.</p>	<p>(1) If the primer fires and the piece fails to fire, <i>keep the mortar in the elevated position and keep it pointed at the target or in a clear field of fire for 10 minutes.</i> After this, insert another primer in the firing mechanism and resume firing.</p>
	<p>(2) Misfire, interrupted electrical circuit.</p>	<p>(2) Repeat the attempt to fire with two additional primers. If this attempt fails, try one more primer. If all three primers fail to fire, there is probably an interruption in the electrical circuit, and the procedure in (3) should be followed.</p>

12-INCH SEACOAST MATERIEL

Malfunction	Cause	Correction
b. Fails to fire (with friction primer).	(3) Loose connections or contact. Firing circuit broken.	(3) Check the electrical system. Tighten loose connections or contacts. Replace broken wires. If the primer still does not fire, notify ordnance maintenance personnel.
	b. Misfire, defective primer.	b. Keep the mortar at firing elevation. Stand clear of the path of recoil. Eject the primer, using the butterfly net (par. 20 a(4)). <i>Examine the primer.</i> If examination shows that the primer has fired, a misfire has occurred. Follow procedure (1) below. If the primer has not fired, it may be defective. Follow procedure (2) below.
	(1) Misfire.	(1) <i>If the primer fires and the piece fails to fire, keep the mortar in the elevated position and keep it pointed at the target or in a clear field of fire for 10 minutes.</i> After this, insert another primer in the firing mechanism and resume firing.
	(2) Misfire, defective primer.	(2) Insert a new primer and set the defective one aside.
c. Seized breechblock.		c. Notify ordnance maintenance personnel.
d. Escape of gases.	d. Bruises on gas check pad or torn covering. Burred or ruptured split rings.	d. Replace the damaged obturator parts.
e. Burred or corroded head on primer, or primer fails to be ejected.	e. Ruptured primer. Failure to ream primer seat.	e. Ream primer seat.

## MALFUNCTION AND CORRECTION

<b>Malfunction</b>	<b>Cause</b>	<b>Correction</b>
f. Broken or damaged parts of the firing and breech mechanism.		f. Parts may be replaced by the using arm, if the facilities are available.

### 24. CARRIAGE.

<b>Malfunction</b>	<b>Cause</b>	<b>Correction</b>
a. Loose elevating rack.	a. The firing stresses are apt to cause the bolts to come loose.	a. Tighten the bolts.
b. Failure of mortar to return fully into battery.	b. Counter-recoil springs out of adjustment.	b. The counterrecoil springs are properly adjusted when, with the mortar loaded and at maximum firing elevation, the cross heads are held in contact with the buffer plate.

(1) To adjust, loosen the lock nuts on the spring rods. Tighten each adjusting nut a little at a time until the correct adjustment is obtained. Prevent the rods from turning by means of a wrench on the fixed nuts below the lock nuts. Occasionally during adjustment, release the elevating lock and jar the mortar against the depression stop on the top carriage by means of the elevating handwheels.

(2) When the proper adjustment is obtained, tighten the lock nuts securely against the adjusting nuts.

12-INCH SEACOAST MATERIEL

Section VI

CARE AND PRESERVATION

	Paragraph
General .....	25
After firing .....	26
Disassembly and cleaning of breech mechanism .....	27
Disassembly and cleaning of firing mechanism .....	28
Lubrication instructions .....	29
Preparation for active season .....	30
Preparation for inactive season .....	31
Service of mortar and carriage during inactivity .....	32
Servicing materials .....	33

25. GENERAL.

a. Routine service of the mortar and carriage is described in this section. Servicing of the ammunition, accessories and subcaliber equipment is covered in sections IX, X, XI, and XII.

b. The matter of keeping all parts of the mortar and carriage in condition is of vital importance. Proper lubrication and care are absolutely necessary to obtain good performance.

c. All parts provided with oilholes or grease cups should be lubricated at the correct intervals. When carriages are in use for daily drills, a thorough lubrication twice a week should be sufficient for all but the most severely used parts. The recoil cylinders must be filled before firing is commenced. To fill the cylinders, remove the plugs in the filling holes and add OIL, recoil, light, until the oil comes up to the level of filling holes. Approximately 9½ gallons of recoil oil are required to fill the recoil cylinders. Replace the plugs.

d. When the materiel is not in use, all covers furnished should be in place.

e. When the mortar is being manned continually, the firing mechanism should be assembled on the mortar and left assembled until the mortar is not manned. It should then be disassembled, put in the small box provided for it, and stored in the armament chest.

26. AFTER FIRING.

a. **Bore.** After firing, and while the mortar is still warm, the bore should be cleaned. Swab the bore with a solution of ½ to 1 pound of SODA ASH or 1 to 1½ pounds of SAL SODA to each gallon of water. This solution should be warm when used. When all powder fouling has been removed, swab the bore with clear water. Then dry the bore, using the sponge covered with burlap or cleaning cloths. Oil the bore with

## CARE AND PRESERVATION

OIL, engine, SAE 10 (for temperatures below 32 F), or SAE 30 (for temperatures above 32 F).

**b. Breech Mechanism.** The breech mechanism should be disassembled, cleaned and oiled immediately after firing. This is especially important as no provision is made for oiling by means of oilers or oil channels.

**c. Firing Mechanism.**

(1) Since the clearances between parts of the firing mechanism are very small, care must be exercised to keep the mechanism well oiled and free from rust and dirt. The mechanism should always be disassembled, cleaned, and oiled immediately after firing.

(2) Occasionally, during firing, residue works its way back through the vent hole in the spindle to the primer seat, causing the primer to seat improperly. After firing, this residue should be removed by reaming out the primer seat with the primer seat cleaning reamer which is carried in the firing mechanism box. At this time the vent hole in the spindle should also be cleaned out, using the flannel patches and vent cleaning rod provided.

## 27. DISASSEMBLY AND CLEANING OF BREECH MECHANISM.

**a. Disassembly of the Breech Mechanism for Cleaning.**

(1) With the breech mechanism closed and locked by means of the rotating crank lock, remove firing cable. Remove firing mechanism by drawing the hinged collar catch to the rear, unscrewing the hinged collar from the housing, and pulling the firing mechanism off the obturator spindle (fig. 31).

(2) Remove the hinged collar from the obturator spindle (fig. 32).

(3) Disassemble the safety bar slide.

(4) Release the rotating crank lock. Rotate the breechblock by means of the rotating crank until the faceplate comes against the upper stop.

(5) Turn the translating crank, translating the breechblock back onto the tray and swing the breechblock and tray open approximately 90 degrees.

(6) Loosen the obturator nut clamping screw and remove the obturator spindle nut. (Note the left-hand thread feature (figs. 5 and 33)).

(7) Remove obturator spindle washers. (Note that these four washers are alternately bronze and steel with a bronze washer in front (fig. 5)).

(8) Fit a rope noose in the form of a sling around the obturator spindle. Withdraw the spindle from the breechblock, and by means of a sling lower the spindle carefully to a working position (fig. 34).

(9) Remove the filling-in disk, split rings, and gas check pad from the obturator spindle (fig. 5).

12-INCH SEACOAST MATERIEL

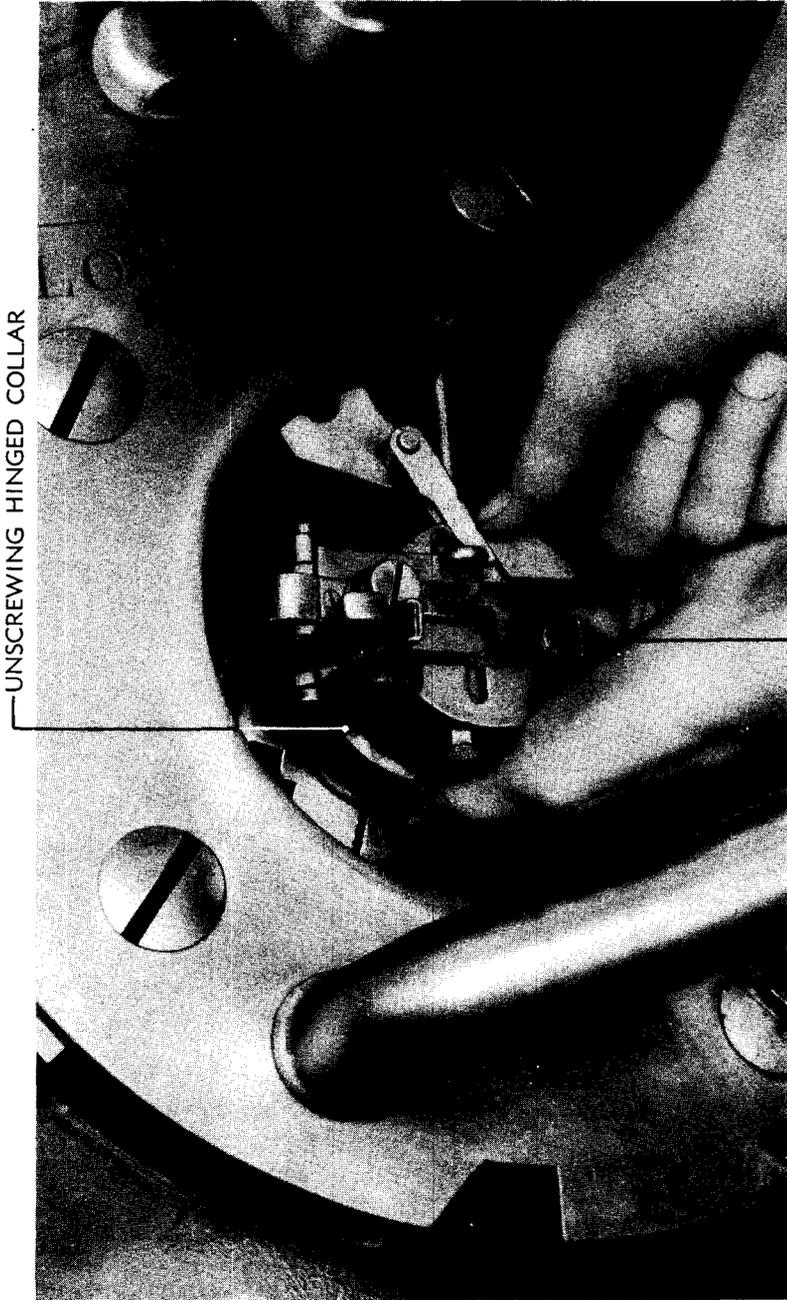

RA PD 33448

Figure 31 — Removing the Seacoast Firing Mechanism M1903

CARE AND PRESERVATION

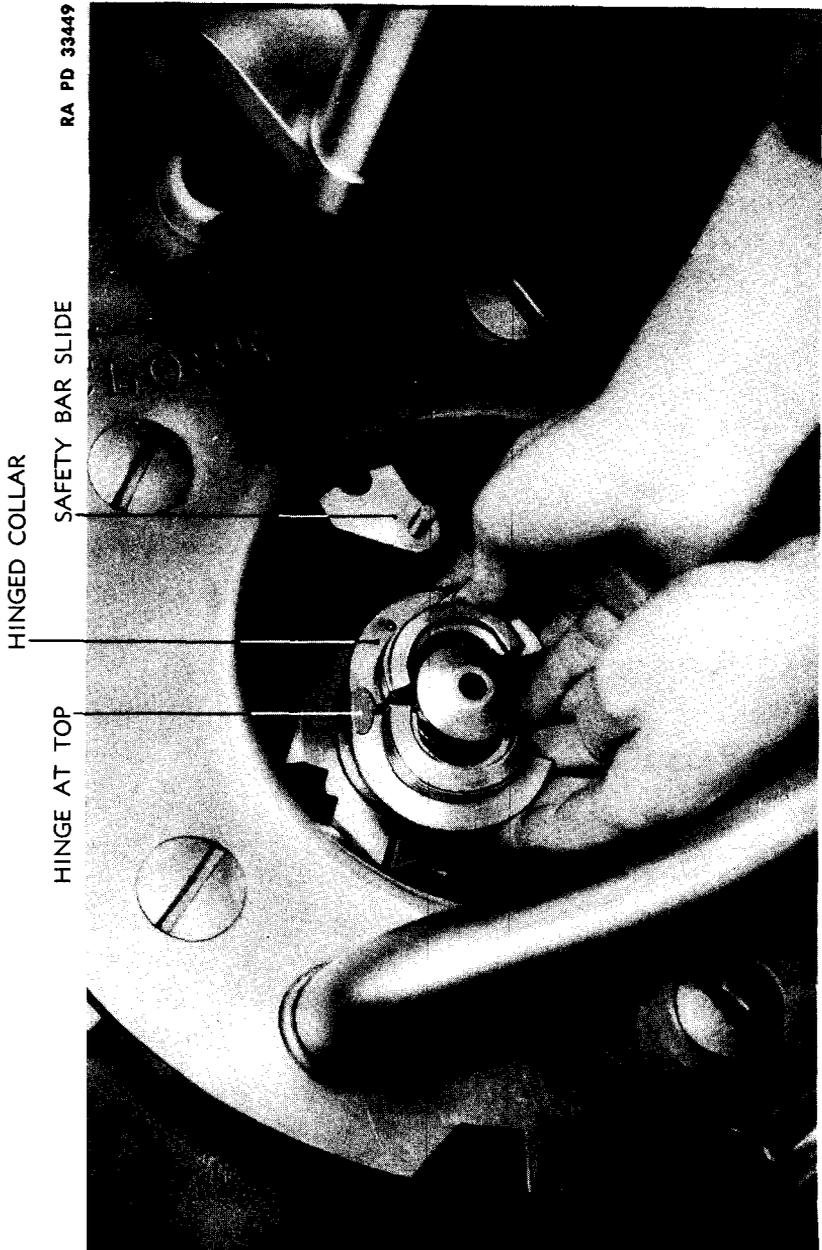
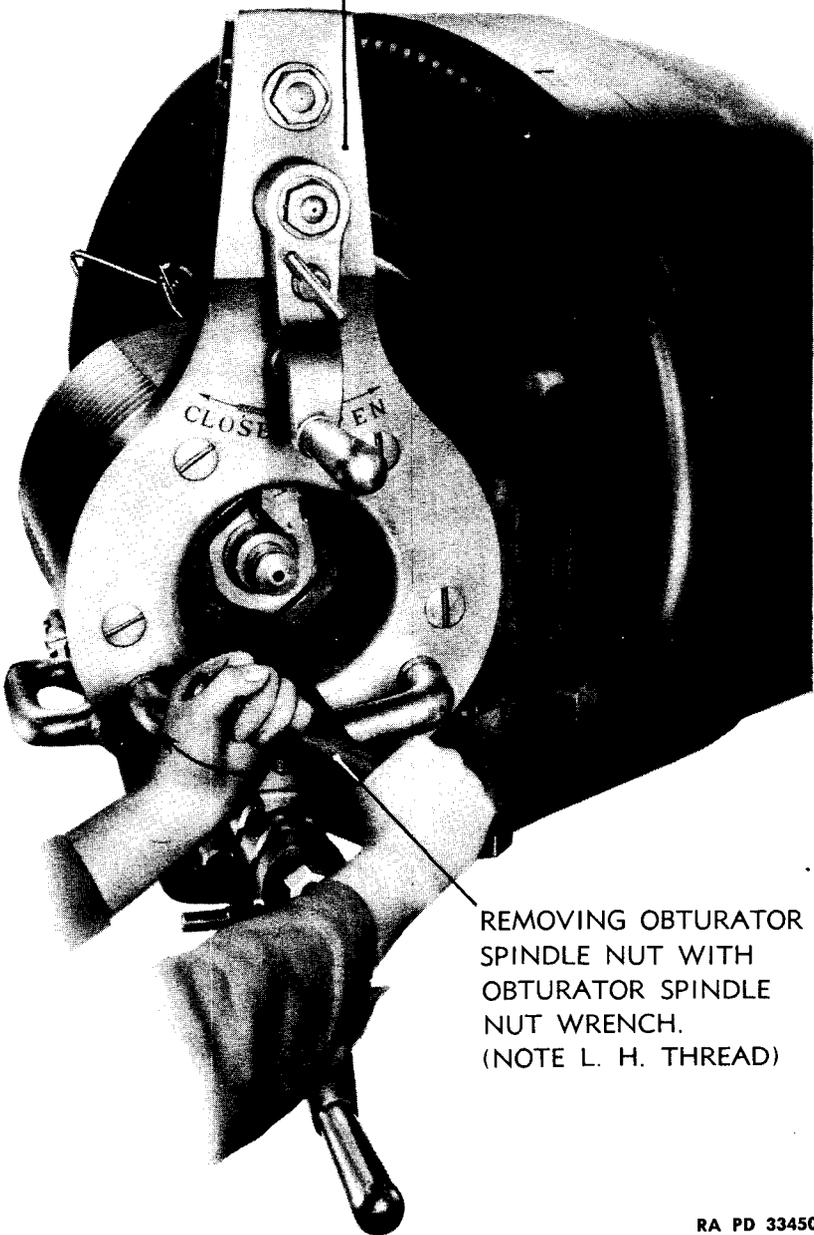

Figure 32 — Method of Removing Seacoast Firing Mechanism Hinged Collar

12-INCH SEACOAST MATERIEL

BREECHBLOCK AND  
TRAY SWUNG OUT  
OF BREECH RECESS



REMOVING OBTURATOR  
SPINDLE NUT WITH  
OBTURATOR SPINDLE  
NUT WRENCH.  
(NOTE L. H. THREAD)

RA PD 33450

Figure 33—Method of Removing Obturator Spindle Nut

CARE AND PRESERVATION

RA PD 33451

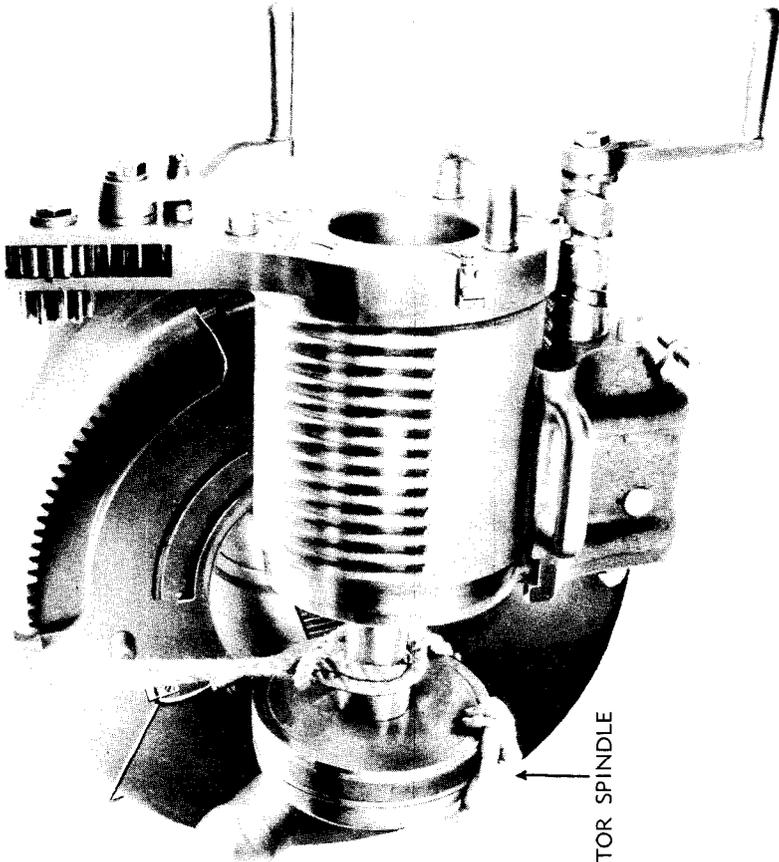

STEADYING THE OBTURATOR SPINDLE

Figure 34—Method of Removing Obturator Spindle by Means of Sling

### 12-INCH SEACOAST MATERIEL

(10) Pass a loop of heavy rope through the obturator spindle hole of the breechblock, as shown in figure 35. Fasten the rope sling to an overhead crane or garrison gin. Care should be taken to apply the rope noose around the breechblock, in the manner shown in figure 35, in order to offset any tipping of the mechanism due to the unbalanced weight of the faceplate.

(11) Translate the breechblock off the tray by means of the translating roller and crank in the same manner as closing the breech. Care should be taken to steady the breechblock towards the end of its travel off the tray, in order to prevent tipping or dropping the entire weight of the breechblock on the sling too suddenly.

(12) Rotate the translating roller in a counterclockwise direction and withdraw it from its seat (fig.36).

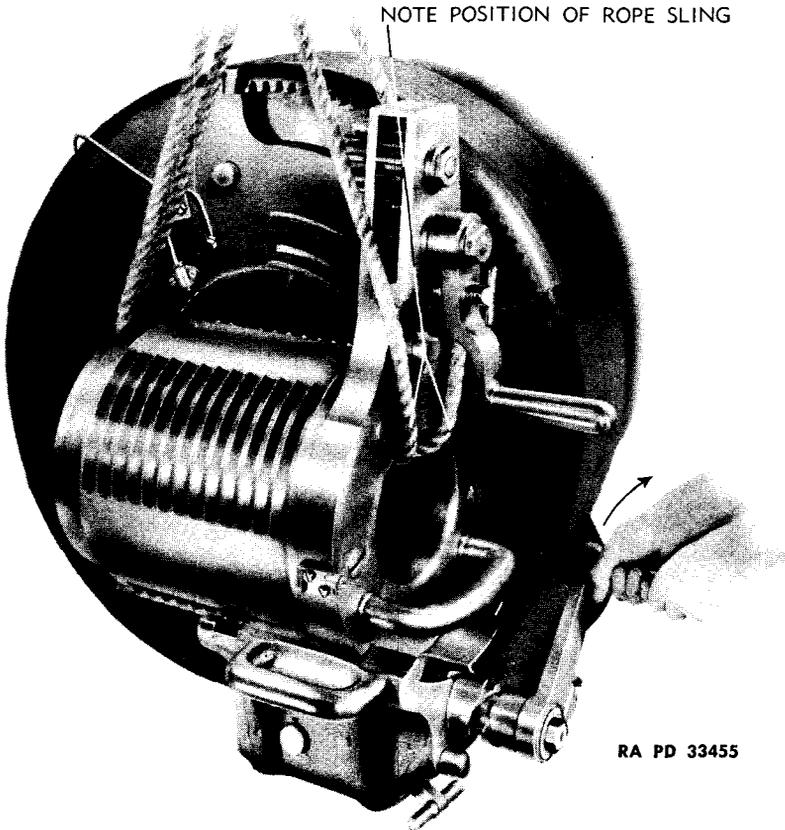

**Figure 35—Method of Disassembling Breechblock from Tray  
by Means of Translating Crank**

CARE AND PRESERVATION

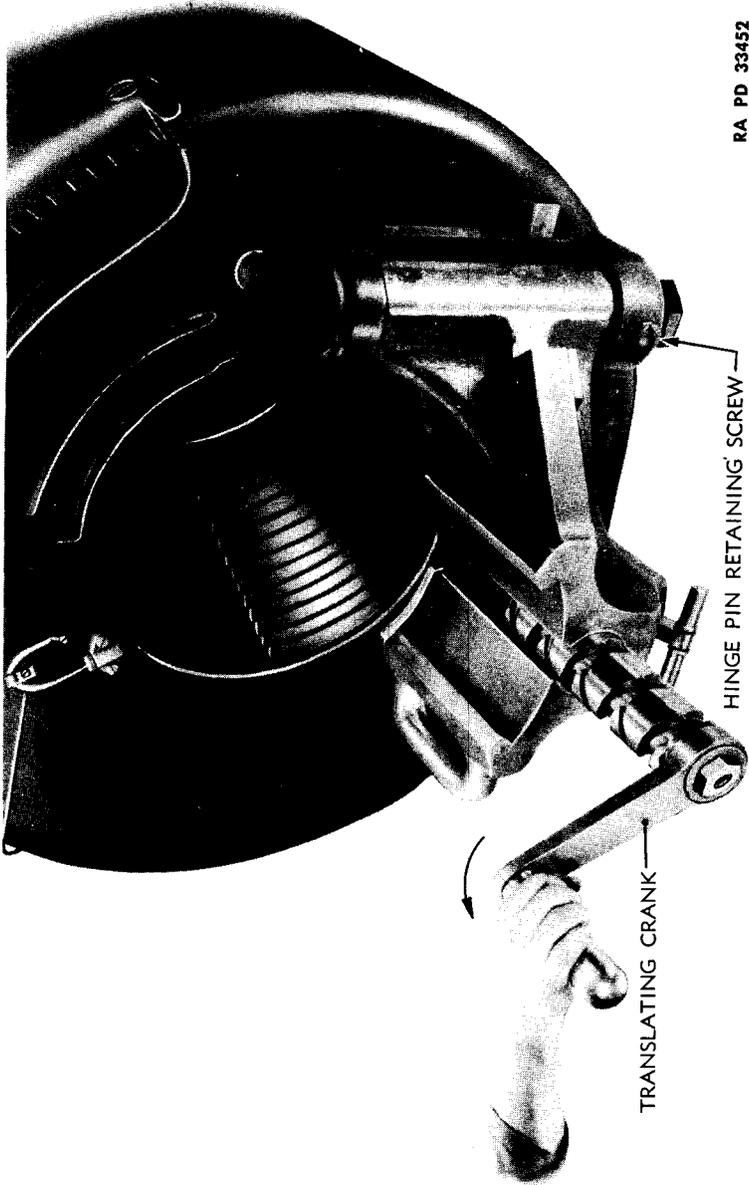

RA PD 33452

**Figure 36—Removing Translating Crank**

**12-INCH SEACOAST MATERIEL**

(13) Remove the translating crank from the translating roller as follows: drift out the translating crank nut pin. Remove the translating crank nut. The crank may then be removed directly.

(14) Remove the cotter pin and tray latch pivot washer from the tray latch pivot. Drift out the tray latch pivot, releasing tray latch, at the same time removing the tray spring bolt and tray spring bolt spring.

(15) Sling the tray, as shown on figure 37. See that the hinge pin retaining screw (fig. 36) is tight in order to prevent hinge pin from turning when removing the hinge pin nut. Remove the taper pin from the hinge pin nut; unscrew the hinge pin nut. Remove the hinge pin retaining screw. Steadying the tray in the sling, drift the hinge pin out of the seat, thereby releasing the tray.

(16) Vigilance must be exercised to detect any cuts or abrasions on the threads of the breechblock or breech recess. Scores or bruises on the threads should be reported to ordnance maintenance personnel.

**b. Cleaning and Oiling.** Clean all bright surfaces with SOLVENT, dry-cleaning. Be sure all traces of powder stains or rust deposits are removed, using CLOTH, crocus, if necessary. Wipe the surfaces dry and remove all particles of grit by using clean rags. Lubricate with a thin film of OIL, engine, seasonal grade. Apply OIL, engine, seasonal grade, to the obturator pad and rub in well.

**c. Assembly of the Breech Mechanism.**

(1) By means of the sling, adjust the tray in place between the hinge lugs. Insert the hinge pin. Put in the hinge pin retaining screw so that it enters its mating hole in the hinge pin, and screw up tight. Screw on hinge pin nut and insert taper pin. The tray will now be held in place by the hinge pin and the sling may be removed.

(2) Reassemble tray latch, tray latch pivot, tray spring bolt spring and tray spring bolt in place.

(3) Open the tray approximately 90 degrees from the breech recess in order to give operating space to assemble the breechblock. Assemble the breechblock onto the tray by means of a sling, making sure that the grooves of the breechblock match the corresponding slides on the tray. With the gas check pad, split rings, filling-in disk in place on the obturator spindle, assemble the obturator spindle into its seat in the breechblock. Assemble alternately the bronze and steel obturator washers, beginning with the bronze washer. Screw on the obturator spindle nut and tighten sufficiently to secure all parts firmly in place. The spindle nut should be adjusted so that one man can just turn the mushroom head of the obturator spindle by hand. When properly adjusted, lock the spindle nut with the clamping screw.

(4) Swing the tray around against the face of the breech and push

CARE AND PRESERVATION

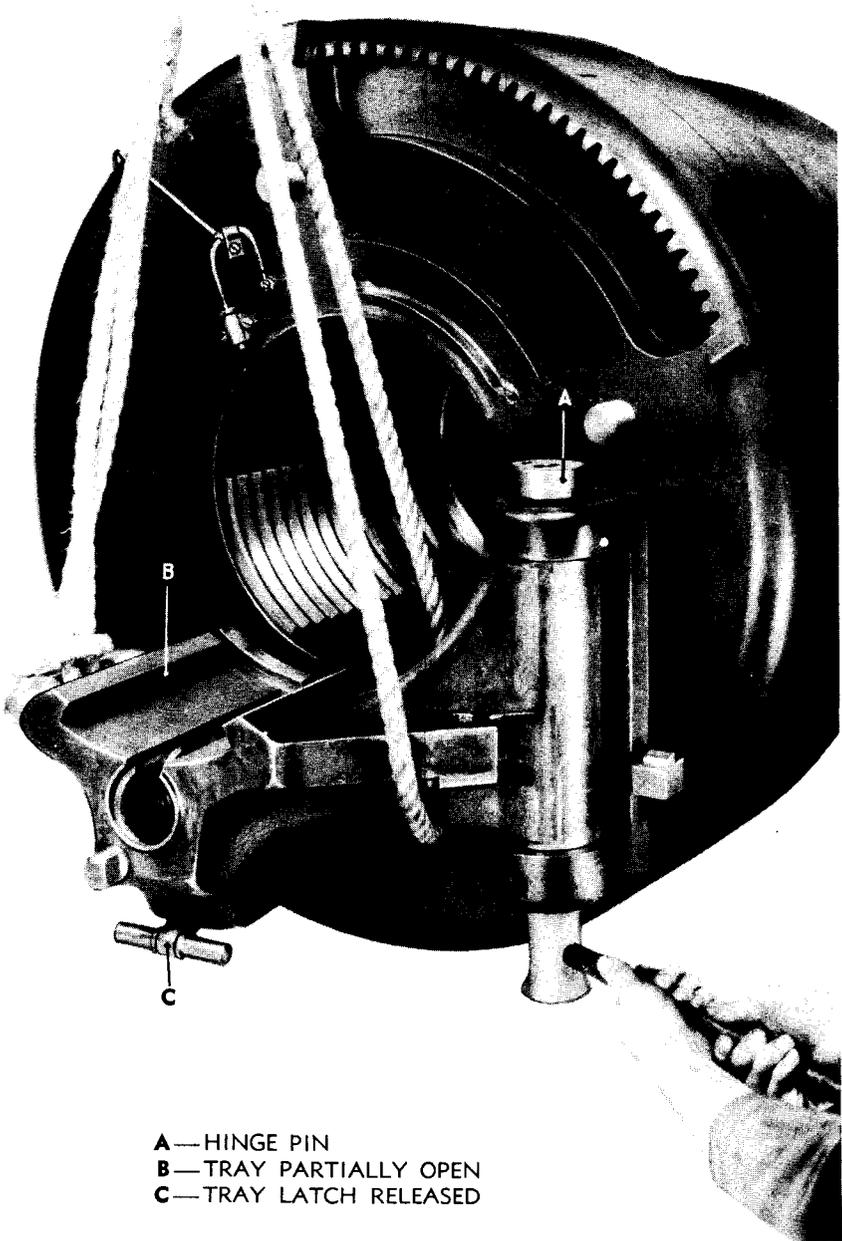

RA PD 33454

*Figure 37—Method of Slinging and Disassembling Tray*

### **12-INCH SEACOAST MATERIEL**

the breechblock home. Rotate the breechblock slightly by means of the rotating crank, and assemble the translating roller in place.

(5) Put on translating crank.

(6) Clasp the hinged collar over the end of the spindle, with the two ribs of the collar engaging in the corresponding grooves of the spindle end with the hinge at the top.

(7) Take the firing mechanism housing in the right hand, the collar in the left hand, and place the housing over the end of the collar. Screw the collar into the housing until the catch on the housing engages the collar. Meanwhile, see that the guide bar which projects from the right side of the mechanism enters its groove in the breechblock, and that the pin on the safety bar slide (attached to the mortar) enters the hole in the outer end of the safety bar of the mechanism.

(8) Connect the firing cable.

### **28. DISASSEMBLY AND CLEANING OF FIRING MECHANISM.**

**a. Disassembly of the Firing Mechanism for Cleaning** (figs. 7, 8, 9, 31 and 32).

(1) Remove the slide from the housing; draw the slide stop out to the left as far as it will go. The slide may then be lifted from the housing.

(2) To remove the firing leaf and slide catch from the slide, start the split pin which passes through the leaf pivot by pressing upon it, and then draw it out. The pivot is then free to be removed, and its removal frees the leaf and slide catch from the slide.

(3) The collar catch may be removed by unscrewing the screw at the lower edge of the housing.

(4) The slide stop may be removed by unscrewing it from the housing with the wrench provided for that purpose. The slide stop should not be removed except when necessary to repair it or to replace a broken spring.

(5) The contact clip may be removed from the leaf by unscrewing the nut on the underside of the leaf.

**b. Cleaning and Oiling.** Clean all bright surfaces with SOLVENT, dry-cleaning. Be sure all traces of powder stains or rust deposits are removed, using CLOTH, crocus, if necessary. Wipe the surfaces dry and remove all particles of grit by using clean rags. Lubricate with a thin film of OIL, engine, seasonal grade.

### **29. LUBRICATION INSTRUCTIONS.**

**a. General.** Excessive wear can be prevented and the life of the mortar and carriage increased by keeping the materiel clean and well lubricated. Particular attention should be given to the lubrication of sliding surfaces of the breech mechanism and to other bearing surfaces

## CARE AND PRESERVATION

that do not contain oil holes, plugs, or grease fittings. Parts should be manipulated while the lubricant is being applied so as to distribute the lubricant over the bearing surfaces. Only the prescribed lubricants as listed in paragraph 33 will be used.

### b. Elevating Rack, Pinion and Open Gears.

(1) The teeth of the elevating and traversing racks and open type of elevating gears require little lubrication, but as a protection against rust they must be covered with a thin coat of OIL, engine, seasonal grade. Dust and grit will adhere to this oily film. Consequently, the teeth must be thoroughly cleaned and fresh oil applied before elevating or traversing the gun; otherwise, the grit will cause rapid wear of both racks and gears.

(2) If considerable dust is present when gun is operated, the oil should be removed from the teeth and they should remain dry until action is over. If the surfaces are dry, there is less wear than when coated with a lubricant contaminated with grit.

c. **Elevating and Traversing Gear Cases.** Gear cases must be flushed when changing grades of oil to clean them of sediment and moisture that collects in them. In localities where atmospheric temperatures permit the use of the same grade the year round, they must be drained and flushed once a year. Follow the procedure below:

(1) Drain used oil and replace drain plug.

(2) Fill cases approximately half full with OIL, engine, SAE 10, and manipulate the gears rapidly for 5 minutes.

(3) Drain flushing oil, replace plug and fill case to level plug opening with the grade of engine oil specified on lubrication guide (fig. 38).

d. **Traversing Rollers.** Since they are below ground level where grit and dirt can easily reach them, the traversing rollers pick up relatively large quantities of abrasive and water; therefore, they must be cleaned every three months. The proper procedure is as follows:

(1) Scrub rollers and racer with a brush dipped in SOLVENT, dry-cleaning.

(2) Traverse the carriage a few degrees and repeat the operation.

(3) Continue traversing and washing until all dirt and sediment are removed.

(4) When thoroughly dry, lubricate with engine oil as specified on lubrication guide.

(5) Traverse the mortar 360 degrees while lubricating to insure that all surfaces are coated.

(6) Although the traversing rack and rollers are enclosed, dirt and water, contaminating the lubricant, leave deposits that must be removed

### **12-INCH SEACOAST MATERIEL**

from time to time. To avoid damage, the parts must be disassembled and cleaned annually.

**e. Identification of Lubrication Points.** Lubrication fittings are painted red and oilholes are encircled by a red ring for ease in locating. In cases where this is prevented by inaccessibility, red arrows pointing to such handy oilers or oilholes will be painted upon the nearest convenient surface.

**f. Oilholes.** All oilholes must be cleaned out frequently to keep them free from sand and grit. They should habitually be kept closed with the screw plug provided, except during oiling. Before oiling at any hole, wipe off carefully any dirt or grit near the opening that might be carried down into the bearing by the oil.

**g. Receptacles.** The lubricants will be kept in receptacles plainly labeled with their contents. These should always be kept closed to prevent contamination by water, dirt, etc.

**h. Compression Grease Cups.** Where compression grease cups are provided, precautions against dirt or grit must be observed. In filling these cups, do not fill completely, but fill only to the bottom of the bevel at the top of the cup; if too full, the leather packing will become inverted. In putting on the cap, see that the leather follower enters the cup without being caught, cut, or bent by the edge of the cup. Screw the cap down on the cup, using a wrench, if necessary, to secure sufficient power, until the spring rod projects about  $\frac{1}{4}$  inch above the top of the cap. Later, when the spring has recovered and has moved the follower forward, forcing the grease through the tube into the bearings (this will be indicated by the spring rod being pulled into the cap until its nut touches or nearly touches the cap) it will be necessary to screw the cap down on the cup until the spring is again compressed. When the cap is screwed nearly home and the spring rod does not project, it is an indication that the cup should be filled.

### **30. PREPARATION FOR ACTIVE SEASON.**

**a.** At the beginning of the active season, all exposed finished surfaces will be thoroughly cleaned and lubricated. Careful inspection of the condition of finished and unfinished surfaces will be made, and rust and marred paint will be removed. Cleaning and preparation of surfaces for repainting or touching up is covered in paragraph 82.

**b.** If the recoil oil appears dirty or contains sediment, empty and wash out recoil cylinders with SOLVENT, dry-cleaning, and refill the recoil cylinders. Do not remove packing from the stuffing boxes for this operation.

### CARE AND PRESERVATION

c. Clean and lubricate the traversing rollers and roller paths (par. 29 d). Clean the inner side of the dust guard and repaint, as required.

d. Clean and lubricate the traversing and elevating mechanisms (par. 29 b and c). Elevate the mortar and traverse the carriage throughout the 360 degrees.

e. Fill all grease cups; screw cap down until emptied, remove cap and refill. Replace cap and screw two turns.

f. Lubricate the pintle bearing. Four oilholes are provided for this purpose. The carriage must be traversed in order to distribute the oil throughout the whole circumference.

g. Clean and replace all covers.

h. Lubricate all parts that can be reached without disassembly.

### 31. PREPARATION FOR INACTIVE SEASON.

a. At the beginning of an inactive season or when the weapon is to be unused for a considerable time, the obturator spindle with mushroom head, the split ring, and the filling-in disk, will be removed, thoroughly cleaned, dried, slushed with COMPOUND, rust preventive, heavy, or COMPOUND, rust preventive, light, and stored in a dry protected place. Ventholes will be thoroughly cleaned and filled with COMPOUND, rust preventive, heavy or light. The gas check pad will be removed and cleaned with a wet sponge and wooden scraper, and, after being thoroughly dried, will be coated with OIL, engine, SAE 30. It will then be stored in the sealed container provided. The obturator spindle holes will be filled with COMPOUND, rust preventive, heavy or light.

b. Except for the bore, all bright and unpainted external portions of the carriage will be cleaned with SOLVENT, dry-cleaning, and the surfaces coated with COMPOUND, rust preventive, thin film. This coating can be applied as in painting, using BRUSH, sash-tools, except that in cold weather it should be applied by stippling, i.e., light tapping, with the brush held perpendicular to the surface to be covered. All bright and unpainted surfaces of the tube and breech mechanism should be cleaned with SOLVENT, dry-cleaning. After cleaning, coat the bore with COMPOUND, rust preventive, heavy or light.

c. All painted surfaces should be carefully examined. Particular care should be given to painting and touching up operations to obtain the maximum of protection against rust, erosion, etc. The protective coating of paint prevents the materiel from deteriorating rapidly.

d. Ammunition trucks are to be stored at the emplacements. To preserve the tires, place wooden blocks of sufficient height under the axle and rear of the truck to raise the wheels off the floor or turn them upside down.

**12-INCH SEACOAST MATERIEL**

**32. SERVICE OF MORTAR AND CARRIAGE DURING INACTIVITY.**

a. At intervals not to exceed 6 days, all coated surfaces will be examined, cleaned and recoated where the rust preventive compound has come off. Also the carriage should be traversed about 30 degrees from its former position to prevent the rollers from rusting at bearing surfaces. Immediately after rain or snow, all surfaces should be carefully examined and recoated where necessary.

b. At regular intervals of 30 days or less, the amount of oil in the recoil cylinders should be checked and oil added, if necessary. The carriages should be maneuvered throughout their complete range of azimuth and elevation. The carriage should be left intraverse about 30 degrees from its former position.

c. It is especially required that all parts of the carriage be kept clean at all times. Rust should not be allowed to accumulate on piston rods or bearing surfaces and this requires particular attention. The use of sandpaper or CLOTH, emery, for the purpose of removing rust, etc., is forbidden. The rust may be softened, if necessary, with SOLVENT, dry-cleaning, and removed with CLOTH, crocus.

**33. SERVICING MATERIALS.**

a. The following materials are commonly required for servicing the mortar. A more complete list of materials required for care and preservation and detailed particulars regarding their composition, application, and use is given in TM 9-850.

**b. Table of Lubricants.**

<b>Lubricant</b>	<b>When used</b>	<b>Purpose</b>
GREASE, O.D., No. 00	Below 32 F	Used in the compression grease cups for the cross head trunnion bearings.
GREASE, O.D., No. 0	Above 32 F	
OIL, engine, SAE 10	Below 32 F	Used on cross head guides of the recoil mechanism, breech and firing mechanisms, elevating and traversing mechanisms, etc.
OIL, engine, SAE 30	Above 32 F	

**NOTE:** OIL, lubricating, chain and wire rope, is used to protect the dragline hoist, chains, etc.

OIL, engine, seasonal grade, is a name used to refer to either grade of engine oil.

**CARE AND PRESERVATION****c. Cleaning Materials.**

**CLOTH**, crocus  
**PAPER**, flint, No. 00  
**PAPER**, flint, No. ½  
**PAPER**, flint, No. 1  
**PAPER**, flint, No. 2  
**PATCHES**, cut (canton flannel)  
**POLISH**, metal, paste  
**REMOVER**, paint and varnish  
**SODA**, caustic (lye), for cleaning purposes  
**SOLVENT**, dry-cleaning  
**SPONGE**, (natural)  
**WASTE**, cotton, colored  
**WASTE**, cotton, white

(1) **PAPER**, flint, is issued for use on woodwork such as rammer handles and armament chests. Do not use it on metal surfaces.

(2) **SODA**, caustic(lye), is issued and used for cleaning purposes, and in the preparation of paint removers.

(3) **SPONGE** (natural), is used for washing and cleaning materiel. It may be replaced by **SPONGE**, cellulose, No. 4, No. 6, No. 8 and No. 10. **SPONGE**, cellulose, must not be wrung. Squeezing is the proper method.

(4) **WASTE**, cotton (two grades, colored and white), is used for general cleaning purposes.

(a) **WASTE**, cotton, colored, is used on the exteriors of ordnance materiel. It is also used as calking for cracks from which it is desired to exclude dust and dirt.

(b) **WASTE**, cotton, white, is used on finished surfaces of ordnance materiel. If no **WASTE**, cotton, white, is on hand, an equivalent amount of clean wiping cloths may be used.

**d. Preserving Materiels.** During both active and inactive seasons, the lubricating oils and greases serve as preservatives as well as lubricants. Therefore, thorough lubrication is doubly important. **COMPOUND**, rust preventive, light, and **COMPOUND**, rust preventive, heavy, are used to protect exposed finished surfaces of parts in storage and of the mortar during inactive periods.

**e. Recoil Oil.** **OIL**, recoil, light, will be used in the recoil cylinders.

12-INCH SEACOAST MATERIEL

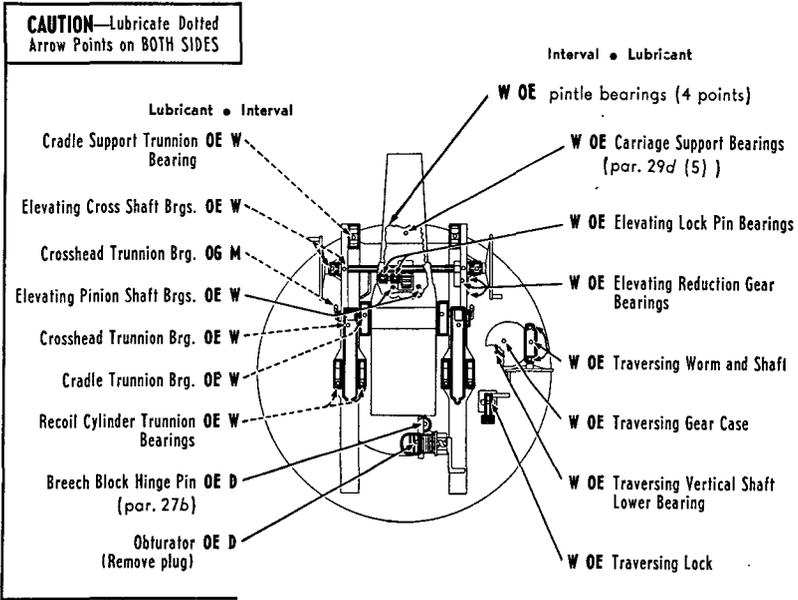

**NOTE**—Lubricate Points Below from inside of Pit

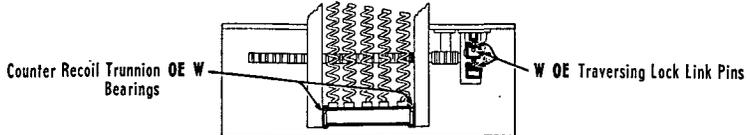

**KEY**

LUBRICANTS	
OE—OIL, Engine	OG—GREASE, O.D.
SAE 30 (above +32°)	No. 0 (above +32°)
SAE 10 (below +32°)	No. 00 (below +32°)

INTERVALS
D—DAILY
W—WEEKLY
M—MONTHLY

RA PD 38883

Figure 38—Lubrication Guide

CARE AND PRESERVATION

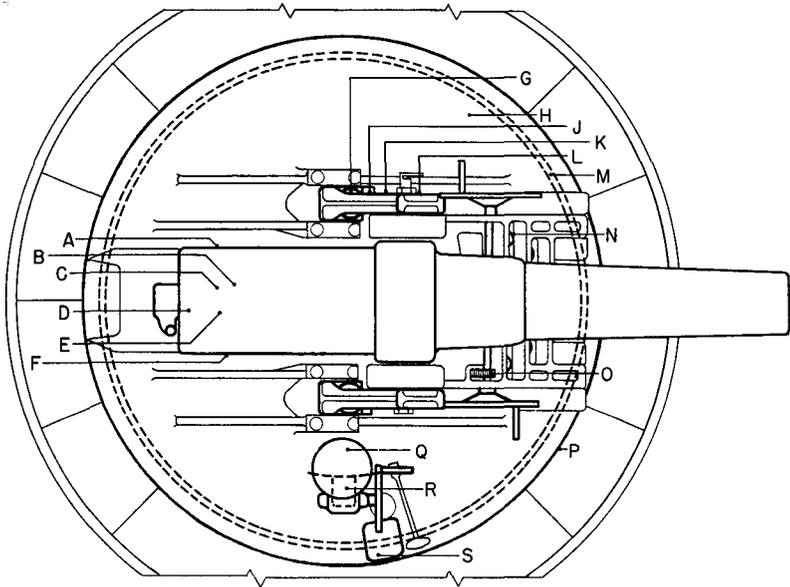

- A-CHAIN FOR REMOVING FIRING PLUG-FUNCTION
  - B-GAS CHECK SEAT - CONDITION
  - C-BORE-EROSION
  - D-FIRING MECHANISM-FUNCTION
    - BREECHBLOCK - CONDITION
    - OBTURATOR SPINDLE-CONDITION
  - E-
    - SPLIT RINGS - CONDITION
    - GAS CHECK PAD - TORN COVERING-RESILIENCY
  - F-LANYARD SAFETY DEVICE - FUNCTION
  - G-RECOIL CYLINDERS - FILLED
  - H-BASE RING -ADJUSTMENT
  - J-PISTON ROD -ADJUSTMENT
  - K-CROSSHEAD GUIDES- LUBRICATION
  - L-ELEVATION QUADRANT -ADJUSTMENT
  - M-PINTLE BEARING -LUBRICATION
  - N-COUNTERRECOIL SPRINGS - ADJUSTMENT
  - O-ELEVATING MECHANISM - FUNCTION
  - P-DUST GUARD - FUNCTION
  - Q-TRAVERSING MECHANISM - FUNCTION
  - R-RECEPTACLE BOX - WATERTIGHT COVER IN PLACE
  - S-AZIMUTH POINTER -FUNCTION
- NOTE - FOR INSPECTION OF ELECTRICAL PARTS SEE TEXT.

RA PD 10748

Figure 39—Inspection Chart

12-INCH SEACOAST MATERIEL

Section VII

INSPECTION AND ADJUSTMENT

	Paragraph
General .....	34
Mortar tube .....	35
Breech mechanism .....	36
Firing mechanism .....	37
Base ring .....	38
Elevating mechanism .....	39
Traversing mechanism .....	40
Recoil and counterrecoil mechanisms .....	41
Electrical equipment .....	42
Lanyard safety device .....	43

34. GENERAL.

a. Inspection has as its purpose the detection of conditions which might cause improper performance. Such conditions may be caused by:

- (1) Mechanical deficiencies resulting from ordinary wear, breakage, etc.
- (2) Faulty or careless operation.
- (3) Improper care (servicing, lubrication, etc.).

Inspection should always be accompanied by corrective measures to remedy any deficiencies found. When properly carried out, inspection and necessary corrective maintenance will insure the maximum reliability and performance of the materiel. The following inspection should be made at regular intervals not to exceed 30 days during both active and inactive seasons.

b. Before inspecting particular points, the mortar and carriage should be inspected in general for evidences of faulty operation, care, and maintenance. Any unusual conditions which might result in improper operation or damage to the materiel will be immediately remedied. Untidy appearance and evidences of rust or deterioration will be corrected. Missing or broken apparatus will be replaced.

35. MORTAR TUBE.

Inspection

a. **Bore.** Note condition of the bore. Look for rust on the lands and carbon deposits in the grooves.

Adjustment

Remove rust or carbon deposits. Clean and slush. Wipe dry and lubricate.

## INSPECTION AND ADJUSTMENT

### Inspection

b. **Gas Check Pad Seat.** Examine the gas check pad seat for burs or roughness.

### Adjustment

Remove burs or roughness, with CLOTH, crocus. If the surface cannot be smoothed in this manner, notify ordnance maintenance personnel. Do not use any other abrasive.

## 36. BREECH MECHANISM.

### Inspection

a. **Operation.** Note smoothness of operation of the breech mechanism in opening and closing.

### Adjustment

If the mechanism binds or does not operate smoothly, disassemble, clean, examine the parts for wear or breakage, and replace unserviceable parts. Lubricate the mechanism and reassemble. If it is still difficult to operate, notify ordnance maintenance personnel.

b. **Rotating Crank Lock.** Note function of rotating crank lock. The lock should release completely with a direct pull to the rear. The lock is released completely when the rotating crank is free to turn. Note that when the breechblock is brought to full closed position, i.e., the faceplate is against the lower stop, the rotating crank snaps into its seat, thereby locking the rotating mechanism from turning in either direction.

Lubricate the mechanism. If it still fails to operate, notify ordnance maintenance personnel.

c. **Rotating Mechanism.** Note smoothness of operation of the rotating mechanism. That is, rotating crank, rotating crank gear, rotating pinion, rotating gear and crank. These gears should mesh so smoothly that the breechblock may be rotated fully and very rapidly. Examine the gears for burs, rust or broken teeth.

Lubricate the mechanism. If it still fails to operate, notify ordnance maintenance personnel.

## 12-INCH SEACOAST MATERIEL

**Inspection****d. Translating Mechanism.**

Note smoothness of operation of the translating mechanism. Examine the translating roller for burs or bruises in the grooves. Note that the translating roller is free in and removable from its seat when the breechblock is locked fully home.

**e. Tray Latch Catch.** Note operation of the tray latch catch. It should not be possible to release the tray latch until the translating roller has been withdrawn far enough to uncover the tray spring bolt. The tray latch is then released with a quick upward jerk.

**f. Tray Back Latch.** Note function of the tray back latch. Rotate and translate the breechblock back onto tray. Swing the breechblock and tray to full open position. Note that the tray back latch engages in the tray back latch catch and holds the breech mechanism firmly in this position. Note that the tray back latch trips readily and releases the breech mechanism when the tray back latch handle is raised.

**g. Breechblock and Breech Recess.** Examine the breechblock and breech recess for burs or indentations on the threads, and for rust, pitting, and other evidences of erosion.

**h. Obturator.** Examine the obturator spindle for burs.

**Adjustment**

If the mechanism binds or does not operate smoothly, disassemble, clean, examine the parts for wear or breakage, and replace unserviceable parts. Lubricate the mechanism and reassemble. If it is still difficult to operate, notify ordnance maintenance personnel.

If the mechanism binds or does not operate smoothly, disassemble, clean, examine the parts for wear or breakage, and replace unserviceable parts. Lubricate the mechanism and reassemble. If it is still difficult to operate, notify ordnance maintenance personnel.

If the mechanism binds or does not operate smoothly, disassemble, clean, examine the parts for wear or breakage, and replace unserviceable parts. Lubricate the mechanism and reassemble. If it is still difficult to operate, notify ordnance maintenance personnel.

If not possible to smooth up or clean with CLOTH, crocus, notify ordnance maintenance personnel. Do not use any other abrasive.

If possible, smooth the spindle, using CLOTH, crocus; if not possible, notify ordnance maintenance personnel.

## INSPECTION AND ADJUSTMENT

### Inspection

**i. Obturator Spindle Washer.** Note that these washers are assembled alternately, beginning with a brass washer in front followed by a steel washer, then another brass washer and finally a second steel washer.

**j. Split Rings.** Examine the split rings for burrs or cracks.

**k. Gas Check Pad.** Examine gas check pad for bruises or torn covering.

### Adjustment

If not assembled in this order, reassemble properly.

Replace defective rings.

Replace defective pad.

## 37. FIRING MECHANISM.

### Inspection

**a.** Note the action of the safety bar mechanism when the breech is opened and closed. See that the safety bar slide mechanism functions properly (par. 6 b(7)).

**b.** Make sure the firing leaf is not distorted.

**c.** Check the tension of the firing leaf spring.

**d.** Make sure that accumulations of dirt do not hold the leaf away from the slide.

**e.** Test firing mechanism by firing a friction primer, using the primer flame baffle (par. 63).

### Adjustment

Repair or replace parts of the safety bar slide mechanism which are worn or broken.

Repair, straighten, or replace the firing leaf.

Replace weak or broken spring.

Disassemble and clean dirty mechanism.

If the slide will not close over primer head or if it distorts the primer head, ream out the primer seat.

## 38. BASE RING.

### Inspection

**a.** To test the base ring for levelness, place the bore rest in the muzzle of the mortar. Place the clinometer on the bore rest. Level the mortar and observe the bubble as the mortar is traversed.

### Adjustment

If the maximum error is more than 10 minutes, notify ordnance maintenance personnel.

**12-INCH SEACOAST MATERIEL**

**39. ELEVATING MECHANISM.**

**Inspection**

a. Test the effort required to elevate and depress the mortar.

b. With the mortar resting on the depression stop, the friction of the elevating friction device should be just sufficient to cause slipping of the parts of the elevating gearing when a force of 156 pounds is applied to the elevating handwheel shaft at a point 100 inches from the center of the shaft. The friction may be determined by means of weights or a spring balance.

(1) Another indication of the proper amount of friction is when the combined efforts of two men (one at each handwheel) is just sufficient to cause slipping of the friction device when an attempt is made to depress the mortar below the minimum.

c. Inspect the elevating rack to see that it is firmly attached to the mortar.

d. Examine the pintle bearing for proper lubrication.

**Adjustment**

If extra effort is necessary, lubricate. If this fails to remedy, notify ordnance personnel.

Adjust elevating friction device adjusting nut.

Tighten bolts.

Lubricate, if necessary.

**40. TRAVERSING MECHANISM.**

**Inspection**

a. Test the effort required to traverse the mortar to the left and right with the traversing brake off. The mechanism should function smoothly.

b. Test the effort required to traverse the mortar with the traversing brake on. With the brake on, one man should with difficulty be able to traverse the carriage.

**Adjustment**

Lubricate, if extra effort is required to traverse. If this fails to remedy, notify ordnance maintenance personnel.

If there is too much slippage, tighten the adjusting nut (fig. 18).

## INSPECTION AND ADJUSTMENT

### Inspection

c. Examine traversing rollers, roller paths, and dust guards for rust and other evidences of improper distribution of lubricant.

d. Examine the azimuth pointer to see that it does not bind or rub.

### Adjustment

Lubricate, if necessary.

Adjust tap bolts or replace.

## 41. RECOIL AND COUNTERRECOIL MECHANISM.

### Inspection

a. Check recoil cylinders for proper amount of oil. The oil should stand at the level of the filling holes.

b. Note whether all counter-recoil spring caps bear against the knife edge bearing in the top carriage.

c. See that the cross head guides are clean and well lubricated.

d. Make sure the piston rods are screwed home in the cross heads.

e. Inspect for any leakage of oil around the cylinder heads, where the heads are screwed into the cylinder.

f. Inspect for leakage at stuffing boxes or followers.

### Adjustment

Refill, if necessary.

Adjust loose springs by means of the adjusting nuts.

Clean and lubricate, if necessary.

If loose, notify ordnance maintenance personnel.

Notify ordnance maintenance personnel.

Tighten followers. Care should be taken not to tighten too much, as this produces excessive friction on the rods. One man using the wrench provided is able to tighten the followers sufficiently. Do not use pipe for additional leverage on the wrench as this will shear the threads. If this does not stop leakage, the boxes need repacking. Notify ordnance maintenance personnel.

**12-INCH SEACOAST MATERIEL**

**Inspection**

g. Inspect for leakage at points where equalizing pipes enter the cylinder or at emptying coupling or emptying plug.

**Adjustment**

Insert new gaskets.

**42. ELECTRICAL EQUIPMENT.**

**Inspection**

a. Note condition of exposed cables.

**Adjustment**

Repair frayed insulation by taping. Replace damaged conductors.

b. Note whether or not the watertight covers on the receptacle boxes are properly sealed.

Replace defective gasket.

c. **Lighting Circuit.** Test lighting circuit for functioning by turning on the switch.

Replace lamps, if necessary. If circuit fails to function, notify ordnance maintenance personnel.

**d. Firing Circuit.**

(1) Test firing circuit by firing an electric primer. Be sure to use the primer flame baffle (par. 63).

If firing circuit does not function properly, notify ordnance maintenance personnel.

(2) Test firing plug to see that it is withdrawn freely when the mortar is depressed at 41 degrees.

Adjust firing plug safety chain.

(3) Note condition of contacts inside the plug box.

If broken, notify ordnance maintenance personnel.

(4) Check to see that the spring cover shapes into place when the firing plug is withdrawn.

Replace, if necessary.

**INSPECTION AND ADJUSTMENT****43. LANYARD SAFETY DEVICE.****Inspection**

a. Test the lanyard safety device for functioning. Elevate the mortar to 41 degrees and hook the bridle ring in the bridle ring catch. Now elevate the mortar slowly to 43 degrees; the ring should drop free of the catch while the mortar is being elevated through this arc of 2 degrees. Return the mortar to the loading position and see that the bridle ring catch does not bind or become distorted during this movement.

**Adjustment**

If this device does not function properly, notify ordnance maintenance personnel.

**12-INCH SEACOAST MATERIEL**

**Section VIII**

**REPAIR**

	<b>Paragraph</b>
General .....	44
Broken equalizing pipe .....	45

**44. GENERAL.**

a. Wear, breakage, or damage from enemy fire make necessary the occasional disassembly and repair of various parts of the mortar and mount. This comes under two headings: that which can be performed by the battery personnel with the equipment furnished, and that which must be performed by trained ordnance personnel. In all cases where the nature of the repair, modification, or adjustment is beyond the scope or facilities of the unit, the responsible ordnance service should be informed in order that trained personnel with suitable tools and equipment may be provided, or proper instructions issued.

b. Disassembly, assembly, and such repairs as may be handled by using arms personnel will be undertaken only under the supervision of an officer or the chief mechanic.

**45. BROKEN EQUALIZING PIPE.**

a. In the event that the equalizing pipe becomes damaged by enemy fire or otherwise, the mortar may be kept in action by means of the plugs provided for this purpose. Remove the damaged equalizing pipe and followers, and insert the plugs in the equalizing pipe seats in the cylinders.

Section IX

**AMMUNITION**

	<b>Paragraph</b>
General .....	46
Nomenclature .....	47
Firing tables .....	48
Classification .....	49
Identification .....	50
Care, handling, and preservation .....	51
Authorized rounds .....	52
Preparation for firing .....	53
Projectiles .....	54
Propelling charges .....	55
Fuzes .....	56
Primers .....	57
Packing .....	58
Subcaliber ammunition .....	59
Field report of accidents .....	60

**46. GENERAL.**

a. Ammunition for the 12-inch mortar M1890MI is of the separate loading type. The loading of each complete round into the mortar requires three separate operations: Loading the projectile; loading the propelling charge; inserting the primer. These components are shipped separately. Deck-piercing and high explosive projectiles are used as service ammunition in this mortar. The deck-piercing projectiles are shipped fuzed.

**47. NOMENCLATURE.**

a. Standard nomenclature is used herein in all references to specific items of issue. Its use is mandatory for all purposes of record.

**48. FIRING TABLES.**

a. For applicable firing tables, see the section of this manual entitled "References."

**49. CLASSIFICATION.**

a. The projectiles authorized for use in this mortar are classified as deck-piercing, high explosive, target practice, and dummy. Deck-piercing projectiles are thick-walled shell fitted with a deck-piercing cap and filled with a comparatively small amount of high explosive as a bursting charge. High explosive projectiles are filled with a high explosive bursting

## **12-INCH SEACOAST MATERIEL**

charge. Target practice projectiles are inert cast-iron shot similar in size, shape, and weight to service projectiles. Dummy projectiles consist of a steel and bronze assembly of somewhat similar size, shape and weight to service projectiles; they are designed for training in handling projectiles and loading cannon, and are inert.

### **50. IDENTIFICATION.**

a. **General.** Ammunition, including components, for the 12-inch mortar is identified by its painting and marking (which includes the ammunition lot number). For purposes of record, the standard nomenclature of the item together with its ammunition lot number completely identifies the ammunition. See figures 40 to 52 and the following paragraphs.

b. **Mark, Model, or "M" Designations.** To identify a particular design, a model designation is assigned at the time the item is classified as an adopted type. This "M" designation becomes an essential part of the standard nomenclature and is included in the marking on the item. The present system of model designation consists of the letter M followed by an Arabic numeral. Modifications are indicated by adding the letter A and appropriate Arabic numerals. Thus, M2A1 indicates the first modification of an item for which the original model designation was M2. Prior to the first World War, the year in which the design was adopted, preceded by an M, was used as the model designation, for example: M1890. From the first World War until July 1, 1925, it was the practice to assign mark numbers. The word "Mark" abbreviated "Mk.", was followed by a Roman numeral, for example, SHELL, H. E., Mk. III. The first modification of a model was indicated by the addition of MI to the mark number, the second by MII, etc.

c. **Ammunition Lot Number.** When ammunition is manufactured, an ammunition lot number, which becomes an essential part of the marking, is assigned in accordance with pertinent specifications. This lot number is stamped or marked on every item of ammunition, unless the item is too small, and on all packing containers. It is required for all purposes of record, including reports on condition, functioning, and accidents, in which the ammunition is involved. To provide for the most uniform functioning, all of the components in any one lot are manufactured under as nearly identical conditions as practicable. For example, in the case of projectiles, any one lot consists of projectiles made by one manufacturer, loaded by one manufacturer, and of one weight. Therefore, to obtain the greatest accuracy in firing, successive rounds should consist of projectiles of one lot number, fuzes of one lot number, propelling charges of one lot number, and primers of one lot number, whenever practicable.

## AMMUNITION

### d. Painting and Marking.

(1) **PAINTING.** Ammunition is painted to prevent rust and to provide, by the color, a ready means of identification as to type. Projectiles for the 12-inch mortar are painted as follows:

Deck-piercing and high explosive . . . . .	Yellow; marking in black.
Target practice (inert) . . . . .	Black; marking in white.
Dummy, or drill (inert) . . . . .	Black; marking in white, except band at center of gravity which is red.

**NOTE:** The above color scheme is not wholly in agreement with the basic color scheme described in TM 9-1900, practice projectiles being generally painted blue.

(2) **MARKING.** For purposes of identification, the following is marked on the components of separate loading ammunition.

#### (a) *On the Projectiles:*

Caliber and type of cannon in which fired.

Kind of filler, for example, "TNT," "EXP. D," etc.

Type of projectile and mark or model number. The location of this marking indicates the center of gravity of the loaded and fuzed projectile.

Weight of loaded and fuzed projectile in pounds.

Ammunition lot number.

#### (b) *On the Propelling Charges:*

Designation of section, for example, "BASE ZONE 4" on base section of a base and increment charge.

Type of powder and powder lot number.

Caliber and type of cannon in which fired.

Weight of igniter charge.

On dummy propelling charges: "DUMMY CHARGE" or "DUMMY PROPELLING CHARGE" together with the caliber and model of cannon in which it is used.

#### (c) *On the Fuze (Stamped on the Body):*

Type and model of fuze.

Manufacturer's initials.

Loader's initials.

Month and year loaded.

Loader's lot number.

#### (d) *On the Primer (Stamped in the Metal):*

Initials of loader.

Loader's lot number.

Year of loading.

Mark or model number.

## **12-INCH SEACOAST MATERIEL**

e. **Weight Markings.** It is not practicable to manufacture projectiles within the narrow weight limits required for the desired accuracy of fire. In the case of projectiles for the 12-inch mortar, the actual weight of the projectile, to the nearest pound, is stenciled on the projectile in order that the percentage difference from the nominal weight may be determined and appropriate ballistic corrections may be applied.

### **51. CARE, HANDLING, AND PRESERVATION.**

a. Ammunition and explosives are packed to withstand conditions ordinarily found in the field. Projectiles for this mortar are shipped with a grommet to protect the rotating band. Projectiles with deck-piercing cap or windshield are shipped crated; practice shell, uncrated. Charges and primers are packed in moisture-resistant containers.

b. Since ammunition and explosives are adversely affected by moisture and high temperatures, due consideration should be given to the following:

(1) Moisture-resistant seals should not be broken until ammunition is to be used.

(2) Ammunition, particularly fuzes, primers and propelling charges, should be stored in the original container, in a dry, well-ventilated place protected from sources of high temperatures, including the direct rays of the sun. More uniform firing is obtained if successive rounds are at the same temperature.

c. Do not attempt to disassemble any fuze.

d. Primers must always be stored in a dry place. Prolonged exposure to moisture or dampness may cause malfunctioning.

e. Explosives and ammunition must be handled with appropriate care at all times. The explosive elements in primers and fuzes are particularly sensitive to undue shock and high temperature.

f. Each of the separate loading components should be free of foreign matter—sand, mud, grease, etc.—before loading into the gun.

g. Sealed containers should not be opened until just before use.

h. Components of rounds prepared for firing but not fired will be returned to their original condition and packings and appropriately marked. Such components will be used first in subsequent firings in order that stocks of opened packings may be kept at a minimum.

i. Propelling charges will be gaged for maximum diameter by gages furnished by the Ordnance Department. Charges which do not pass through the gage will not be fired. A charge made up of a single section which contains a core igniter need not be gaged.

AMMUNITION

52. AUTHORIZED ROUNDS.

AUTHORIZED ROUNDS FOR 12-INCH MORTAR M1890MI

Nomenclature of Fuzed Projectile	Fuze Action	Propelling Charge	Primer
<i>SERVICE AMMUNITION:</i>			
SHELL, H.E., 700-lb., Mk. VIII, 12-in. mortar, M1890-90MI-08 <sup>1</sup> , w/FUZE, B.D., Mk. V <i>or</i>	nondelay		
SHELL, H.E., 700-lb., Mk. XI, 12-in. mortar, M1890-90MI-08 <sup>1</sup> , w/FUZE, P.D., M46 <sup>1</sup> , or Mk. III <sup>2</sup> or Mk. IIIA <sup>2</sup> <i>or</i>	S.Q.		
SHELL, H.E., 700-lb., Mk. XI, 12-in. mortar, M1890-90MI-08 <sup>1</sup> , w/FUZE, P.D., M47 <i>or</i>	delay	10 ES, NH pdr. <sup>1</sup> or 10 ES <sup>2</sup>	Elec. <sup>3</sup>
SHELL, H.E., 700-lb., Mk. VI, 12-in. gun, modified for 12-in. mortar, M1890-90MI-08 <sup>2</sup> , w/FUZE, B.D., Mk. V	nondelay	B&I zone 8B-9 <sup>2</sup>	
SHELL, D.P., 700-lb., M1911A, 12-in. mortar, M1890-90MI-08 <sup>1</sup> , w/FUZE, B.D., Mk. X	delay	10 ES, NH pdr. <sup>1</sup> or 10 ES <sup>2</sup> or B&I zone 8B-9 <sup>2</sup>	Elec. <sup>3</sup>
SHELL, D.P., 824-lb., M1898, 12-in. mortar, M1890-90MI-08 <sup>2</sup> , w/FUZE, B.D., Mk. X	delay	10 ES, NH pdr. <sup>1, 6</sup> or 10 ES <sup>2, 6</sup> or Base zone 8A <sup>2</sup>	Elec. <sup>3</sup>
SHELL, D.P., 1,046-lb., Mk. XXVIII, 12-in. mortar, M1890-90MI-08, and M1912, w/FUZE, B.D., Mk. X <i>or</i>	delay	10 ES, NH pdr. <sup>1, 5</sup> or 10 ES <sup>2, 5</sup> or B&I zone 1-7 <sup>2, 4</sup>	Elec. <sup>3</sup>
SHELL, D.P., 1,046-lb., M1898 <sup>2</sup> , 12-in. mortar, M1890-90MI-08, and M1912, w/FUZE, B.D., Mk. X			

B&I—base and increment. 10 ES—ten equal sections.

<sup>1</sup>Standard item. Priority of issue and use to be given to Limited Standard.

<sup>2</sup>Limited Standard, except in references to fuzes, which are Substitute Standard. See Note<sup>1</sup>.

<sup>3</sup>PRIMER, electric, M30 is service standard. In case of power failure PRIMER, friction, M1914, will be used.

<sup>4</sup>Propelling charge arranged with base and two increments: base zone 1, increments 2-3; base zone 2, increments 3-4; etc. to base zone 5, increments 6-7.

<sup>5</sup>Propelling charge as issued contains 10 equal sections. For 1,046-lb shell, the maximum charge is seven sections.

<sup>6</sup>Maximum charge for 824-lb shell, nine sections.

12-INCH SEACOAST MATERIEL

AUTHORIZED ROUNDS FOR 12-INCH MORTAR M1890MI

Nomenclature of Fuzed Projectile	Fuze Action	Propelling Charge	Primer
<b>TARGET PRACTICE AMMUNITION:</b> SHELL, C.I., 700-lb., M1912, 12-in. mortars, M1890-90MI-08, and M1912	none	10 ES, NH pdr. <sup>1</sup> or 10 ES <sup>2</sup> or B&I zone 8E-9 <sup>2</sup>	Elec. <sup>3</sup>
SHELL, C.I., 1,046-lb., M1907 <sup>1</sup> , 12-in. mortar, M1890-90MI-08, and M1912	none	10 ES, NH pdr. <sup>1, 5</sup> or 10 ES <sup>2, 5</sup> or B&I zone 1-7 <sup>2, 4</sup>	Elec. <sup>3</sup>
<b>DRILL AMMUNITION:</b> PROJECTILE, dummy, 700-lb., Mk. I, 12-in. mortar PROJECTILE, dummy, 700-lb., Mk. IAI, 12-in. mortar PROJECTILE, dummy, 1,046-lb., 12-in. mortar	none	SS dummy, 33 or 65-lbs. or 4 section, dummy 8, 16, 20 and 24-lb.	Inert Elec. <sup>3, 7</sup>
<b>SUBCALIBER:</b> SHOT, fixed, solid, 2.95-in. Zone 1, zone 2, or zone 3	none	(fixed ammunition)	

B&I—base and increment. 10 ES—ten equal sections.

<sup>1</sup>Standard item. Priority of issue and use to be given to Limited Standard.

<sup>2</sup>Limited Standard, except in references to fuzes, which are Substitute Standard. See Note<sup>1</sup>.

<sup>3</sup>PRIMER, electric, M30 is service standard. In case of power failure PRIMER, friction, M1914, will be used.

<sup>4</sup>Propelling charge arranged with base and two increments: base zone 1, increments 2-3; base zone 2, increments 3-4; etc. to base zone 5, increments 6-7.

<sup>5</sup>Propelling charge as issued contains 10 equal sections. For 1,046-lb shell, the maximum charge is seven sections.

<sup>6</sup>Maximum charge for 824-lb shell, nine sections.

<sup>7</sup>Live primer furnished with round. Primer to be fired by the service and retained for use with dummy projectile and charge.

53. PREPARATION FOR FIRING.

a. Aside from removal of the packing material (including the grommet which protects the rotating band), the deck-piercing and certain high explosive projectiles for this mortar are ready for firing. Some of the high explosive projectiles must be fuzed, as described in paragraph 54 c. As the practice projectiles are shipped uncrated, it is necessary only to remove the grommet to prepare them for firing.

**AMMUNITION****54. PROJECTILES.**

a. **General.** Although of the same general shape—cylindrical body and ogival head—projectiles for the 12-inch mortar, M1890MI, differ in characteristic details as follows (figs. 40 to 44):

- (1) Location of fuze: base for penetration, point for surface effect.
- (2) Radius of ogive: short for old design and long for new design projectiles.
- (3) Rotating band: narrow for old design and wide for new design projectiles.
- (4) Armor-piercing cap: used only with projectiles designed to pierce hull or deck armor.
- (5) Windshield or false ogive: used where required for improved ballistics.

12-INCH SEACOAST MATERIEL

b. Table of Data.

Projectile		Length in.	Weight lb.	Shape		Fuze		Rotating Band in.	Filler		Shipped
Type	Model			Point	Base	Model	Action		Weight lb.	Type	
H.E. 700-lb.	Mk. VIII	46.7	700	long ogive	square	Mk. V	nondelay	2	87.57	D	fuzed, crated
H.E. 700-lb.	Mk. XI	50.7	712	long ogive	square	M46 or Mk. III M47	S.Q. delay	2	118.25	TNT	unfuzed; crated or uncrated
H.E. 700-lb.	Mk. VI	45.0	696	ogive	square	Mk. V	nondelay	4 (cut)	86.40	D	fuzed, crated
D.P. 700-lb.	M1911A	38.4	700	long ogive	square	Mk. X	delay	2	24.16	D	fuzed, crated
D.P. 824-lb.	M1898	37.1	824	D.P. cap	square	Mk. X	delay	1.25	32.68	D	fuzed, crated
D.P. 1,046-lb.	Mk. XXVIII	49.3	1,046	D.P. cap	square	Mk. X	delay	1.25	58.52	D	fuzed, crated
D.P. 1,046-lb.	M1898	49.2	1,046	D.P. cap	square	Mk. X	delay	1.25	58.35	D	fuzed, crated
C.I. 700-lb.	M1912	38.4	700	long ogive	square	—	—	2	—	—	ready to fire
C.I. 1,046-lb.	M1907	49.7	1,046	D.P. cap	square	—	—	1.27	—	—	ready to fire
Dummy 700-lb.	Mk. I	45.0	700	ogive	square	—	—	3.26 ring	—	—	crated
Dummy 700-lb.	Mk. IA1	45.0	675	ogive	square	—	—	3.26 ring	—	—	crated
Dummy 1,046-lb.	—	49.16	1,022	D.P. cap	square	—	—	3.26 ring	—	—	crated
Shot, fixed	2.95-in.	17.4 C.I. 16.6 Steel	18	short ogive	square	—	—	.56	—	—	4/box

AMMUNITION

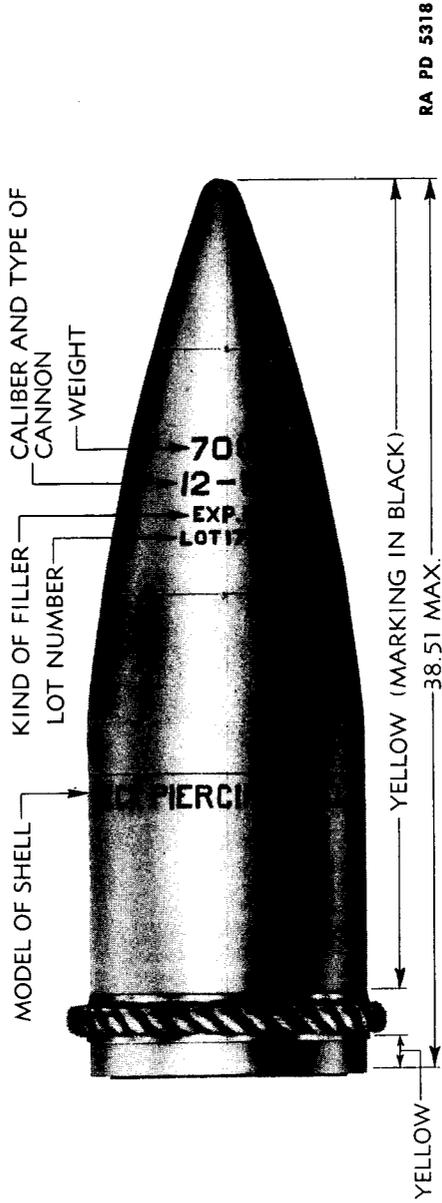
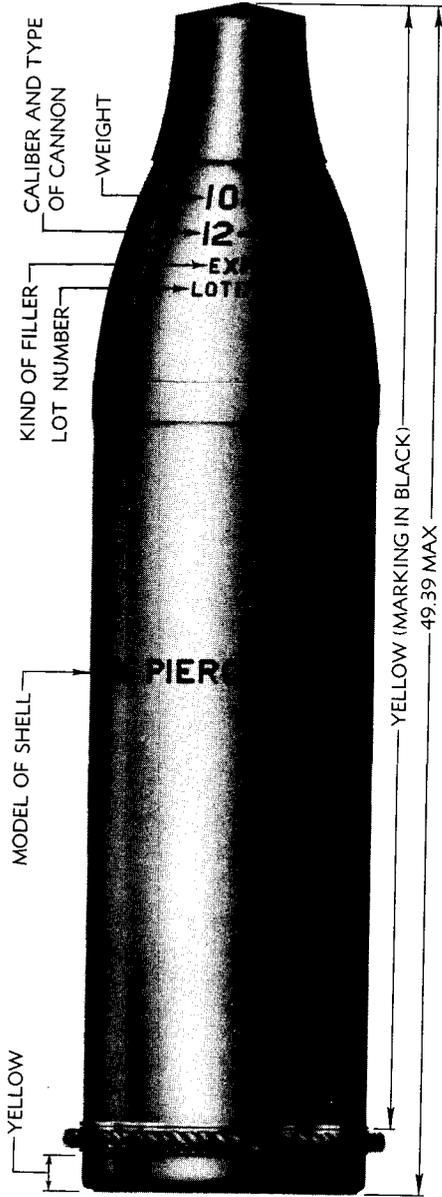

Figure 40—SHELL, D.P., 700-lb., M1911A, 12-inch mortar

12-INCH SEACOAST MATERIEL



RA PD 5319

Figure 41—SHELL, D.P., 1,046-lb., MK. XXVIII, 12-inch mortar

AMMUNITION

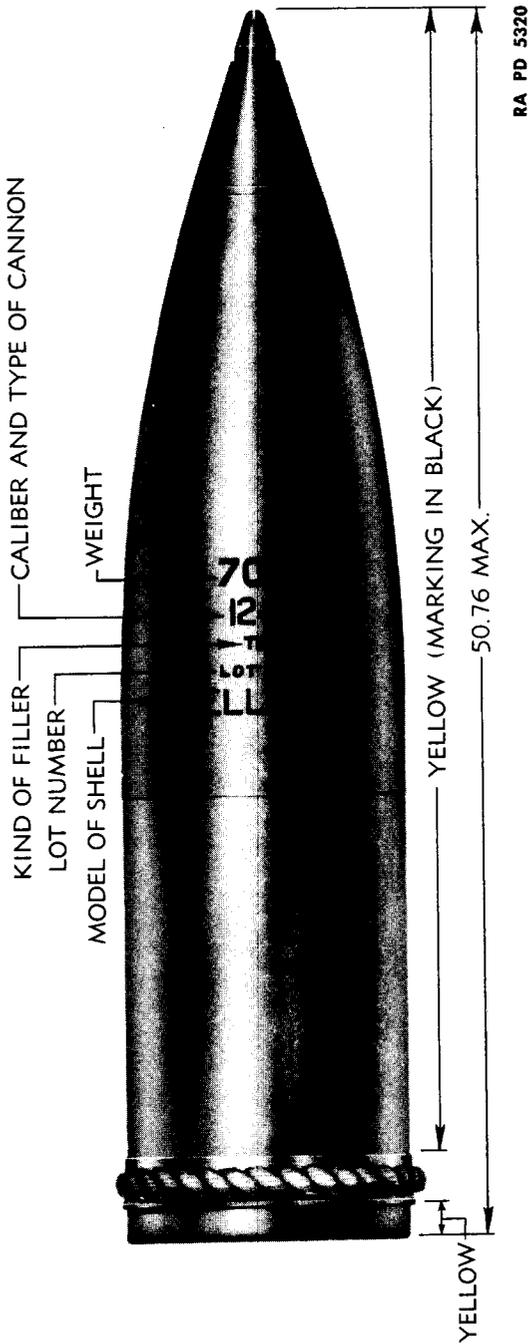

Figure 42 — SHELL, H.E., 700-lb., MK. XI, 12-inch mortar, M1890-90 MI-08

12-INCH SEACOAST MATERIEL

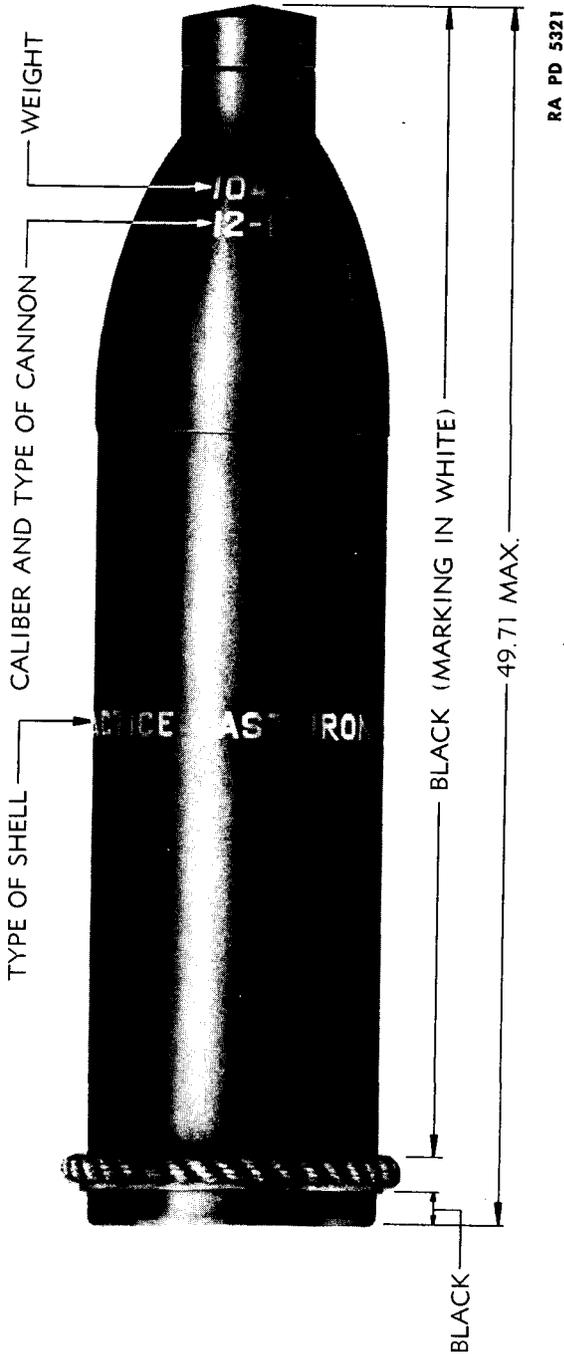

Figure 43—SHELL, C.I., 1,046-lb., M1907, 12-inch mortar

AMMUNITION

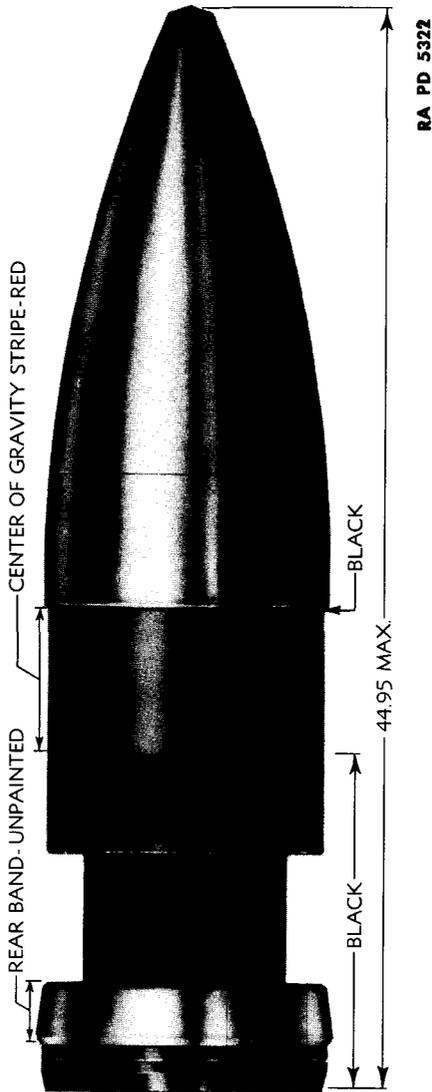

Figure 44 -- PROJECTILE, dummy, 700-lb., MK. IA1, 12-inch mortar

**12-INCH SEACOAST MATERIEL**

**c. Preparation for Firing.**

(1) Service projectiles shipped fuzed and target practice projectiles need only to have the packings (grommet and crate) removed to be ready for firing.

(2) Service projectiles shipped unfuzed are prepared for firing as follows:

(a) Remove packings (grommet and crate) from shell.

(b) Unseal and remove fuze from its packings.

(c) Remove windshield and fuze hole plug.

(d) Examine fuze cavity to be sure that cavity and threads are free of foreign material.

(e) Place felt washer in place and screw in fuze by hand, then tighten with a fuze wrench.

(f) **NOTE:** In the case of the Mk. III or Mk. IIIA fuze, remove the waterproof tape from the fuze and remove the cap from the windshield of the shell; the cap must not be used on the windshield when these fuzes are used.

(g) Replace the windshield.

(3) Shell prepared for firing but not fired will be unfuzed before return to storage. This may be done by reversing the steps in (2) above.

**55. PROPELLING CHARGES.**

**a. General.** The propelling charge consists of a measured quantity of smokeless powder and an igniter of black powder. The charge is divided into sections, each in a cloth bag. Dependent upon the relative size of the sections, the propelling charge is classified as equal section or base and increment. Propelling charges are packed in airtight cartridge storage cases and, to prevent accidental ignition of the charge, an igniter protector cap is placed on each end of each charge and on the top section in the case.

**b. Equal Section.** This type of charge (fig. 45) is divided into 10 equal parts of approximately 6.3 pounds of NH or NC powder, each in its own bag. The igniter is placed in a separate bag to which are attached four straps which serve to hold the sections together. The smokeless powder bags are undyed and the igniter bag is dyed red for the double purpose of indicating the presence of black powder and indicating that end of the charge which must be to the rear (against the breechblock) when the charge is loaded into the mortar. The complete charge is approximately 20 inches in length and 12.25 inches in diameter. It is marked as follows:

**AMMUNITION**

**Base Section—Igniter (dyed red)**

12 OZ. A1  
 BLK. PDR. LOT  
 IGNITER  
 12 IN. MORTAR  
 M1890 & M1908  
 MAR. 1937

**Top of Each Section**

WT. 1/10 CHG. 6.3 LBS  
 ALIQUOT PART  
 12 IN. MORTAR  
 M1890 & 1908  
 LOT 123-4-37

**c. Base and Increment.** This type of charge (fig. 46) is divided into a base charge and several increments which, generally, are smaller than the base. The base charge is assembled in a bag which also contains a 12-ounce igniter charge divided into three parts: 4 ounces in a pad on each end and 4 ounces in an axial cloth tube connecting the end pads. In charges of current manufacture the cloth of the igniter pad is dyed red; in older charges, the cloth is undyed, but is stenciled with the words **IGNITING POWDER**. This type of charge is assembled in the same manner as the equal section type; four straps, sewed to the base section, serve to hold the charge together. The various base sections and increment sections of this type charge are shown below:

	Diam. (in.)	Length (in.)	Wt. of powder (lb) (oz)	
Base zone 1 . . . . .	9.125	12.125	19	0
Base zone 2 . . . . .	9.125	12.375	22	0
Base zone 3 . . . . .	9.375	12.625	25	6
Base zone 4 . . . . .	10.0	12.875	29	4
Base zone 5 . . . . .	10.625	13.25	35	0
Base zone 8A . . . . .	12.25	19.0	59	10
Base zone 8B . . . . .	12.25	16.	53	14.4
Increment zone 2 . . . . .	9.125	1.75	3	0
Increment zone 3 . . . . .	9.125	2.0	3	6
Increment zone 4 . . . . .	9.375	2.125	3	14
Increment zone 5 . . . . .	10.0	2.5	5	12
Increment zone 6 . . . . .	10.625	3.25	7	2
Increment zone 7 . . . . .	10.625	4.25	8	6
Increment zone 9 . . . . .	12.25	3.75	12	6.4

The ends of the base section are quilted and marked with the words **IGNITING POWDER**. The sides are marked in large numerals with the zone of the section and, in smaller characters, with the lot number of the powder. The increment is marked on the side with the zone number of the increment and, on the ends, with the lot number of the powder.

**d. Preparation for Firing.** To prepare a charge for firing, the charge is removed from the cartridge storage case and igniter protector caps are removed. In the case of the equal section charge, excess sections are removed and the straps retied. In the case of the base and increment

12-INCH SEACOAST MATERIEL

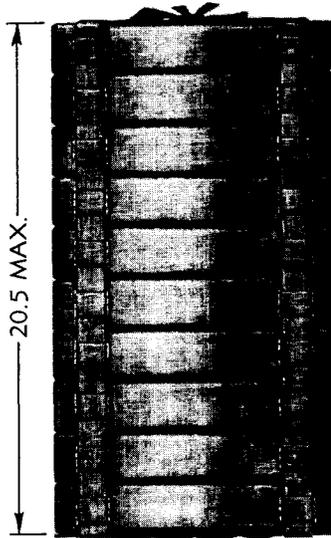

RA PD 5323

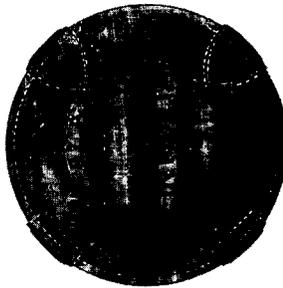
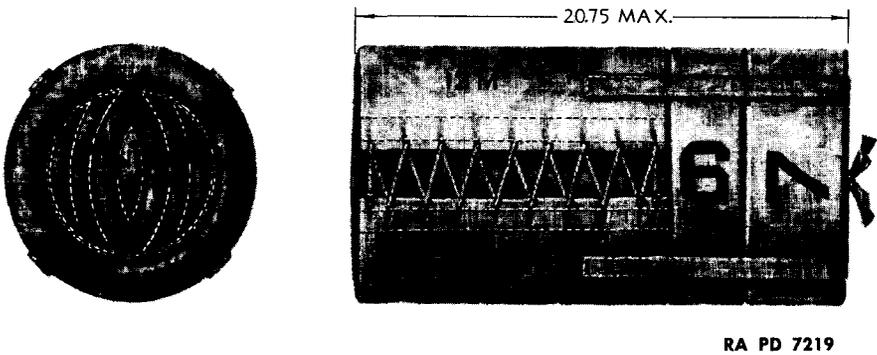

*Figure 45—CHARGE, propelling, 10 equal section, NH powder, 12-inch mortar, M1890-90MI-08*

**AMMUNITION**

type, an appropriate base section and one or two increments are assembled and tied together. (For instance, zone 5 may be fired in three different ways: Base zone 5, alone; Base zone 4 and increment 5; Base zone 3 and increments 4 and 5.) The charge is gaged and if it passes the gage, it is ready for firing. **NOTE:** A charge consisting of base section only need not be gaged.

e. **Dummy Charges.** Dummy propelling charges are provided for training. These charges consist of wood and lead cylinders, resembling powder grains, assembled, in strong cloth bags. Two types are provided: One is a single section charge weighing 33 or 65 pounds (fig. 47); the other represents an aliquot part charge, and may be used, any section alone or any combination of sections tied together, to simulate service charges. The sections weigh respectively, 8, 16, 20 and 24 pounds.



RA PD 7219

**Figure 46—CHARGE, propelling, base and increments, zone 5-6-7, 12-inch mortars, M1890-90MI-08, 1,046-lb., proj.**

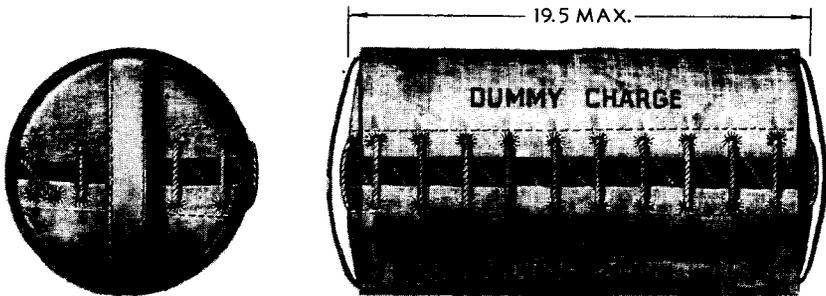

RA PD 7220

**Figure 47—CHARGE, propelling, dummy, single section, 65-lb., M1917, 12-inch mortar**

**12-INCH SEACOAST MATERIEL****56. FUZES.**

a. **Classification.** A fuze is a mechanical device used with a projectile to explode it at the time or under the circumstances desired. Fuzes are classified in general, according to position, as point-detonating or base-detonating. Fuzes authorized for use with projectiles for the MORTAR, 12-inch, M1890MI, are classified further (as to type of action after impact) as superquick, nondelay, and delay.

b. **Arming.** Artillery impact fuzes are so designed that they are in an unarmed condition before firing; they become armed by forces incident to firing.

c. **Boresafe.** Dependent upon the method of arming, some fuzes are considered boresafe. A boresafe fuze is one in which the explosive train is so interrupted that prior to firing, and while the projectile is still in the bore of the cannon, premature action of the bursting charge is prevented should any of the more sensitive elements malfunction.

d. **FUZE, B.D., Mk. X.** This base-detonating fuze (a boresafe type) is used with major caliber deck-piercing projectiles. As issued, the fuze is assembled to the projectile and covered by the base cover, hence is not visible. This fuze provides a delay action.

e. **FUZE, B.D., Mk. V.** This base-detonating fuze is used with high explosive projectiles in which nondelay action is required. It is classified as boresafe. As issued, this fuze is assembled to the projectile and covered by the base cover, hence is not visible.

f. **FUZE, P.D., M46.** This point-detonating fuze (fig. 48) is of the superquick type designed for use with high explosive projectiles. Although this fuze is not classified as boresafe, it may be fired under the same conditions as boresafe fuzes. It may be identified by the stamping on the body and the white paint on the head.

g. **FUZE, P.D., Mk. III and Mk. IIIA.** Those fuzes (each with and without interrupter) are used in place of FUZE, P.D., M46, when the latter is not available. They are nonboresafe. When these fuzes are used, the cap of the false ogive is omitted when replacing the windshield after assembling the fuze to the shell. The fuzes are identified by the marking on the container and stamping on the body of the fuze.

h. **FUZE, P.D., M47.** This point-detonating fuze (fig. 49) is of the delay type used with high explosive projectiles. Although this fuze is not classified as boresafe, it may be fired under the same conditions as boresafe fuzes. It may be identified by the stamping on the body and the black paint on the head.

AMMUNITION

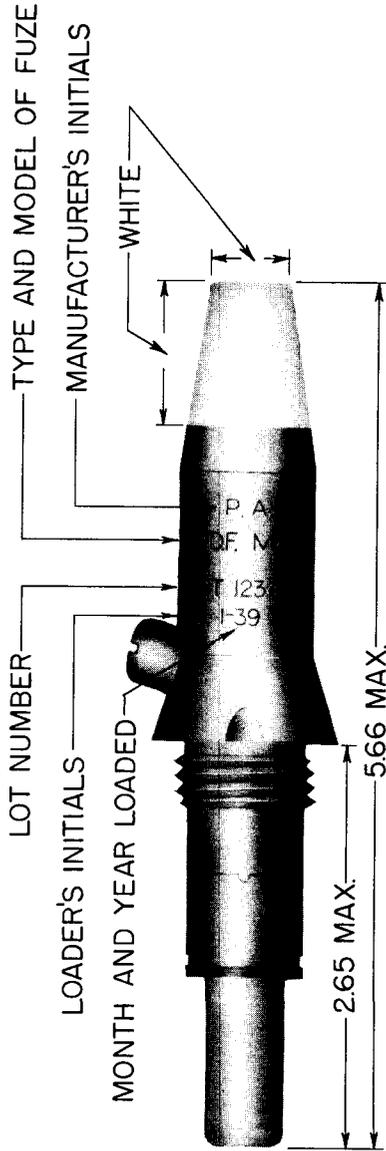

RA PD 1277

Figure 48—FUZE, P.D., M46

12-INCH SEACOAST MATERIEL

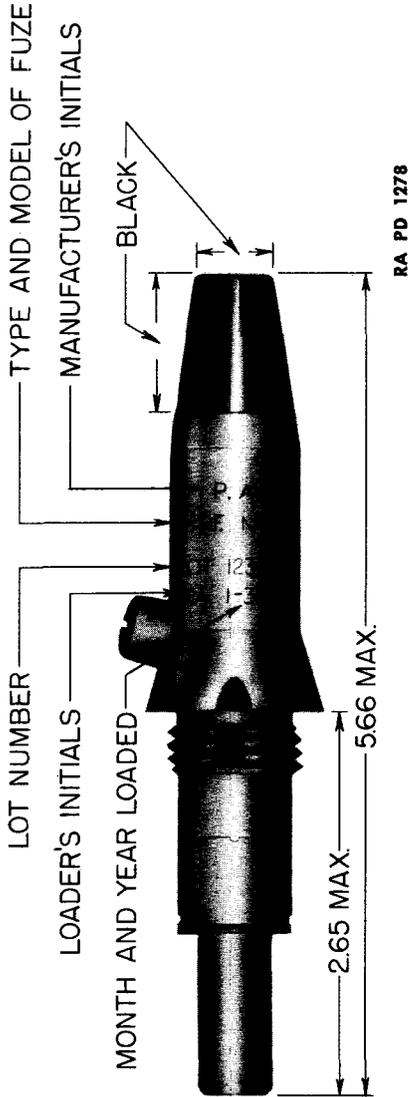

Figure 49 --FUZE, P.D., M47

## AMMUNITION

### 57. PRIMERS.

#### a. General.

(1) The primer is the component used to initiate the combustion of the propelling charge. It consists, essentially, of a small quantity of sensitive explosive and a larger quantity of black powder contained in a brass container. The primer is designed for insertion into the breech-block and, dependent upon the type, is fired by an electric current or by friction. The symbol of the loader and the lot number of the primer are stamped on the head.

(2) Primers should be carefully examined and tested before any attempt is made to use them. All primers should be tested in the firing mechanism of the mortar with which they will be used to check proper fit. In addition, electric primers should be tested for proper resistance, if the equipment is available.

**b. PRIMER, electric, M30.** This primer (fig. 50) is used with all mortars in emplacements fitted with electrical equipment. It is fired by the heat generated by an electric current passing through a resistance wire embedded in the sensitive explosive. The black powder charge intensifies and transmits the flame to the igniter which is sewed to the propelling charge. This primer may be distinguished from the friction primer, described below, by the presence of black insulation on the wire and the presence of a groove around the head of the case. A live primer is supplied for dummy rounds; it is to be fired by the service and retained for use with the dummy (drill) ammunition.

**c. PRIMER, friction, M1914.** This primer (fig. 51) is similar in appearance to the electric primer, described in subparagraph **b** above, with the exceptions stated. It is used for all 12-inch mortars where electric power is not available either from lack of facilities or from temporary power failure. It is ignited by the heat generated when a serrated plug is pulled through a friction mixture.

### 58. PACKING.

**a. General.** Complete data covering dimensions, volume, and weight, of various components of the ammunition described herein are published in SNL P-3, SNL P-4, SNL P-6, SNL P-7, and SNL P-8. Some types of projectiles for this mortar are shipped uncrated, fitted with a rope grommet; other types are fitted with grommet and packed one per crate. Although weights of individual projectiles vary somewhat, dependent upon type and model (likewise, propelling charges, dependent upon the particular powder charge), the following data are representative for estimating weight and volume requirements:

12-INCH SEACOAST MATERIEL

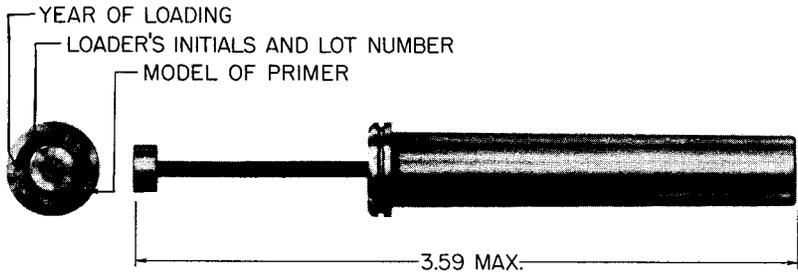

RA PD 4505

Figure 50—PRIMER, electric, M30

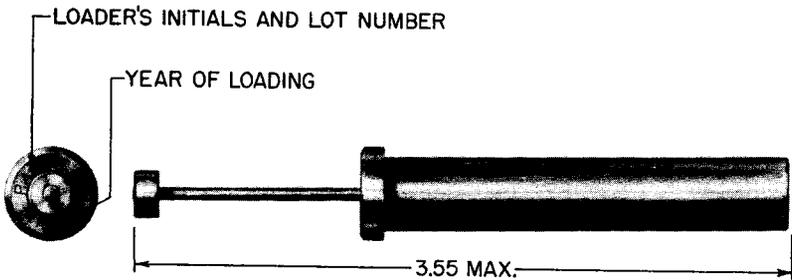

RA PD 4539

Figure 51—PRIMER, friction, M1914

(1) 12-INCH MORTAR PROJECTILES AS SHIPPED.

	Weight (lb)	Volume (cu. ft)
Deck-piercing (700-lb): Packed, one per crate	739	7.34
Over-all dimensions (in.): 44 <sup>9</sup> / <sub>16</sub> by 16 <sup>7</sup> / <sub>8</sub> by 16 <sup>7</sup> / <sub>8</sub>		
Deck-piercing (824-lb): Packed, one per crate	864	6.98
Over-all dimensions (in.): 43 <sup>5</sup> / <sub>8</sub> by 16 <sup>5</sup> / <sub>8</sub> by 16 <sup>5</sup> / <sub>8</sub>		
Deck-piercing (1,046-lb): Packed, one per crate	1,093	8.86
Over-all dimensions (in.): 55 <sup>1</sup> / <sub>16</sub> by 16 <sup>9</sup> / <sub>16</sub> by 16 <sup>9</sup> / <sub>16</sub>		
Practice (700-lb): Uncrated	700	4.10
Over-all dimensions (in.): 38.08 by 13.64 (diam.)		
Practice (1,046-lb): Uncrated	1,046	5.36
Over-all dimensions (in.): 49.31 by 13.70 (diam.)		

**AMMUNITION**

	Weight (lb)	Volume (cu. ft)
<b>(2) PROPELLING CHARGES AS SHIPPED*</b>		
Example: 1½ charges of 10 E. S. propelling charges: Packed in cartridge storage case . . . . .	155	5.47
Over-all dimensions (in.):		
41 <sup>5</sup> / <sub>8</sub> by 15 <sup>1</sup> / <sub>8</sub> (diam.)		
<b>FUZE, P.D., M46: Packed 50 per metal lined box . . . . .</b>	<b>52.2</b>	<b>.86</b>
Over-all dimensions (in.):		
18 <sup>3</sup> / <sub>16</sub> by 9 <sup>3</sup> / <sub>16</sub> by 8 <sup>3</sup> / <sub>16</sub>		
<b>PRIMER, electric, M30: Packed 20 per can, 25 cans (500 primers) per box . . . . .</b>	<b>43</b>	<b>.90</b>
Over-all dimensions (in.):		
16.65 by 16.025 by 5.825		

**b. Marking.** In addition to the marking for identification described in paragraph 50, containers are marked with the shipping name of the item, addresses of consignor and consignee, shipping ticket numbers, the weight and volume of the package, and insignia indicating ownership by the Government, the War Department and the Ordnance Department.

**59. SUBCALIBER AMMUNITION.**

**a. General.** Ammunition authorized for subcaliber practice with this mortar is issued in the form of fixed complete rounds. The term "fixed" used in connection with ammunition, refers to complete rounds in which the propelling charge is fixed (not adjustable) and which are loaded into the gun as a unit. The round consists of a projectile, a brass cartridge case, propelling charge, and primer. The cartridge case contains the primer (pressed in the head) and the loosely assembled smokeless powder propelling charge. The projectile is a solid steel or cast-iron ogival shot to which the neck of the cartridge case is rigidly crimped. The rim around the head of the cartridge case is used for extracting the case from the gun. The primer is of the igniting type designed to be ignited by the flame from the service primer which is fired in the breech mechanism of the mortar. The igniting primer of the subcaliber round, used in this mortar, contains a charge of 100 grains of black powder.

**b. Rounds.** Subcaliber rounds for this gun are designated SHOT, fixed, solid, subcaliber, 2.95-inch, zone (1, 2, or 3). They are approximately 17 inches in length and weigh approximately 20 pounds. The propelling charge varies from approximately ¼ to ⅜ pound according

\* No wooden shipping cover is required for domestic shipment when the cartridge storage case (C.S.C.) is modified with a protecting rim. For oversea shipments, a wooden crate is required.

12-INCH SEACOAST MATERIEL

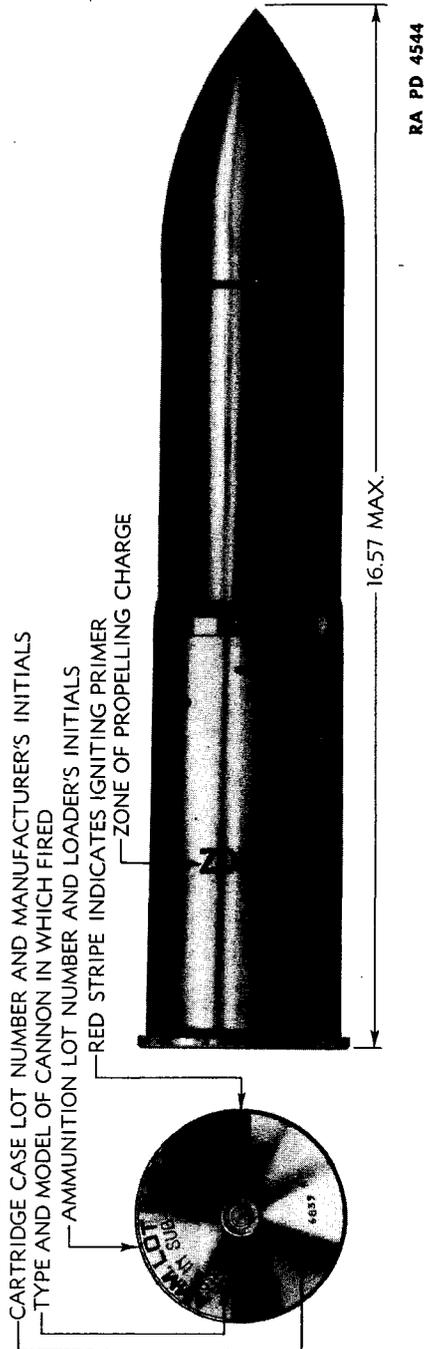

Figure 52—SHOT, fixed, solid, subcaliber, 2.95-inch, zone 1

### AMMUNITION

to the zone for which the round is designated. The word "ZONE" and the appropriate number are stenciled on the side of the cartridge case.

c. **Packing.** Subcaliber rounds for this mortar are packed in individual fiber container, M49, 4 containers (4 rounds) per box: Weight, 102 pounds (zone 3): volume, 1.21 cubic feet; over-all dimension,  $23\frac{1}{2}$  by  $9\frac{7}{8}$  by  $9\frac{7}{8}$  inches.

### 60. FIELD REPORT OF ACCIDENTS.

a. Any serious malfunctions of ammunition must be promptly reported to the ordnance officer under whose supervision the ammunition is maintained or issued (AR 45-30, par. 7).

12-INCH SEACOAST MATERIEL

Section X

ORGANIZATION SPARE PARTS AND ACCESSORIES

	Paragraph
Spare parts .....	61
Accessories .....	62
Baffle, primer flame .....	63
Book, artillery gun .....	64
Brush, slush .....	65
Covers .....	66
Device, bore greasing, 12-inch, M4 .....	67
Extractor, power, for dummy projectiles .....	68
Pan, drip .....	69
Rammer and staff .....	70
Scraper .....	71
Tongs, shot .....	72
Tools, firing mechanism .....	73
Truck, shot .....	74
Wrenches .....	75

61. SPARE PARTS.

a. Organization spare parts are supplied to the using arm for replacement of those parts most likely to become broken, worn or otherwise unserviceable. Standard Nomenclature Lists, which ordinarily contain a list of those spare parts which should be maintained as a set, will not be published for this materiel. However, a list of the parts of the mortar which are most likely to fail and which are commonly issued to battery personnel for repair purposes is furnished below. This list is not necessarily correct for any one battery but is intended as a guide for the stocking of spare parts. Repair parts for the carriage must be procured and replaced by ordnance personnel. An inventory of the parts stocked at the battery should be kept at all times. The spare parts listed below should be drawn through the representative corps area headquarters. Sets of spare parts should be maintained as complete as possible at all times and should be kept clean and oiled to prevent rust.

**ORGANIZATION SPARE PARTS AND ACCESSORIES**  
*SPARE PARTS FOR 12-INCH MORTAR M1890MI*

Piece Mark or Drawing No.	Item
	<b>SPARE PARTS</b>
	PARTS, spare, 12-in. Mortar, M1890MI, set
	(Consisting of:
15-OK-13	2 BAR, safety
—	1 BREECH, mechanism, complete
15-OK-13	2 CATCH, slide
15-10K-15	2 CLIP, bridle
62-2-29	4 DISK, filling-in
15-OK-13	3 EJECTOR
15-OK-13	2 FIRING mechanism
15-OK-13	2 HOUSING, firing mechanism
62-2-29	4 PAD, gas check
62-2-2	2 PIN, hinge
15-10K-15	5 PLUG, spindle
62-2-29	4 RING, split, front
62-2-29	4 RING, split, rear
62-2-6	3 SCREW, breechblock oilhole
15-OK-13	2 SCREW, firing leaf spring
62-2-2	4 SCREW, hinge pin oilhole
62-2-29	2 SCREW, obturator nut clamping
15-OK-13	2 SLIDE, firing mechanism
62-2-28	2 SLIDE, safety bar
15-10K-15	3 SPRING, clip bridle
15-OK-13	4 SPRING, collar catch
15-OK-13	4 SPRING, firing leaf
62-2-2	4 SPRING, rotating crank lock
15-OK-13	4 SPRING, slide catch
15-OK-13	4 SPRING, slide stop
15-OK-13	4 SPRING, tray spring bolt
62-2-2	2 STUD, translating)

**62. ACCESSORIES.**

a. Accessories include tools and equipment required for such disassembling and assembling as the using arm is authorized to perform, and for the cleaning and preserving of the mortar, carriage, ammunition, etc. They also include chests, covers, tool rolls, and other items necessary to protect the materiel when it is not in use. Additional accessories and supplies of a general nature are provided for battery use. Accessories should not be used for purposes other than as prescribed, and when not in use should be properly stored.

**12-INCH SEACOAST MATERIEL**

b. There are a number of accessories whose names or general characteristics indicate their use. Others, embodying special features or having special uses, are described below.

**63. BAFFLE, PRIMER FLAME.**

a. This is a small plate which fits over the venthole in back of the mushroom head of the obturator spindle. It is used when firing primers for test purposes to avoid fouling the bore of the mortar. It is stored in the same chest with the subcaliber equipment. To install the baffle, proceed as follows: Remove dummy pressure plugs, attach baffle, and replace plugs to retain the baffle on the obturator head. Fire the primers. Remove baffle plate and replace plugs. Clean the ventholes and primer seat.

**64. BOOK, ARTILLERY GUN.**

a. The gun book (O.O. Form 5825) is used to keep an accurate record of the materiel. It includes records of assignments, the battery commander's daily record, and the inspector's record of ammunition, as well as forms to be filled out in case of premature explosions. This book should be in the possession of the organization at all times. The completeness of the records and the whereabouts of the book are responsibilities of the battery commander. It must also contain the date of issuance of the materiel, to and by whom issued, and the place where issued. If a new cannon is installed on the carriage, all data in the old book with reference to sights, carriage, etc., must be copied into the new gun book before the old gun book is relinquished.

**65. BRUSH, SLUSH.**

a. The spiral bristle brush with bronze shank is used in oiling the bore.

**66. COVERS.**

a. The muzzle cover is made of sheet metal. It is felt-padded and duck-lined and designed to fit over the muzzle for its protection when the mortar is not in use.

b. The breech cover is made of olive-drab cotton duck and designed to fit over the breech of the mortar for its protection when not in use.

**67. DEVICE, BORE GREASING, 12-INCH, M4.**

a. **Description.** The bore greasing device (fig. 53) consists of three parts: two friction disks assembled to a spacer, a smoothing brush and spreading disk assembly, and a shaft fitted with an eye on each end. The friction disks serve as guides. They keep the shaft centered and parallel to the bore of the mortar. This, in turn, centers the slushing com-

## ORGANIZATION SPARE PARTS AND ACCESSORIES

pound spreading disk, which is assembled to the brush assembly, and insures an even pressure of brush bristles against the bore of the mortar. The friction device and brush assembly are free to slide on the shaft.

### b. Method of Slushing Bore.

(1) Attach the dragline to the fixed eye on the shaft of the bore-slushing device and insert in the muzzle end of the mortar. As the first friction disk enters the bore of the mortar, the studs in the rim of the disk (fig. 53) will strike against the muzzle face of the mortar. These studs are held out by springs recessed in the disk. Compress the studs by wooden sticks held against their ends and insert both disks. Push the friction disks in, holding the shaft, until the device is in the position shown in figure 53 (2, fig. 54), i.e., with the friction disk assembly to the extreme end of the shaft and the other end of the shaft extending out beyond the muzzle face of the mortar a distance equal to the thickness of the smoothing brush and spreading disk assembly. This will allow the smoothing brush and spreading disk assembly to be fitted after the slushing compound has been applied.

(2) Pack the slushing compound in the muzzle end of the mortar (4, fig. 54), taking care to pack solid with no air pockets. Care should also be taken to prevent the bore-slushing device from being pushed breechward during this operation. In some instances it may be necessary to hold the shaft in order to prevent this breechward movement.

(3) Install the smoothing brush and spreading disk assembly with spreading disk next to the slushing compound (5, fig. 54). At this point, coat the brush bristles with slushing compound to insure slushing of the first few inches of the bore at the beginning of the pulling operation.

(4) By means of the dragline (6, fig. 54) pull the bore-slushing device and slushing compound through the bore of the mortar. The force of the pull is exerted on the brush and spreading disk assembly which pushed the slushing compound and friction disks through the bore. Pressure is built up against the compound by the resistance of the friction disks, causing the compound to ooze out around the spreading disk and fill the grooves. After the bore-slushing device has been drawn through the bore to the point where the friction disks enter the chamber, pressure against the compound is lost and, to compensate for this loss of resistance and to slush the last several inches of rifling, it is necessary to hold a pole or staff against the friction disk.

(5) The pull on the dragline may be supplied by hand or, where space will permit, by a tractor. Care should always be taken to keep the direction of pull along the axis of the bore. Once the pulling operation is started, it is desirable to continue the pull until the bore is completely

12-INCH SEACOAST MATERIEL

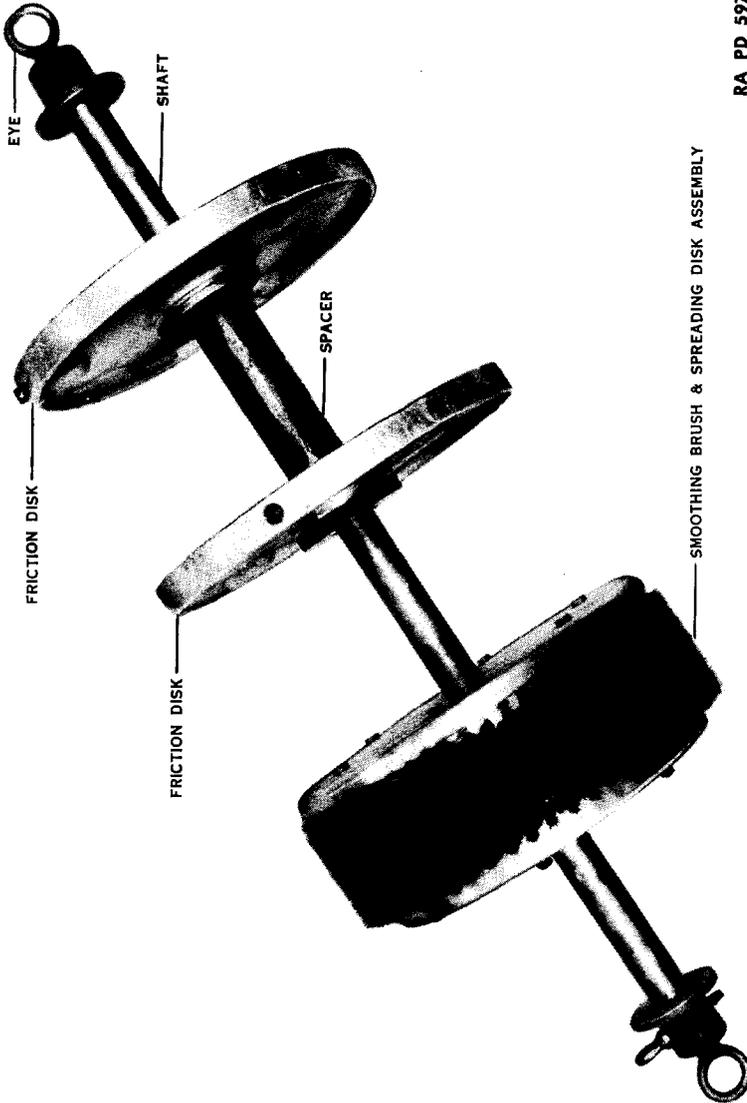

RA PD 5970

Figure 53 — DEVICE, Bore Greasing, 12-inch, M4

## ORGANIZATION SPARE PARTS AND ACCESSORIES

slushed; each stop and start leaves a heavy ring of slushing compound in the bore.

(6) An alternate method of placing the bore-slushing device in the bore is to draw it in from the breech end. This can be accomplished by passing a light line through the bore from the muzzle end and attaching the line to the eye on the brush end of the slushing device. As the slushing device is being pulled through by the light line, the dragline to be used in the slushing operation is attached to the other end of the slushing device and drawn through at the same time.

### 68. EXTRACTOR, POWER, FOR DUMMY PROJECTILES.

a. The power extractor (similar to gun extractor shown on fig. 58) consists of a round steel bar, a yoke, and a nut and washer. The bar is tapered and has a hook on its larger end that hooks into the projectile. The yoke is placed over the smaller end of the bar to fit against the breech end of the mortar. The smaller end is threaded for the nut and by screwing up the nut on the bar against the yoke, pressure is applied to the bar which loosens the dummy projectile.

### 69. PAN, DRIP.

a. Drip pans are provided for use on the lower ends of recoil cylinders to catch oil that might soak through when the carriage is not in use or while followers in the stuffing boxes are being tightened.

### 70. RAMMER AND STAFF.

a. The assembled rammer and staff is commonly called the rammer. It is used to ram the projectile firmly into its seat in the bore of the mortar. The rammer proper is an aluminum, cone-shaped head provided with a coupling for fastening the staff. A scale is marked on the cylindrical wooden staff to indicate when the projectile is properly seated in the bore.

### 71. SCRAPER.

a. The scraper is used to scrape corrosion and rust preventive compound from the bore of the mortar prior to cleaning and slushing operations. It should not be used for scraping copper deposits from the bore. Decoppering the bore is prohibited. The scraper consists of a semicircular steel blade which is secured to one end of a socket with a bronze nut. The staff is screwed into the other end of the socket when required.

### 72. TONGS, SHOT.

a. The shot tongs are a pair of steel hooks which are designed to grip the projectile near its center of gravity. They are used to load the shot truck.

12-INCH SEACOAST MATERIEL

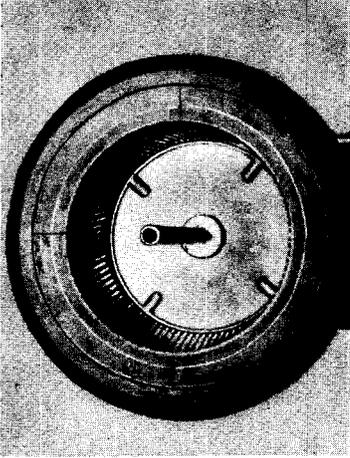

3

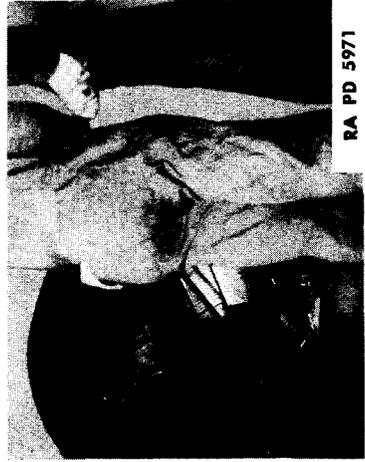

RA PD 5971

6

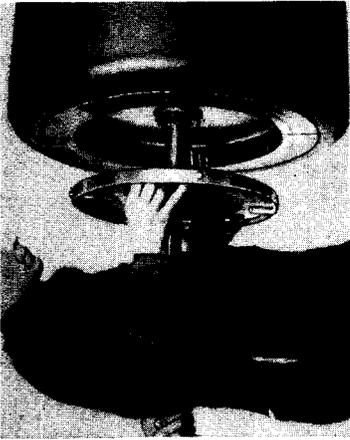

2

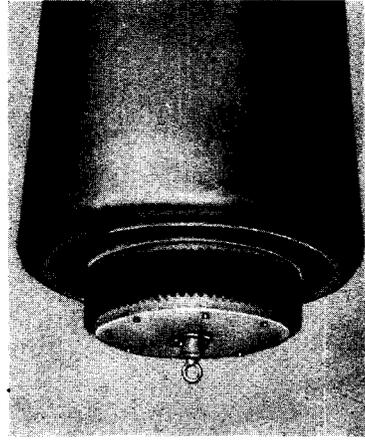

5

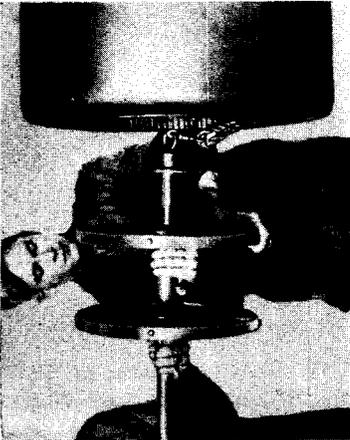

1

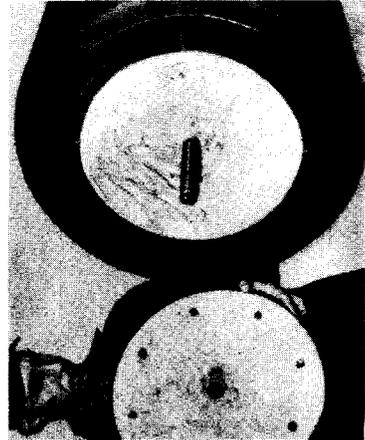

4

Figure 54—Method of Slushing Bore

ORGANIZATION SPARE PARTS AND ACCESSORIES

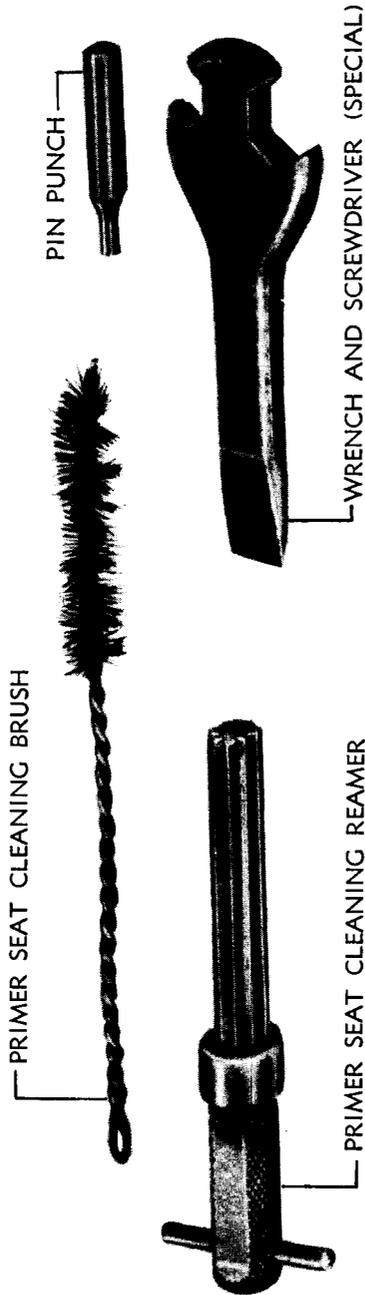

RA PD 9968

Figure 55—Tools for Seacoat Firing Mechanism M1903

**12-INCH SEACOAST MATERIEL**

**73. TOOLS, FIRING MECHANISM.**

a. The firing mechanism tools (fig. 55) consist of: one primer seat cleaning brush, one pin punch, one primer seat cleaning reamer, and one special wrench and screwdriver.

(1) The primer seat cleaning brush is a small twisted wire brush used to clean the primer seat and parts of the firing mechanism.

(2) The pin punch is used in assembly and disassembly of the firing mechanism.

(3) The primer seat cleaning reamer is used to ream out and clean the primer seat.

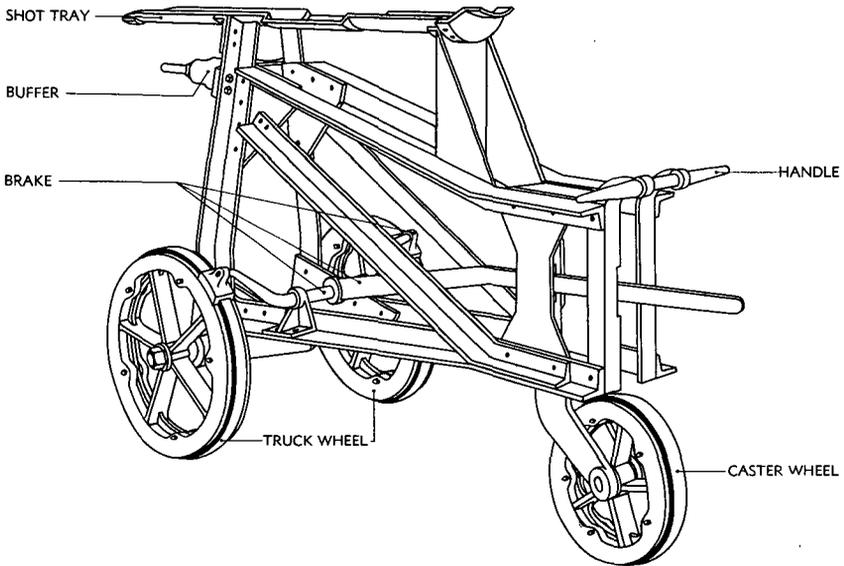

RA PD 7271

**Figure 56—12-Inch Mortar Carriage M1896M1 and M1896 M11—  
Shot Truck**

## ORGANIZATION SPARE PARTS AND ACCESSORIES

(4) One end of the special wrench and screwdriver is a screwdriver while the other is the wrench end. This tool is used to unscrew the slide stop from the housing when replacing a broken spring. It is also used to unscrew the nut on the under side of the leaf when removing the contact clip. To remove the collar catch, the screwdriver end is used to unscrew the screw at the lower edge of the housing.

### 74. TRUCK, SHOT.

a. The shot truck (fig. 56) is made up of steel angles riveted and bolted together to form a framework supported by two truck wheels and two caster wheels. On top of the framework is a fixed shot tray. The shot truck is provided with a buffer which takes the shock as the front end of the shot tray is pushed into the breech. Two wooden handles are provided at the rear for maneuvering the truck.

### 75. WRENCHES.

a. The obturator nut wrench (1, fig. 57) is a special box wrench to which is attached a T-shaped handle. This wrench is used to tighten obturator nut which is screwed on rear end of obturator spindle.

b. The obturator nut clamp screw wrench (2, fig. 57) is a special box wrench. It is used for tightening clamp screw which prevents accidental loosening of obturator nut which is on rear end of obturator spindle.

c. The tit wrench (3, fig. 57) for obturator is a piece of flat forged steel, at one end of which are two tits. It is used on obturator spindle.

d. The pressure plug wrench (4, fig. 57) is a box wrench (1.52-in. hex.). It has a  $13\frac{7}{8}$ -inch handle. It is used on pressure plugs in obturator.

e. The wrench (5, fig. 57) for screwdriver is a round steel rod. At a point halfway from each end is a bulge, in the center of which is a square hole. It is used in connection with larger bar screwdrivers.

f. The gland wrench (6, fig. 57) is a flat piece of steel on one end of which is a small right-angle bend. At the same end a slot is cut to fit gland nut. It also has stamped on one side "LAMP JUNCTION BOX GLAND."

g. The lower follower spanner wrench (7, fig. 57) is a Y-shaped steel hook spanner type wrench. The two hooks at the Y-end fit into notches of the recoil cylinder follower. At the other end are two holes at right angles to each other through which rod—U44GA may be inserted

**12-INCH SEACOAST MATERIEL**

halfway to form a handle. The wrench is used to remove follower at lower end of recoil cylinder.

**h.** The piston rod nut wrench (8, fig. 57) is a single end wrench which is used on two nuts on front end of each piston rod so that piston rod may be removed from recoil cylinder.

**i.** The spring rod nut wrench (9, fig. 57) is a double end wrench used on the spring guide rod nuts in the counterrecoil springs.

ORGANIZATION SPARE PARTS AND ACCESSORIES

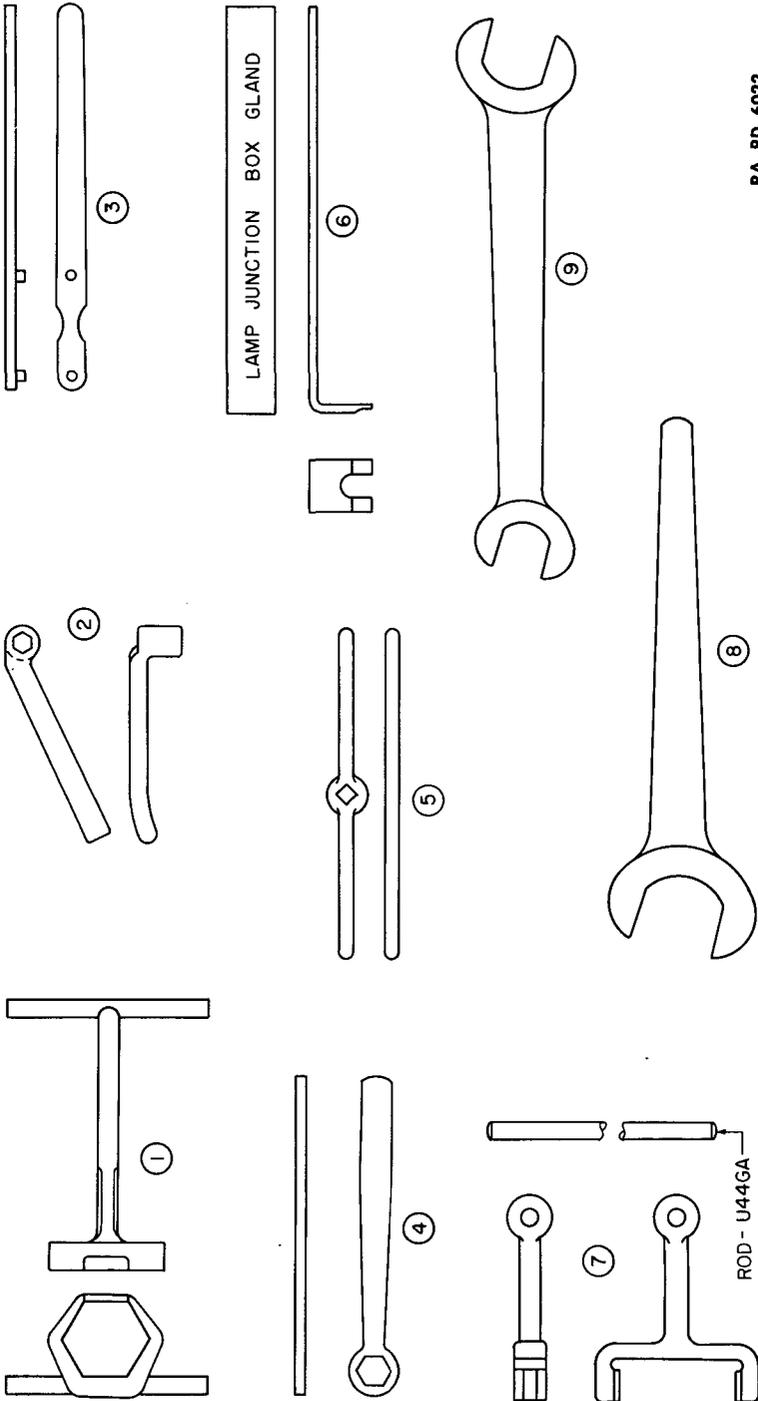

RA PD 6022

Figure 57 --Tools

## 12-INCH SEACOAST MATERIEL

### Section XI

## SUBCALIBER EQUIPMENT

	Paragraph
Purpose .....	76
Materiel .....	77
Installing subcaliber tube .....	78
Operation .....	79
Care and maintenance .....	80

### 76. PURPOSE.

a. Subcaliber equipment is used for training purposes only, to provide practice in laying and firing the 12-inch mortar materiel. The use of smaller bore ammunition prevents wear on the regular piece during practice and is less costly. Although the handling and loading, as well as the range obtained, differ from those of the regular piece, the elevating, traversing, sighting, etc., are adequate for instructional purposes.

### 77. MATERIEL.

a. The subcaliber equipment is stored in a chest which contains the following:

#### *LIST OF MATERIEL CARRIED IN THE SUBCALIBER EQUIPMENT CHEST*

1 ADAPTER, front	1 PLATE, obturator spindle
1 ADAPTER, rear	1 ROD, sponge
1 BAFFLE, primer flame	1 SCREW, clamp wedge
1 CAN, oil	2 SCREWS, securing
1 EXTRACTOR, clip	2 SCREWS, thread clamp
1 EXTRACTOR, gun complete	1 SPONGE, cleaning
1 EXTRACTOR, hand	1 WEDGE, adapter clamp
1 GAGE, locating	1 WRENCH, adjusting
1 GUN, subcaliber, 2.95-inch.	1 WRENCH, clamping
1 HANDSPIKE	1 WRENCH, securing screw

b. **ADAPTER, rear.** The rear adapter (fig. 59) is the rear support of the subcaliber gun in the bore of the mortar. The adapter clamp wedge is inserted in an opening of the rear adapter and then is forced against the chamber wall of the mortar by screwing in the clamp wedge screw.

c. **EXTRACTOR, clip.** The clip extractor (fig. 58) is used when an empty cartridge case sticks and cannot be removed with the hand extractor. The clip extractor has three claws that fit over the rim of the

SUBCALIBER EQUIPMENT

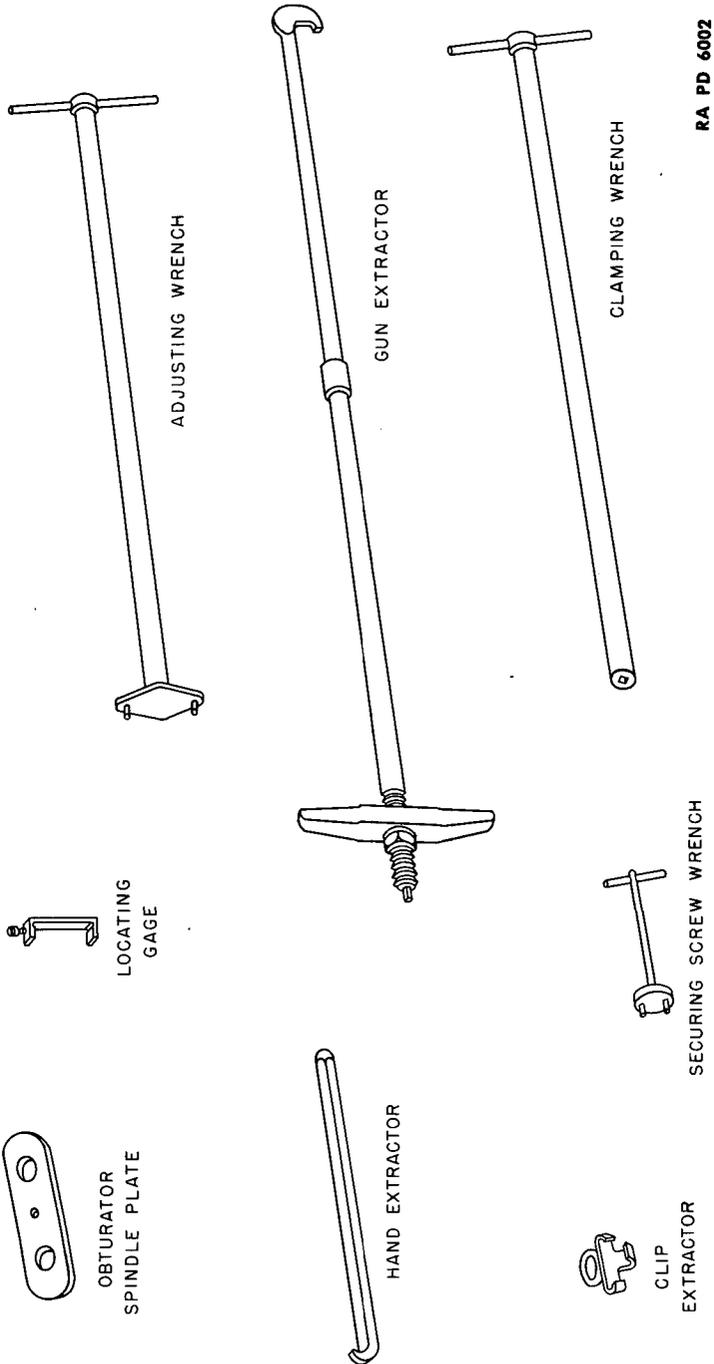

Figure 58—Tools for Subcaliber Gun

**12-INCH SEACOAST MATERIEL**

subcaliber cartridge case. Back of the claws is an eye. A light rope may be passed through the eye of the extractor and, if necessary, the rope may be wrapped around a lever placed against the face of breech.

**d. EXTRACTOR, hand.** The hand extractor (fig. 58) is used on the flange or rear adapter of the subcaliber gun in case the gun should stick in its seat.

**e. EXTRACTOR, gun.** The gun extractor is used as a puller for removing the subcaliber gun from the bore of the mortar.

**f. GAGE, locating.** The locating gage (figs. 58, 59) is a U-shaped clamp with set screw used to locate the subcaliber gun in the bore of the mortar. The gage is slipped over the obturator spindle plate, leaving a space between gage and spindle plate, and the breech is closed gently. If resistance is encountered, the subcaliber gun is too far to the rear. The breech is opened and the subcaliber gun turned clockwise. If no resistance is encountered in closing, the breech is opened to note whether the gage has been pushed back against the spindle plate. If the gage has not been pushed all the way back, the subcaliber gun is unscrewed one turn for each 0.1 inch. This is kept up until the gage is pushed just against the spindle plate when closing the breech. The thread clamp screw is tightened to prevent subcaliber gun from turning.

**g. GUN, subcaliber, 2.95-inch.** This gun (fig. 59) is a tube 31.6 inches long which has a bore of 2.95 inches. It is supported in the bore of the mortar by two supports (the rear and front adapters).

**h. WEDGE, adapter clamp.** The adapter clamp wedge (fig. 59) is a steel wedge used to wedge the rear adapter tightly against the walls of the chamber of the mortar.

**i. WRENCHES.**

(1) The securing screw wrench (fig. 58) is used to tighten the two securing screws of the obturator spindle plate. It is a small wrench which consists of a T-shaped handle attached to a steel plate which has two pins that fit into two small holes in the securing screw.

(2) The clamping wrench (fig. 58) consists of a steel cylindrical rod on one end of which is a T-shaped handle. A square opening in the center of the other end fits the clamping screw. The clamping wrench is used to tighten the clamp wedge screw in the rear adapter, which in turn causes the rear adapter to be wedged against the walls of the chamber.

(3) The adjusting wrench (fig. 58) is a cylindrical steel rod with a T-shaped handle at one end and a steel plate with two pins attached to the other. This wrench in general appearance resembles the securing screw wrench, but it is much larger and is used with the locating gage in adjusting the subcaliber gun in the bore of the mortar.

## SUBCALIBER EQUIPMENT

### 78. INSTALLING SUBCALIBER TUBE.

a. To mount the subcaliber gun in the bore of the mortar proceed as follows:

(1) Chamber and bore of subcaliber gun and of mortar must be perfectly clean. Remove pressure plugs from mushroom head and put on obturator spindle plate with its two screws, tightening with the securing screw wrench. Screw the front and rear adapters onto the tube. Insert the subcaliber tube into the mortar chamber, pushing it smartly forward with the handspike to cause front adapter to seat firmly in the tapered part of the chamber. Using the clamping wrench, tighten clamp wedge screw in rear adapter to cause adapter clamp wedge to expand adapter against the walls of chamber. Remove handspike.

(2) **ADJUSTMENT.** The subcaliber tube is in correct adjustment when the locating gage is pushed just against the obturator spindle plate when the mortar breech is closed. To adjust, slip locating gage over obturator spindle plate, leaving a space between gage and spindle plate. Close breech gently. If resistance between the mortar breech and subcaliber tube is encountered, the tube is too far to the rear. Open breech and turn the tube clockwise. If it has not been pushed all the way back, measure the distance between plate and gage and unscrew the tube one turn for each 0.1 inch. Continue to try in this manner until gage is pushed just against spindle plate when closing the breech. Having adjusted subcaliber gun until locating gage is pushed against spindle plate by closing breech, tighten thread clamp screw with clamping wrench to prevent subcaliber gun from turning. The gun is then ready to fire.

(3) **DISASSEMBLY.** Ease up both clamp screws, insert handspike, lift on handspike to support the weight, and pull subcaliber gun to rear and out; if not easily withdrawn, use gun extractor.

### 79. OPERATION.

a. Operation of the subcaliber gun is identical with operation of the mortar except that powder and projectile are not loaded separately because the subcaliber ammunition is in the form of fixed complete rounds.

#### b. To Load the Gun:

- (1) Depress the mortar to zero elevation.
- (2) Insert a round and impel it into the chamber.
- (3) Close the breech.

#### c. To Fire the Gun:

(1) Elevate the mortar, as with the regular ammunition and fire, observing the same precautions as are observed for firing the mortar.

**12-INCH SEACOAST MATERIEL**

(2) Remove empty cartridge case after each round with the hand extractor. If the empty cartridge case sticks when the limit of extraction given by hand extractor is reached, use the clip extractor. A light rope may be passed through the eye of this extractor and, if necessary, the rope may be wrapped around a lever placed against face of the breech.

d. After one or two rounds the position of the locating gage should be checked to insure that the gun has not moved forward. Any fouling of vent in obturator must be removed with vent cleaner.

**80. CARE AND MAINTENANCE.**

a. Special care should be taken in assembling and disassembling to prevent the outside surfaces of the adapters from coming in contact with any hard substance. If a bur should appear, it must be smoothly filed down before assembling. Particular care must be taken in loading not to drive the point of the shell against the edge of the chamber of the subcaliber gun. The clamp screws and adapter hubs should always be kept well oiled with OIL, engine, SAE 10. An oil can is provided for this purpose. After firing, the bore of the subcaliber gun should be thoroughly sponged with a solution of ½ to 1 pound of SODA ASH or 1 to 1½ pounds of sal soda in each gallon of water or with warm soapsuds. It should then be dried, and oiled with OIL, engine, seasonal grade. The chamber and bore of the mortar should also be thoroughly cleaned, dried, and oiled with OIL, engine, seasonal grade.

SUBCALIBER EQUIPMENT

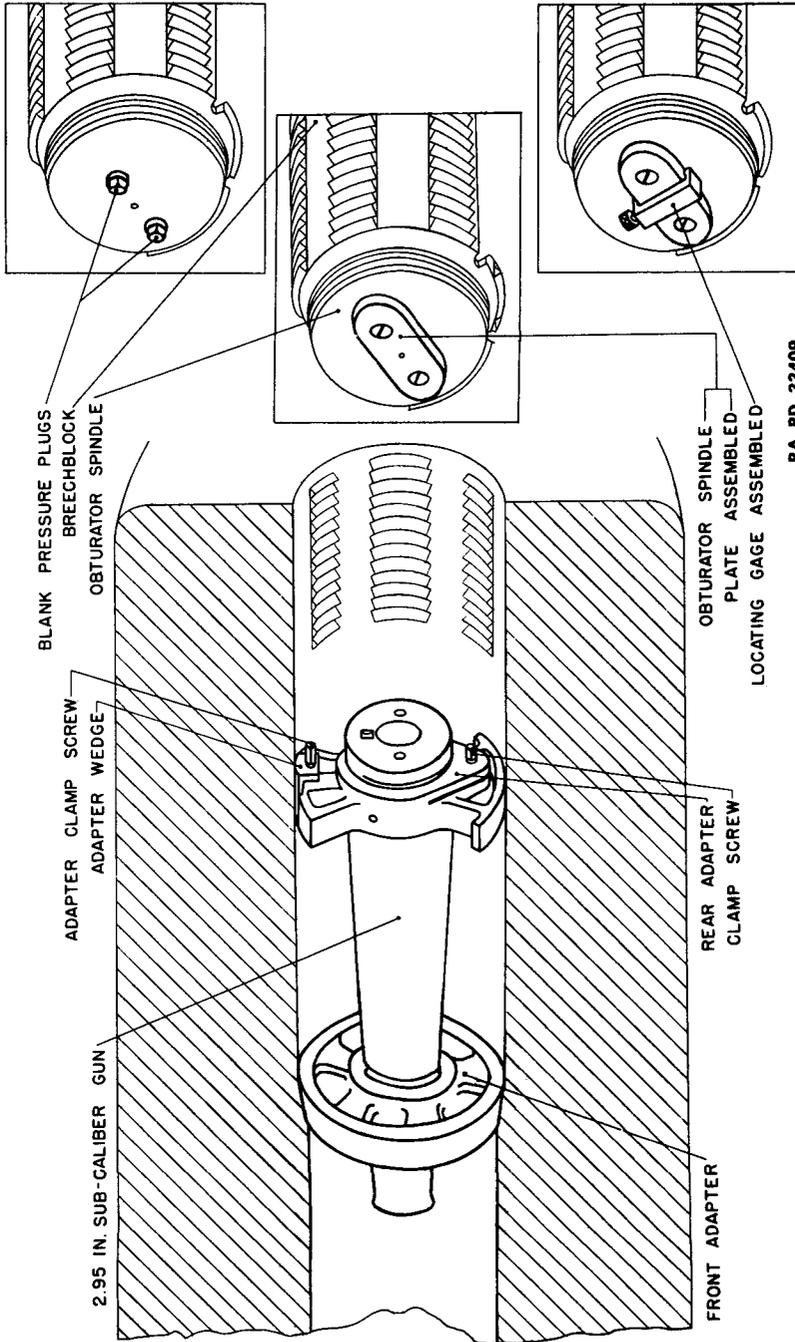

RA PD 33409

Figure 59 — 2.95-Inch Subcaliber Gun — Assembled

12-INCH SEACOAST MATERIEL

Section XII

**PAINTING**

	Paragraph
General .....	81
Preparing for painting .....	82
Painting metal surfaces .....	83
Removing paint .....	84
Painting lubricating devices .....	85

**81. GENERAL.**

a. Paint is used for preservation against rust, deterioration, and decay of metals and woods. Some paints adhere to metal surfaces better than others, the liquids of the first or base coat seeming to penetrate very minute depressions or pits in the metal or to etch themselves into the surface and thus form a good bond for following coats. Paints stored in large containers should be well stirred before transfer to small containers.

b. All parts of the mortar and the mortar carriage will be painted, with the exception of wearing or bearing parts and sliding surfaces. Groups normally considered to be wearing or bearing parts and sliding surfaces are:

- All parts of breechblock.
- Trays, both steel and bronze.
- Square ends of shafts.
- Teeth of all gears.
- Rollers and surfaces on which rollers travel.
- Piston rods.
- Cross head guides.
- Handles of cranks, handwheels and clutches.
- Azimuth and elevation scales and pointers.
- Followers of stuffing boxes.
- Lanyard safety pawls.

(1) The background of name and direction plates will be painted red, but the raised portions of the letters, figures, arrows, and rims are to be kept bright and free from paint. Name plates should never be removed from the carriage.

c. All paint should be well stirred before using. If too thick, it should be thinned with TURPENTINE or THINNER, but not to such an extent that the paint does not cover. The exact and proper thickness of each paint can be learned only by experience. If too thin, it often cracks in

## PAINTING

drying, and if too thick, it becomes blistered, wrinkled, and unequal. The first coat may, however, be much thinner than any of the succeeding coats.

d. Ordnance materiel is ordinarily given one maintenance coat per year. With but few exceptions, this materiel will be painted with ENAMEL, synthetic, olive drab, lusterless. The enamel may be applied over old coats of long oil enamel and oil paint previously issued by the Ordnance Department, if the old coat is in satisfactory condition of repainting. This enamel is used for both metal and wood surfaces, the primer base coat for metal being different from that for wood (par. 82).

e. Paints and enamels are usually issued ready for use and are applied by brush or spray. They may be brushed on satisfactorily when used unthinned in the original package consistency or when thinned no more than 5 percent by volume with THINNER. The enamel will spray satisfactorily when thinned with 15 percent by volume of THINNER. (Linseed oil must not be used as a thinner, since it will impart a luster not desired in this enamel.) If sprayed, it dries hard enough for repainting within ½ hour and dries hard in 16 hours.

f. Certain exceptions to the regulations concerning painting exist. Fire control instruments, sighting equipment, and other items which require a crystalline finish will not be painted with olive-drab enamel.

g. Complete information on painting is contained in TM 9-850.

### 82. PREPARING FOR PAINTING.

a. If the base coat on the materiel is in poor condition, it is more desirable to strip the old paint from the surface than to use sanding and touch-up methods. After stripping, it will then be necessary to apply a primer coat.

b. PRIMER, ground, synthetic, should be used on wood as a base coat for synthetic enamel. It may be applied either by brushing or spraying. It will brush satisfactorily as received, or after the addition of not more than 5 percent by volume of THINNER. It will dry enough to touch in 30 minutes, and hard in 5 to 7 hours. For spraying, it may be thinned with not more than 15 percent by volume of THINNER. Lacquers must not be applied to the PRIMER, ground, synthetic, within less than 48 hours.

c. PRIMER, synthetic, rust inhibiting, for bare metal, should be used on metal as a base coat. Its use and application is similar to that of PRIMER, ground, synthetic.

d. The success of a job of painting depends partly on the selection of a suitable paint, but also largely upon the care used in preparing the

**12-INCH SEACOAST MATERIEL**

surface prior to the painting. All parts to be painted should be free from rust, dirt, grease, kerosene, oil and alkali, and must be dry and smooth.

**83. PAINTING METAL SURFACES.**

a. If metal parts are in need of cleaning, they should be washed in a liquid solution consisting of  $\frac{1}{2}$  pound of SODA ASH in 8 quarts of warm water, or an equivalent solution, then rinsed in clear water and wiped thoroughly dry. Wood parts in need of cleaning should be treated in the same manner, but the alkaline solution must not be left on for more than a few minutes, and the surfaces should be wiped dry as soon as they are washed clean. When artillery is in fair condition and only marred in spots, the bad places should be touched with ENAMEL, synthetic, olive drab, lusterless, and permitted to dry. The whole surface will then be sandpapered with PAPER, flint, No. 1, and a finish coat of ENAMEL, synthetic, olive drab, lusterless, applied and allowed to dry thoroughly before the materiel is used. If the equipment is in bad condition, all parts should be thoroughly sanded with PAPER, flint, No. 2, or equivalent, given a coat of PRIMER, ground, synthetic, and permitted to dry for at least 16 hours. They will then be sandpapered with PAPER, flint, No. 00, wiped free of dust and dirt, and a final coat of ENAMEL, synthetic, olive drab, lusterless, applied and allowed to dry thoroughly before the materiel is used.

**84. REMOVING PAINT.**

a. After repeated paintings, the paint may become so thick as to crack and scale off in places, presenting an unsightly appearance. If such is the case, remove the old paint as follows: Dissolve 1 pound of SODA, caustic (lye), in 6 pints of hot water and add enough LIME, hydrated, to give the solution the consistency of paint. Use the solution freshly mixed and apply to parts where paint is to be removed with a swab of cotton rags, or cotton waste, tied to the end of a stick. When the solution begins to dry on the surface, use a scraper to remove the old paint and complete the cleaning of the surface with a mop and water. If one application is not sufficient to loosen the paint, apply a second coat. If a lime-and-lye solution is not available, REMOVER, paint and varnish, may be used. It is important that every trace of lye or other paint remover be completely rinsed off and that the equipment be perfectly dry before repainting is attempted. It is preferable that the use of lye solutions be limited to iron or steel parts. If used on wood, the lye solutions must not be allowed to remain on the surface for more than a minute before being thoroughly rinsed off and the surface wiped dry with rags. Crevices or cracks in wood should be filled with putty and the wood sandpapered before refinishing.

**PAINTING**

**85. PAINTING LUBRICATING DEVICES.**

a. A circle about  $\frac{3}{4}$  inch in diameter around oil cups, grease fittings, oilholes, and similar lubricating devices, as well as a circle about  $\frac{3}{4}$  inch in diameter at each point of lubrication will be painted with **ENAMEL**, red, water resisting, in order that they may be readily located. Avoid getting paint directly on grease fittings, oil cups, and oilholes.

12-INCH SEACOAST MATERIEL

Section XIII

**MATERIEL AFFECTED BY GAS**

	Paragraph
Protective measures .....	86
Cleaning .....	87
Decontamination .....	88

**86. PROTECTIVE MEASURES.**

a. When materiel is in constant danger of gas attack, unpainted metal parts will be lightly coated with engine oil. Instruments are included among the items to be protected by oil from chemical clouds or chemical shells, but ammunition is excluded. Care will be taken that the oil does not touch the optical parts of instruments, or leather or canvas fittings. Materiel not in use will be protected with covers as far as possible. Powder will be kept in sealed containers.

b. Ordinary fabrics offer practically no protection against mustard gas or lewisite. Rubber and oilcloth, for example, will be penetrated within a short time. The longer the period during which they are exposed, the greater the danger of wearing these articles. Rubber boots worn in an area contaminated with mustard gas may offer a grave danger to men who wear them several days after the bombardment. Impermeable clothing will resist penetration more than an hour, but should not be worn longer than this.

**87. CLEANING.**

a. All unpainted metal parts of materiel that have been exposed to any gas except mustard and lewisite must be cleaned as soon as possible with SOLVENT, dry-cleaning, or ALCOHOL, denatured, and wiped dry. All parts should then be coated with engine oil (except fire control equipment). Clean all shiny exterior surfaces, the bore, the breech chamber, and the parts of the breech mechanism.

b. Ammunition which has been exposed to gas must be thoroughly cleaned before it can be fired. To clean ammunition use AGENT, decontaminating, noncorrosive, or if this is not available, strong soap and cool water. After cleaning, wipe all ammunition dry with clean rags. Do not use dry powdered AGENT, decontaminating (chloride of lime), for decontaminating certain types of materiel on or near ammunition supplies, as flaming occurs through the use of chloride of lime on liquid mustard.

**MATERIEL AFFECTED BY GAS****88. DECONTAMINATION.**

a. For the removal of liquid chemicals (mustard, lewisite, etc.) from materiel, the following steps should be taken:

**(1) PROTECTIVE MEASURES.**

(a) For all these operations a complete suit of impermeable clothing and a service gas mask will be worn. Immediately after removal of the suit, a thorough bath with soap and water (preferably hot) must be taken. If any skin areas have come in contact with mustard, if even a very small drop of mustard gets into the eye, or if the vapor of mustard has been inhaled, it is imperative that complete first-aid measures be given within 20 to 30 minutes after exposure. First-aid instructions are given in TM 9-850 and FM 21-40.

(b) Garments exposed to mustard will be decontaminated. If the impermeable clothing has been exposed to vapor only, it may be decontaminated by hanging in the open air, preferably in sunlight for several days. It may also be cleaned by steaming for 2 hours. If the impermeable clothing has been contaminated with liquid mustard, steaming for 6 to 8 hours will be required. Various kinds of steaming devices can be improvised from materials available in the field.

**(2) PROCEDURE.**

(a) Commence by freeing materiel of dirt through the use of sticks, rags, etc., which must be burned or buried immediately after this operation.

(b) If the surface of the materiel is coated with grease or heavy oil, this grease or oil should be removed before decontamination is begun. SOLVENT, dry-cleaning, or other available solvents for oil should be used with rags attached to ends of sticks. Following this, decontaminate the materiel with bleaching solution made by mixing one part AGENT, decontaminating (chloride of lime), with one part water. This solution should be swabbed over all surfaces. Wash off with water, dry, and oil all surfaces.

(c) All unpainted metal parts and instruments exposed to mustard or lewisite must be decontaminated with AGENT, decontaminating, non-corrosive, mixed 1 part solid to 15 parts solvent (ACETYLENE TETRACHLORIDE), by weight. If this is not available, use warm water and soap. Bleaching solution must not be used, because of its corrosive action. Instrument lenses may be cleaned only with PAPER, lens, tissue, using a small amount of ALCOHOL, ethyl. Coat all metal surfaces lightly with engine oil.

(d) In the event AGENT, decontaminating (chloride of lime), is not available, materiel may be temporarily cleaned with large volumes of

**12-INCH SEACOAST MATERIEL**

hot water. However, mustard lying in joints or in leather or canvas webbing is not removed by this procedure and will remain a constant source of danger until the materiel can be properly decontaminated. All mustard washed from materiel in this manner lies unchanged on the ground, necessitating that the contaminated area be plainly marked with warning signs before abandonment.

(e) The cleaning, or decontaminating, of materiel contaminated with lewisite will wash arsenic compounds into the soil, poisoning any water supplies in the locality for either men or animals.

(f) Leather or canvas webbing that has been contaminated should be scrubbed thoroughly with bleaching solution. In the event this treatment is insufficient, it may be necessary to burn such material.

(g) Detailed information on decontamination is contained in FM 21-40, TM 9-850 and TC 38, 1941, Decontamination.

Section XIV

REFERENCES

	Paragraph
Standard nomenclature lists .....	89
Explanatory publications .....	90
Firing tables .....	91
Army regulations .....	92

89. STANDARD NOMENCLATURE LISTS:

a. Ammunition.

- Ammunition, fixed, including subcaliber ammunition, for harbor defense, heavy field, and railway artillery ..... SNL P-6
- Ammunition Instruction Material, for antiaircraft, harbor defense, heavy field, and railway artillery ..... SNL P-8
- Charges, propelling, separate loading, 10-inch to 16-inch inclusive, for harbor defense, heavy field, and railway artillery ..... SNL P-4
- Fuzes, Primers, Blank Ammunition, and miscellaneous items for antiaircraft, harbor defense, heavy field, and railway artillery ..... SNL P-7
- Projectiles, separate loading, 10-inch to 16-inch inclusive, for harbor defense, heavy field, and railway artillery, including complete round data ..... SNL P-3

- b. Cleaning, preserving, and lubricating materials, recoil fluids, special oils, and similar items of issue ..... SNL K-1

- c. Major items of railway and permanent and semi-permanent artillery ..... SNL E-1

d. Sighting and Fire Control Equipment.

- Harbor defense, railway and antiaircraft artillery sighting equipment and fire control instruments —major items ..... SNL F-2
- Firing tables and trajectory charts ..... SNL F-69

- e. Maneuvering material and supplies ..... SNL N-1

Current Standard Nomenclature Lists are as tabulated here. An up-to-date list of SNL's is maintained as the "Ordnance Publications for Supply Index" ..... OPSI

**12-INCH SEACOAST MATERIEL**

**90. EXPLANATORY PUBLICATIONS:**

	<b>Paragraph</b>
<b>a. Ammunition.</b>	
Ammunition, general .....	TM 9-1900
Coast Artillery Ammunition .....	TM 4-205
Range regulations for firing ammunition for training and target practice .....	AR 750-10
<b>b. Care and Preservation.</b>	
Cleaning, preserving, lubricating and welding materials and similar items issued by the Ordnance Department .....	TM 9-850
Preservation and care of seacoast defense materiel .....	TM 4-245
Seacoast artillery formations, inspections, service, and care of materiel .....	FM 4-20
<b>c. General.</b>	
Coast artillery gunners' instruction, fixed seacoast artillery, expert gunners .....	TM 4-310
Coast artillery weapons and materiel .....	TM 4-210
Coast defense .....	FM 31-10
Firing .....	FM 6-40
Seacoast artillery, service of the piece, 12-inch Mortar (fixed armament) .....	FM 4-55
Ordnance field service in time of peace .....	AR 45-30
Qualification in arms and ammunition training allowances .....	AR 755-10
Seacoast artillery Gunnery .....	FM 4-10
<b>d. Sighting and Fire Control Equipment.</b>	
Instruction guide Azimuth instrument, M1910A1 .....	TM 9-2675
Instruction guide Azimuth instrument, M1918A2 .....	TM 9-2680
Instruction guide Spotting board M3 .....	TM 9-2682
Seacoast artillery Fire control and position finding .....	FM 4-15

**91. FIRING TABLES:**

Mortar, 12-inch, M1890MI .....	FT 12-A-4
	FT 12-G-1
	FT 12-G-1, C1
Gun, subcaliber, 2.95-inch .....	FT 75-D-1

**92. ARMY REGULATIONS.**

Ordnance Field Service in Time of Peace .....	AR 45-30
Range Regulations for Firing Ammunition for training and target practice .....	AR 750-10

## INDEX

A	Page No.		Page No.
Accessories		packing	
baffle, primer flame . . . . .	104	data for estimating weight	
book, artillery gun . . . . .	104	and volume requirements . . . . .	98-99
brush, slush . . . . .	104	general information on . . . . .	97
covers . . . . .	104	marking of containers for . . . . .	99
description . . . . .	103-104	primers . . . . .	97
device, bore greasing,		projectiles	
12-inch, M4		firing, preparation for . . . . .	90
description . . . . .	104-105	general information on . . . . .	83
method of slushing bore . . . . .	105-107	table of data . . . . .	84
extractor, power for dummy		propelling charges	
projectiles . . . . .	107	base and increment . . . . .	91
pan, drip . . . . .	107	igniting powder . . . . .	91
rammer and staff . . . . .	107	sections listed . . . . .	91
scraper . . . . .	107	dummy charges . . . . .	93
tongs, shot . . . . .	107	equal section . . . . .	90
tools, firing mechanism . . . . .	110-111	marking . . . . .	91
truck, shot . . . . .	111	firing, preparation for . . . . .	91-93
wrenches . . . . .	111-112	general information . . . . .	90
Accidental firing, prevention of		subcaliber ("fixed")	
lanyard safety device, use of . . . . .	33	general . . . . .	99
safety bar, use of . . . . .	18-19	packing . . . . .	101
Active season, preparation for . . . . .	62-63	rounds . . . . .	99-101
Adapter, rear (subcaliber		Ammunition trucks, storage of . . . . .	63
materiel) . . . . .	114	Arming fuzes . . . . .	94
Adjustment		Assembly of breech mechanism . . . . .	58-60
counterrecoil springs . . . . .	49	Authorized rounds of ammunition . . . . .	81-82
mounting subcaliber gun . . . . .	117	Azimuth circle and pointer,	
(See also Inspection and		description of . . . . .	29
adjustment)			
Ammunition		<b>B</b>	
authorized rounds . . . . .	81-82	Baffle, primer flame (obturator	
care, handling, and preservation . . . . .	80	spindle), location and use of . . . . .	104
classification . . . . .	77-78	Base and increment of propelling	
deck-piercing . . . . .	77	charges . . . . .	91
dummy . . . . .	77	Base of carriage . . . . .	21
high explosive . . . . .	77	Base ring, inspection and	
target practice . . . . .	77	adjustment . . . . .	71
cleaning gas exposed . . . . .	124	Battery, failure of mortar to return	
field report of accidents . . . . .	100	fully into . . . . .	49
firing, preparation for . . . . .	82	Book, artillery gun . . . . .	104
firing table . . . . .	128	Bore	
fuzes		care of after firing . . . . .	50-51
arming . . . . .	94	method of slushing . . . . .	105-107
boresafe . . . . .	94	mortar tube, inspection and	
classification . . . . .	94	adjustment . . . . .	68
information, general . . . . .	77	scraper . . . . .	107
nomenclature . . . . .	77	Boresafe fuzes . . . . .	94
		Brake, traversing, description and	
		use of . . . . .	29

12-INCH SEACOAST MATERIEL

<b>B—Cont'd</b>	<b>Page No.</b>	<b>Page No.</b>
Breech bushing .....	13	Carriage, 12-inch mortar, M1896MI and M1896MII
Breech cover .....	104	care and preservation .....
Breech mechanism		50-67
broken or damaged parts of .....	49	data on .....
care and preservation		4-5
assembly of .....	58-60	description .....
care of after firing .....	51	21-35
cleaning and oiling .....	58	azimuth circle and pointer .....
disassembly of for cleaning .....	51-58	29
description .....	12-14	counterrecoil mechanism .....
general .....	12	24-28
principal parts .....	12-14	electrical equipment .....
inspection and adjustment .....	69-71	33
opening and closing .....	36	elevating mechanism .....
Breechblock		28-29
description .....	12	general .....
latching .....	14	21
power to rotate .....	14	lanyard attachment .....
safety bar operation .....	19	29-33
seized .....	48	recoil mechanism .....
Breechblock and breech-recess, inspection and adjustment .....	70	21-24
Brush, slush (for oiling bore) .....	104	traversing mechanism .....
Buffers, counterrecoil .....	24	29
Bushings (See <i>specific names</i> )		malfunction and correction .....
		49

**C**

Care and maintenance, sub-caliber equipment .....	118	Caution during firing of mortar .....	42
Care and preservation .....	50-67	Chart, inspection .....	67
active season, preparation for .....	62-63	Chemicals, liquid, removal of from materiel .....	125-126
ammunition .....	80	Circuit breaker (firing mechanism), description and use of .....	19
bore, care of after .....	50-51	Circuits, firing and lighting, test and adjustment .....	74
breech mechanism		Classification of:	
assembly of .....	58-60	ammunition .....	77-78
care of after firing .....	51	fuzes .....	94
cleaning and oiling .....	58	Cleaning	
disassembly of for cleaning .....	51-58	materiel affected by gas	
firing mechanism		ammunition exposed to gas .....	124
care of after firing .....	51	unpainted metal parts exposed to gas .....	124
disassembly and cleaning of .....	60	oilholes .....	62
inactive season, preparation for .....	63	Cleaning breech mechanism .....	58
lubrication and care, importance of .....	50	disassembly of for .....	51-58
lubrication instructions .....	60-62	Cleaning materials .....	65
service of mortar and carriage during inactivity .....	64	Closing breech mechanism .....	36
servicing materials .....	64-65	Compression grease cups, care of .....	62
cleaning materials .....	65	Contact clip (firing mechanism), use of .....	18
table of lubricants .....	64	Correction (See <i>Malfunction and correction</i> )	
		Counterrecoil buffers .....	24
		Counterrecoil mechanism, description of .....	24-28
		Counterrecoil springs, malfunction and correction of .....	49
		Covers for muzzle and breech .....	104
		Cylinders, recoil, description and function of .....	21-22, 24

INDEX

<b>D</b>	Page No.	Page No.
Data		
carriage	4-5	Electrical data
mortar	3-4	5
packing (weight and volume requirements)	98-99	Electrical equipment
projectile (table)	84	firing and lighting circuits
subcaliber gun (2.95-in.)	6	description of
Deck-piercing projectiles,		test and adjustment
description of	77	Electrical firing of mortar
Decontamination	125-126	46
procedure	125-126	Elevating gear cases, lubrication of
protective measures	125	61
Depressing the mortar	37-39	Elevating lock and clamp, use of
Description		21
accessories	103-104	Elevating mechanism
(See <i>under</i> Accessories for list of)		data on
carriage	21-35	description and operation
(See <i>under</i> Carriage, 12-inch mortar, M1896MI and M1896MII for components)		inspection and adjustment
fuzes	94	4
mortar	12-20	loose, cause and correction
breech mechanism	12-14	pinion and open gears, lubrication of
firing mechanism	14-19	61
general description	12	Elevating the mortar
projectiles	77-78	37
Designation of ammunition (mark, model, or "M")	78	Equal section of propelling charges
Device, bore greasing, 12-inch, M4		marking
description	104-105	91
method of slushing bore	105-107	Equalizing pipe
Disassembly		repair of
breech mechanism for		use of
cleaning	51-58	24
firing mechanism for cleaning	60	Extractor clip, use of
subcaliber gun (mounting in bore of mortar)	117	114-116
Drip pans, use of on recoil		Extractor, gun, use of
cylinder	107	116
Dummy projectiles, description of	78	Extractor, hand (subcaliber material), use of
Dummy propelling charges	93	116
		Extractor, power, for dummy
		projectiles
		107
		<b>F</b>
		Faceplate, description and use of
		12-13
		Field report of accidents
		of ammunition
		101
		Firing ammunition
		preparation for
		projectiles
		propelling charges
		82
		90
		91-93
		Firing circuit
		data on
		description
		test and adjustment
		5
		33
		74
		Firing leaf, description and use of
		18
		Firing mechanism
		broken or damaged parts of
		care and preservation
		care of after firing
		disassembly and cleaning of
		49
		51
		60

12-INCH SEACOAST MATERIEL

F—Cont'd	Page No.
Firing mechanism—Cont'd	
description .....	14-19
general .....	14-18
principal parts .....	18-19
inspection and adjustment .....	71
tools .....	110-111
Firing subcaliber gun .....	117-118
care and maintenance of after ...	118
Firing the mortar .....	46
elevating mechanism, use of in ..	28-29
equalizing pipe, use of in .....	24
firing mechanism, care of after ..	51
lanyard attachment, use of in ..	29, 32
points to be observed before .....	41
points to be observed during .....	42-46
Fittings, lubrication, painting of ...	62
“Fixed” ammunition for subcaliber practice .....	99
Frames of carriage, use of .....	21
Friction device (elevating mecha- nism), description and use of ..	28-29
Friction primer, malfunction and correction .....	48
Fuzes	
arming .....	94
boresafe .....	94
kinds, description of .....	94
marking .....	79

**G**

Gage, locating (subcaliber gun), use of .....	116
Gas check pad	
oiling	
after firing .....	44
before firing .....	41
inspection and adjustment .....	71
Gas check pad seat, inspection and adjustment .....	69
Gases, escape of, cause and correction .....	48
Guide bar (firing mechanism), use of .....	18
Guide, lubrication .....	66
Gun, subcaliber (2.95-inch) (See Subcaliber gun (2.95-inch))	
Gun book .....	104

H	Page No.
High explosive projectiles, description of .....	77-78
Hinge pin (breech mechanism), use of .....	14
Hinged collar and housing, description and use of .....	18

**I**

Identification of ammunition	
general information .....	78
lot number .....	78
mark, model, or “M” designation ..	78
Identification of lubrication points ..	62
Igniting powder .....	91
Inactive season	
preparation for .....	63
service of mortar and carriage during .....	64
Inspection and adjustment	
base ring .....	71
breech mechanism	
breechblock and breech-recess ..	70
gas check pad .....	71
obturator .....	70
obturator spindle washer .....	71
operation .....	69
rotating crank lock .....	69
rotating mechanism .....	69
split rings .....	71
translating mechanism .....	70
tray back latch .....	70
tray latch catch .....	70
electrical equipment .....	74
lighting and firing circuit .....	74
elevating mechanism .....	72
firing mechanism .....	71
information, general .....	68
lanyard safety device .....	75
mortar tube	
bore .....	68
gas check pad seat .....	69
recoil and counterrecoil	
mechanism .....	73-74
traversing mechanism .....	72-73
Inspection chart .....	67
Installing subcaliber tube	
mounting subcaliber gun .....	117
adjustment and disassembly ...	117
Instruments, sighting and fire control .....	5-6



12-INCH SEACOAST MATERIEL

O—Cont'd	Page No.		Page No.
Oilholes, cleaning	62	Primer(s)	
Oiling breech mechanism	58	electric	
Opening breech mechanism	36	description	97
Operation	36-46	malfunction and correction	47-48
breech mechanism	36	friction	
inspection	69	description	97
general remarks on	36	malfunction and correction	48
mortar		insertion of in loading mortar	46
depressing	37-39	malfunction and correction	48
elevating	37	marking of	79
firing	46	painting	121
loading	46	Projectiles	
points to be observed before	41	data, table of	84
points to be observed during	42-46	description	77-78
traversing	39-40	deck-piercing	77
subcaliber gun		dummy	78
firing	117-118	high explosive	78
loading	117	target practice	78
Organization spare parts and		general information on	83
accessories	102-113	loading	46
accessories (See under Acces-		marking	79
sories for list of)		Propelling charges	
description	103-104	base and increment	91
special uses	104-112	dummy charges	93
spare parts		equal section	90
description	102	marking	91
list of	103	general information on	90
		marking	79
		preparation for firing	91-93
		Protective measures for:	
		decontamination	125
		materiel affected by gas	124
		<b>R</b>	
		Racer (base of carriage),	
		use of	21
		Rammer and staff, description and	
		use of	107
		Receptacles for lubricants	62
		Recoil	
		measuring after firing	44-46
		measuring length of before firing	41
		Recoil and counterrecoil mechanism	
		data on	5
		description	21-24
		counterrecoil buffers	24
		cylinders	21-22, 24
		equalizing pipe	24
		recoil procedure	24
		inspection and adjustment	73-74

P

Packing	
ammunition	97
subcaliber	101
Paint(-ing)	
ammunition	79
information on and use of	120
lubricating devices	123
lubrication fittings	62
metal surfaces	122
preparing for	121-122
removing	122
Pan, drip, use on recoil cylinders	107
Pipe, equalizing (See Equalizing pipe)	
Powder chamber, swabbing after firing	44
Powder, placement of in loading mortar	46
Pressure plug seats, closing before firing	41



12-INCH SEACOAST MATERIEL

<b>T—Cont'd</b>	<b>Page No.</b>	<b>Page No.</b>
Traversing mechanism		Tray spring bolt, use of . . . . . 14
data on . . . . .	4-5	Truck, shot, description of . . . . . 111
description and operation . . . . .	29	Tube, subcaliber, installing . . . . . 117
inspection and adjustment . . . . .	72-73	(See also Mortar tube)
Traversing rollers, lubrication of . . . . .	61-62	
Traversing the mortar . . . . .	39-40	<b>W</b>
Tray and tray hinge (breech mechanism), description of . . . . .	13-14	Wedge, adapter clamp, use of . . . . . 116
Tray back latch (breech mechanism)		Weight
inspection and adjustment . . . . .	70	carriage . . . . . 4
use of . . . . .	14	mortar . . . . . 3
Tray latch catch (breech mechanism), inspection and adjustment	70	Weight markings of projectiles . . . . . 80
		Wrenches
		description . . . . . 111-112
		subcaliber materiel . . . . . 116

[ A.G. 062.11 (7-1-42)  
O.O. 461/17739 O.O. (10-8-42) ]

BY ORDER OF THE SECRETARY OF WAR:

G. C. MARSHALL,  
*Chief of Staff.*

OFFICIAL:

J. A. ULIO,  
*Major General,  
The Adjutant General.*

DISTRIBUTION:

IR 4(5); R 9(2); IBn 4(3), 9(1); IC 4(6), 9(4).  
(For explanation of symbols, see FM 21-6)