

WAR DEPARTMENT TECHNICAL MANUAL

TM 9-424

This TM supersedes OFSB 6-E-16, dated 4 Aug 42, and WDTB 9-424-1, dated 30 Oct 44. This TM supersedes portions of Ordnance Documents No. 1680, dated 1 Mar 18, and No. 1688, dated 9 Oct 12, which apply to the materiel covered in this TM; however, these Ordnance Documents remain in force until incorporated in all other affected TM's or specifically rescinded.

6-INCH
SEACOAST MATERIEL:
GUN M1900 MOUNTED ON
BARBETTE CARRIAGE M1900



WAR DEPARTMENT

26 MARCH 1945

RESTRICTED. DISSEMINATION OF RESTRICTED MATTER.

No person is entitled solely by virtue of his grade or position to knowledge or possession of classified matter. Such matter is entrusted only to those individuals whose official duties require such knowledge or possession.

(See also paragraph 23b, AR 380-5, 15 March 1944.)

WAR DEPARTMENT
Washington 25, D. C., 26 March 1945

TM 9-424, 6-inch Seacoast Materiel: Gun M1900 Mounted on Barbette Carriage M1900, is published for the information and guidance of all concerned.

[A.G. 300.7 (11 Mar 44)
O.O. 300.7/7376]

BY ORDER OF THE SECRETARY OF WAR:

G. C. MARSHALL,
Chief of Staff.

OFFICIAL:

J. A. ULIO,
*Major General,
The Adjutant General.*

DISTRIBUTION: AGF (10); ASF (2); S Div ASF (1); T of Opns (10); Def Comd (3); Sectors (3); Arm & Sv Bd (2); Tech Sv (2); SvC (10); PE "Marked for Ord O" (5); Dist O, 9 (5); Dist Br O, 9 (3); Reg O, 9 (3); Decentralized Sub-O, 9 (3); Establishments, 9, except Am (3); USMA (20).

(Refer to FM 21-6 for explanation of distribution formula.)

CONTENTS

	Paragraphs	Pages
CHAPTER 1. INTRODUCTION	1- 4	1- 4
CHAPTER 2. GUN AND CARRIAGE	5- 50	5- 59
SECTION I. Description of gun	5- 8	5- 11
II. Description of carriage	9- 18	12- 18
III. Operation	19- 25	18- 24
IV. Lubrication	26- 28	24- 30
V. Malfunctions and corrections	29- 32	30- 33
VI. Care and preservation	33- 40	33- 55
VII. Inspection and adjustment	41- 49	55- 58
VIII. Repair	50	58- 59
CHAPTER 3. SIGHTING EQUIPMENT	51- 58	60- 66
CHAPTER 4. AMMUNITION	59- 69	67- 82
CHAPTER 5. ORGANIZATIONAL SPARE PARTS AND ACCESSORIES	70-100	83-108
CHAPTER 6. SUBCALIBER EQUIPMENT	101-114	109-124
CHAPTER 7. PREPARATION OF MATERIEL FOR USE UNDER EXTREME CONDI- TIONS	115-119	125-127
CHAPTER 8. SEACOAST ARTILLERY: PRESSURE TESTING	120-124	128-129
CHAPTER 9. REFERENCES	125-128	130-133
INDEX		134-136

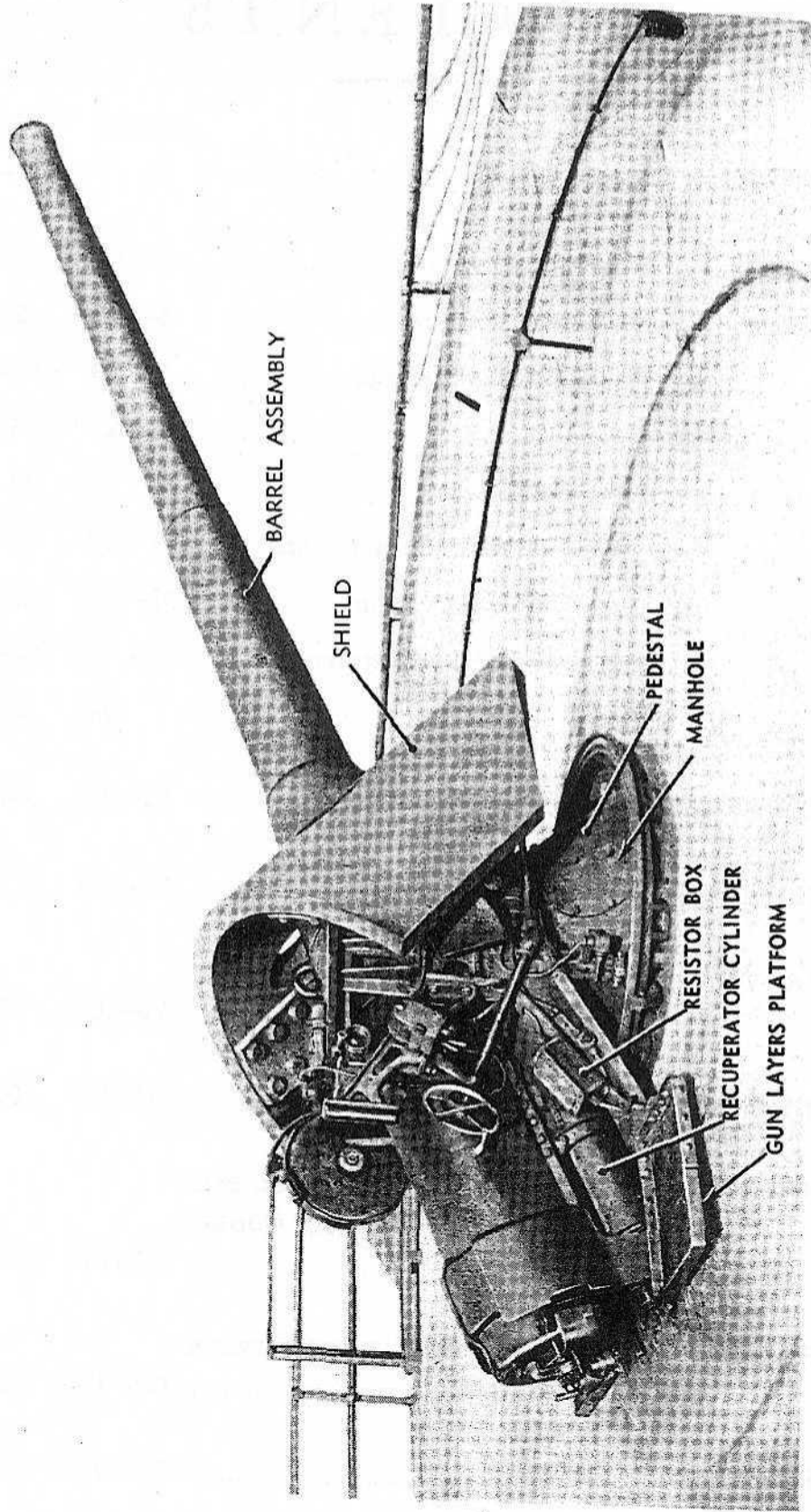

RA PD 39894

Figure 1 — 6-inch Gun M1900 Mounted on 6-inch Barbette Carriage M1900 — Maximum Elevation

RESTRICTED

This TM supersedes OFSB 6-E-16, dated 4 Aug 42, and WDTB 9-424-1, dated 30 Oct 44. This TM supersedes portions of Ordnance Documents No. 1680, dated 1 Mar 18, and No. 1688, dated 9 Oct 12, which apply to the materiel covered in this TM; however, these Ordnance Documents remain in force until incorporated in all other affected TM's or specifically rescinded.

CHAPTER 1 - INTRODUCTION**1. SCOPE.**

a. This manual is published for the information and guidance of the using arms and services.

b. In addition to a description of the Gun M1900 and Barbette Carriage M1900, this manual contains technical information required for the identification, use, and care of the weapon, ammunition, and accessory equipment.

c. In all cases where the nature of repair, modification, or adjustment is beyond the scope or facilities of the unit, the responsible ordnance service should be informed so that trained personnel with suitable tools and equipment may be provided, or proper instructions issued.

d. Instructions for the care and use of on-carriage sighting and fire control equipment authorized for use with this weapon are included. Off-carriage sighting and fire control equipment are not covered in this manual; for instructions on their care and use, refer to FM 4-15, and Technical Manuals on specific items of fire control and sighting equipment.

e. Technical Manuals, Field Manuals, Firing Tables, Standard Nomenclature Lists, and other publications pertaining to materiel described herein are listed in chapter 9.

2. RECORDS.**a. Artillery Gun Book.**

(1) The Artillery Gun Book (O.O. Form 5825) is used for the purpose of keeping an accurate record of the materiel. It must always remain with the materiel. The book is divided as follows: Record of assignment; battery commander's daily gun record; inspector's record of examination. This book should be in the possession of the organization at all times, and its completeness of records and its whereabouts are the responsibility of the battery commander. It must also contain date of issuance of the materiel, by whom used, and the place where issued. If a new gun is installed on the carriage, all data recorded in the old book with reference to sights, mounts, etc., must be copied into the new book before the old book is relinquished. If a gun book is lost, it should be replaced at once and all entries brought up to date. Additional copies may be obtained by requisition to Office, Chief of Ordnance, Office Service Division, Supply Branch, Attention: SPOGA-5, Washington 25, D. C., on WD AGO Form No. 445.

Introduction

(2) Complete instructions on how to make entries in the Artillery Gun Book are contained therein. It is absolutely essential that the gun book entries be kept complete and up-to-date. In order to facilitate proper maintenance of the cannon and its related materiel (that is, carriage, recoil mechanism, and associated fire control equipment) and to avoid unnecessary duplication of repairs and maintenance, the following additional entries are to be made in the gun book:

(a) A record of complete Modification Work Orders. This record should show the date completed and bear the signature of the officer or mechanic responsible for completion of the modification.

(b) A record of seasonal changes of lubricants and recoil oil in sufficient detail to prevent duplication and afford proper identification by the inspector.

(3) The estimated accuracy life for this gun is 1,250 rounds.

b. **Field Report of Accidents.** When an accident involving ammunition occurs during practice, the incident will be reported as prescribed in AR 750-10 by the ordnance officer under whose supervision the ammunition is maintained or issued. Where practicable, reports covering malfunctions of ammunition in combat will be made to the Chief of Ordnance, giving the type of malfunction, type of ammunition, the lot number of the complete rounds or separate loading components, and condition under which fired.

c. **Unsatisfactory Equipment Report.** Suggestions for improvement in design, maintenance, safety, and efficiency of operation prompted by chronic failure or malfunction of the weapon, spare parts, or equipment should be reported on WD AGO Form No. 468, Unsatisfactory Equipment Report, with all pertinent information necessary to initiate corrective action. The report should be forwarded to the Office, Chief of Ordnance, Field Service, Maintenance Division, through command channels in accordance with instruction No. 7 on the form. Such suggestions are encouraged in order that other organizations may benefit. If WD AGO Form No. 468 is not available, refer to TM 37-250 for list of data required on Unsatisfactory Equipment Reports.

d. **Battery Emplacement Book.** A Battery Emplacement Book will also be kept for each battery. For information on care of this book, and entries to be made therein, refer to TM 4-245.

3. CHARACTERISTICS.

a. The 6-inch Gun M1900 is a manually operated rapid fire gun with a maximum range of 17,000 yards at 20 degrees elevation. The gun fires separately loaded armor-piercing or high-explosive ammunition and is normally fired electrically by means of an *electric* type primer and a magneto. If necessary, it can be fired manually by a lanyard, using a *friction* type primer. Safety devices are provided to prevent premature discharge of the gun.

Introduction

b. A range drum and an azimuth circle are provided on the carriage for directing the gun. Both elevation and traverse are manually operated.

c. The gun recoils in a cradle which carries the trunnions. The recoil is absorbed by springs and a hydraulic recoil cylinder. The recuperator springs return the gun to battery.

d. The gun is mounted on a barbette carriage. A steel shield 4½ inches thick protects the front of the gun against enemy fire and bomb fragments (fig. 1).

4. TABULATED DATA.

a. Gun M1900.

Type of barrel	Built-up
Type of breech	Lever-pull
Type of breechblock (interrupted thread)	Four-sector parallel
Caliber	6 in.
Length of bore	50 cal
Total length (muzzle to breech face)	310.4 in.
Length of barrel	302.9 in.
Length of rifling	254.14 in.
Rifling (original tube):	

Twist, right-hand, semi-cubial parabola..... Starts one turn 50 cal and increases to one turn 25 cal

	Prior to 1918	After 1918
Number grooves and lands	36	54
Width of lands	0.15 in.	0.14 in.
Width of grooves	0.3736 in.	0.2091 in.
Depth of grooves	0.04 in.	0.05 in.

Rifling (liner):

Twist, uniform, right-hand	One twist in 25 cal
Number of grooves and lands	76
Width of lands	0.117 in.
Width of grooves	0.131 in.
Depth of grooves	0.05 in.

Weight of barrel	19,114 lb
Range	17,000 yd

Muzzle velocity:

105-pound projectile	2,800 fps
108-pound projectile	2,600 fps

Travel of projectile in barrel	256.325 in.
Center of gravity (distance from muzzle)	210.15 in.

b. 1.457-inch Subcaliber Gun.

Over-all length of tube	72.85 in.
Weight of gun and adapters	138 lb

CHAPTER 2 – GUN AND CARRIAGE**Section I****DESCRIPTION OF GUN****5. GUN BARREL.**

a. The gun barrel of M1900 is of the built-up type, constructed of hoops, jacket, tube (or tube with liner) recoil band, and hinge plate, and is provided with two keys or ribs to prevent rotation of the gun in mount.

b. The breech end of the barrel is constructed to form a threaded recess in which the breech bushing is screwed.

c. The breech bushing acts as the locking member for the breech-block.

d. The hinge plate is provided with lugs for the breechblock carrier hinge pin.

e. The recoil band at the breech end of the barrel has a lug to which the recoil piston rod is attached. This rod carries a yoke to the ends of which the counterrecoil spring rods are bolted.

f. The tube is bored to form chamber and bore. The seat for the gas check pad is at the rear of the powder chamber. The powder chamber at the front narrows to form the centering slope which guides the projectile into the forcing cone. The forcing cone is tapered to guide the projectile rotating band into the rifling. The bore is rifled throughout.

g. The tubes for M1900 have an estimated life of 800 rounds. On guns having the original tube (not relined), the rifling is semi-cubical parabola and not uniform. On guns which have been relined, the rifling is usually uniform.

h. In cases where the seats for the gas check pads have been enlarged, a marking place is fastened to the hinge plate, which states the extent of enlargement in size and the advance of the gas check seat in the tube. These guns require special rings, gas check pads, and spindle disk, and some may be found to have an enlarged obturator spindle.

i. The breech hinge plate is stamped with the model of gun, name of manufacturer, and year of manufacture.

j. The muzzle face is marked with the model of gun, name of manufacturer, and year of manufacture. The weight of the complete gun is indicated and, if it has been relined, the year of relining is marked. The muzzle face is scored with witness lines for use of the muzzle bore sight during orientation of the gun.

Gun and Carriage

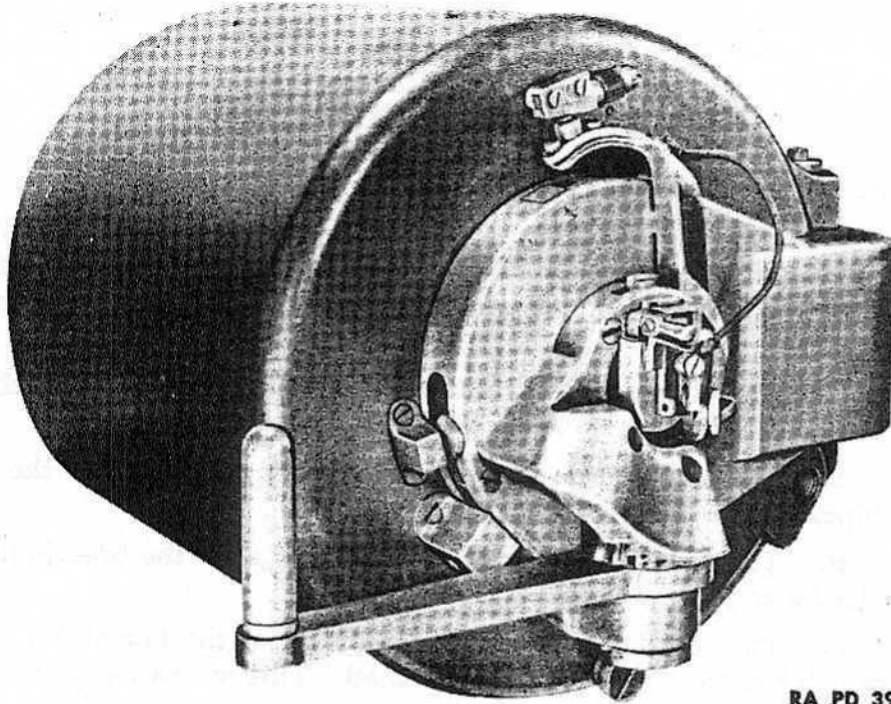

RA PD 39857

Figure 2 — Closed Ready To Fire

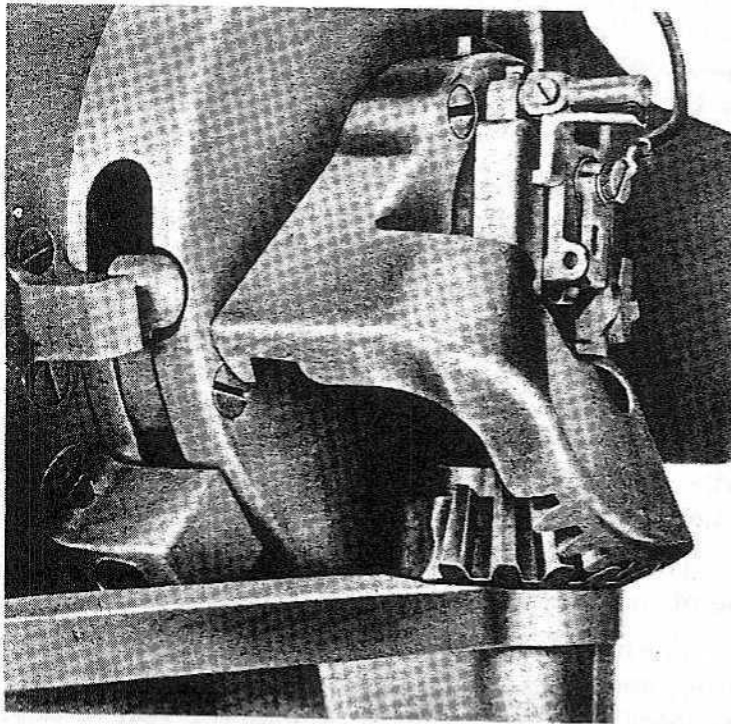

RA PD 39858

Figure 3 — Closed Position — Close-up of Segment Gear

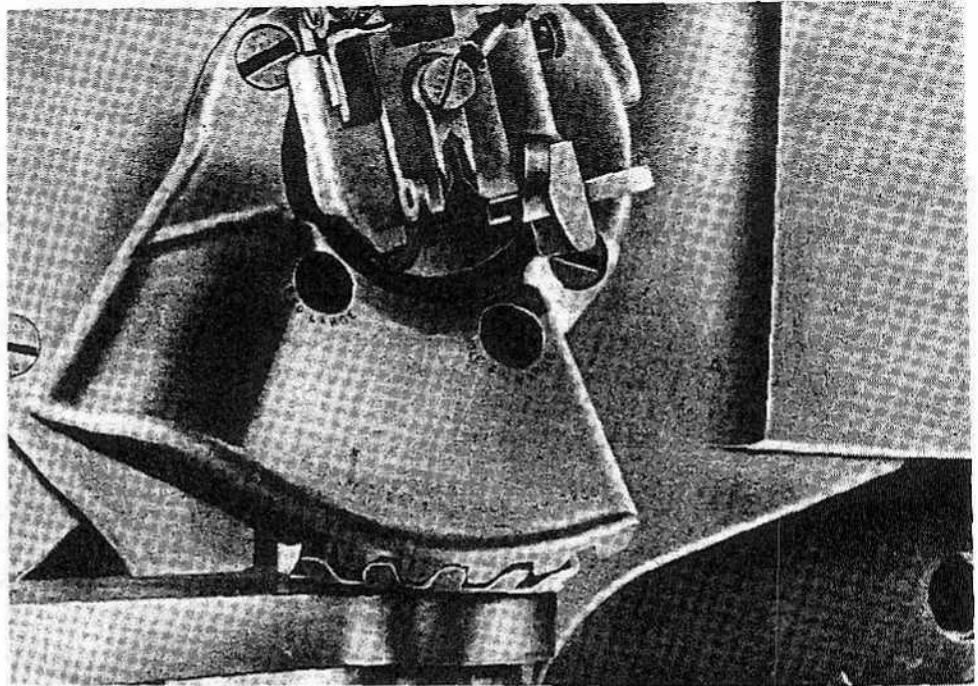

RA PD 39859

Figure 4 – Segment Gear Rotating Close-up

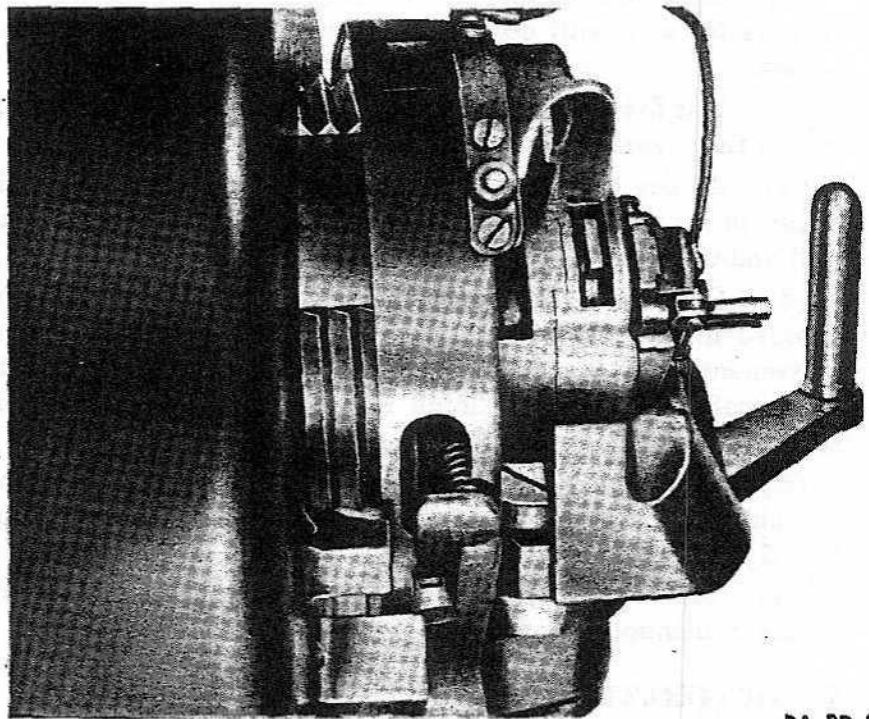

RA PD 39856

Figure 5 – Tooth on Operating Lever Gear Pushing Breechblock

Gun and Carriage

6. BREECH MECHANISM M1900 (figs. 2 and 3).

a. The breech mechanism is of the lever-pull type with a four-sector interrupted parallel thread breechblock. When the breechblock is opened by the operating lever, three operations are performed.

(1) The first movement of the lever (fig. 4) rotates the breechblock until stopped by the breechblock stop. At the same time the firing mechanism slide is moved away from the firing lever thus preventing the gun from being fired when the breech is not locked. At this point, the threaded sectors of the breechblock are disengaged from the threaded sectors in the breech bushing, and the translating teeth of the pinion start to engage the translating teeth on the gear segment (fig. 12).

(2) Further movement of the lever draws the breechblock to the rear until the stop flange strikes the bottom of the stop groove in the carrier (fig. 5). As the breechblock reaches the end of translation to the rear, the inner end of the latch bolt slides down the inclined groove on the breechblock pallet, and the outer end of the latch bolt is withdrawn from the latch bolt seat (fig. 13).

(3) Continuing the pull on the lever draws the breechblock carrier away from the gun (fig. 14) and, as the latch lever clears the tripping stud, the latch bolt is forced by the latch lever into the well in the breechblock, locking the breechblock to the carrier.

b. To Close the Breech.

(1) Grasp the handle of the lever and swing to the left and forward as far as it will go, which is parallel to the breech face of the carrier.

(2) The first movement swings the breechblock carrier against the face of the breech.

(3) As the carrier strikes the face of the gun, the latch lever is forced in by the tripping stud, which draws the latch bolt out of the well and unlocks the breechblock from the carrier.

(4) Continued movement of the lever translates the breechblock forward until it is stopped by the breechblock stop. The forward movement of the breechblock causes the inclined surface of the breechblock pallet to force the latch bolt outward and into the latch bolt seat, locking the carrier to the face of the gun.

(5) The final movement of the lever forward rotates the breechblock until the breechblock stop locks it in the firing position (fig. 2).

(6) The lever movement which opens or closes the breech is one continuous motion.

7. OBTURATION.

a. Obturation is the sealing of the breech to prevent the escape of combustion pressure to the rear.

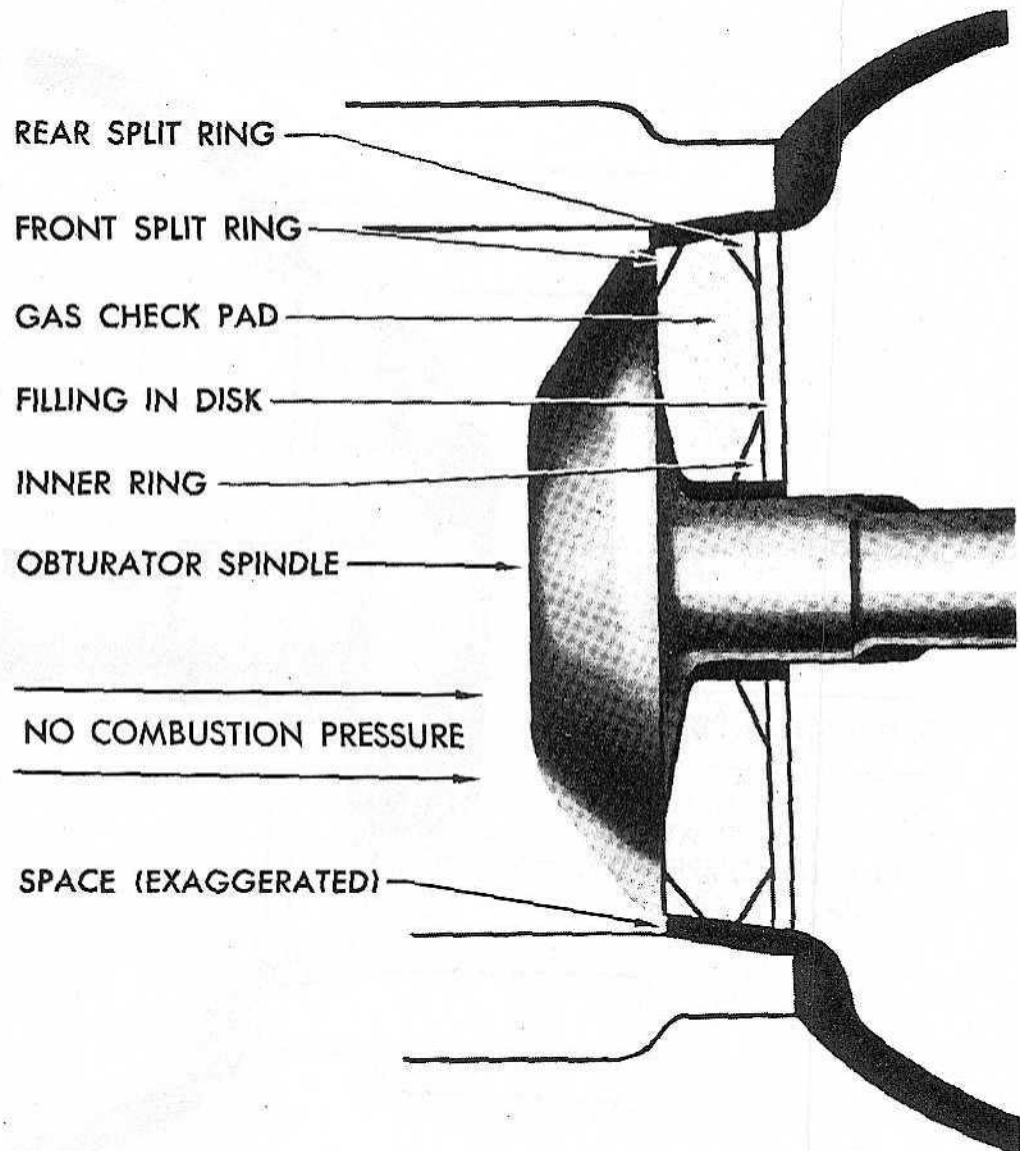
Gun and Carriage

RA PD 95214

Figure 6 – Obturator in Normal Position

b. When the breech is closed, the gas check pad and steel split rings enter the slightly tapered gas check seat in the barrel (fig. 6). When the gun is fired, the obturator spindle is forced back by the pressure of the expanding gases, thereby compressing the gas check pad and expanding the split rings (fig. 7). This action effectively seals the breech. After firing, the split rings and gas check pad resume their original position and the breech may be opened. A small split ring is also used to seal the obturator spindle hole in the gas check pad. The filling-in disk serves as a bearing washer to eliminate friction between gas check pad and breechblock. This is neces-

Gun and Carriage

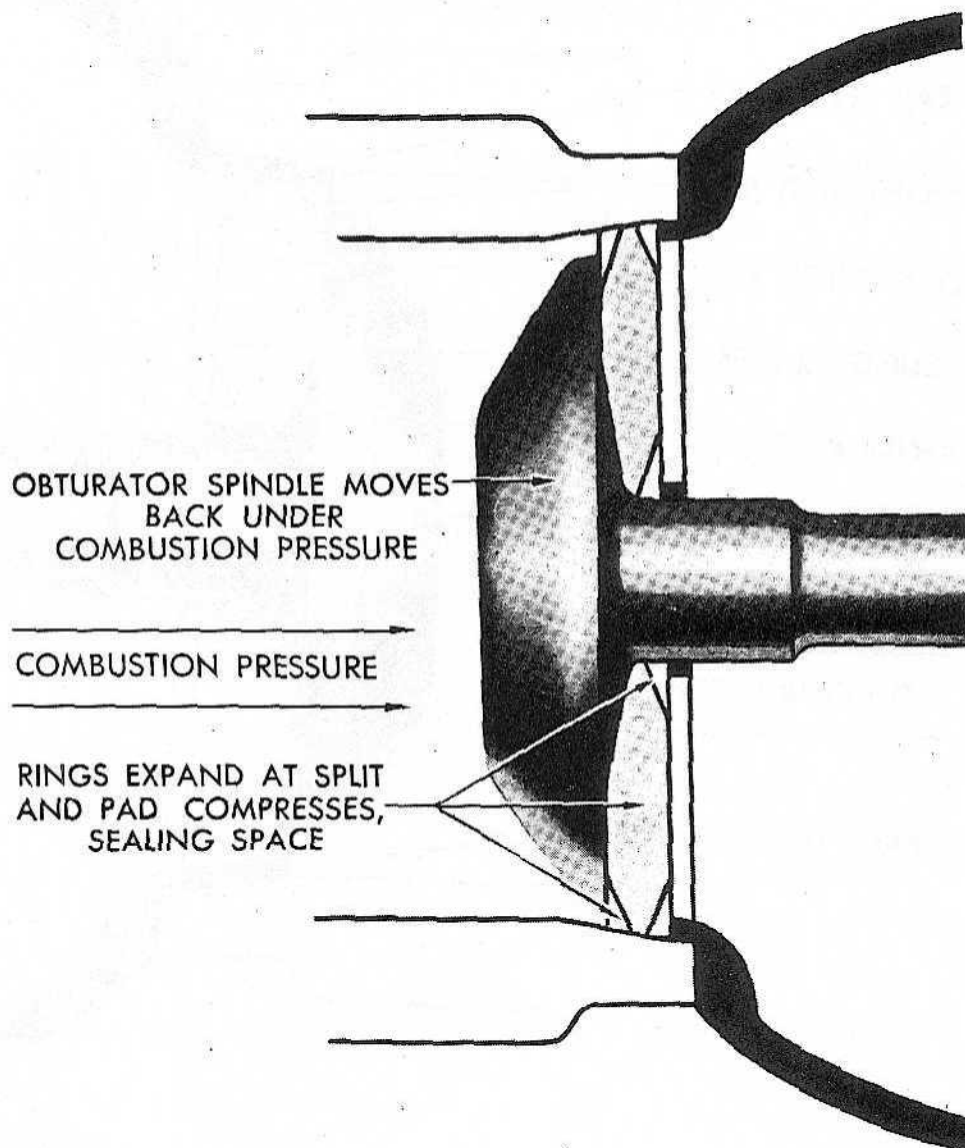

RA PD 95129

Figure 7 — Obturator in Firing Position

sary as the breechblock rotates while the obturator spindle, which is keyed to the breechblock carrier, does not.

c. A central bore in the obturator spindle forms a chamber for the primer and a vent for the primer flame. Threaded holes in the mushroom head of the spindle are used to attach plugs used in pressure testing, and are plugged with screws to prevent burning the threads when pressure plugs are not used. Holes are also provided in the head for a spanner wrench, which is sometimes necessary for the removal of the obturator spindle.

Gun and Carriage

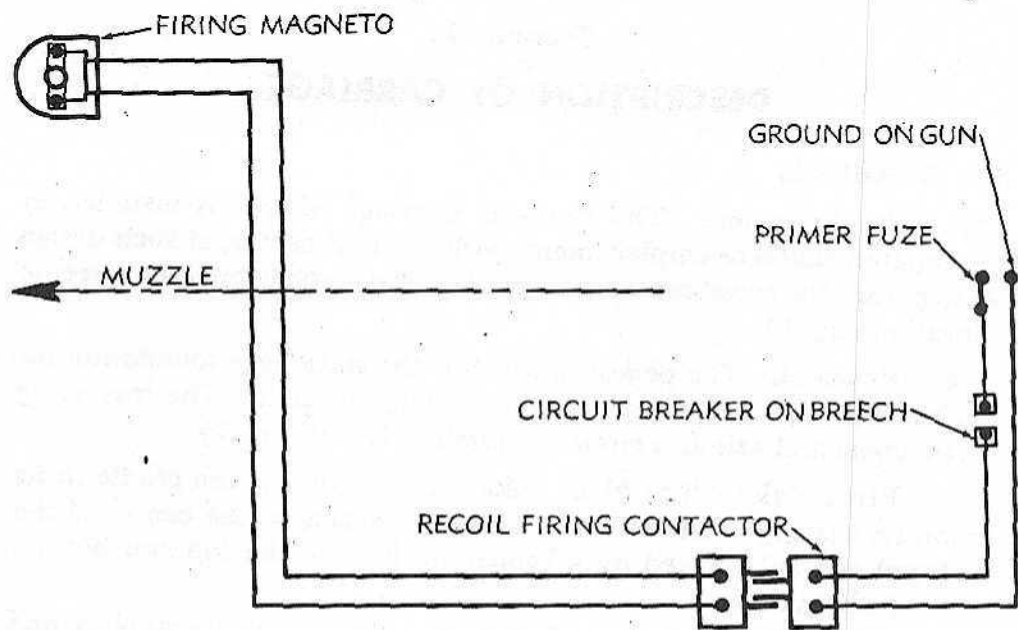

Figure 8 - Firing Circuit Wiring Diagram

RA PD 95157

d. The spindle (fig. 20) has an annular groove which engages the yoke of the firing mechanism to hold the latter in place. Back of the groove, the spindle is threaded to take the spindle nut which holds the spindle ball washer in place.

8. FIRING MECHANISM.

a. The firing mechanism (fig. 22) for the Gun M1900 is intended for use with either electric or friction primers. It consists of the following parts (fig. 40): slide, slide catch, slide housing yoke pin, ejector, firing leaf, contact clip, safety bar, firing cable, circuit breaker contact, circuit breaker housing, and circuit breaker housing bracket.

b. The gun cannot be fired unless the breech is fully closed and locked.

(1) It cannot be fired with the lanyard for as soon as the breech-block starts to rotate in closing, the safety bar enters the groove in the side of the firing leaf, preventing movement of the leaf to the rear.

(2) It cannot be fired electrically because the firing circuit is not completed until the breech is fully closed and locked.

(3) The primer which resembles a blank rifle cartridge with a knob-ended wire protruding from the base, is inserted into primer chamber of the obturator spindle.

(4) When firing by lanyard, the firing leaf is pulled back and pulls the wire of the primer rearward. This action fires the friction primer. When fired electrically, the closing of the breech completes the circuit and the primer merely awaits the electrical impulse from the magneto.

c. **Firing Circuit.** The gun is fired electrically by the magneto which is mounted on the traversing handwheel bracket.

Gun and Carriage

Section II**DESCRIPTION OF CARRIAGE****9. GENERAL.**

a. **Emplacement.** The Barbette Carriage M1900 is installed in a prepared concrete emplacement, with a raised center, of such design as to permit the recoil mechanism to clear the emplacement at extreme elevation (fig. 1).

b. **Pedestal.** The pedestal, which is the stationary foundation for the pivot yoke, is bolted to the concrete emplacement. The traversing wormwheel and azimuth circle are mounted on it (fig. 1).

c. **Pivot Yoke.** The pivot yoke, which supports the cradle in its trunnion bearings, rests on a roller thrust bearing in the center of the pedestal and is balanced by a bronze bushing at the top and bottom of the pedestal.

d. **Recoil Mechanism and Cradle.** The recoil mechanism and cradle consist of the following assemblies. The cradle, a large casting in which the gun slides for recoil and counterrecoil; the cradle trunnions and bearings for elevating or depressing the gun; the elevating rack for the control of elevation or depression; the recoil cylinder for slowing the gun to a gradual stop in recoil and counterrecoil; and the recuperator springs for slowing the gun in recoil and returning the gun to battery in counterrecoil.

e. **Elevating Mechanism.** Elevation or depression is by manually operated handwheel (fig. 9). The elevating mechanism is mounted on the left side of the yoke. The carriage is elevated through a worm, wormwheel, and pinion gear operating on the elevating rack, which is mounted on the cradle to elevate or depress the gun. The trunnions are situated at the center of gravity to balance the gun and so eliminate the need for a brake.

f. **Traversing Mechanism.** The carriage is traversed manually (fig. 10) through a worm, wormwheel, and pinion gear to the traversing wormwheel on the face of the pedestal. The traversing handwheel is mounted on the right side of the carriage. The carriage may be traversed continuously through 360 degrees (6,400 mils). In some cases, stops are employed on individual guns after emplacement to limit the field of fire.

g. **Electrical System.** The electrical system consists of the lighting circuit and the firing circuit.

10. PEDESTAL.

a. The pedestal (fig. 1) is in the general form of the lower part of a cone, terminating with a cylindrical upper section and a flanged base, which is drilled for mounting bolts. Four covered manholes

Gun and Carriage

are provided for cleaning the interior and to give access to the 360-degree electrical contact ring. The joints between manhole covers and pedestal are kept watertight by means of gaskets.

(1) The extension of the cylindrical part is finished to form a seat for the traversing wormwheel.

(2) An annular boss in the bottom of the pedestal forms a bearing for the lower end of the pivot yoke. The upper cylindrical part of the pedestal maintains the pivot yoke in a vertical position.

(3) The weight of the revolving parts is supported by a plain roller thrust bearing between the pivot yoke and the annular bore on the pedestal base.

11. PIVOT YOKE.

a. The pivot yoke has two vertical prongs which bear the trunnion beds for the trunnion bearings and cradle. The shield supports are fitted into finished recesses in the outer faces of the prongs. These supports are also bolted to the prongs of the pivot yoke. Annular projections on the pivot yoke prevent entry of water into the pedestal bearings. The ends of the cored hole in the stem are closed with plugs. The traversing gear case and the platform brackets are bolted to the prongs. Two oilholes are provided in the pivot yoke for oiling the upper pedestal bearing, and an oil pipe leads from a third hole to the thrust bearing at the lower end of the pivot yoke.

12. RECOIL MECHANISM AND CRADLE.

a. **Cradle.** The cradle is bored to receive the gun. Oil grooves in liners connected to six oilholes in the cradle and two in the front liner insure proper lubrication. Near the front end are the elevation trunnions which are supported in the pivot yoke. On the top of the cradle is a lifting ring. The shoulder guards and elevating rack are attached to the cradle. Underneath the rear portion and forming part of the cradle are the recoil cylinder and two recuperator spring cylinders.

b. **Recoil.** The recoil cylinder holds 3 gallons of oil. It has a liner cap which is screwed to the liner in which three throttling grooves are cut. The liner and liner cap are held in place by the rear cylinder head. A counterrecoil buffer is provided in the front end of the recoil cylinder. The rear end of the cylinder is closed with a head, in which are filling and drain holes (figs. 41 and 44) closed with screw plugs, and the stuffing box with its gland and follower. The piston consists of a liner screwed on the front end of the piston rod, which is attached by front and rear nuts to the recoil band (fig. 42). The recuperator spring yoke is carried on the piston rod in rear of the recoil band and is secured between rear nut and band.

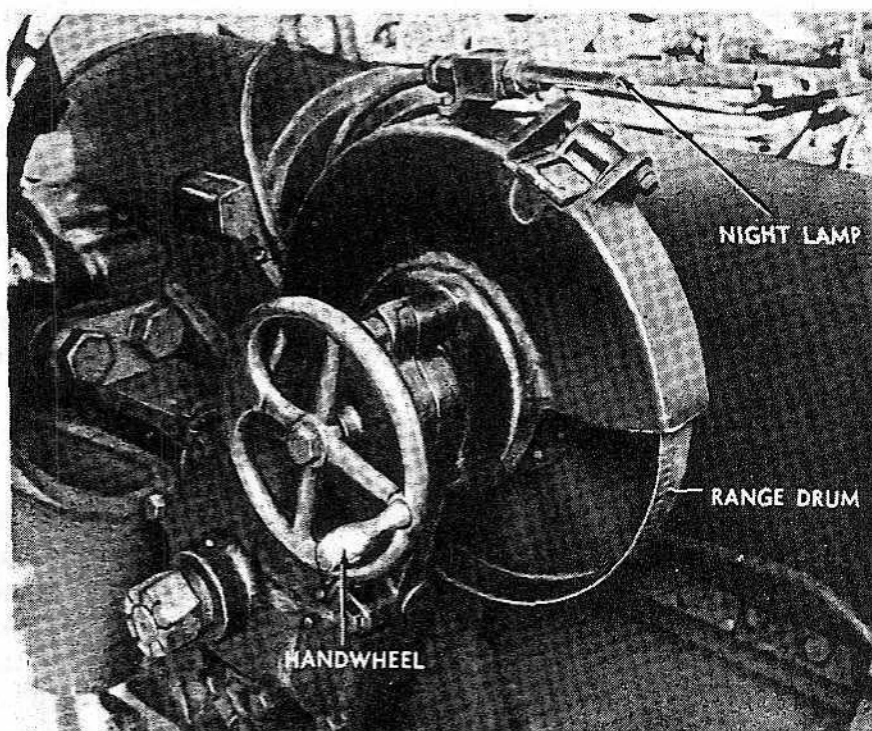
Gun and Carriage

RA PD 39896

Figure 9 – Range Drum and Elevating Handwheel M1900

c. **Recuperation.** The recuperator spring cylinders are prolonged to the rear by extensions and in each is a spring rod, the rear end of which is attached to a yoke secured in the rear of the recoil band (fig. 42). The head of each spring rod rests on a column of four springs, which are rested in the spring cylinder. The two smaller ones are carried in a stirrup that telescopes within the exterior two. Each of the two springs of the same diameter is parted by a separator. The length of the spring rod should be adjusted (fig. 43) so as to return the gun into battery at the maximum angle of elevation without shock, but in no case should the head of the rod protrude from the front end of the cylinder, which is open.

d. **Recoil and Counterrecoil System.** The action of the gun is as follows: When fired, the gun recoils to the rear about 15 inches in the cradle, carrying with it the recoil piston and recuperator springs rods; thereby, compressing the recuperator springs. A small portion of the energy of the recoil is absorbed in compressing the springs, but the greater portion is absorbed by the resistance which the liquid offers to being forced through the openings formed by the throttling grooves. The depths of the grooves are proportioned so that the areas of the openings, varying with the position of the piston during recoil, will be such as to produce a constant resistance, assisted by the recuperator springs, throughout the length of recoil. The counter-

Gun and Carriage

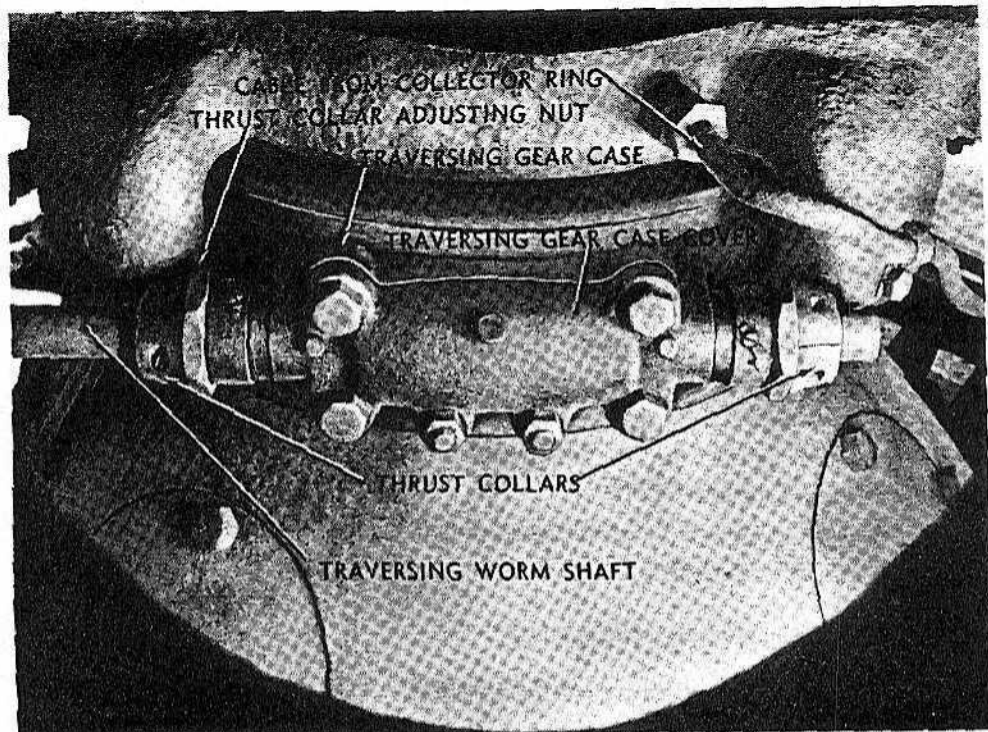

RA PD 39900

Figure 10 — Traversing Worm Housing M1900

recoil buffer or plunger is tapered to provide resistance to control the motion of the gun during its return to battery and finally bring it to rest when the piston reaches the front end of the cylinder.

13. ELEVATING MECHANISM AND RANGE DRUM (fig. 9).

a. **Elevating Mechanism.** An elevating bracket, bolted to the left platform bracket, contains the elevating gear. By means of the elevating handwheel, movement is communicated to the cradle through action of the pinion on the elevating rack. The elevating wormwheel is assembled between two other disks which bear on its sides, in such a manner that the pressure between the wheel and disks may be varied by means of a nut on the outer end of the elevating pinion shaft. This nut should be tightened sufficiently to provide enough friction to enable the gun to be elevated and yet permit slippage before any injurious strain is brought upon the elevating wormwheel and worm. Nine hundred pounds applied at the muzzle should slip the friction.

b. **Range Drum (fig. 9).** The range drum mechanism rack is bolted to the upper end of the elevating rack and meshes with the pinion. Motion of the pinion rotates the drum, to the outer cylindrical surface of which the graduation ring is attached. A spring

Gun and Carriage

keeps the face of the pinion teeth in contact with those on the rack, thus eliminating backlash.

(1) The inner edge of the ring is graduated in yards for sub-caliber range, the outer edge in yards for service range, and between these two scales the ring is graduated in degrees of elevation. The degree marks on the elevating scales are determined by the use of a clinometer supported by a rest placed in the muzzle of the gun after gun is mounted upon the carriage. *NOTE: Some range drums have been modified so that calibration is in mils.* When so graduated, height of site does not affect scale.

(2) As the ranges corresponding to different angles of elevation above the horizontal depend upon the height at which the gun is mounted above sea level, the range scale must be graduated after mounting. *This should never be done except under the supervision of the Ordnance Department.*

(3) A range pointer is attached to the range drum bracket and a shoulder guard is attached to the cradle and spring cylinder head.

14. TRAVERSING MECHANISM.

a. The traversing mechanism is located on the right side of the pedestal. Six oilholes are provided for oiling the bearing of the traversing wormwheel through the top of the pedestal. The traversing wormwheel is enclosed in a two-part gear case and bolted to the pivot yoke (fig. 10).

b. Beneath the wormwheel is the friction band. The friction between the friction band and wormwheel is adjusted to enable the gun to be traversed without slipping and yet permit slipping in case undue strain is brought on the teeth of the wormwheel.

c. The traversing worm shaft is assembled with its worm in the traversing gear case in front of the pedestal (fig. 10). At both sides of the worm it is supported in bearings formed by the traversing gear case and cover. Two ball thrust bearings, encased in collars, bear on either side of the traversing worm and transmit the thrust to the worm casting. Concave and convex washers are provided between the worm casing and the ball bearing to equalize the thrust. Between the ball bearing thrust collar and the traversing worm shaft is a split collar and a split thrust collar nut. Any excessive end play may be taken up by the thrust collar nuts. The azimuth circle is bolted to the base of the pedestal with the vernier and pointer attached to and traversing with the pivot yoke (fig. 11).

d. Near its rear end, the traversing shaft is supported by a bearing attached to the shoulder rest. On the rear end of this shaft is the traversing handwheel.

e. When necessary to control amount of traverse for any particular emplacement, traverse stops bolted to the pedestal limit the

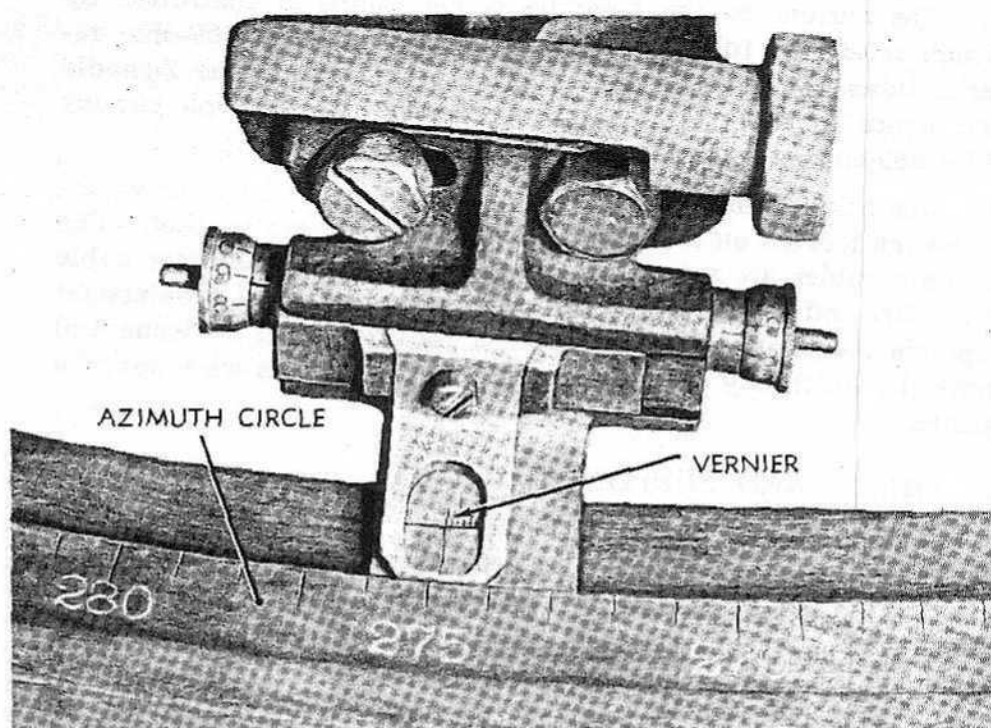
Gun and Carriage

RA PD 39899

Figure 11 – Traversing Vernier M1900

traverse right or left by contacting the stop arm bolted to the lower side of the left platform bracket.

f. Shoulder guards are bolted to cradle and spring cylinder heads on each side of the gun to protect gunners from injury during recoil and counterrecoil.

g. A shoulder rest is attached to the platform bracket on the right (traversing) side of the gun.

15. LIGHTING SYSTEM.

a. The current for lighting is obtained from the emplacement mains through a leaded and armored twin conductor cable which enters through the bottom of the pedestal. Contact clips connected to the two wires transmit the current to two contact rings attached to the pivot yoke, thus permitting the mount to be traversed 360 degrees. From these rings the power is distributed to 8-candle power lamps, one at the azimuth index and the other at the range scale; and to 2-candle power lamps on the telescopic sight, one to illuminate the cross wires and one to illuminate the deflection scale. There is also an engineer's plug box on the top of the left platform bracket for a portable lamp. All lamps are 110 volts or 220 volts, depending on the voltage of the emplacement.

Gun and Carriage

b. The current to the 8-candle power lamps is controlled by 124-ohm resistance tubes for 110-volt circuits and by 269-ohm resistance tubes for the 220-volt circuits; the current to the 2-candle power lamps by 410-ohm resistance tubes for the 110-volt circuits and by 889-ohm resistance tubes for the 220-volt circuits.

c. The azimuth and elevation lamps are controlled by the watertight switch located on the outside of the left platform bracket. The sight light cables are spliced to the end of a three-conductor cable at the other end of which is a receptacle plug to fit into a watertight receptacle plug box. The telescope is provided with a mechanical dimmer by which any desired illumination of the cross wires may be obtained.

16. SHIELD AND SUPPORTS.

a. The cylindrical shield of the 4½-inch armor plate is mounted with its axis inclined 40 degrees to the horizontal in order to provide deflecting surface to enemy fire. It weighs 10,418 pounds and is pierced with a gun port and two sighting holes. The sighting hole on the left side was used when the mount was equipped with a telescopic sight on each side. The left sight has been discarded. The shield is attached to the sides of the pivot yoke by two supports.

17. GUNNER'S PLATFORMS.

a. Platforms for the gun pointer and setter are mounted on each side of the gun.

18. LOADING TRAY.

a. In cases when hand loading is undesirable, the loading tray is used.

Section III

OPERATION

19. PREPARATION FOR FIRING.

a. *Bore Cleaning and Inspection.* Remove the breech and muzzle covers; inspect bore and chamber to be sure no foreign material has accumulated. If dirty, clean with dry-cleaning solvent and wipe dry. Normally, the bore and chamber should be wiped dry or cleaned to remove the coating of oil applied after the previous firing.

b. *Breech and Firing Mechanism Inspection.* Open and close the breech and note action. If operation is sluggish or stiff, determine cause and correct condition (par. 29). With the breech closed, pull down the firing slide latch bolt and move the slide to be sure it

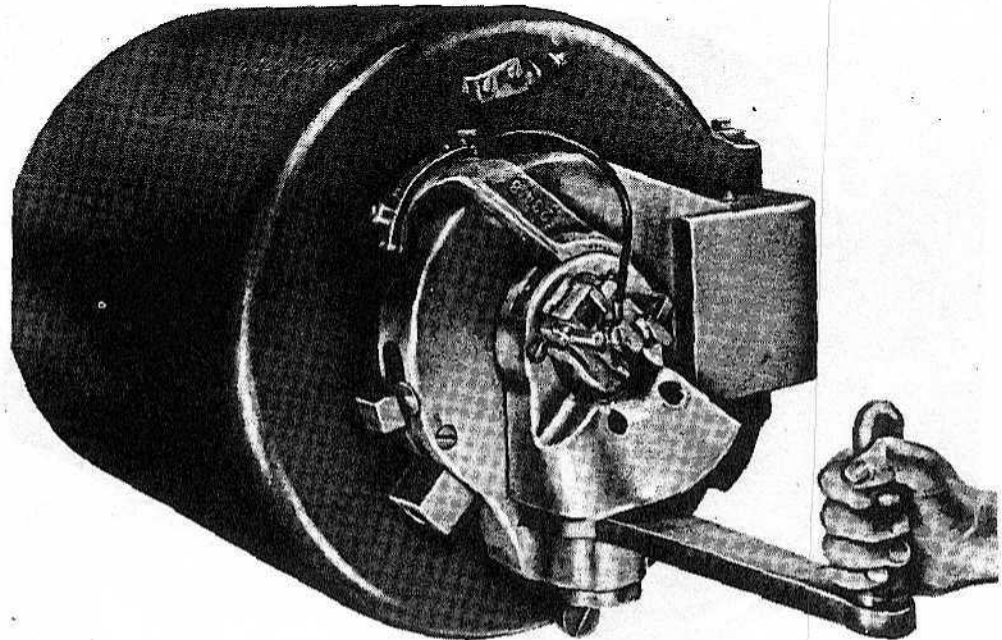

RA PD 39860

Figure 12 – Operating Lever Pulled To Turn Breechblock

operates freely. The breechblock and breech ring threads should be clean. Wipe the gas check pad, clean, and apply a thin film of oil as prescribed by WDLO 9-424.

c. Electrical Contact Check. Before firing, check completeness of the firing circuit. The circuit may be tested with a test lamp or by firing a primer (par. 49).

d. Ammunition Preparation.

(1) Projectiles to be fired should be prepared beforehand (par. 65) and placed in racks provided.

(2) Verify type, weight, and lot number of projectile.

(3) Remove rope grommet and inspect rotating band. Remove any burs with file.

(4) Wipe projectile with clean, dry wiping cloths. It is important that projectiles be perfectly clean and free of sand and dirt.

(5) Projectiles equipped with base-detonating fuzes will normally be received fuzed for firing. Projectiles equipped with point-detonating fuzes will be normally received unfuzed and will be fuzed as required in the following manner:

(a) Remove the eyebolt lifting plug from the projectile. Do not remove eyebolt until fuze is to be installed. The eyebolt plug is provided as a lifting device, and also as a plug to keep out foreign matter.

(b) Inspect fuze cavity and threads. They should be freed of any foreign matter that could interfere with the proper assembly of the fuze.

Gun and Carriage

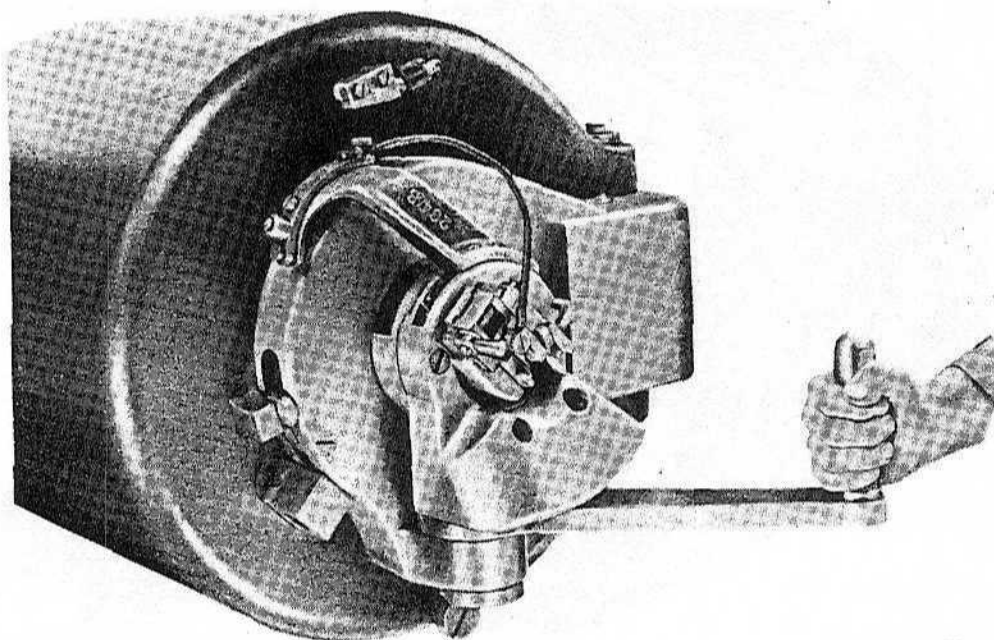

RA PD 39861

Figure 13 – Operating Lever Translating Breechblock

(c) Insert the fuze, being careful that it is fitted with its felt or rubber washer, and screw it in by hand.

(d) Screw up the fuze with the fuze wrench, but without using force.

(e) If there is any difficulty in screwing in the fuze, it should be removed and another one inserted. If the same trouble is experienced with a second fuze, the shell should be rejected.

(f) Set fuze to "DELAY" or "SQ" (superquick) as directed and described in paragraph 66.

(g) For further information and instructions on ammunition, see chapter 4.

(6) All powder charges, except the charge for the next succeeding round, will be kept in their containers. The powder charge for any round will not be brought into the gun emplacement until the preceding round has been fired. Instructions for removal of charges from containers and preparations for firing are given in paragraph 65.

(7) Previous to firing, each of the primers to be used is to be inserted in the obturator spindle to test each primer for proper fit.

e. Recoil Oil Checking. Depress the gun to zero degree (0.0 mil), remove recoil cylinder filling plug (fig. 44), and note if the cylinder is completely filled.

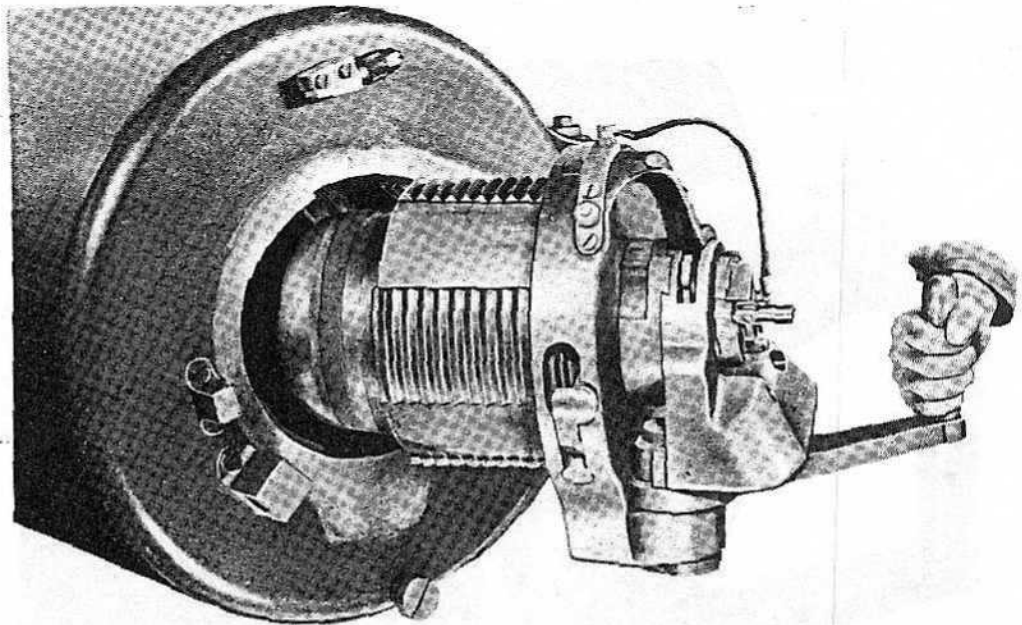

RA PD 39862

Figure 14 — Breechblock Starting To Swing on Carrier

20. TO TRAVERSE.

a. The mount is traversed by turning the handwheel of the mechanism on the right side. When tracking, the gun pointer will match the azimuth reading (fig. 11) with plotting room supplied data. For operation of sighting and fire control equipment, refer to chapter 3.

21. TO ELEVATE OR DEPRESS GUN.

a. The gun is elevated or depressed manually by turning the handwheel on the left side, and is directed from the plotting room to the setter by telephone. After firing, the gun is returned to 177.8-mil (10-degree) elevation, the loading position.

22. TO LOAD.

a. **Spent Primer Ejection.** After a round has been fired, with the breech completely closed, raise the slide catch by pressing upward on the handle of the catch (fig. 15). This movement of the slide will eject the fired primer.

b. **Breech Opening.** Grasp the breech operating lever and pull it out of latch. Pull lever to rotate breechblock (fig. 12) and continue the motion to swing the block clear of the gun (figs. 13 and 14). Hold the breech open to the full extent to prevent interference with the operation of loading.

Gun and Carriage

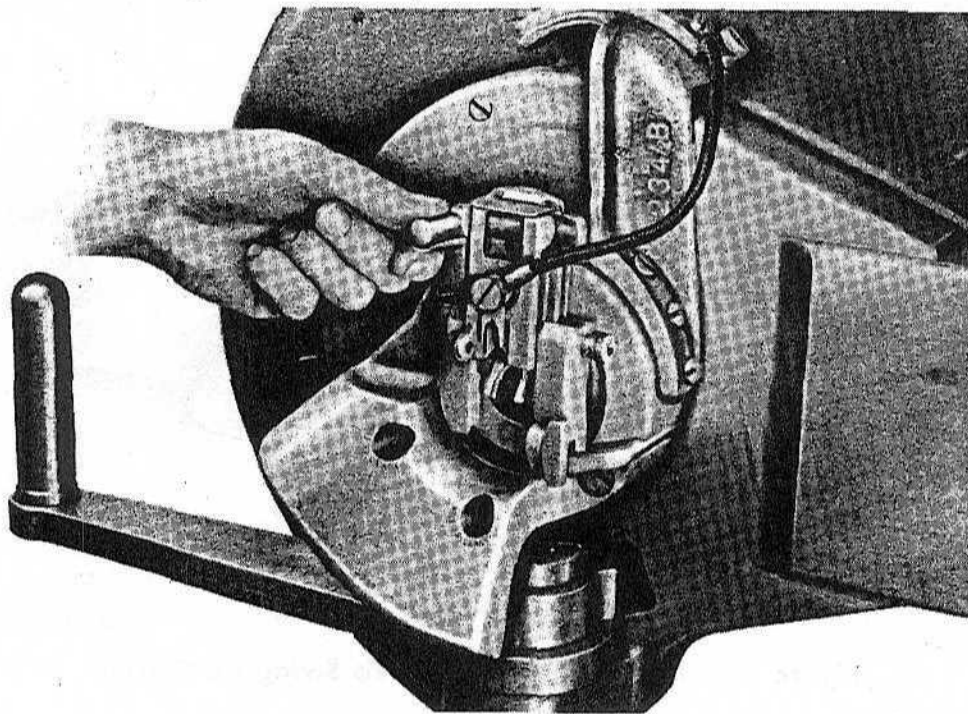

RA PD 39864

Figure 15 — Opening Firing Mechanism Slide To Remove Primer

c. **Projectile Ramming.** The projectile is brought up to the gun and placed in the chamber clear of breech sectors (hand loading) or on the loading tray, with the rammer head at the base of the projectile. The rammer is then driven smartly forward to seat projectile securely in the forcing cone.

d. **Powder Charge Insertion.** As the projectile is being rammed home, the prepared powder charge is brought up, placed with the igniter pad (dyed red) to the rear, and pushed home into the chamber.

e. **Breech Closing.** Close breech by means of operating lever, reversing the operation described in subparagraph b, above. Make certain the lever is latched in position.

f. **Primer Insertion.** After ejection of primer, clean vent and seat with primer seat cleaning brush, insert new primer, and drop slide down far enough to permit slide catch to engage the notch in the housing. The breech is then opened and the obturator spindle mushroom head is swabbed with wiping cloth dampened with clean water.

Gun and Carriage

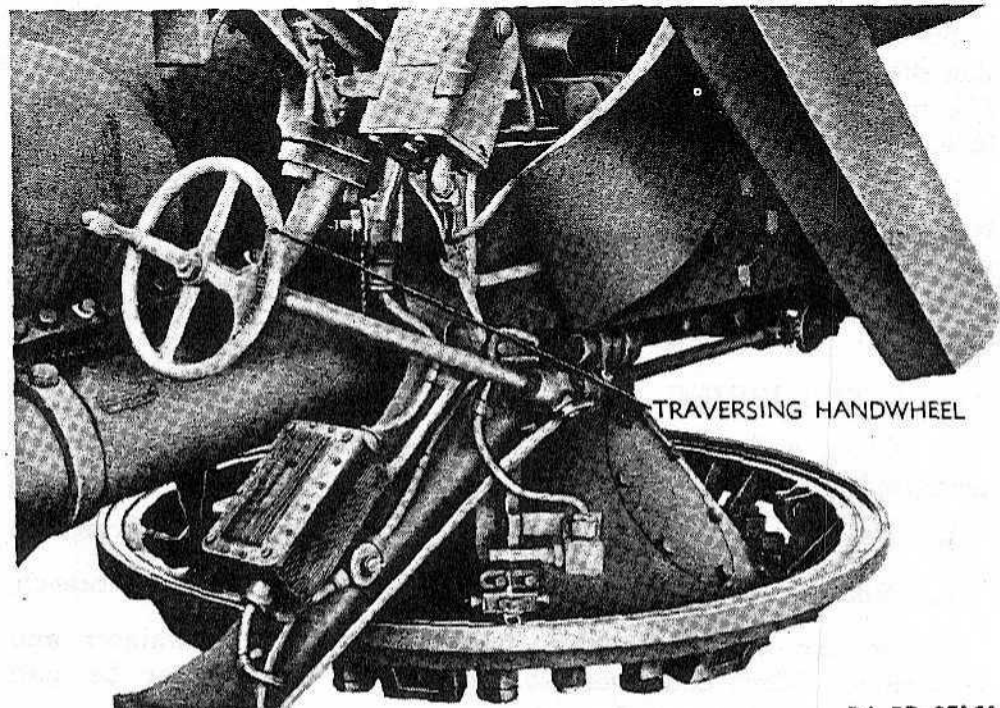

RA PD 95164

Figure 16 - Traversing Mechanism

23. TO FIRE.

a. **Electrical Firing.** The gun will be fired electrically by operating the magneto lever, except in the case of power failure or a broken firing circuit.

b. **Manual Firing.** To fire manually, using friction primer, a lanyard is attached to the lanyard loop on the firing lever, and the lanyard pulled with a quick strong pull (not a jerk).

c. **Misfire.** In the event of a misfire, follow the procedure prescribed in paragraph 29 a, observing the following precautions.

- (1) Keep the gun pointed at the target or in a clear field of fire.
- (2) All personnel must keep clear of the line of fire and the path recoil at all times during misfire procedures.
- (3) Use the butterfly net (improvised) when removing the primer from the firing mechanism.

24. TO UNLOAD.

a. **Service Rounds.** No unloading device is provided with this materiel for use in unloading service rounds of ammunition. When it is desired to unload the piece, the projectile may be fired out of the gun after it has been determined that the field of fire is clear. A projectile can be removed by applying an improvised unloading head

Gun and Carriage

to the ogive of the projectile. The head, however, must have an outside diameter of $5\frac{1}{2}$ to $5\frac{3}{4}$ inches and a central opening at least $3\frac{3}{4}$ inches in diameter and 6 inches long to clear the point-detonating fuze.

b. **Dummy Ammunition.** The dummy projectile may be extracted by inserting the hand extractor through the hole in the base of the projectile and pulling it back quickly to release the band from the chamber forcing cone. Push projectile forward and repeat if necessary. Withdraw projectile from gun.

25. AFTER FIRING.

a. Clean and oil, bore and breech mechanism as described in paragraph 35.

b. Clean and lubricate all tools and accessories used in firing.

c. Replace covers for direct fire sights, gun muzzle, and breech.

d. Return unused powder charges to original containers and wrappings. Mark containers so that opened charges may be used first at the next firing of the gun.

e. If the gun is active, projectiles may remain fuzed. If inactive, fuzes should be removed and returned to original boxes, and lifting eye plugs should be replaced in projectiles.

Section IV

LUBRICATION

26. LUBRICATION ORDER.

a. Reproduction of War Department Lubrication Order LO 9-424 (fig. 17) prescribes first and second echelon lubrication maintenance.

b. The points of application located on the Lubrication Order are illustrated in figures 18 and 19. They may be identified by the numbers around the border of the War Department Lubrication Order.

c. A War Department Lubrication Order is placed on or is issued with each item of materiel and is to remain with it at all times. In the event the materiel is received without a War Department Lubrication Order, a replacement will be requisitioned immediately in conformance with instructions and lists in FM 21-6.

27. GENERAL LUBRICATION SERVICING INSTRUCTIONS.

a. Lubricants are prescribed in the "KEY" in accordance with three temperatures ranges, "above $+32^{\circ}$ F," "from $+32^{\circ}$ F to 0° F," and "be

Gun and Carriage

low 0° F." The time to change to lubricants prescribed for a different temperature range is determined by maintaining a close check on operation of the materiel during the approach to prolonged periods when temperatures will be consistently higher or lower. Because of the time element involved in preparing for operation at lower prevailing temperatures, a change to lubricants prescribed for a lower range will be undertaken the moment operation becomes sluggish. Ordinarily, it will be necessary to change lubricants *only when expected atmospheric temperatures are consistently in a higher or lower range.*

b. Intervals specified on the Lubrication Order are minimum maintenance to be performed by the using organization. Intervals may be reduced under such conditions as excessively high ambient temperatures, extreme humidity, and dusty atmospheres during periods of prolonged firing or operation. Any one of these conditions may quickly destroy the protective qualities of the lubricants and require *more frequent servicing in order to prevent malfunctioning or damage to the materiel.* Lubricate materiel immediately following exposure to extreme moisture.

c. Lubrication Equipment.

(1) Clean lubricating equipment both before and after use. Operate lubricating guns carefully and in such manner as to insure a proper distribution of the lubricant. If lubricating fitting valves stick and prevent the entrance of the lubricant, remove the fitting and determine the cause. Replace broken or damaged lubricators. *If a lubricator cannot be replaced immediately, cover hole with tape as a temporary expedient to prevent the entrance of dirt.* If oil lines become clogged, disassemble the line and remove the obstruction.

(2) Lubricating fittings, grease cups, oil cups, oilholes, and fill, level, and drain plugs, unless otherwise specifically authorized, are circled in red for ready identification.

(3) Wipe lubricators and surrounding surface clean before applying lubricant. Where relief valves are provided, apply new lubricant until the old lubricant is forced from the vent. Exceptions are specified in notes or on the Lubrication Order. Metal surfaces on which a film of lubricant must be maintained by manual application will always be wiped clean before the film is renewed.

d. Cleaning.

(1) Unless otherwise specified, use rifle-bore cleaner or dry-cleaning solvent to clean or wash all metal parts of the gun and carriage whenever partial or total disassembly is undertaken or when renewing the protective lubricant film on exposed metal surfaces. Use of gasoline for this purpose is prohibited. Dry all parts thoroughly before lubricating. Flushing of gear cases or bearing housings, unless the inclosed mechanism is first disassembled, is not authorized.

Gun and Carriage

L0 9-424

WAR DEPARTMENT LUBRICATION ORDER

15 MARCH 1945 (Supersedes WDLO 72, 2 February 1944)

**GUN, 6-IN., M1900
CARRIAGE, BARBETTE, 6-IN., M1900**

References: TM 9-424, ORD 7 SNL E-4, ORD 7 SNL E-16

Clean fittings and oilers before applying lubricant. Lubricate following heavy rains. Intervals are based on actual operation under normal conditions. Reduce intervals under extreme dust, sand, heat or humid conditions. Extend when not in use.

Clean parts with CLEANER, rifle bore, or SOLVENT, dry cleaning. Dry before lubricating. (For exceptions, see GUN BORE, BRECH MECHANISM and FIRING MECHANISM Notes.) Lubricate dotted arrow points on both sides. Opposite points are shown by short arrows.

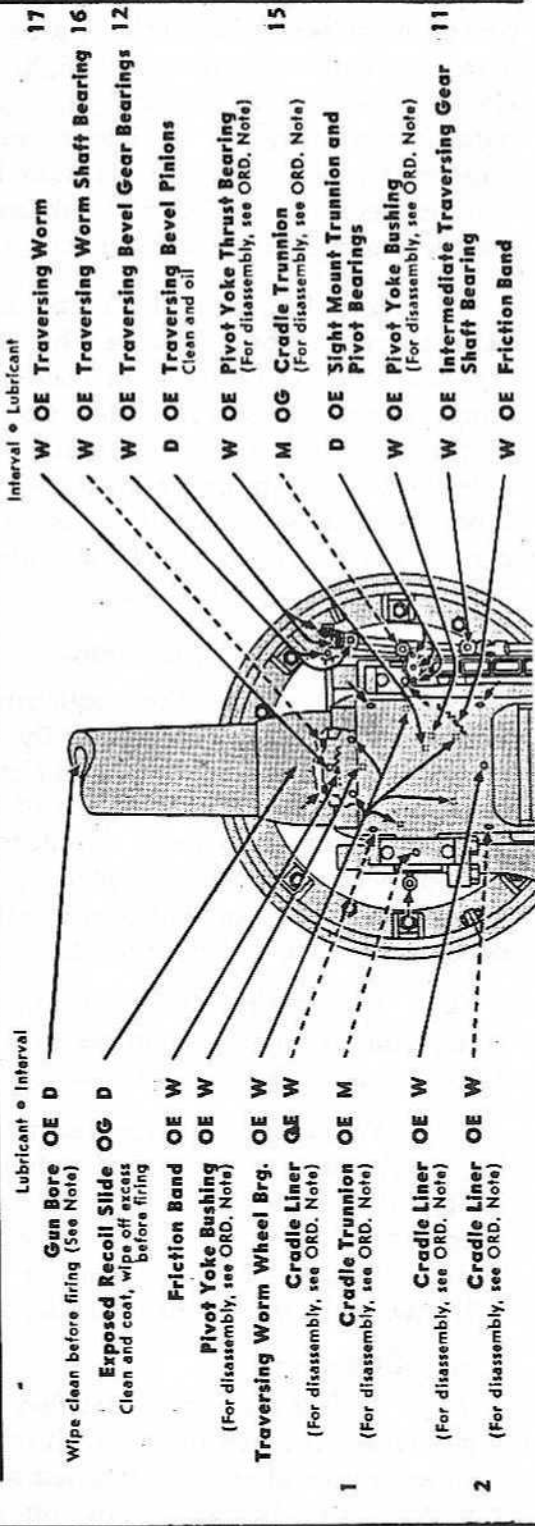
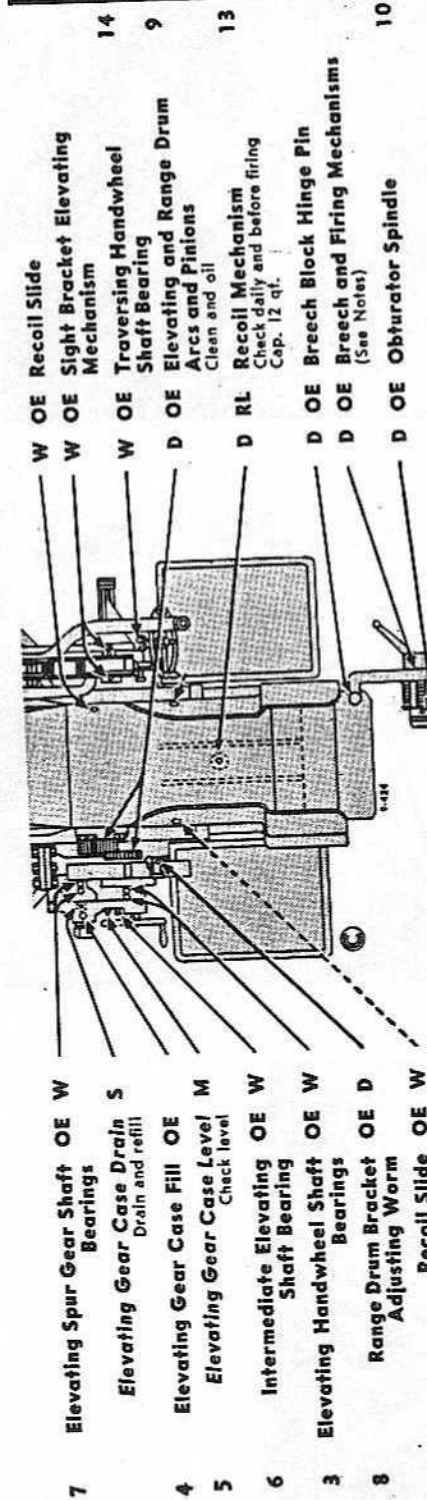

Figure 17 -



- 7 Elevating Spur Gear Shaft Bearings OE W
- 4 Elevating Gear Case Drain S
Drain and refill
- 5 Elevating Gear Case Fill OE
Check level
- 6 Intermediate Elevating Shaft Bearing OE W
- 3 Elevating Handwheel Shaft Bearings OE W
- 8 Range Drum Bracket Adjusting Worm OE D
- 10 Recoil Slide OE W
- 14 W OE Recoil Slide
- 14 W OE Sight Bracket Elevating Mechanism
- 9 W OE Traversing Handwheel Shaft Bearing
- 13 D OE Elevating and Range Drum Arcs and Pintons Clean and oil
- 13 D RL Recoil Mechanism Check daily and before firing Cap. 12 qt.
- 10 D OE Breech Block Hinge Pin
- 10 D OE Breech and Firing Mechanisms (See Notes)
- 10 D OE Obturator Spindle

KEY AND NOTES

LUBRICANTS	LOWEST ANTICIPATED AIR TEMPERATURES		LUBRICANTS	INTERVALS
	above +32°F.	+32°F. to 0°F.		
OE—OIL, engine	OE 30	OE 10	PS	D—Daily W—Weekly M—Monthly S—Semi-annually
OG—GREASE, O.D.	OG 0	OG 00	OG 00	

BREACH MECHANISM—After firing and on 3 consecutive days thereafter, disassemble the gas check pad from the obturator spindle and clean all parts of the breech mechanism, except the gas check pad, with CLEANER, rifle bore. Wipe dry and oil. Daily, during inactive periods, clean with CLEANER, rifle bore, wipe dry and oil. At time of disassembly, wipe the gas check pad clean (do not use dry cleaning solvent or bore cleaning solution). Apply a thin film of OE 30 above +32°F., or OE 10 below +32°F. prior to reassembly.

FIRING MECHANISM—Daily and immediately after firing, wipe clean and apply a film of oil. To remove corrosion or gummy deposits, disassemble, clean with CLEANER, rifle bore, wipe dry and oil prior to assembly.

GUN BORE—After firing, and on 3 consecutive days thereafter, clean with CLEANER, rifle bore. On 3rd day, if gun will not be fired within next 24 hours, wipe dry with oil. Daily, during inactive periods, renew the oil film—every 5 days, clean with CLEANER, rifle bore, wipe dry and reoil.

OIL CAN POINTS—Daily, lubricate Handwheel Handles, Traversing Universal Joints with OE.

DISASSEMBLE PERIODICALLY BY ORDNANCE PERSONNEL—Cradle Liners, Cradle Trunnion Bearings, Pivot Yoke Thrust Bearing and Bushing.
Copy of this Lubrication Order will be kept in the armament chest at all times; instructions contained therein are mandatory and supersede all conflicting lubrication instructions dated prior to 15 March 1945.

[A. G. 300.8 (15 March 1945)]

BY ORDER OF THE SECRETARY OF WAR:

OFFICIAL:
J. A. ULIO,
Major General,
The Adjutant General.

G. C. MARSHALL,
Chief of Staff.

Requisition additional Lubrication Orders in conformance with instructions and lists in FM 21-6.

RA PD 95156

Gun and Carriage

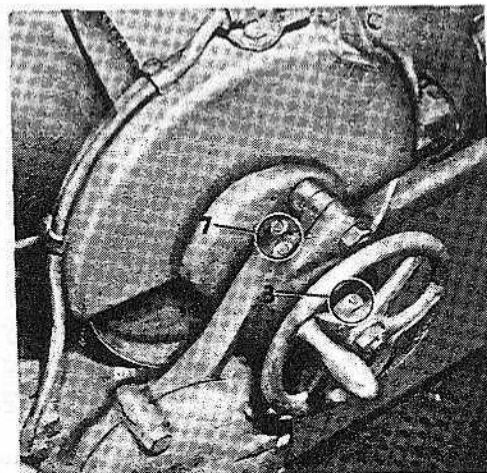
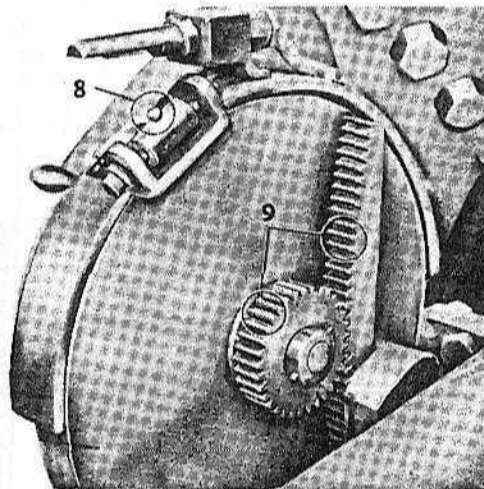
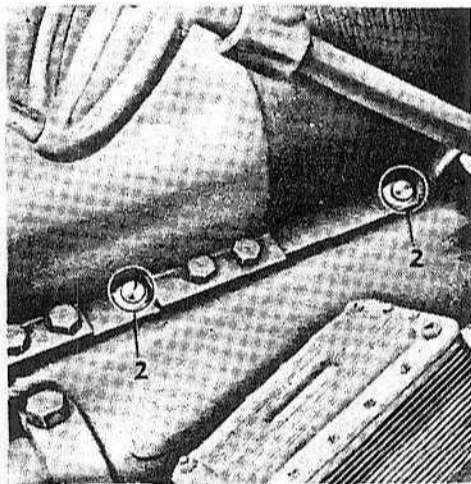
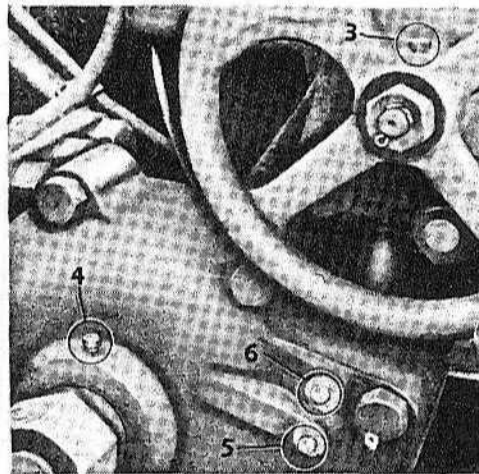
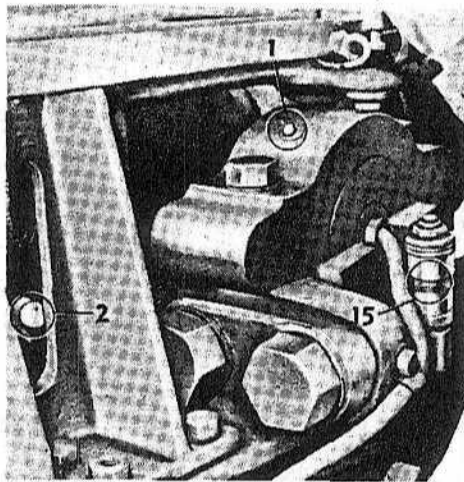

RA PD 95165

Figure 18 — Lubrication Points

Gun and Carriage

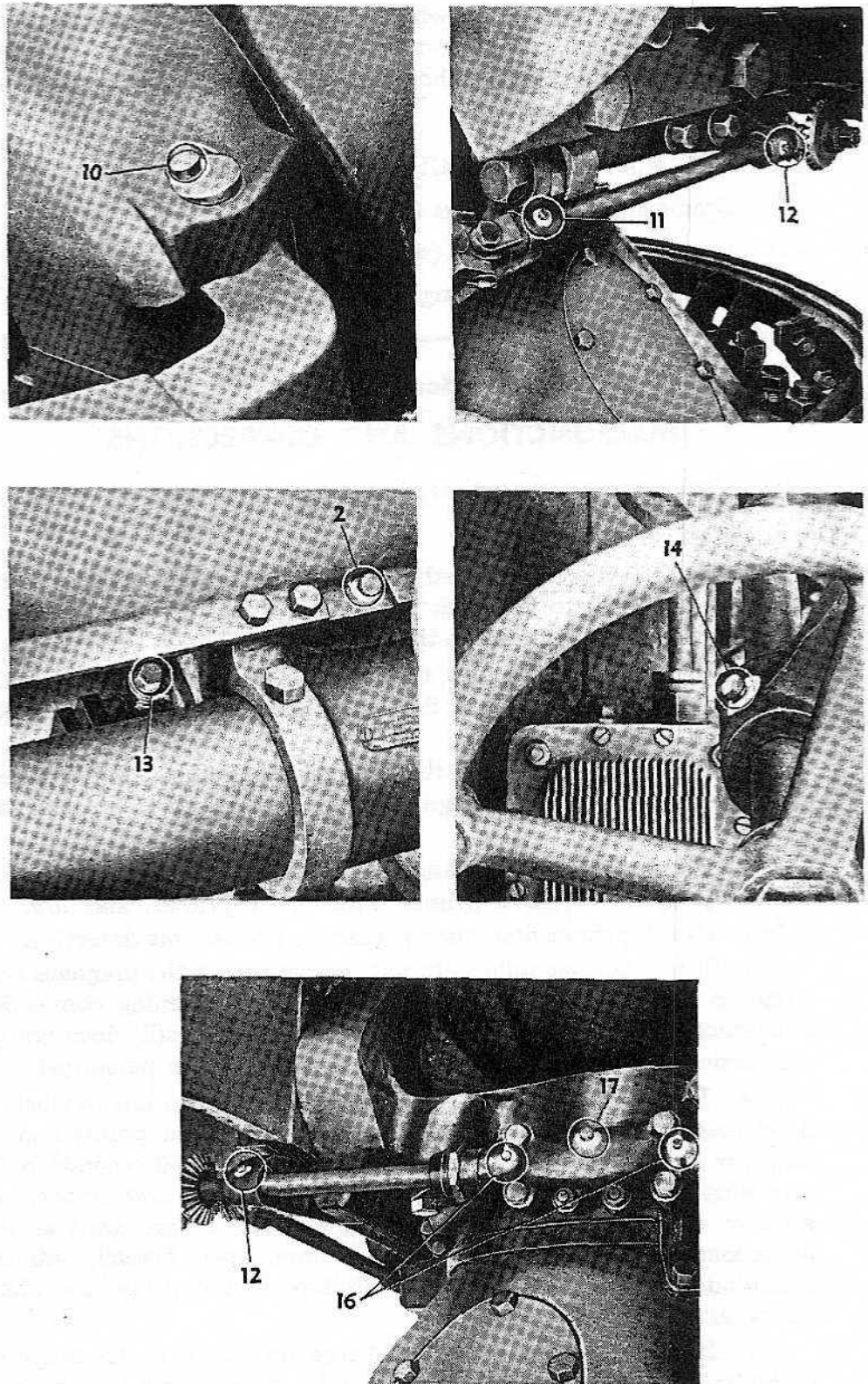

RA PD 95166

Figure 19 - Lubrication Points

Gun and Carriage

(2) Care must be taken when cleaning oil and grease compartments to insure the complete removal of all residue or sediment. Dirt or other foreign matter should not be allowed to drop into any of the lubricant reservoirs.

28. LUBRICATED BY HIGHER ECHELON.

- a. Cradle trunnion bearings (par. 38 a).
- b. Cradle liner (par. 37 a (4)).
- c. Pivot yoke thrust bearing and bushing (par. 38 d).

Section V**MALFUNCTIONS AND CORRECTIONS****29. GUN AND BREECH MECHANISM.****a. Misfire.**

(1) If it is uncertain whether primer has fired, eject the primer after two attempts to fire with the magneto, using the butterfly net to catch the primer. Examine the primer.

(a) If examination shows that the primer has not fired, either the primer was defective or the electric firing circuit was broken. Proceed as in step (2), below.

(b) If examination shows that the primer has fired, either a hang-fire has occurred or the charge has failed to ignite. Proceed as in step (3), below.

(2) **PRIMER IS NOT HEARD TO FIRE.** Make two attempts to fire the primer. Remove primer, insert new primer, and fire.

(a) If new primer fires, then preceding primer was defective.

(b) If new primer fails to fire, it indicates that the magneto firing circuit is defective. Check the firing circuit, tightening connections or contacts, and replacing broken wires. If primer still does not fire, use friction primer and notify ordnance maintenance personnel.

(3) **PRIMER IS HEARD TO FIRE.** As a precaution against the dangerous possibility of a hangfire, keep the piece pointed at the target or in a clear field of fire for a minimum of 60 seconds before removing primer. Clean out primer vent, insert new primer, and attempt to fire. If the primer is again heard to fire, wait at least 60 seconds, then remove expended primer, open breech, withdraw unexploded charge, and examine. Failure of the propelling charge indicates an abnormal condition.

(a) If the igniter end of the charge was against the projectile, if the igniter charge was folded over and not accessible to the primer flame, or if the igniter protector cap is still in place, make the correction and reinsert.

Gun and Carriage

(b) If the igniter is missing or wet, or if no obvious reason for failure is seen, replace the charge in the original container and wrapping. Mark container for future examination and report and remove to safe place pending examination.

b. Gas Leakages.

Cause	Correction
(1) Bruises on gas check pad or torn coverings.	(1) Replace.
(2) Burred or broken split rings.	(2) Replace.
(3) Dented or scored gas check pad seat.	(3) Report to ordnance maintenance personnel.

c. Breechblock Difficult To Open After Firing.

(1) Gas check pad stuck in seat.	(1) Remove, wipe clean, and apply a film of oil. Wipe off excess.
(2) Broken loading tray, interfering with breechblock.	(2) Remove tray and return it to ordnance maintenance personnel for repair. Load by hand.

d. Failure of Breech Mechanism To Operate Freely.

(1) Lack of lubrication. Burred, dented, or scored parts.	(1) Disassemble breech mechanism, clean, and relubricate (par. 36). Report damaged breechblock threads or other damaged parts to ordnance maintenance personnel.
---	--

e. Rifling of Gun Bore Rusted or Corroded.

(1) Bore improperly cleaned and oiled. Powder fouling or moisture corrosion.	(1) Clean and oil bore as outlined in paragraph 35 b.
--	---

30. RECOIL MECHANISM.**a. Gun Recoils With Shock.**

(1) Broken recuperator springs.	(1) Report to ordnance maintenance personnel.
(2) Void in recoil cylinder.	(2) Refill cylinder with oil (par. 37).

b. Gun Returns to Battery With Shock.

(1) Void in recoil cylinder.	(1) Refill cylinder with oil (par. 37).
------------------------------	---

Gun and Carriage

Cause	Correction
(2) Recoil cylinder piston rod improperly adjusted.	(2) Report to ordnance maintenance personnel.
(3) Piston rod striking cylinder head instead of gun resting on stop.	(3) Report to ordnance maintenance personnel.
c. Recoil and Counterrecoil Slow.	
(1) Recoil slides in cradle improperly lubricated.	(1) Relubricate.
(2) Recoil slide surface of gun barrel not properly lubricated.	(2) Clean and coat gun barrel with lubricant.
(3) Recoil oil cold and thickened.	(3) Recoil speed will be satisfactory after firing one or two rounds.
(4) Presence of rust on recoil slide.	(4) Remove rust and corrosion from recoil slide with crocus cloth.
(5) Sticky packings.	(5) Report to ordnance maintenance personnel.

31. ELEVATING MECHANISM.**a. Effort To Elevate Gun Uneven.**

(1) Elevating rack on cradle out of alinement.	(1) Report to ordnance maintenance personnel.
(2) Dirt between rack and elevating pinion gear.	(2) Clean rack and gear and relubricate.
(3) Ice or foreign material in gear housings.	(3) Report to ordnance maintenance personnel for removal and relubrication of elevating mechanism.
(4) Cradle trunnion bearings not properly lubricated.	(4) Lubricate bearings (sec. IV).
(5) Trunnion bearings rusted or damaged.	(5) Report to ordnance maintenance personnel.

b. Backlash in Handwheel.

(1) Wear of gears, worm, and wormwheel.	(1) Report to ordnance maintenance personnel.
(2) Elevating rack out of alinement.	(2) Report to ordnance maintenance personnel.
(3) Elevating rack and pinion improperly mated.	(3) Report to ordnance maintenance personnel.

Gun and Carriage

32. TRAVERSING MECHANISM.**a. Backlash in Handwheel.**

Cause	Correction
(1) Wear of worm and worm-wheel.	(1) Report to ordnance maintenance personnel.
(2) Wear of traversing rack and pinion gear.	(2) Report to ordnance maintenance personnel.

b. Handwheel Effort Excessively High.

(1) Dirt, rust, or gummed oil on pivot yoke and pedestal roller thrust bearing.	(1) Remove manhole plates in pedestal. Clean bearings and relubricate.
(2) Dirt on traversing worm-wheel.	(2) Clean and relubricate.
(3) Lubricating oil in worm and wormwheel case thickened by low temperature.	(3) Change lubricant (sec. IV).
(4) Worm sticking in case.	(4) Report to ordnance maintenance personnel.

Section VI

CARE AND PRESERVATION**33. GENERAL.**

a. It is of vital importance that all parts of the materiel be kept in proper condition so that the weapon is ready for immediate service. Lubricating, cleaning, and preserving materials provided with the gun and mount will enable the personnel to keep the parts in proper working condition. This section of this manual prescribes the uses of these materials.

b. Moving parts of the various mechanisms should be lubricated in the prescribed manner, and periodical examinations should be made to insure that the lubricant is reaching the parts for which it is intended.

c. Dirt and grit settle on bearing surfaces, and in combination with the lubricant itself, form a cutting compound. Powder fouling attracts moisture and hastens the formation of rust. It is essential that all parts be cleaned at frequent intervals, depending upon use and service. If rust should accumulate, its removal requires special care in order that clearances shall not be unduly increased. Crocus cloth should be used for this purpose. The use of coarse abrasives is forbidden.

Gun and Carriage

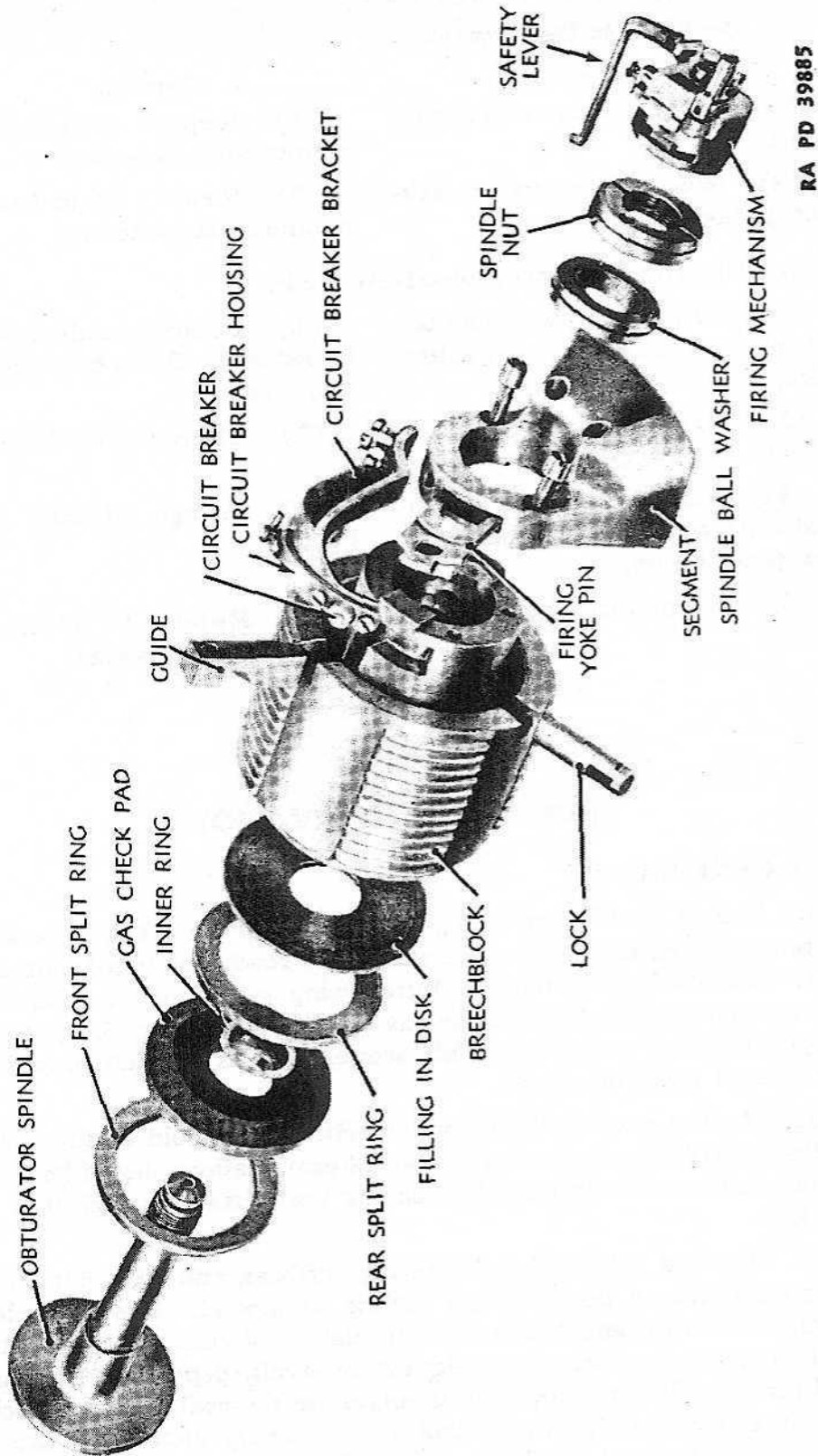

Figure 20 — Breechblock Mechanism — Exploded View

Gun and Carriage

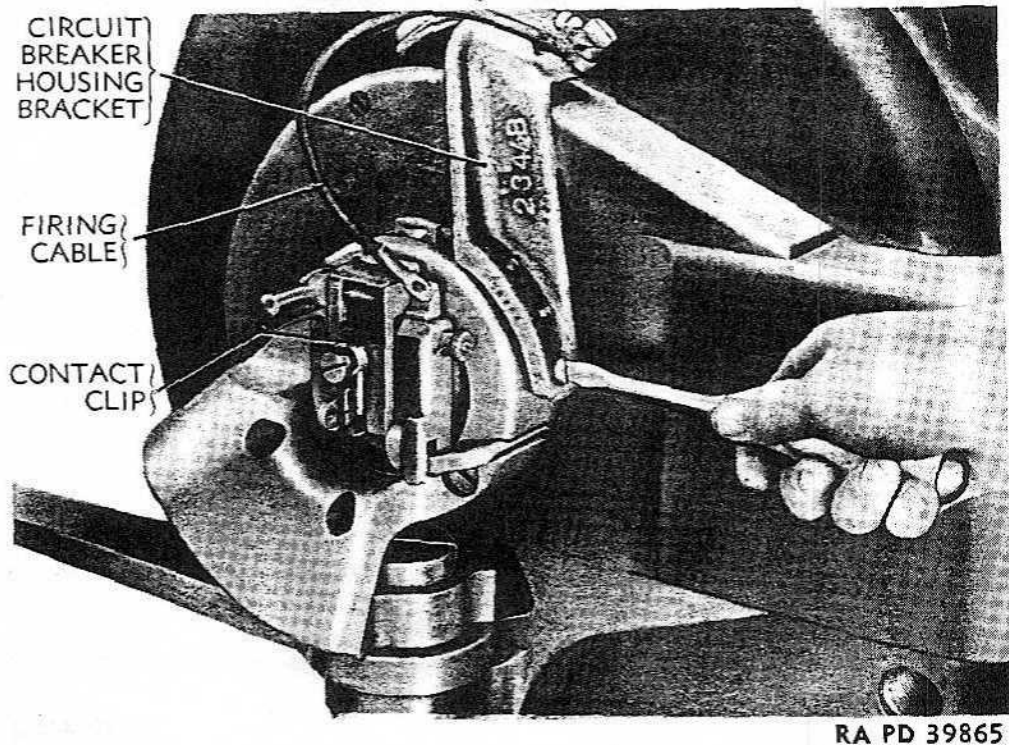

Figure 21 - Firing Contact Removal

d. In disassembly, assembly, or inspection, extreme care must be exercised to prevent dust, dirt, or other foreign matter from entering the mechanism of the gun.

e. When materiel is not in use, the proper covers must be used.

f. When the weapon is to be unused for a considerable length of time, the materiel should be prepared as described in paragraph 39.

g. Should an enemy shell burst near the weapon, it must be determined that the weapon has not been damaged to a dangerous degree before the next round is fired. Damage of a serious nature should be reported to ordnance maintenance personnel.

34. ORGANIZATIONAL EQUIPMENT AND ACCESSORIES.

a. All organizational equipment, tools, and accessories should be protected from loss or damage and kept in an orderly manner in the places provided for them so they can be quickly located when required. Items susceptible to rust and corrosion must be kept cleaned and coated with a film of preservative lubricating oil, medium or special, at regular intervals. Parts supplied in protective containers should be kept in the containers until required.

b. The sets of organizational equipment and accessories for the gun and mount should be maintained as complete as possible at all

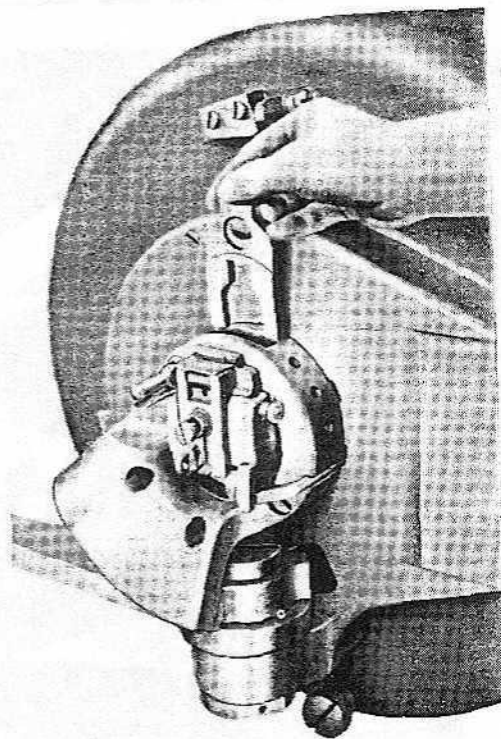

RA PD 39866

Figure 22 – Removing Firing Mechanism Yoke

times. The sets should be checked with the lists in the Standard Nomenclature Lists (ch. 9) and expended, missing, or seriously damaged parts should be replaced immediately.

35. GUN BARREL.

a. **General.** The wear on cannon depends not only upon the number of rounds fired, but also upon the care given the bore in cleaning, oiling, and cooling between rounds, as well as upon consistently following a thorough cleaning and oiling schedule. As the accuracy life of cannon is decreased by a fast rate of fire and the attendant heat, the piece should be washed, oiled, and allowed to cool as often as practicable. Copper fouling is less pronounced when the cannon is properly cared for. It is essential that each projectile be cleaned thoroughly before it is inserted in the gun. The bore should also be inspected as often as possible, to be sure it does not contain extraneous material which may damage the bore.

b. Cleaning Procedure.

- (1) Assemble staff sections and attach wire cleaning brush, wrapped with burlap.
- (2) Before firing, wipe clean.
- (3) After firing, when the gun has cooled to a point where it will not burn the hand, clean the bore with rifle-bore cleaner. Do not

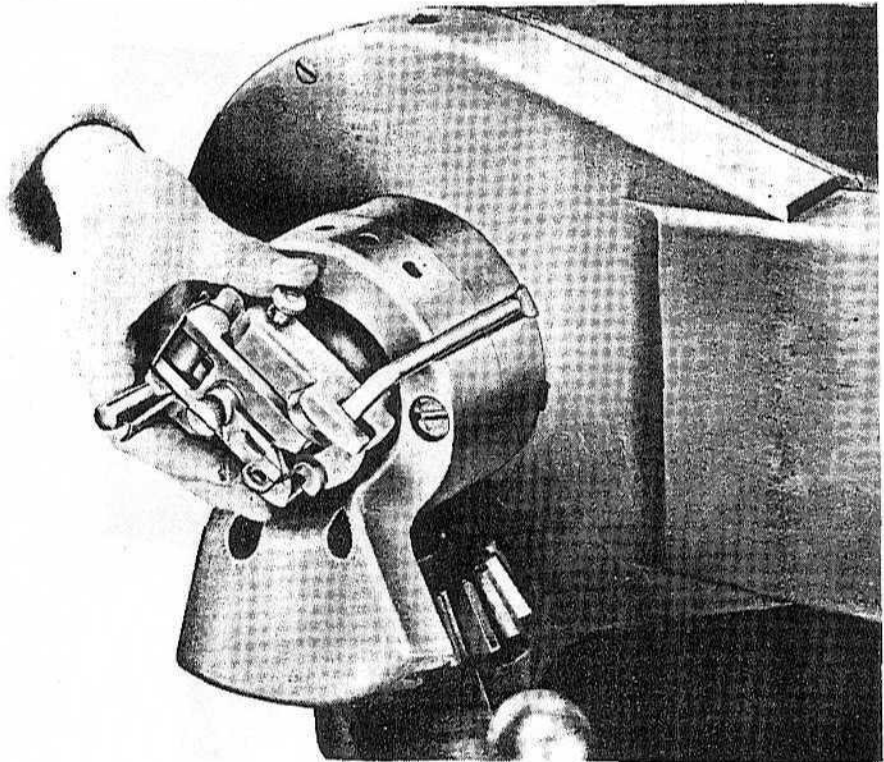
Gun and Carriage

RA PD 39867

Figure 23 – Removing Firing Mechanism

wipe dry. The gun will not be allowed to remain, after firing, without cleaning. Repeat this procedure on 3 consecutive days thereafter or until there is no longer evidence of sweating. After the fourth cleaning, if no firing is contemplated within 24 hours, wipe dry and oil.

(4) Daily, while alert or active but not firing, wipe the bore clean and renew the oil film. Every 5 days, clean with rifle-bore cleaner, and wipe dry and reoil.

c. **Recoil Slide.** The recoil slide surfaces of the gun barrel should be kept clean and well lubricated.

36. BREECH AND FIRING MECHANISM.**a. General.**

(1) Keep the breech mechanism well lubricated. When the gun is not in use, the breech cover should be in place to keep it clean and free of dust.

(2) Occasionally, during firing, residue works its way back through the vent hole in the spindle to the primer seat, causing the primer to seat improperly. After firing, this residue should be removed by reaming out the primer seat with the primer seat cleaning reamer. At this time the vent hole in the spindle should also be cleaned.

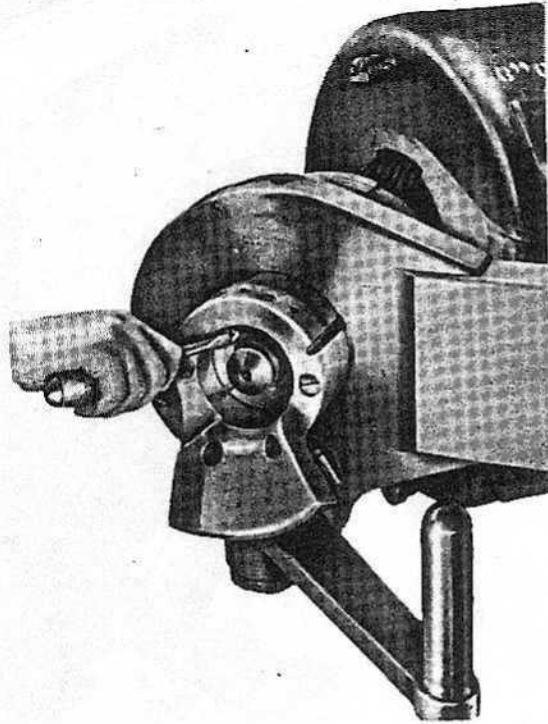
Gun and Carriage

RA PD 39868

Figure 24 —Removing Spindle Nut Screw

(3) If the breechblock does not operate smoothly, or if difficult to operate, the breech mechanism should be disassembled and all parts inspected to determine the cause.

(4) Any cutting or abrasive action in the threads of the breech recess and breechblock should be reported to ordnance maintenance personnel for correction.

b. Breech Mechanism.

(1) After firing and on 3 consecutive days thereafter, disassemble the gas check pad from the obturator spindle and clean all parts of the breech mechanism, except the gas check pad, with rifle-bore cleaner. Wipe dry and oil.

(2) Daily, while alert or active but not firing, clean with rifle-bore cleaner, wipe dry, and oil.

c. Gas Check Pad and Seat.

(1) Extreme care must be taken to prevent injury to the gas check seat. Dents or deep scoring of the metal should be reported to ordnance maintenance personnel.

(2) The gas check pad should be protected against injury. A dented or torn outer surface will cause gas leakage.

(3) When disassembling breechblock, wipe the gas check pad clean with clean, dry cloth (do not use dry-cleaning solvent or other

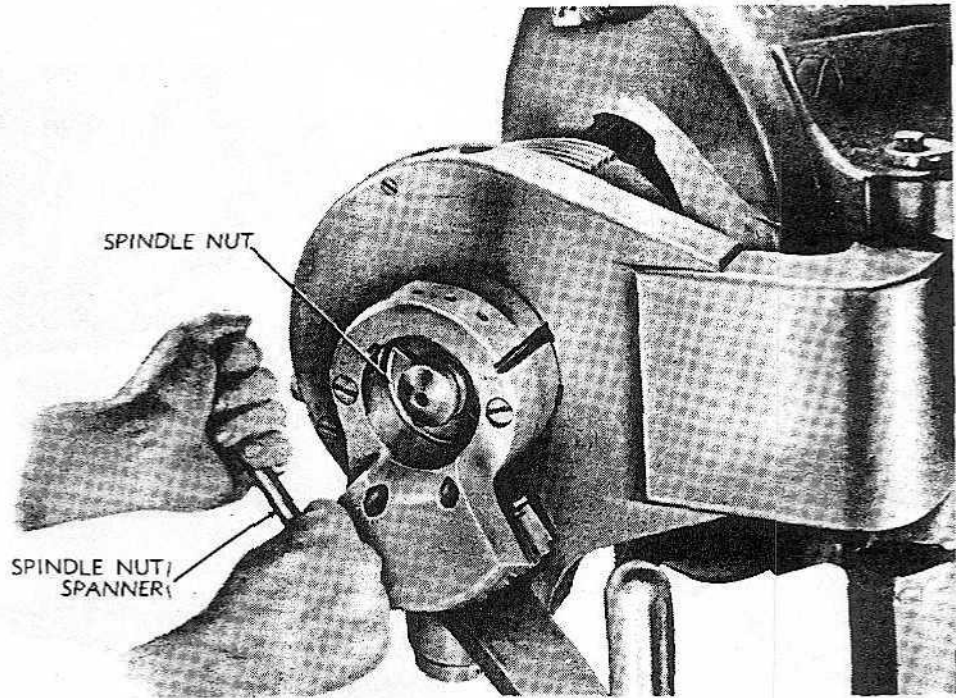

RA PD 39869

Figure 25 — Removing Obturator Spindle Nut

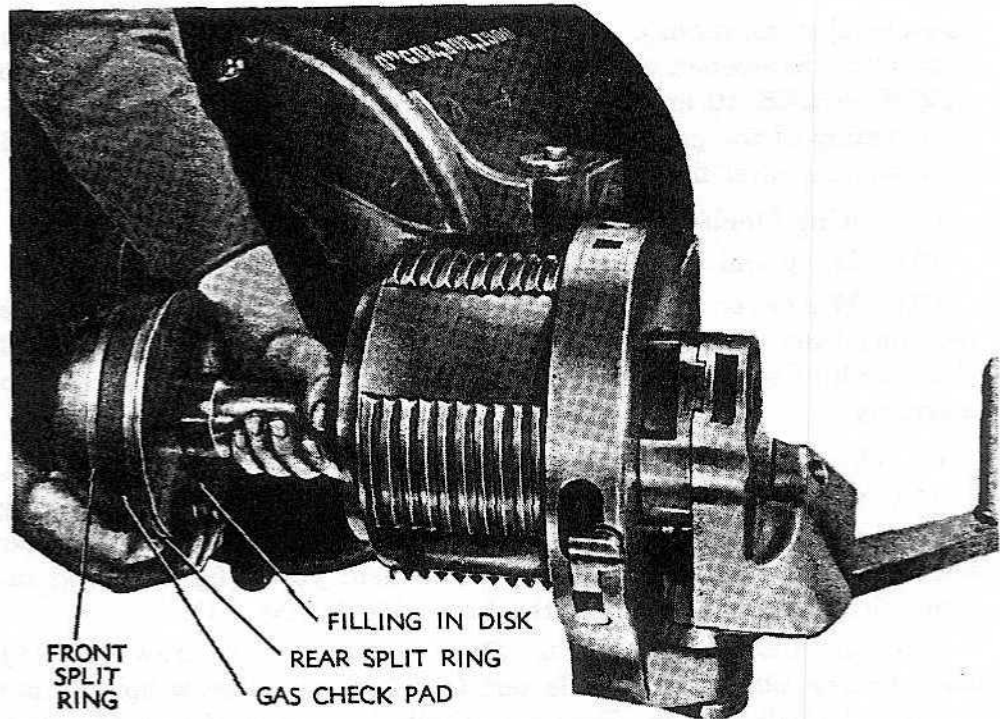

RA PD 39870

Figure 26 — Removing Spindle

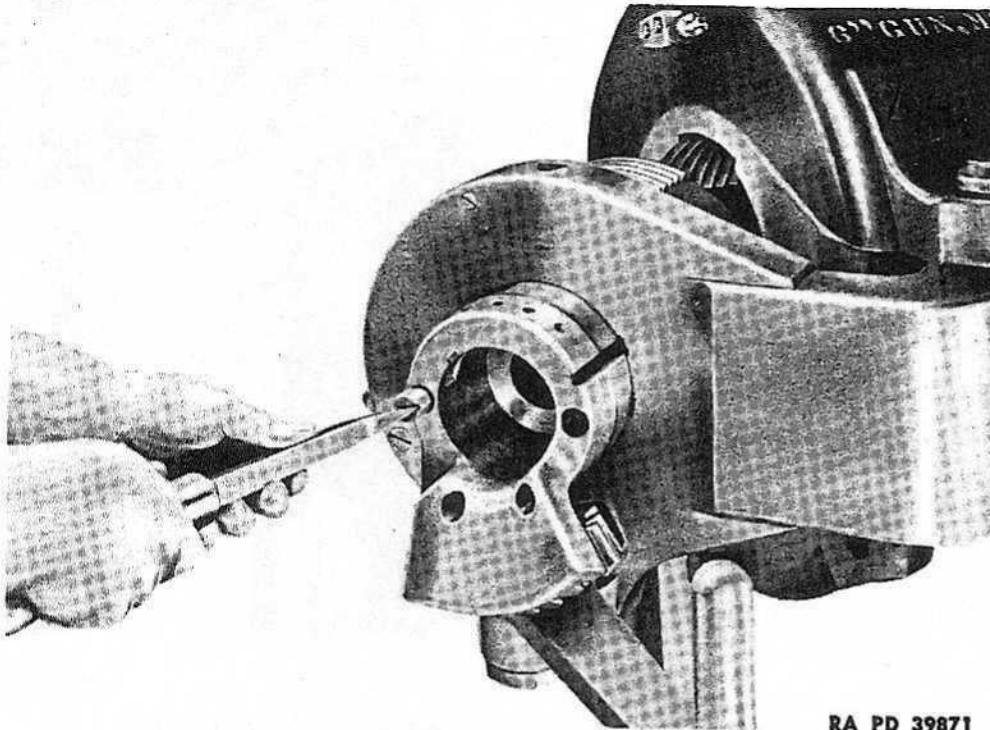

RA PD 39871

Figure 27 —Removing Segment Gear Screws

bore-cleaning solutions). Prior to reassembly, wipe lightly with a clean cloth, dampened with engine oil (SAE 30 at temperatures above $+32^{\circ}\text{F}$ or SAE 10 at temperatures below $+32^{\circ}\text{F}$). This will prevent rusting of the gas check seat and will aid in preventing the pad from sticking after firing the first few rounds.

d. Firing Mechanism.

- (1) Daily and after firing, wipe clean and oil.
- (2) Whenever there is evidence of corrosion or gummy deposits resulting from congealed oil, disassemble the firing mechanism and clean with rifle-bore cleaner. Wipe thoroughly, dry, and oil prior to assembly.

e. Disassembly of Breech Mechanism (fig. 20).

(1) **REMOVAL OF FIRING MECHANISM.** Disconnect the firing cable from the contact clip (fig. 21) and remove circuit breaker housing bracket. Lift out firing mechanism yoke (fig. 22) and remove firing mechanism from the breechblock (fig. 23).

(2) **OBTURATOR REMOVAL.** Remove spindle nut screw (fig. 24) and unscrew obturator spindle nut (fig. 25). Withdraw spindle nut and spindle ball washer. Remove spindle from breechblock (fig. 26), being careful not to bruise gas check pad, and to hold filling in disk, split rings, and pad in place until completely clear of breechblock.

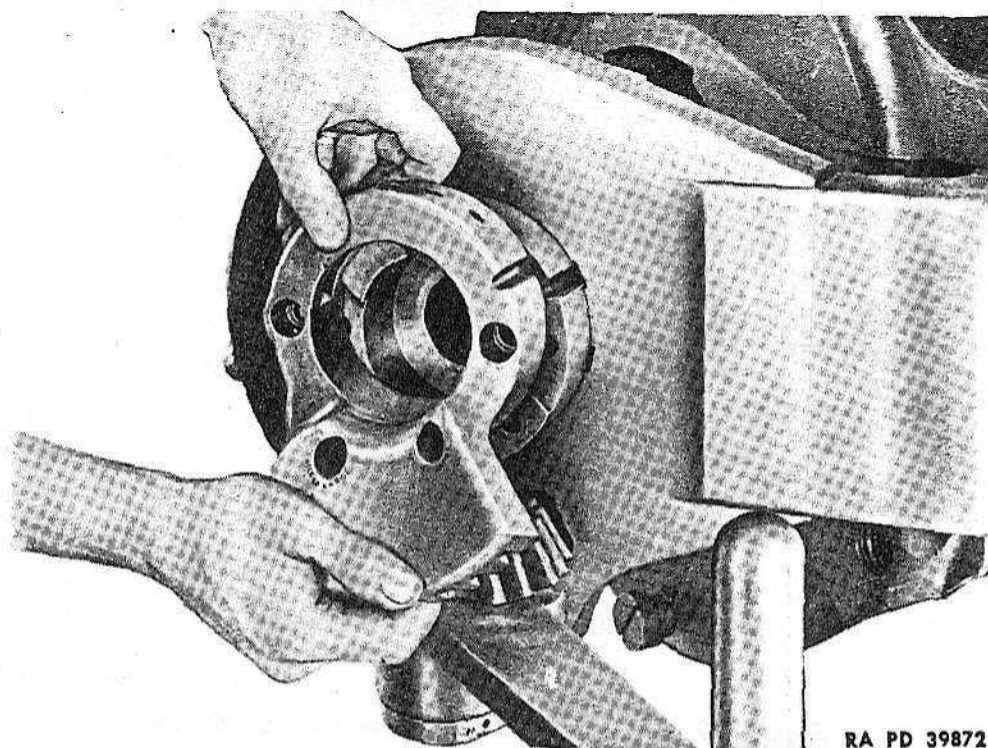

RA PD 39872

Figure 28 – Disassembling Gear Segment

(3) **GEAR SEGMENT REMOVAL.** Open breech, remove gear segment screws (fig. 27), and remove gear segment (fig. 28).

(4) **REMOVE BREECHBLOCK FROM CARRIER.** Unscrew breechblock guide screw (fig. 29); withdraw breechblock guide (fig. 30). Unscrew breechblock lock screw (fig. 33) and remove breechblock lock, spring, and lever (fig. 32); this releases breechblock from carrier. A similar result is effected manually, when complete disassembly is not required, by compressing the breechblock lock (fig. 33). Support breechblock by a sling (fig. 34), remove same from carrier, and lower to floor.

(5) **OPERATING LEVER DISASSEMBLY.** Punch out pinion nut pin (fig. 35) and unscrew nut, then withdraw pinion screw (fig. 36) and remove operating pinion and lever.

(6) **CARRIER REMOVAL.** Support weight of carrier and start hinge pin with drift and hammer (fig. 37). Sling carrier and complete release of hinge pin (fig. 38). Assemble parts of disassembled carrier (fig. 39).

(7) **DISASSEMBLE FIRING MECHANISM.** Drive out pin from slide stop nut and unscrew nut (fig. 40). Withdraw slide stop and the slide may be withdrawn from the housing, releasing the ejector and safety lever.

Gun and Carriage

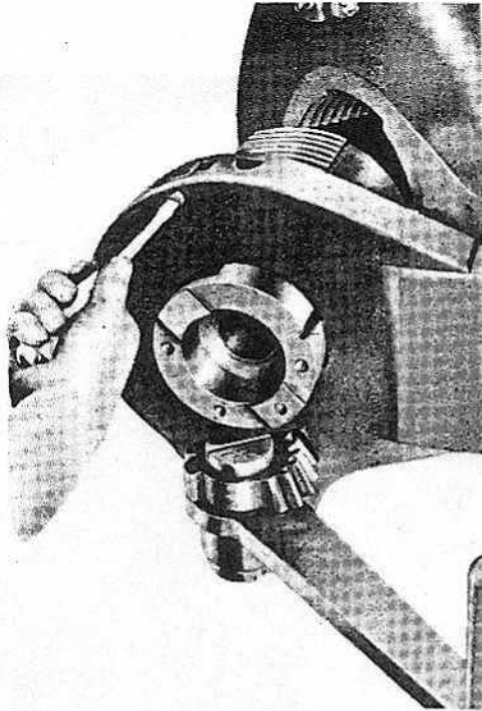

RA PD 39873

Figure 29 — Removing Breechblock Guide Screw

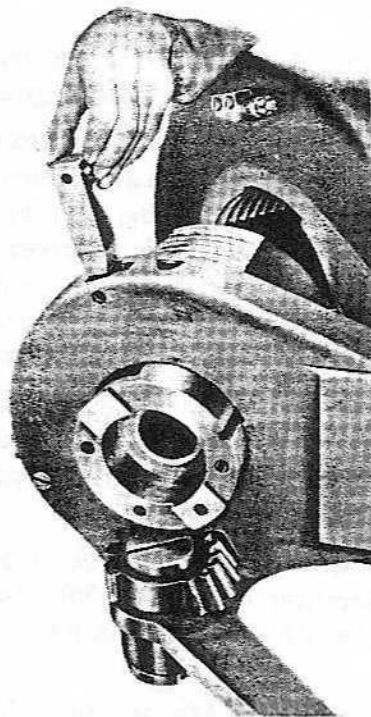

RA PD 39874

Figure 30 — Removing Breechblock Guide

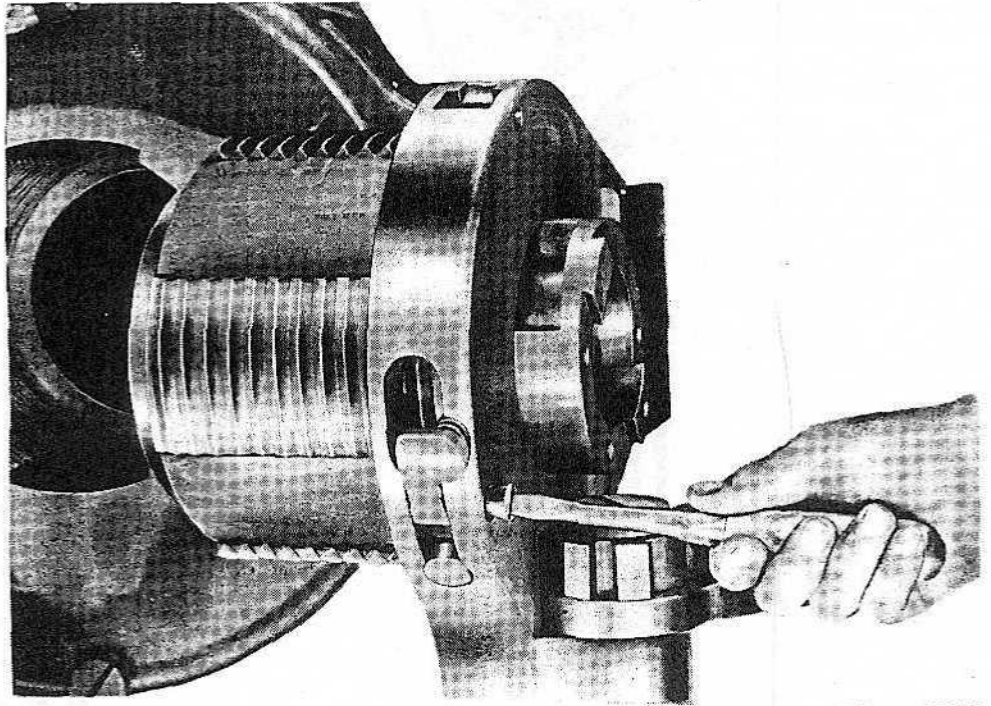

RA PD 39875

Figure 31 — Removing Breechblock Lock Screw

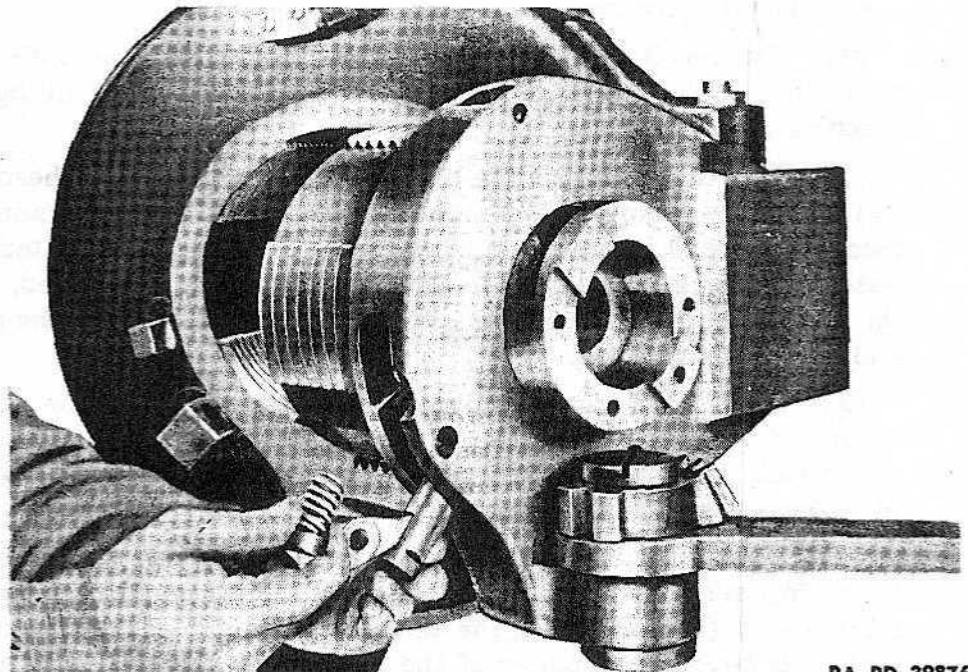

RA PD 39876

Figure 32 — Removing Breechblock Lock, Spring, and Lever

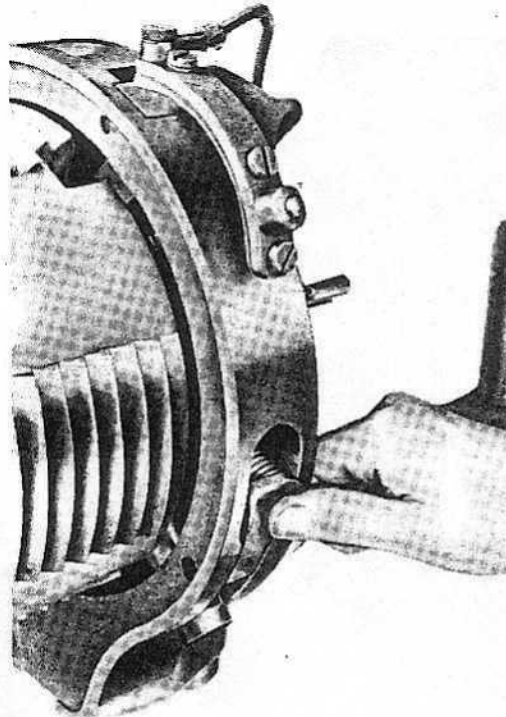
Gun and Carriage

RA PD 39855

Figure 33 – Releasing Breechblock Lock Manually To Move Out Breechblock

37. RECOIL MECHANISM.

a. Recoil Cylinder.

(1) The recoil cylinder must be kept filled at all times with recoil oil (light). The gun is to be at 0.0-mil elevation when filling and checking oil levels.

(2) The drain plug at the bottom of the rear cylinder head (fig. 41) should be removed at 6-month intervals and a small amount of recoil oil drained into a clean container. If oil is contaminated with water or rust, drain and refill. The cylinder may be flushed, using the plumber's force pump. Be sure to wash off all oil from the pump and hoses after flushing.

(3) If oil leaks from the piston rod packing, tighten the rod follower to further compress the gland and packing material around the piston rod. If oil spurts out when the gun is fired and the packing is tight, report to ordnance maintenance personnel.

(4) Every 6 months the gun should be pulled out of battery and the sliding surfaces of the gun cleaned with dry-cleaning solvent and relubricated (sec. IV). If the operation of pulling the gun out of battery is beyond the power of the battery personnel, report to ordnance maintenance personnel.

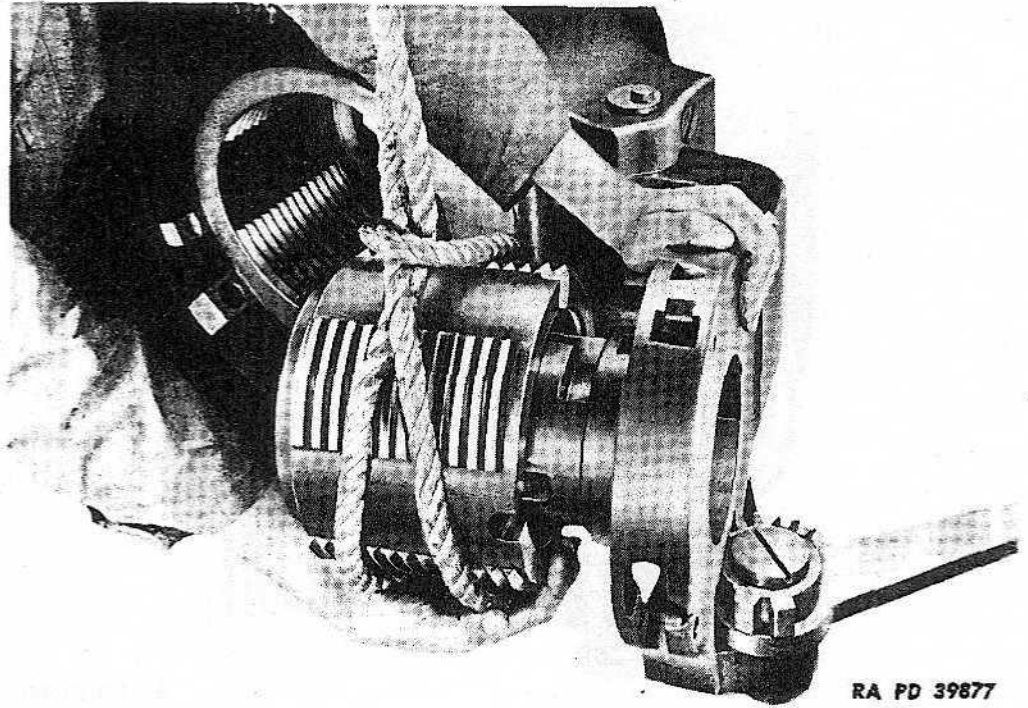

Figure 34 — Removing Breech

RA PD 39877

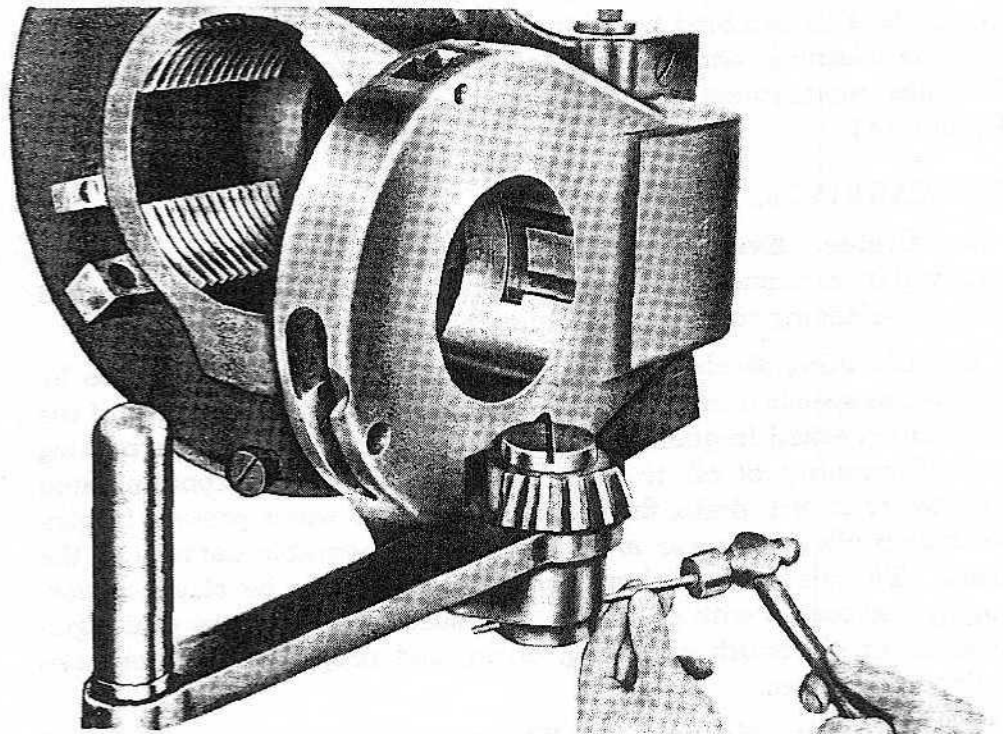
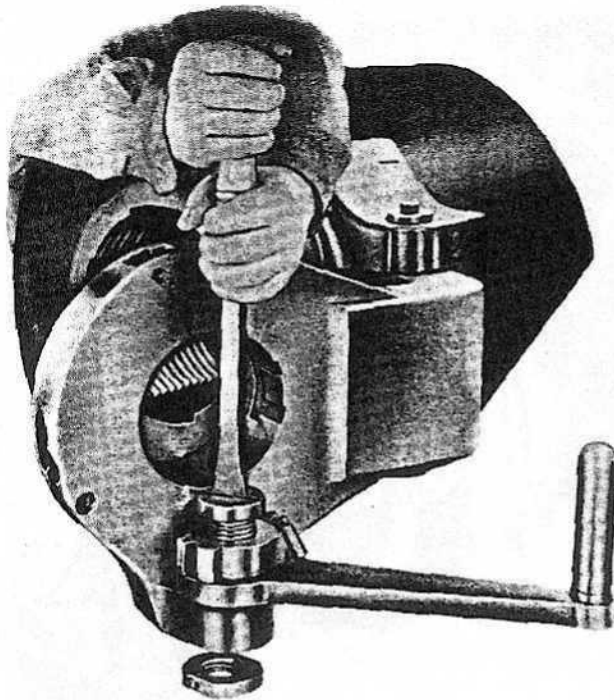

Figure 35 — Removing Operating Lever Pinion Nut Pin

RA PD 39879

Gun and Carriage

RA PD 39880

Figure 36 — Removing Operating Lever Pinion — Nut Removed

(5) Every two years the recoil cylinder and recuperator springs should be disassembled by ordnance maintenance personnel for inspection, cleaning, and lubricating of recuperator springs and cylinders, also replacement of recoil piston rod packing if necessary (figs. 42 and 43).

38. CARRIAGE.

a. **Cradle.** Every 6 months the trunnion bearing caps should be removed by ordnance maintenance personnel and the bearing cleaned with dry-cleaning solvent and relubricated (sec. IV).

b. **Elevating Mechanism.** The elevating mechanism is to be lubricated as specified in the Lubrication Order, and the condition of the lubricant checked frequently by removing drain plugs and permitting a small quantity of oil to drain out. If lubricant is contaminated with water or dirt, drain, flush, and refill as the water present in contaminated oils will freeze and may cause irreparable damage to the gears. The elevating pinion gear and rack are to be cleaned thoroughly and coated with oil daily. The successful elevation of the gun depends on a smooth operating, clean, and properly lubricated elevating mechanism.

c. **Traversing Mechanism.** The traversing mechanism worm and wormwheel are to be lubricated as specified in Lubrication Order.

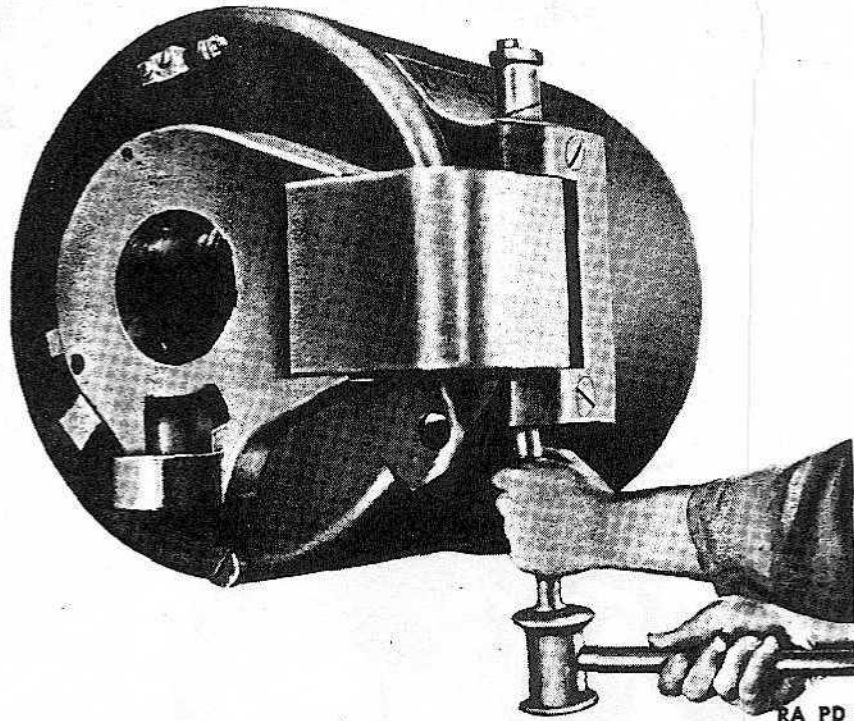

RA PD 39881

Figure 37— Driving Out Hinge Pin

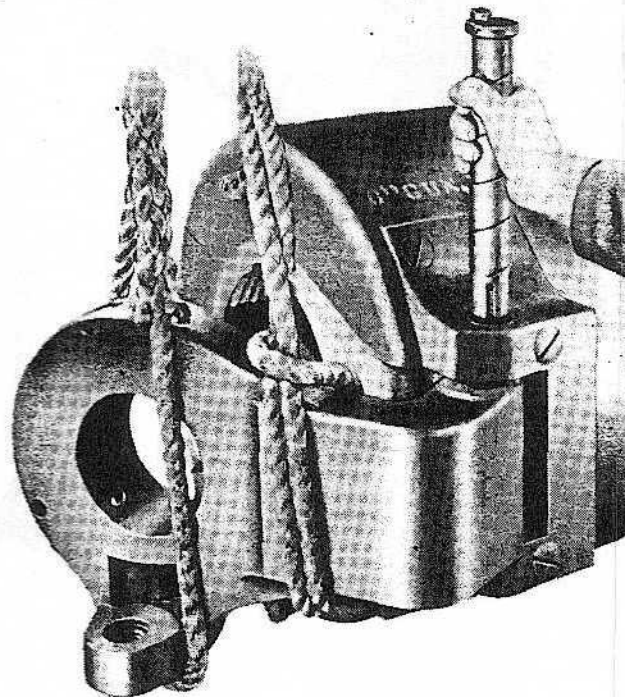

RA PD 39882

Figure 38 — Removing Carrier

Gun and Carriage

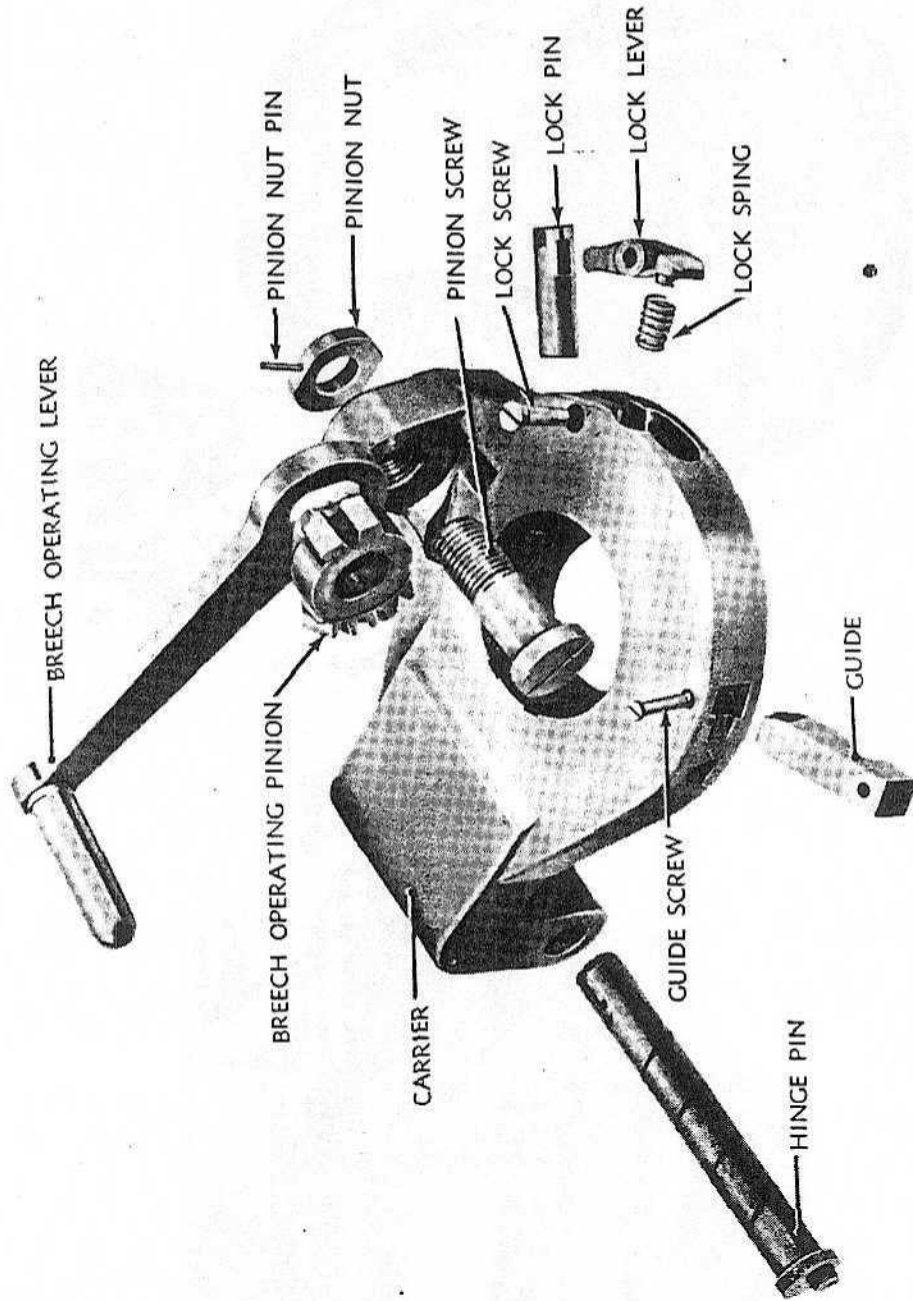

RA PD 39883

Figure 39 — Carrier — Exploded View

Gun and Carriage

Excessive handwheel backlash should be reported to ordnance maintenance personnel for correction.

d. **Base Thrust Bearing and Pivot Yoke.** At least once each year the manhole covers in pedestal should be removed, the gun raised, and base thrust bearing and pivot yoke bearing cleaned with dry-cleaning solvent and relubricated in accordance with the Lubrication Order. Any slackness or play should be reported to ordnance maintenance personnel.

39. PREPARATION FOR INACTIVE AND ACTIVE SEASON.

a. **General.** During the inactive season or when the gun is not to be used for a considerable time, materiel will be prepared and maintained as described below and in such manner as to permit its being prepared for service in not more than 72 hours.

b. Gun.

(1) **CLEAN GUN BORE.** If the gun has just been fired, clean and oil the bore and chamber on 3 consecutive days thereafter, as prescribed by the Lubrication Order, to remove all traces of powder fouling. Then swab the bore and chamber with dry-cleaning solvent and wipe thoroughly dry. Apply rust preventive (heavy), which has been heated to the proper fluidity to insure a thorough coverage of all surfaces.

(2) **METHOD OF SLUSHING BORE.** Use the bore greasing device (par. 74).

(3) **CLOSE ENDS OF GUN BORE.** After slushing, seal the bore with two layers of greaseproof wrapping paper and overwrap with a layer of waterproof barrier wrapping paper. Tape securely in place with nonhygroscopic adhesive tape and spray over tape with rust-preventive compound (thin film).

(4) **RECOIL SLIDES.** Clean and coat the recoil slide surfaces with rust-preventive compound (light).

c. Breech Mechanism.

(1) Remove the obturator spindle, split rings, gas check pad, and firing mechanism. Wipe the gas check pad, clean, and dry. Lubricate with engine oil (SAE 10), rubbing it in well. Then place in original container in armament chest. Clean other parts with dry-cleaning solvent, dry, and coat with rust-preventive compound (light); wrap in greaseproof wrapping paper and store in a protected place in a chest lined with waterproof barrier wrapping paper.

(2) Remove the breechblock and breechblock carrier. Clean and coat all parts with rust-preventive compound (light) and reassemble. Coat breechblock threads with rust-preventive compound (light) and close breech. Seal the breech in the same manner as used for sealing the bore, and install breech cover.

Gun and Carriage

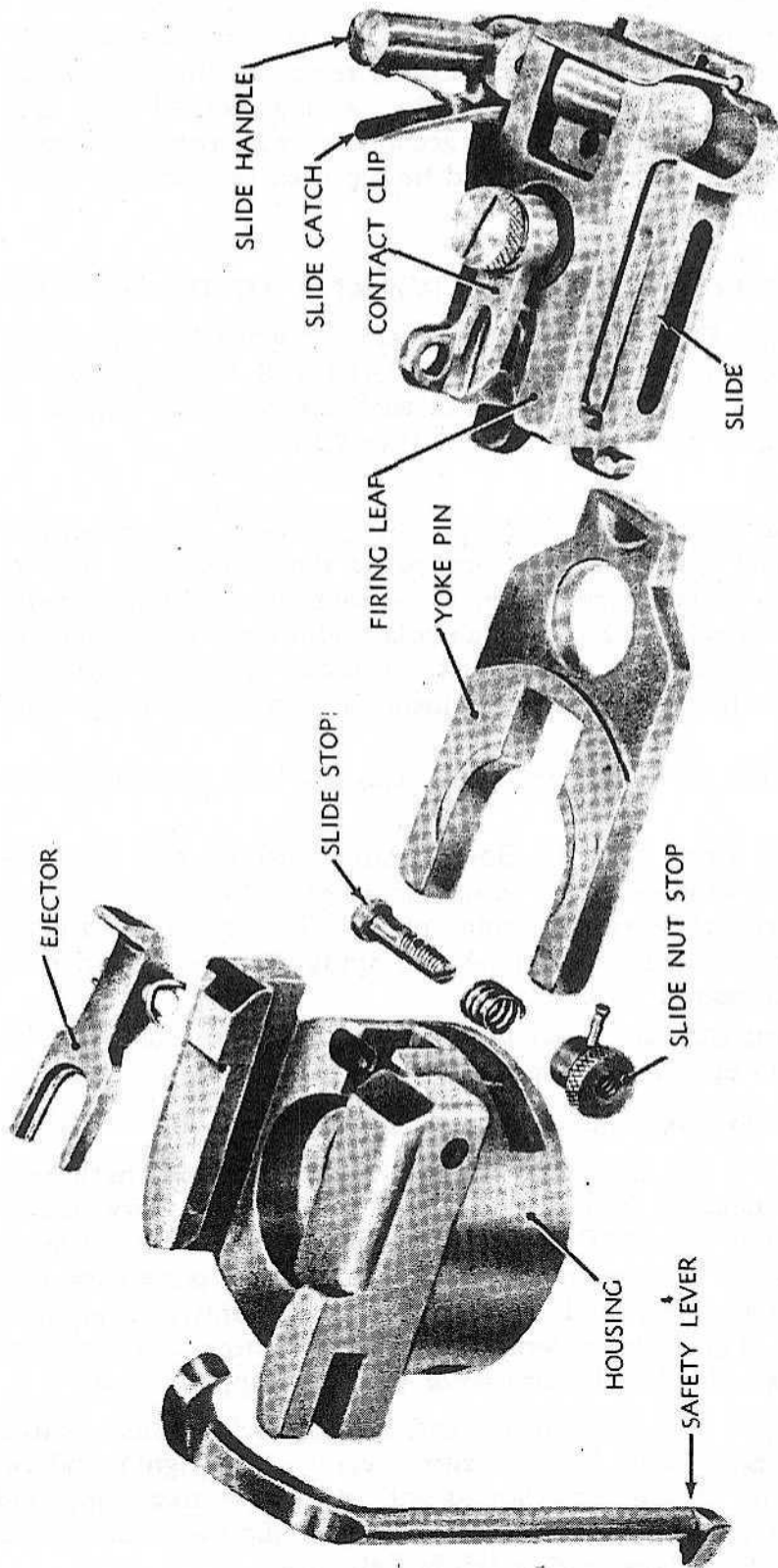

RA PD 39884

Figure 40 — Seacoast Firing Mechanism M1900 — Exploded View

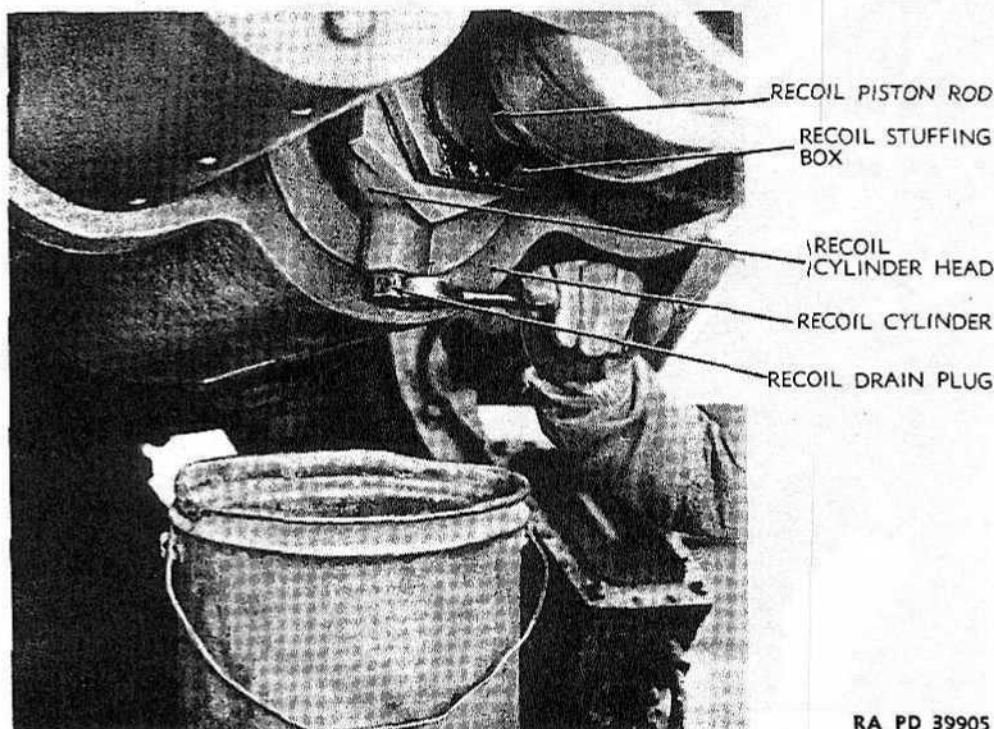
Gun and Carriage

RA PD 39905

Figure 41 – Emptying Recoil Cylinder M1900

(3) All parts removed from gun should be carefully marked with tags bearing name of battery, gun model, and serial number. Record of the temporary place of storage will be made and filed in battery emplacement book.

d. **Recoil Mechanism.** Be sure the recoil cylinder is filled with prescribed oil (fig. 44), that the cradle is lubricated, and all finished exposed surfaces coated with rust-preventive compound (thin film).

e. **Elevating and Traversing Mechanism.** Lubricate as prescribed in Lubrication Order. Drain gear cases and completely refill with preservative lubricating oil (medium).

f. **Pivot and Base Thrust Rollers.** Ordnance maintenance personnel should be called for release of rollers. Clean rollers, roller paths, and pivot bearings with dry-cleaning solvent; oil with preservative lubricating oil (medium); and coat with rust-preventive compound.

g. **Gun Emplacement.** Be sure that drains in gun emplacement are open and that no debris remains to clog the drains.

h. Properly covered and lubricated, the materiel will require little care while inactive; nevertheless, at regular intervals of 30 days or less, the amount of oil in the recoil cylinder should be checked and more of the prescribed oil added if necessary. The carriage should

Gun and Carriage

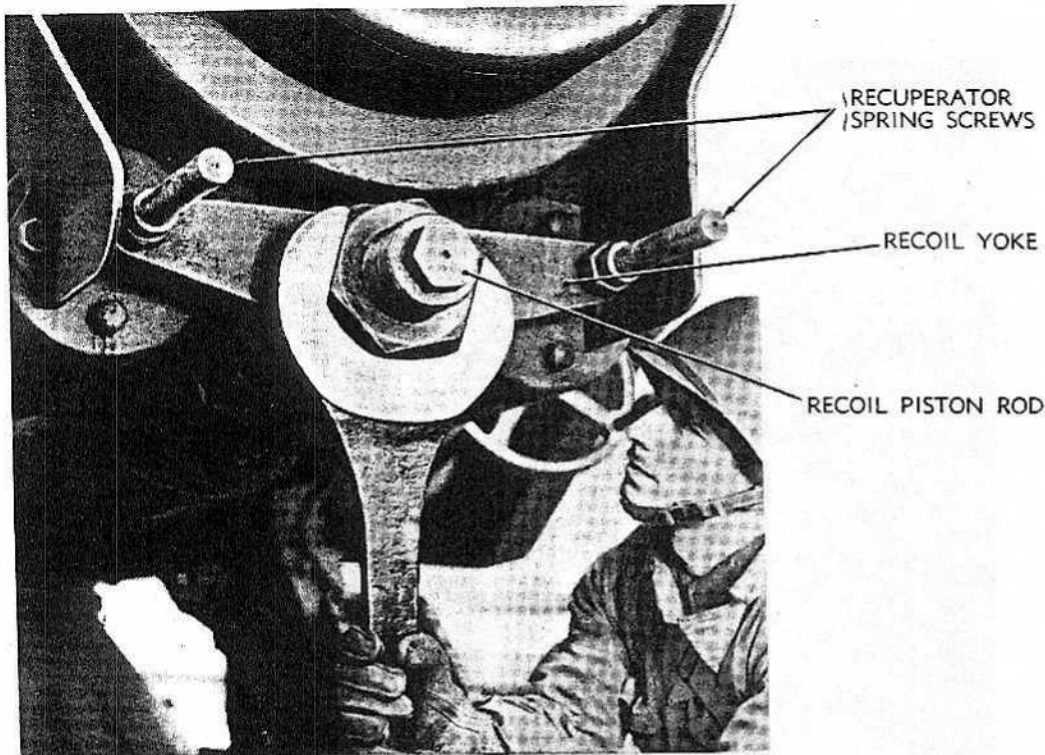

RA PD 39902

Figure 42 – Adjusting Recoil Piston Rod M1900

be traversed and elevated through its full range of travel in azimuth and elevation. *Leave carriage traversed about 30 degrees from its former position.*

i. It is especially required that all parts of the materiel be kept clean at all times. Rust should not be permitted to accumulate on metal surfaces. If rust is found upon inspection, remove with dry-cleaning solvent and crocus cloth, then recoat with prescribed preservative. Cracked or flaked painted surfaces should be retouched as soon as possible.

j. At the beginning of the active season, the materiel will be thoroughly cleaned and lubricated as prescribed by the Lubrication Order. Careful inspection of the finished and unfinished surfaces will be made for rust and marred paint. Cleaning and preparation of surfaces for repainting or touching up will be in accordance with the latest issued regulations and directives.

k. Remove covers and seals from gun bore and breech, and scrape out rust-preventive compound. Clean with dry-cleaning solvent and oil bore with the prescribed oil.

l. Remove breech and firing mechanism parts from storage place. Disassemble, clean, lubricate, and assemble.

Gun and Carriage

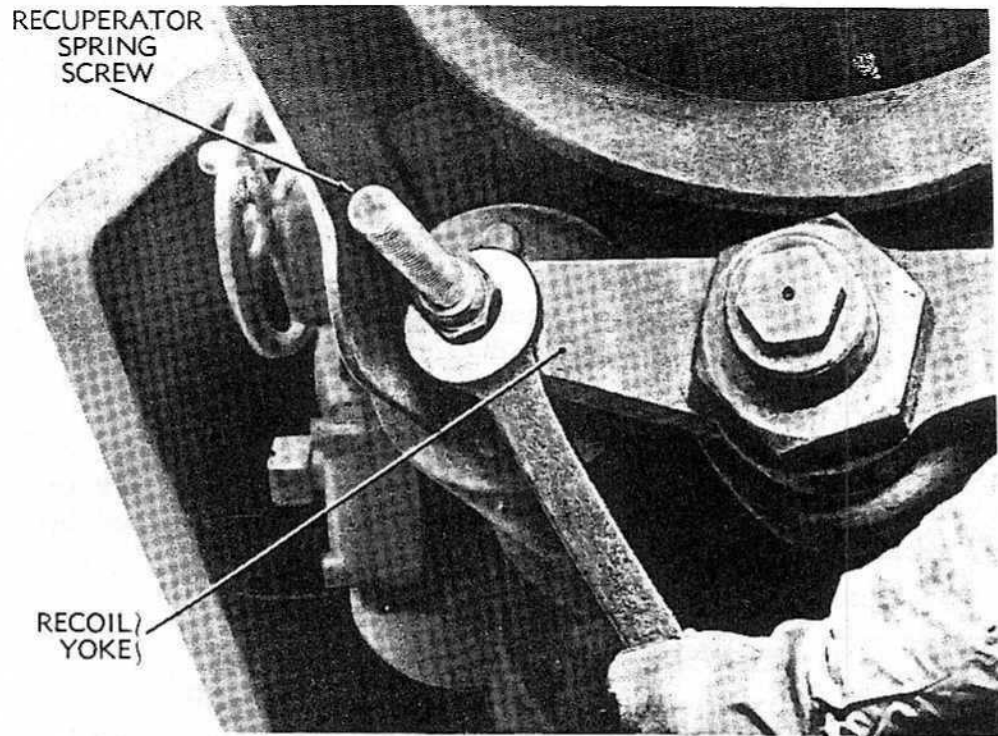

RA PD 39903

Figure 43 — Adjusting Recuperating Spring M1900

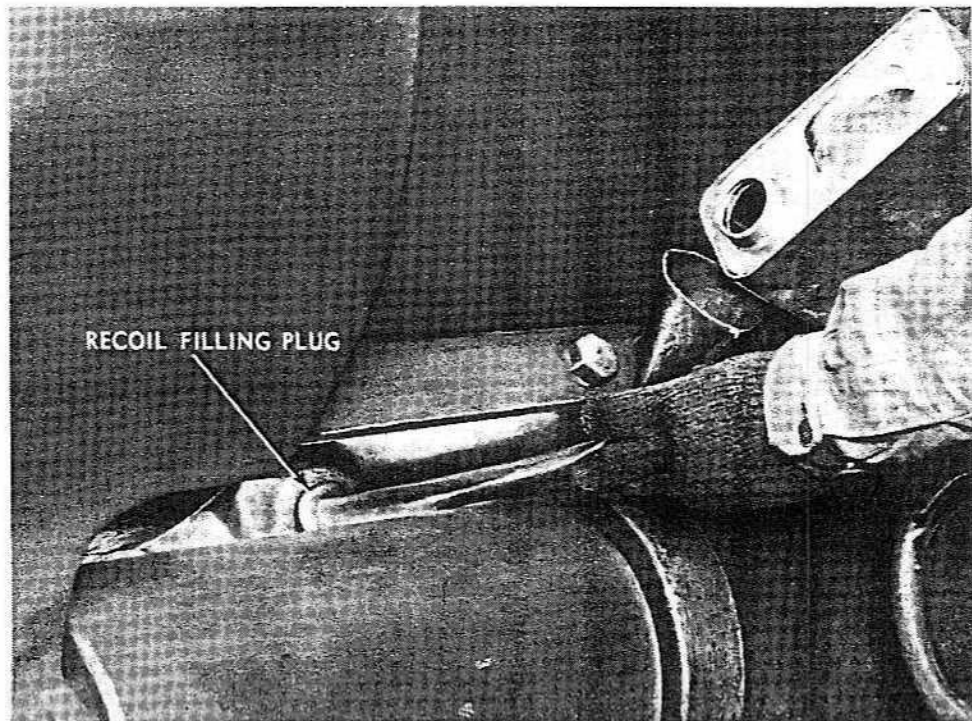

RA PD 39904

Figure 44 — Filling Recoil Cylinder M1900

Gun and Carriage

m. Ordnance maintenance personnel should be called for the servicing of yoke bearing and thrust bearing. Thoroughly clean bearing rollers and roller path with rust-preventive compound, and lubricate with prescribed lubricant.

n. Lubricate the gun and carriage as prescribed in Lubrication Order. Drain and refill gear cases to assure prescribed operating level.

o. Inspect gun, carriage, all equipment, and accessories. Inspection and adjustment to be made as listed in section VII.

40. CLEANING AND PRESERVING MATERIALS.

a. The following cleaners, abrasives, and preservatives are required for use with this materiel. See TM 9-850 for detailed information.

(1) LUBRICATING AND PRESERVING MATERIALS.

COMPOUND, rust-preventive, heavy	OIL, engine, SAE 10 OIL, engine, SAE 30
COMPOUND, rust-preventive, light	OIL, lubricating, for aircraft instruments and machine guns
COMPOUND, rust-preventive, thin film	OIL, lubricating, preservative, medium
GREASE, graphited, light	OIL, lubricating, preservative, special
GREASE, O.D., No. 00	
GREASE, O.D., No. 0	OIL, recoil, light

(a) *O.D. Grease (No. 00 and 0)*. Used in pressure lubrication fittings and gear cases.

(b) *Engine Oil (SAE 10)*. Used on sliding surfaces of breech and firing mechanism and all sliding surfaces of gun and carriage when the average daily temperature is below 32° F.

(c) *Engine Oil (SAE 30)*. Used on sliding surfaces of breech and firing mechanism and all sliding surfaces of gun and carriage when the average daily temperature is above 32° F.

(d) *Lubricating Oil for Aircraft Instruments and Machine Guns*. This oil is used to lubricate delicate bearings of fire control and sighting instruments, unless otherwise prescribed, by applying from the dropper attached to the bottle or from a piece of clean wire. In oiling of fire control instruments, use only one to two drops, as excess may run into the optical elements of the instrument and require complete disassembly to remove the excess oil.

(e) *Lubricating Grease (Special)*. Used on fire control instruments wherever a grease is indicated.

Gun and Carriage

(2) CLEANERS AND ABRASIVES.

ALCOHOL, ethyl	PAPER, lens tissue
BURLAP, jute	SOAP, castile
CLOTH, abrasive, aluminum-oxide	SOAP, liquid lens cleaning
CLOTH, crocus	SODA ASH
CLOTH, wiping, cotton	SOLVENT, dry-cleaning
PAPER, flint, sandpaper, No. 1/2	SPONGE, cellulose, type A
PAPER, flint, sandpaper, No. 1	SPONGE, natural, class A
PAPER, flint, sandpaper, No. 2	WASTE, cotton, colored
	WASTE, cotton, white

Section VII**INSPECTION AND ADJUSTMENT****41. GENERAL.**

a. Inspection has as its purpose the detection of conditions which might cause improper performance. Such conditions may be caused by:

- (1) Mechanical deficiencies resulting from ordinary wear, breakage, or exposure to the elements or enemy fire.
- (2) Faulty or careless operation.
- (3) Improper care, such as inadequate lubrication, inadequate protection, or insufficient preservative measures.

b. Inspection should always be accompanied by corrective measures to overcome any deficiencies found. When properly carried out, inspection and necessary corrective maintenance will insure the maximum reliability and performance of the materiel. The inspection outlined in this section of this manual should be made at regular intervals, not to exceed 30 days during both active and inactive seasons.

c. Before inspecting particular points, the gun and carriage should be inspected for evidences of faulty operation, care, or maintenance. Any unusual conditions which might result in improper operating or damage to the materiel will be immediately remedied. Untidy appearance and evidences of rust or deterioration will be corrected. Missing or broken apparatus will be replaced.

42. GUN.

Inspection	Adjustment
a. Bore. Note condition of the bore. Look for rust on the lands and carbon deposits in the grooves.	a. Remove rust or carbon deposits. Clean and oil.

*Gun and Carriage***Inspection**

b. **Gas Check Pad Seat.** Examine the gas check pad seat for burs or roughness.

c. **Recoil Slide Surfaces.** Note condition of slide surfaces on the barrel. Look for rust and scoring.

43. FIRING MECHANISM.

a. Note action of firing mechanism slide in the slide housing.

b. Check tension of firing leaf spring.

c. Make sure that accumulations of dirt do not hold leaf away from slide.

d. Test firing mechanism by firing a friction primer. Use primer flame baffle (par. 88).

44. BREECH MECHANISM.

a. **Operation.** Note smoothness of operation of breech mechanism in opening and closing.

b. **Breechblock and Breech Recess Threads.** Examine breechblock and breech recess for burs or indentations on the threads and for rust, pitting, or other evidences of erosion.

c. **Split Rings.** Examine split rings for burs or cracks.

Adjustment

b. Remove burs or roughness with crocus cloth. If the surface cannot be smoothed in this manner, notify ordnance maintenance personnel. Do not use any other abrasive.

c. Remove rust and burs with crocus cloth, and clean with dry-cleaning solvent.

a. If the slide sticks or does not move freely, remove slide and inspect for burs or rusting. Remove burs and rust with crocus cloth.

b. Replace weak or broken spring.

c. Disassemble and clean dirty mechanism.

d. If the slide will not close over primer head or if it distorts primer head, ream out primer seat.

a. If the mechanism does not operate smoothly, disassemble, clean, and examine all parts for wear or breakage. Replace unserviceable parts. Lubricate and reassemble. If operation is still difficult, notify ordnance maintenance personnel.

b. If not possible to smooth up or clean with crocus cloth, notify ordnance maintenance personnel. Do not use any other abrasive.

c. Replace defective rings.

*Gun and Carriage***Inspection****Adjustment**

d. **Gas Check Pad.** Examine gas check pad for bruises or torn covering.

d. Replace damaged or defective gas check pad.

e. **Obturator.** Examine the obturator spindle for burs and check for longitudinal play in spindle.

e. If possible, remove burs from spindle with crocus cloth. If not possible, or play is excessive, notify ordnance maintenance personnel.

45. RECOIL MECHANISM.

a. **Recoil Cylinder.** Check recoil cylinder for proper amount of oil. At 0.0-mil elevation, the oil should be at the level of the filling hole.

a. Refill if necessary.

b. **Check Condition of Recoil Oil.** Remove a small quantity of recoil oil through the drain plug hole. Examine oil for water and rust sediment.

b. If oil is contaminated, drain, flush, and refill with clean recoil oil.

c. **Check Packing.** Look for leakage of recoil oil around piston rod.

c. Tighten recoil piston rod follower. If leak persists, notify ordnance maintenance personnel for repacking.

46. PEDESTAL AND THRUST BEARING.

a. **Check Level.** To check level of pedestal, install clinometer to bore rest inserted in muzzle of the gun. Level the gun and observe the bubble as gun is traversed.

a. If maximum error is more than 10 minutes, notify ordnance maintenance personnel for releveling.

b. **Rollers and Roller Path.** Remove manhole and inspect thrust and pivot bearings.

b. If any signs of rusting or dirt are present, clean rollers, roller path, and bearing, and lubricate.

47. ELEVATING MECHANISM.

a. **Check Level and Condition of Oil in Elevating Mechanism.** Remove level plugs and check level and condition of oil.

a. Refill if necessary. Drain and refill if oil is dirty.

*Gun and Carriage***Inspection**

b. **Check Effort To Elevate.** The effort to elevate or depress should not exceed 24 pounds as measured at the handwheel.

c. **Check Backlash.** Operate handwheel to elevate and depress.

d. **Check Rack.** Inspect the elevating rack on gun cradle and note that it is tight.

Adjustment

b. If effort is excessive, report to ordnance maintenance personnel.

c. If handwheel can be moved more than one-eighth turn without elevating or depressing, report to ordnance maintenance personnel.

d. If loosened, tighten screws.

48. TRAVERSING MECHANISM.

a. **Check Effort To Traverse.** The effort to traverse should be approximately 18 pounds as measured at the handwheel.

a. If effort is excessive, check gears, worm, and worm-wheel, also lubricate in worm housing. If source of trouble cannot be located, notify ordnance maintenance personnel.

49. ELECTRICAL EQUIPMENT.**a. Firing Circuit.**

(1) Note condition of cables.

(1) Repair frayed insulation with friction tape; replace damaged cable. Replace damaged connections and missing screws in straps and brackets.

(2) Test firing circuit. Use test lamp or fire electric primer.

(2) If firing circuit is not complete, check all wiring and connections. Notify ordnance maintenance personnel if break in circuit is not found.

b. **Lighting Circuit.** Test all lights on gun, and check trouble light.

b. Replace defective plugs or receptacles.

Section VIII**REPAIR****50. BREECH MECHANISM.**

a. **Firing Mechanism Contact Clip.** To disassemble the contact clip (fig. 40), remove firing mechanism from breechblock, turn off the knurled screw, and remove contact clip and insulation.

Gun and Carriage

b. Breech Mechanism.

- (1) All parts of the breech mechanism are replaceable without fitting. For instructions on disassembly, refer to paragraph 36.
- (2) Leaf springs may be removed from the firing leaf by driving out with a small punch and hammer.
- (3) Repairs to breech mechanism by welding, brazing, or filing are to be made by ordnance maintenance personnel.

CHAPTER 3 - SIGHTING EQUIPMENT

51. ARRANGEMENT OF SIGHTING EQUIPMENT.

a. The on-carriage sighting equipment for the 6-inch Seacoast Gun M1900, mounted on Barbette Carriage M1900 may consist of any combination of the following: Telescope Mount M1904MI or M1904MIA1 w/3-inch Telescope M1904MI or M1904MII; Telescope Mount M1904 or M1904A1 w/3-inch Telescope M1904. The Telescope M1904 will fit only the Telescope Mount M1904A1 or M1904. Two telescopes and two telescope mounts were originally required for each 6-inch Barbette Carriage M1900, one on the right side and one on the left side. All left hand sights will be removed from the carriage and replaced with a range drum for setting elevation. An azimuth circle at the base of the gun mount and a traversing vernier register horizontal angles. The azimuth scale and range drum are used for case III fire, and the range drum and telescope are used for case II fire.

b. The off-carriage sighting and fire control equipment may include any or all of the following, depending on special and local conditions and the date of installation:

Equipment	
Clinometer M1912 or M1912A1	Plotting Board M3
Gunner's Quadrant M1 (mils)	Plotting Board M1904 (Whistler-Hearn)
Gunner's Quadrant M1918 (mils)	
Bore sight	Spotting Board M3
Scale Arms M1906	Spotting Board M2
Fire Adjustment Board M1	Gun data computer
Range Correction Board M1	Percentage Corrector M1
Range Correction Board M1A1	Wind Component Indicator M1
Deflection Board M1	Set forward rule type B
	Prediction Scales M1

The above off-carriage equipment is not covered in this manual. For information refer to FM 4-15.

52. DESCRIPTION.

a. Telescope Mount M1904MIA1 (figs. 45, 46, 47) includes the cradle, open sights, and the elevation and deflection mechanisms. The cradle pivots on a fulcrum secured to the front of the sight arm. The cradle has locating surfaces and two clamps for securing the telescope. The open sight consists of a front sight of two cross pieces, and a rear peep sight secured to the rear cradle clamp. The elevation mechanism includes an elevation handwheel and elevation rack (fig. 47). The elevation rack, which is secured to the cradle, has an elevation scale graduated on its rim in 6-minute intervals from 0 to 16 degrees. Range is set in on the ungraduated range drum which is attached to the telescope on the other side of the carriage. The de-

Sighting Equipment

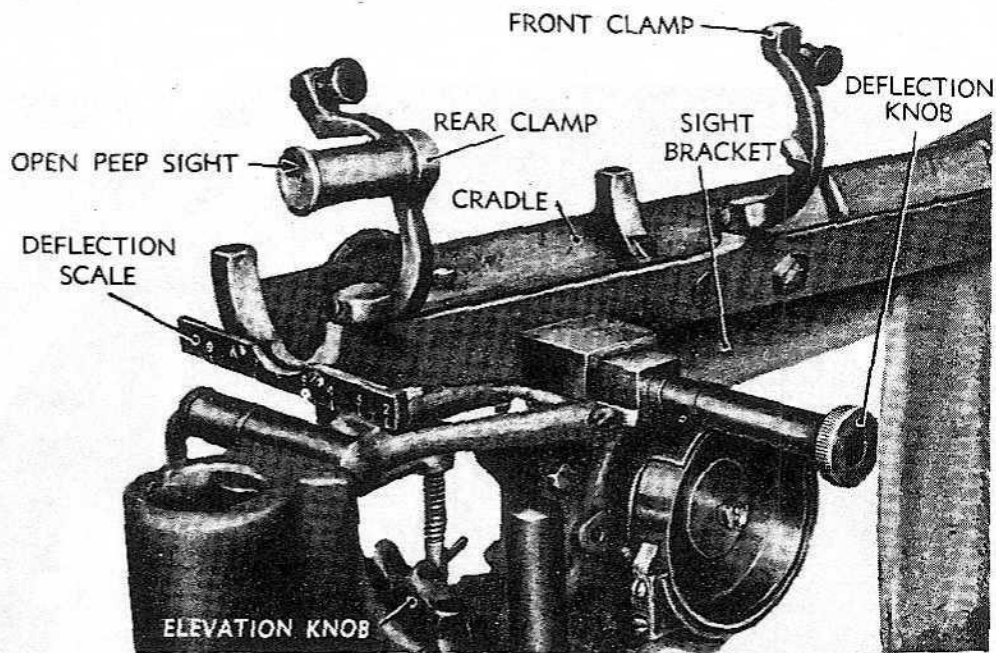

RA PD 15451

Figure 45 - Telescope Mount M1904MIA1 - Rear View

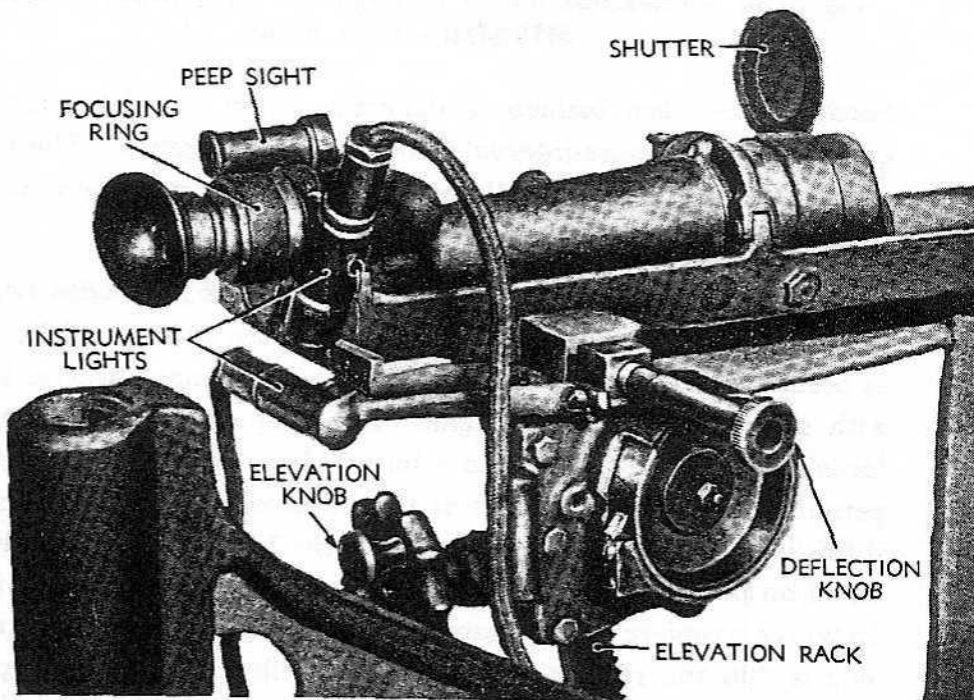

RA PD 15453

Figure 46 - Telescope Mount M1904MIA1 With 3-inch Telescope M1904MI - Side View

Sighting Equipment

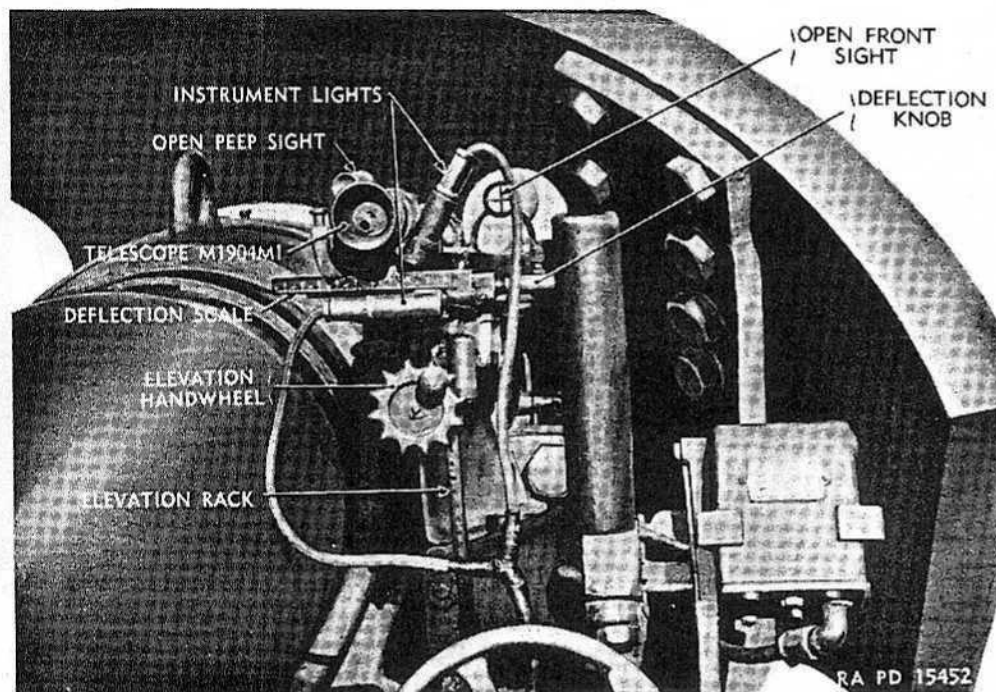
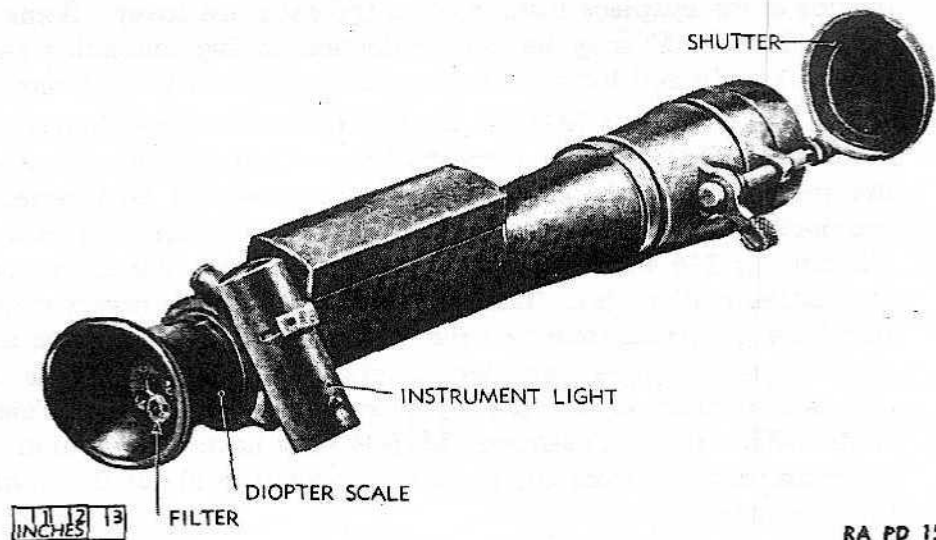

Figure 47 – Telescope Mount M1904MIA1 With 3-inch Telescope M1904MI – Rear View

flection mechanism includes a deflection knob and deflection scale graduated in 3-minute intervals from 2 to 11.5 degrees. The normal setting is 6 degrees. The illuminated deflection scale permits rapid tracking of fast moving targets.

b. The 3-inch Telescope M1904MII (fig. 46) includes two eyepieces, affording 12-power magnification for use when the light is poor as occurs around dusk and dawn, and 20-power magnification for use with normal conditions of light. The eyepieces are adjustable in focus from plus 2 diopters to minus 2 diopters. The diopter scale permits immediate setting in of the observer's individual correction if this is known. The diopter scale for the 12-power eyepiece is graduated on the outside of the eyepiece, while the diopter scale for the 20-power eyepiece is graduated on the eyepiece cover and can be seen within the rubber eyeshield. The illuminated reticle pattern consists of a modified clover leaf and cross wires. The focussing nut permits adjustment of the objective lens with respect to the reticle to avoid parallax. A shutter protects the eye of the observer. An amber filter in each eyepiece may be used to reduce glare.

Sighting Equipment



RA PD 15454

Figure 48 — 3-inch Telescope M1904 — Side View

53. DIFFERENCES BETWEEN TELESCOPE MOUNTS M1904MIA1, M1904MI, M1904A1, AND M1904.

a. The Telescope Mount M1904MI is similar to the Telescope Mount M1904MIA1 described in paragraph 52 a, except for the deflection scale which is calibrated from 1 to 5 degrees with 3 degrees as normal. Telescope Mounts M1904MI are being modified to include the wider range deflection scale of the Telescope Mount M1904MIA1.

b. The Telescope Mount M1904A1 is similar to the Telescope Mount M1904MIA1, except for the locating pads and clamps which are machined on the smaller clamping seats to fit Telescope M1904. The clamps are reversed in position so that the open peep sight is directly over the telescopic eyepiece.

c. The Telescope Mount M1904 is similar to the Telescope Mount M1904MIA1, except for the deflection scale which is calibrated from 1 to 5 degrees with 3 degrees as normal. Telescope Mounts M1904 are being modified to include the wider range deflection scale of the Telescope Mount M1904MIA1. The locating pads and clamps on the Telescope Mount M1904 are machined to fit the smaller clamping seats on the Telescope M1904. The clamps on Telescope Mount M1904 are reversed in position and the open peep sight is directly over the telescope eyepiece.

54. DIFFERENCES BETWEEN TELESCOPES M1904MII, M1904MI, AND M1904.

a. The Telescope M1904MI (fig. 46) is similar to the Telescope M1904MII described in paragraph 52 b, with the exception of the diopter scale for the 20-power eyepiece which is graduated on the

Sighting Equipment

outside of the eyepiece instead of on the eyepiece cover. Some Telescopes M1904MI may have a projection or lug extending radially from the body and located at about the middle of the telescope.

b. The Telescope M1904 (fig. 48) differs in shape from the Telescope M1904MII due to a construction which permits alinement of the eyepiece with the center line of the tube, and also permits the positioning of the open peep sight directly over the eyepiece. The telescope is 3½ inches longer, and the telescope clamping surfaces are smaller in diameter. The shutter and clamps are reversed in position from the arrangement on the Telescope M1904MII. The diopter scale for the 20-power eyepiece is graduated on the outside of the eyepiece instead of on the eyepiece cover as in the Telescope M1904MII. Some Telescopes M1904 may have a projection or lug extending radially from the body and located at about the middle of the telescope.

55. OPERATION.

a. **Installing Telescope.** Remove the telescope from its carrying case, and install it in the telescope mount. Connect the reticle lamp and deflection scale lamp to the source of power. See that the eyepiece which is best suited for the prevailing light is in the telescope.

b. **Focusing the Eyepiece.** Adjust the diopter scale to focus the telescope. Remove parallax between the cross wires and objects having the approximate range required. Adjust the illumination of the cross wires and the deflection scale. Use the filter if necessary.

c. **Setting in Range and Deflection.** Set the elevation required for the range of the target on the range drum. Set any necessary deflection on the deflection scale. Operate the gun controls to bring the telescope to bear on the target. The open sights may be used initially to speed pointing.

56. TESTS AND ADJUSTMENTS.

a. The only tests and adjustments the using personnel is required to make is the bore sighting procedure described in paragraph 57. The gun should be bore sighted at regular intervals depending on service conditions.

57. BORE SIGHTING PROCEDURE.

a. **General.** The purpose of the bore sighting procedure is to test the alinement of the sighting equipment with the bore of the gun, and to provide a basis for adjustment if the sighting equipment is found to be out of alinement. The procedure is sometimes referred to as "zeroing," "targeting," or "adjustment of sights."

b. **Bore Sights.** The line which passes through the center of the bore of the gun is determined by the bore sights issued with the gun and is chosen as the reference line from which all adjustments are made. The bore sights consist of a breech bore sight and a muzzle

Sighting Equipment

bore sight. The breech bore sight is a disk with a small peep hole drilled in the center which fits accurately in the chamber of the gun. The muzzle bore sight includes a quantity of black linen cord, to be stretched tightly across the muzzle, horizontally and vertically in the notches thereon, and a web belt to be buckled around the muzzle to hold the cord in place. If the issue bore sights are not available, the removal of the firing mechanism and use of obturator spindle hole as a peep sight, may be substituted for the breech sight. In lieu of the issue muzzle sight, crossed strings may be attached across the muzzle by securing them with a rubber band, string, tape or web belt.

c. **Verification of Bore Sighting Adjustment.** With the bore sights in place, point the gun at a distant datum point, at or beyond midrange of the gun, centering the datum point with the bore sights. Set the deflection scale to normal (6 degrees for telescope mounts with deflection scale graduated from 2 to 11.5 degrees, and 3 degrees for telescope mounts with deflection scales graduated from 1 to 5 degrees) and observe the datum point through the telescope. Use the elevating knob, if necessary, to bring the datum point onto the horizontal cross wire of the telescope reticle. If the adjustment is correct, the datum point will appear exactly on the vertical cross wire.

d. **Adjustment.**

(1) If the adjustment is not correct, turn the deflection knob to bring the datum point onto the vertical cross wire. Adjust the deflection scale to read normal with the telescope in this position. To adjust the deflection scale, loosen the two fillister-head screws in the scale and shift the scale until it registers normal, and then reclamp.

(2) If the scale can not be shifted enough to read normal, loosen the four bolts and two tap bolts in the base of the sight bracket and shift the bracket. In setting up the bolts, all six should be brought to a firm bearing before any are set up tight.

58. CARE AND PRESERVATION.

a. **General.**

(1) Sighting instruments are, in general, rugged and suited for the purpose for which they have been designed. They will not, however, stand rough handling or abuse. Inaccuracy or malfunctioning may result from mistreatment.

(2) When the gun is not in use the telescope should be kept in its carrying case, and the mount should be kept covered. Never put a telescope in its case when wet; dry thoroughly. One of the eyepieces should be kept in the telescope at all times to avoid the entry of dust or moisture.

(3) Keep all locating surfaces coated with a light film of preservative lubricating oil (special) to prevent rust. Burs on the locating surfaces should be removed carefully with a fine file.

Sighting Equipment

b. Optics.

(1) To obtain satisfactory vision, the exposed surfaces of the lenses and other parts of the telescope must be kept clean and dry. Corrosion and etching of the surface of the glass can be prevented or greatly retarded by keeping the glass clean and dry.

(2) For wiping optical parts use only lens tissue paper especially intended for cleaning optical glass. Use of cleaning cloths is not permitted. To remove dust, brush the glass lightly with a clean camel's-hair brush and rap the brush against a hard body in order to knock out the small particles of dust that cling to the hairs. Repeat this operation until all dust is removed. With some instruments an additional brush with coarse bristles is provided for cleaning mechanical parts. It is essential that each brush be used only for the purpose intended.

(3) Exercise particular care to keep optical parts free from oil and grease. Do not wipe the lenses or windows with the fingers. To remove oil or grease from optical surfaces, apply ethyl alcohol or liquid lens-cleaning soap with a tuft of lens tissue paper and rub the surface gently with clean lens tissue paper. If ethyl alcohol or lens-cleaning liquid soap is not available, breathe heavily on the glass and wipe it off with clean lens tissue paper; repeat this operation several times until the lens is clean.

(4) Moisture may condense on the optical parts of the instrument when the temperature of the parts is lower than that of the surrounding air. This moisture, if not excessive, can be removed by placing the instrument in a warm place. Heat from strongly concentrated sources should not be applied directly, as it may cause unequal expansion of parts thereby resulting in breakage of optical parts or inaccuracies in observation. Too much heat also destroys the cement between lens. To clean the lens when temperatures below +32° F prevail, use only ethyl alcohol. Do not breathe upon the glass.

CHAPTER 4 - AMMUNITION**59. GENERAL.**

a. Ammunition for the 6-inch Gun M1900, is of the separate-loading type. The loading of a complete round requires three operations: loading the projectile, the propelling charge, and the primer. These components are shipped separately. Armor-piercing projectiles for this gun are shipped fuzed; high-explosive and practice projectiles are shipped unfuzed. The fuze is assembled to the round just prior to firing.

60. FIRING TABLES.

a. Applicable firing tables are FT 6-C-2; FT 6-D-2, C 3; FT 6-E-2, C 1.

61. CLASSIFICATION.

a. Dependent upon the type of projectile, ammunition for the 6-inch Gun M1900 is classified as high-explosive, armor-piercing, target practice, and dummy. High-explosive shells are comparatively thin-walled and contain a high-explosive bursting charge. They are intended principally for fragmentation or mining effect. The armor-piercing projectiles (shell and shot) are thick-walled and contain a high-explosive bursting charge. They are designed for penetration of armor plate. Target practice projectiles, which are of the same size, shape, and weight as service projectiles, contain either an inert filler or no filler. Dummy projectiles which are completely inert, are intended for practice in loading and handling.

62. IDENTIFICATION.

a. **General.** Ammunition and components are completely identified by means of the painting and marking (including ammunition lot number). Other essential information is marked on the components, for example: on the projectile, the weight zone or weight and kind of filler; on the propelling charge, the weight of igniter, designation of each section, etc. See figures 49 to 60 and the following paragraphs. The muzzle velocity may be obtained from the firing table, and from the data card for each lot of propelling charges.

b. **Ammunition Lot Number.** When ammunition is manufactured, an ammunition lot number, which becomes an essential part of the marking, is assigned in accordance with pertinent specifications. In the case of separate-loading ammunition, a lot number is assigned to, and marked on, each of the components—projectile, fuze, propelling charge, and primer—as well as on all packing containers. It is required for all purposes of record, including reports on condition, functioning, and accidents in which ammunition is involved. To provide for the most uniform functioning, all of the components in any one lot of separate-loading ammunition are manufactured under as

Ammunition

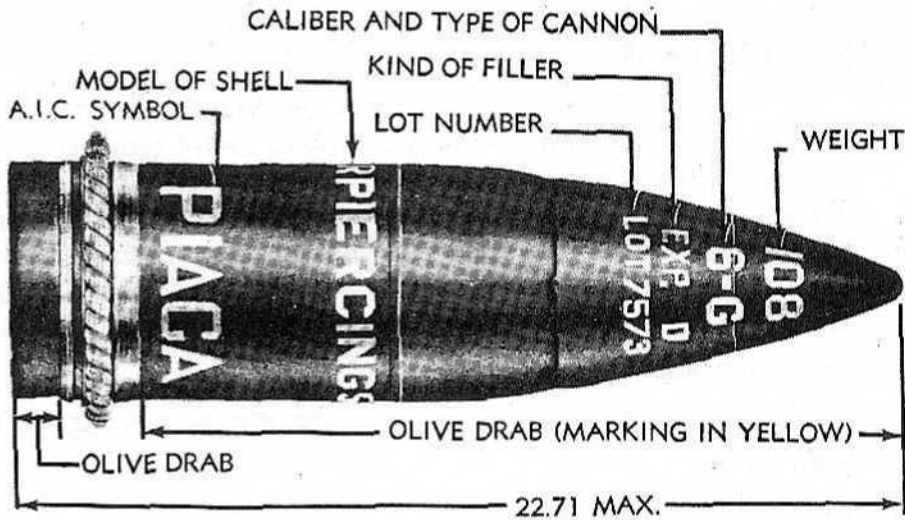

RA PD 5308B

Figure 49 — 108-lb AP Shell M1911

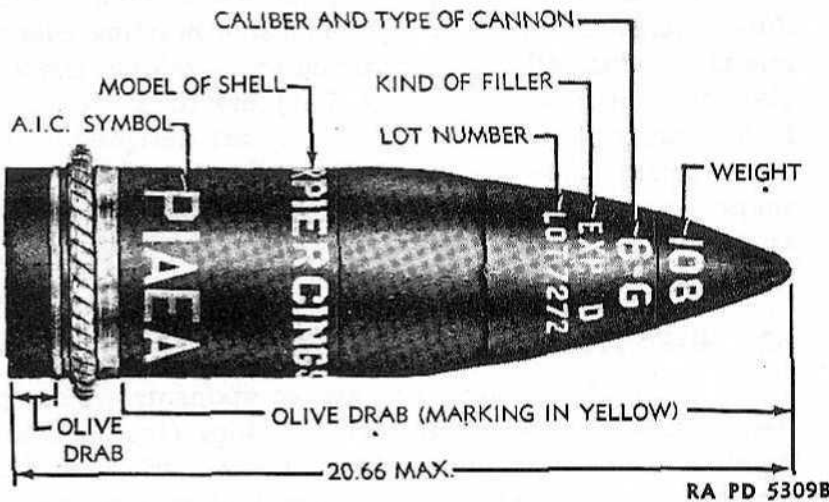

RA PD 5309B

Figure 50 — 108-lb AP Shot M1911

nearly identical conditions as practicable. For example, in the case of projectiles, any one lot consists of projectiles made by one manufacturer, loaded by one manufacturer, and of one weight. Therefore, to obtain the greatest accuracy when firing separate-loading ammunition, successive rounds should consist of:

- Projectiles of one lot number (one type and one weight).
- Propelling charges of one lot number.
- Primers of one lot number.

c. **Weight Zone Markings.** Because it is not practicable to manufacture high-explosive projectiles within the narrow weight limits re-

Ammunition

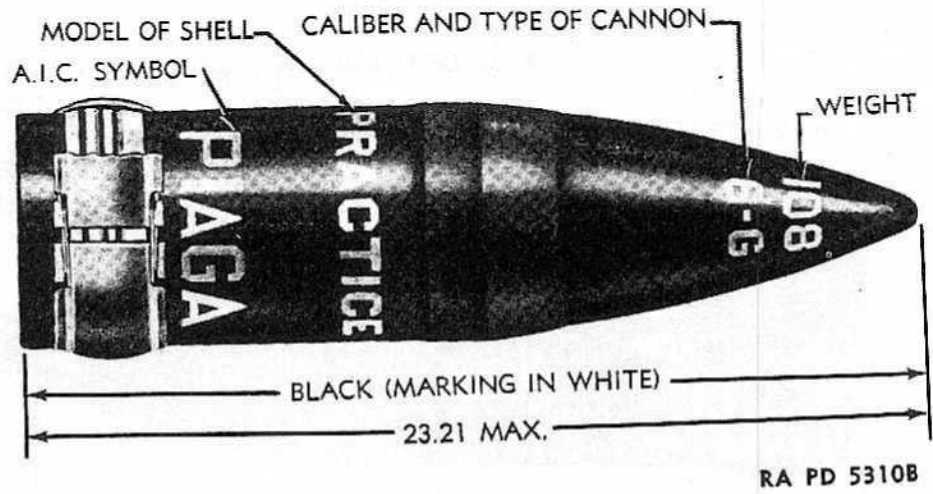

Figure 51 — 108-lb CI Shell M1911

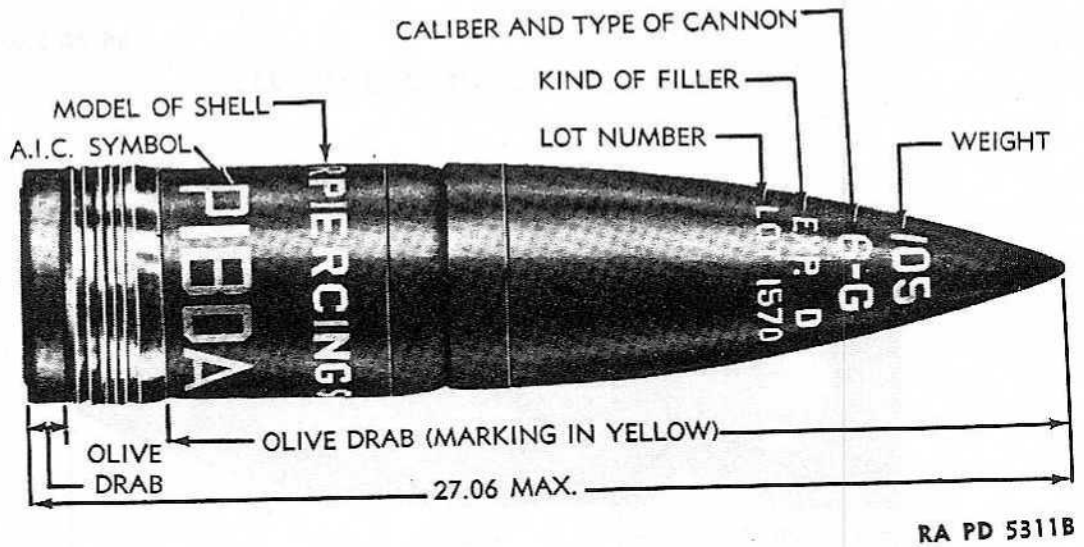

Figure 52 — 105-lb AP Shot Mk. 33

quired for the desired accuracy of fire, projectiles are grouped into weight zones in order that the appropriate ballistic corrections indicated by firing tables may be applied. The weight zone of the projectile is indicated thereon by means of squares of the same color as the markings, with a prick-punch mark in the center of each square—one, two, three, or more being used, dependent upon the weight of the projectiles. For the high-explosive shells for 6-inch guns, two squares indicate normal or standard weight. In the case of armor-piercing and practice projectiles, the actual weight to the nearest pound is stenciled thereon, rather than squares, to indicate the weight zones.

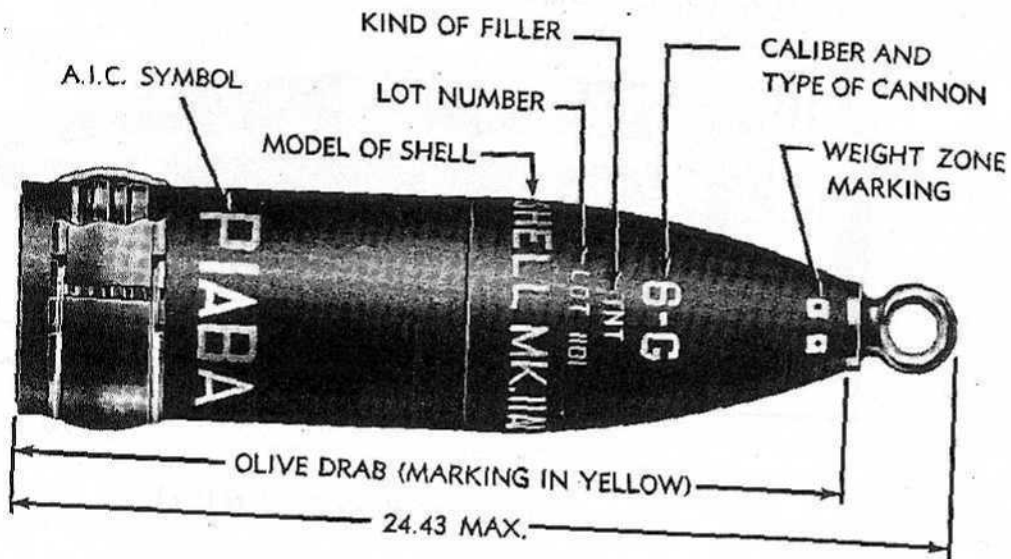

Figure 53 - 90-lb HE Shell Mk. 2A1

RA PD 53078

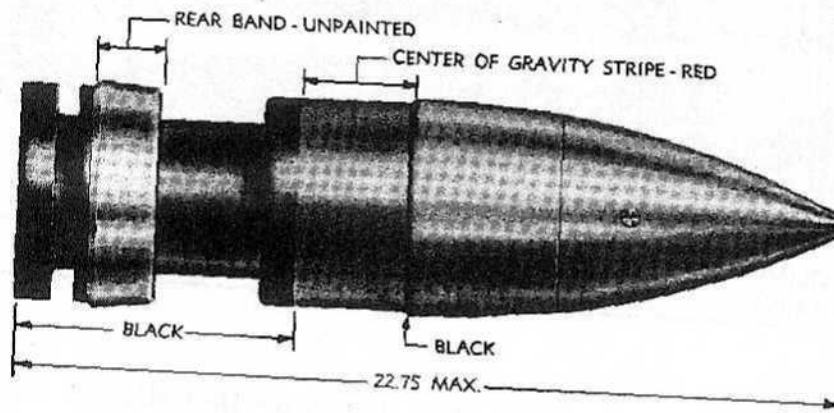

Figure 54 - 108-lb Dummy Projectile Mk. 2A1

RA PD 5313

63. CARE, HANDLING, AND PRESERVATION.

a. Ammunition components are packed to withstand conditions ordinarily encountered in the field. Armor-piercing shell and shot and dummy projectiles are packed individually in crates—the armor-piercing shot Mk. 33, being packed individually in boxes. The rotating bands of these projectiles and the Mk. 29 are protected by rope grommets. High-explosive shell are shipped uncrated with steel and fiber grommets and eyebolt lifting plugs. Practice projectiles

Ammunition

other than the Mk. 29 are shipped uncrated with grommet. Fuzes, propelling charges, and primers are packed in moisture-resistant containers. Since explosives are adversely affected by moisture and high temperature, the following precautions should be observed.

(1) Moisture-resistant seals should not be broken until ammunition is to be used.

(2) Ammunition, particularly fuzes, primers, and propelling charges, should be protected from sources of high temperature, including the direct rays of the sun. More uniform firing is obtained if the rounds are at the same temperature.

b. Do not attempt to disassemble any fuze.

c. Do not remove the eyebolt lifting plug from the unfuzed round until ready to assemble the fuze thereto. The eyebolt lifting plug is provided for convenience in handling and to keep the fuze opening free of foreign matter.

d. Primers must always be stored in a dry place. Prolonged exposure to moisture or dampness may cause malfunctioning.

e. **EXPLOSIVE AMMUNITION MUST BE HANDLED WITH APPROPRIATE CARE AT ALL TIMES. THE EXPLOSIVE ELEMENTS IN PRIMERS AND FUZES ARE PARTICULARLY SENSITIVE TO UNDUE SHOCK AND HIGH TEMPERATURE.**

f. Each of the separate loading components should be free of foreign matter—sand, mud, grease, etc.—before loading into the gun.

g. Do not remove protective or safety devices from fuzes until just before use.

h. Components of rounds prepared for firing but not fired, will be returned to their original condition and packings, and appropriately marked. Such components will be used first in subsequent firing, in order that stocks of opened packings may be kept at a minimum. Fuzes and primers will be inspected prior to repacking.

64. AUTHORIZED ROUNDS.

a. **General.** The ammunition authorized for use in the 6-inch Gun M1900 is listed in Table I below. The nomenclature (standard nomenclature) completely identifies the ammunition. Its use for all purposes of record is mandatory, except where the Ammunition Identification Code (A.I.C.) Symbol is prescribed or permitted to facilitate requisitioning and reporting in the field.

Ammunition

TABLE I. AUTHORIZED ROUNDS

PROJECTILE	FUZE FOR WHICH ADAPTED	PROPELLING CHARGE	PRIMER
Service Ammunition			
SHELL, AP, 108-lb, M1911, 6-in. guns	—	CHARGE, propelling, single section, NH powder, 6-in. guns, M1900-03-03A1-03A2-05-05A1-05A2 and M1, 90-lb and 108-lb proj.	PRIMER, electric, M30
SHELL, HE, 90-lb, Mk. 2, unfuzed, 6-in. guns	FUZE, PD, M47		
SHELL, HE, 90-lb, Mk. 2A1, unfuzed, 6-in. guns	FUZE, PD, M51† series, w/BOOSTER, M20 or M21 series*		
SHOT, AP, 105-lb, Mk. 33, w/FUZE, BD, M60, 6-in. guns, M1900-03-03A1-03A2-05-05A1-05A2 and M1	—	CHARGE, propelling, single section, NH powder, 6-in. guns, M1900-03-03A1-03A2-05-05A1-05A2 and M1, 105-lb proj.	
SHOT, AP, 108-lb, M1911, 6-in. guns	—	CHARGE, propelling, single section, NH powder, 6-in. guns, M1900-03-03A1-03A2-05-05A1-05A2 and M1, 90-lb and 108-lb proj.	
Practice Ammunition			
PROJECTILE, target practice, 105-lb (Navy), Mk. 29, 6-in. guns, M1900-03-03A1-03A2-05-05A1-05A2 and M1	—	CHARGE, propelling, single section, NH powder, 6-in. guns, M1900-03-03A1-03A2-05-05A1-05A2 and M1, 105-lb proj.	PRIMER, electric, M30
SHELL, CI, 108-lb, M1911, 6-in. guns	—	CHARGE, propelling, single section, NH powder, 6-in. guns, M1900-03-03A1-03A2-05-05A1-05A2 and M1, 90-lb and 108-lb proj.	
SHELL, empty, for sand loading, 90-lb, Mk. 2, unfuzed, 6-in. guns	FUZE, inert, PD, M47		
Dummy (Drill) Ammunition			
PROJECTILE, dummy, 90-lb, Mk. 1 or Mk. 1A1, 6-in. gun	—	CHARGE, propelling, dummy, single section, 32-lb, M1917, 6-in. guns, M1900-03-03A1-03A2-05-05A1-05A2 and M1	PRIMER, electric, M30**
PROJECTILE, dummy, 108-lb, Mk. 2 or Mk. 2A1, 6-in. gun			
Subcaliber Ammunition			
See paragraph 68.			

*FUZE, PD, M51, w/BOOSTER, M20A1 or M21; M51A1, w/BOOSTER, M20A1 or M21A1; M51A3, w/BOOSTER, M21A2; or M51A4, w/BOOSTER, M21A4.

**A fired service primer is used for drill purposes.

†The following limitations apply to the M51 fuze, and modifications: FUZE, PD, M51 or M51A1, w/BOOSTER, M20A1, are authorized for service and practice purposes. Their use for service firing will be discontinued when sufficient supply of Fuzes M51A3 with Boosters M21A2, or Fuzes M51A4 with Boosters M21A4 become available. FUZE, PD, M51, w/BOOSTER, M21, or FUZE, PD, M51A1, w/BOOSTER, M21A1, for emergency combat use only; must be drop-tested before use.

Ammunition

b. **Projectiles.** Characteristics of projectiles authorized for use in this weapon are given in Table II.

c. **Propelling Charges.**

(1) **SINGLE-SECTION PROPELLING CHARGE FOR 90-LB AND 108-LB PROJECTILES.** This charge, a single-section type (fig. 55), consists of a laced cloth bag containing NH (nonhygroscopic) smokeless powder. An igniter of black powder, encased in red cloth, is assembled to each end of the charge. The weight of this charge is approximately 33 pounds. The bag is $6\frac{3}{8}$ inches in diameter and $42\frac{3}{8}$ inches in length (maximum). The total igniter charge consists of 10 ounces of black powder; 3 ounces are contained in each of the igniter pads and the other 4 ounces are in a core igniter. The following marking is stenciled on the charge:

Each End	Side
3-OZ IGNITER	WT. 1 CHG. XX LB. (Differs with powder lot and projectile weight)
WITH 4-OZ CORE	
A-1 BLK. PDR. LOT XX	1 CHG. 6-IN. G. M1900, M1903, & M1905 XX-XX LOT XX XXX XX (Type of powder, initials of manufacturer, serial number of lot and year of manufacture)
6-IN. G. M1900, M1903 & M1905	
XX-XX (Month and year of loading)	

(2) **SINGLE-SECTION PROPELLING CHARGE FOR 105-LB PROJECTILE.** For description of this charge see foregoing paragraph. This charge, however, weighs approximately 37 pounds. It is authorized for use with the target practice projectile, Mk. 29, and the armor-piercing shot, Mk. 33.

(3) **32-LB DUMMY PROPELLING CHARGE M1917.** This dummy charge is used for drill purposes with all authorized dummy projectiles. The charge consists of a quantity of small hardwood and lead cylinders (simulated smokeless powder grains) or a lead-weighted hardwood cylinder contained in a laced bag of white cotton duck. A handle of the same material is attached to the end of the charge to facilitate its removal from the chamber of the gun by means of an extractor. The dummy charge for these guns weighs 32 pounds. It is $5\frac{3}{4}$ inches in diameter and 41 inches in length. It is similar in size and weight to the propelling charge illustrated in figure 55.

Ammunition

TABLE II. CHARACTERISTICS OF PROJECTILES FOR 6-INCH GUN M1900

Fig. No.	Kind	Type	Model	Weight as fired (lb)	Charge		Length		Method of shipment
					Kind	Weight (lb)	As shipped (in.)	As fired (in.)	
—	PROJECTILE	Target Practice	Mk. 29	105.	None	—	—	—	Complete, one per box
1	SHELL	AP	M1911	108.	EXP D	4.53	22.71	22.71	Fuzed, one per crate
3	SHELL	CI	M1911	108.	None	—	23.21	23.21	Complete, uncrated
—	SHELL	Empty*	Mk. 2	90.	Inert*	*	24.17	24.30	Unfuzed, uncrated
—	SHELL	HE	Mk. 2	90.	TNT	13.69	24.17	24.30	Unfuzed, uncrated
5	SHELL	HE	Mk. 2A1	90.	TNT	13.69	24.52	25.19	Unfuzed, uncrated
4	SHOT	AP	Mk. 33	105.	EXP D	2.17	27.06	27.06	Fuzed, one per box
2	SHOT	AP	M1911	108.	EXP D	1.54	20.66	20.66	Fuzed, one per crate
—	PROJECTILE	Dummy	Mk. 1	90.	None	—	23.00	—	Complete, one per crate
—	PROJECTILE	Dummy	Mk. 1A1	90.	None	—	23.00	—	Complete, one per crate
—	PROJECTILE	Dummy	Mk. 2	108.	None	—	22.75	—	Complete, one per crate
6	PROJECTILE	Dummy	Mk. 2A1	108.	None	—	22.75	—	Complete, one per crate

*The empty shell Mk. 2 is sand-loaded to weight at point of use.

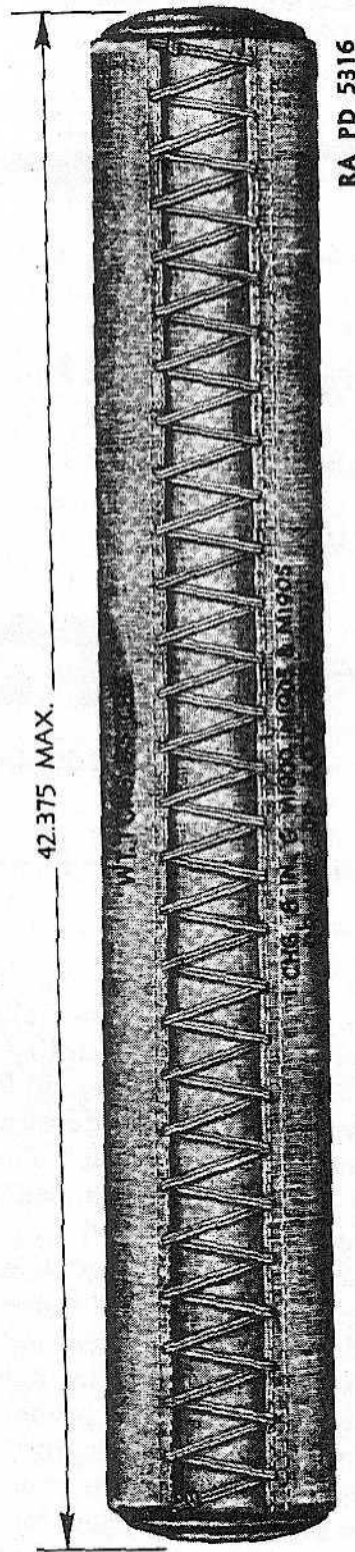

RA PD 5316

Figure 55 — Propelling Charge for 90-lb and 108-lb Projectiles

Ammunition

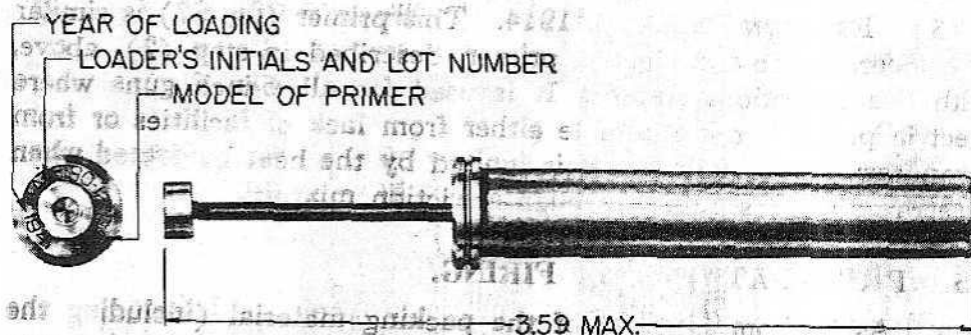

Figure 56 — Electric Primer M30

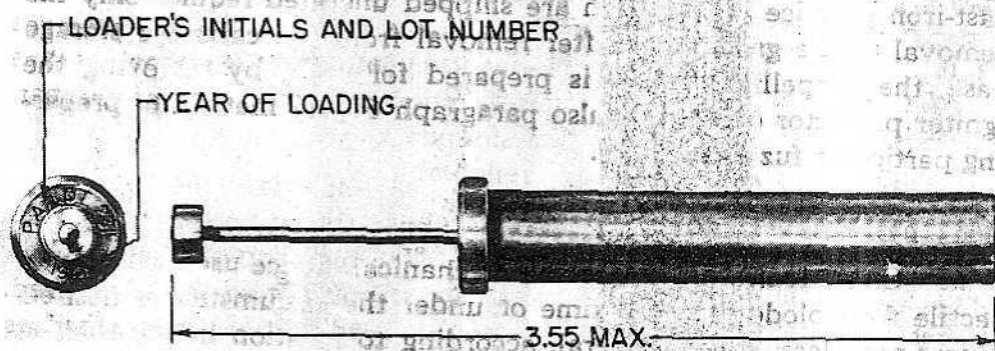

Figure 57 — Friction Primer M1914

d. Primers.

(1) **GENERAL.** The primer is the component used to fire the propelling charge. It consists, essentially, of a small quantity of sensitive explosive and a larger quantity of black powder within a brass container. The primer is designed for insertion into the breech mechanism obturator spindle and, dependent upon the type, is fired by an electric current or by friction. The symbol of the loader and the lot number of the primer are stamped on the head.

(2) **ELECTRIC PRIMER M30.** This primer (fig. 56) is used with all guns in emplacements fitted with electrical equipment. It is fired by the heat generated by an electric current passing through a resistance wire embedded in the sensitive explosive. The black powder charge intensifies and transmits the flame to the igniter, which is sewed to propelling charge. This primer may be distinguished from the friction primer, described below, by the presence of black insulation on the wire and the presence of a groove around the head of the case. A live primer is supplied for dummy rounds; it is to be fired by the service and retained for use with the dummy (drill) ammunition.

Ammunition

(3) **FRICTION PRIMER M1914.** This primer (fig. 57) is similar in appearance to the electric primer, described in step (2), above, with the exceptions stated. It is used for all 6-inch guns where electric power is not available either from lack of facilities or from temporary power failure. It is ignited by the heat generated when a serrated plug is pulled through a friction mixture.

65. PREPARATION FOR FIRING.

a. **Preparation for firing of armor-piercing projectiles.** After removal of the packing material (including the grommet which protects the rotating band), the armor-piercing projectiles are ready for firing. In the case of high-explosive shells, in addition to removing the grommet, the eyebolt lifting plug must be removed and the appropriate fuze assembled to the shell. Those cast-iron practice shells which are shipped uncrated require only the removal of the grommet. After removal from the cartridge storage case, the propelling charge is prepared for firing by removing the igniter protector caps. See also paragraph 66, for method of preparing particular fuzes for firing.

66. FUZES.

a. **Classification.** A fuze is a mechanical device used with a projectile to explode it at the time or under the circumstances desired. Fuzes are classified, in general, according to location in the shell as point-detonating or base-detonating. Fuzes authorized for use with projectiles for the 6-inch Gun M1900 are classified further—as to type of action after impact—as superquick, nondelay, and delay.

b. **Arming.** Artillery impact fuzes are so designed that they are in an "unarmed" condition before firing; they become armed by forces incident to firing.

c. **Boresafe.** Dependent upon the method of arming, some fuzes are considered "boresafe." A boresafe fuze is one in which the explosive train is so interrupted that, prior to firing and while the projectile is still in the bore of the gun, premature action of the bursting charge is prevented should any of the more sensitive elements malfunction.

d. **Base-detonating Fuze M40.** This fuze is of the base-detonating delay type. By the arrangement of the explosive elements, it is classified as a boresafe fuze. This fuze is authorized for use with projectiles for the 6-inch Gun M1900, Mk. 33. This projectile is shipped with fuze and base cover assembled, hence the fuze is not visible.

e. **Point-detonating Fuze M47.** This point-detonating fuze (fig. 58) is of the delay type and is used with high-explosive projectiles. It is not classified as boresafe. It is armed under the same conditions as boresafe fuzes. It is identified by the stamping on the body and the distinctive markings on the fuze.

Ammunition

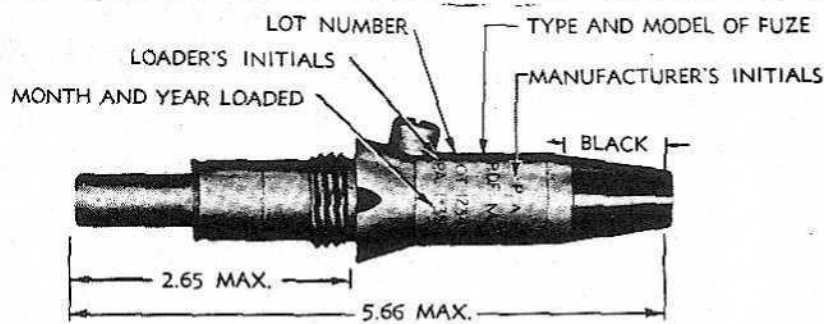

RA PD 1278A

Figure 58 — Point-detonating Fuze M47

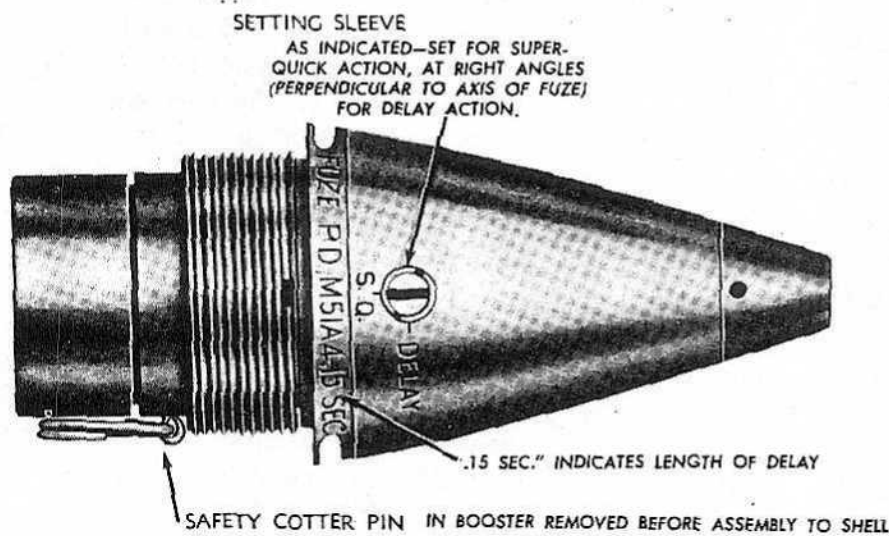

RA PD 15053A

Figure 59 — Point-detonating Fuze M51A4, w/Booster M21A4

f. Point-detonating Fuzes M51 w/Booster M21; M51A1 w/Booster M21A1; M51A3 w/Booster M21A2; M51A4 w/Booster M21A4*.

(1) GENERAL. The fuzes and boosters making up these assemblies are essentially the same in principle but differ in various respects due to modifications of either the fuze or the booster, as follows. The M51A1 differs from the M51 only with respect to the booster; the Booster M21A1 has a 1/4-inch flash hole in its rotor cover as compared with a 1/8-inch flash hole in the Booster M21. In the M51A3 and M51A4, the delay action is further modified to provide for a 0.15-second delay instead of 0.05-second as in the earlier models. The Booster M21A2 assembled to the Fuze M51A3 is also a modification of the earlier boosters, adding a set-back pin for additional insurance against premature or accidental functioning. The M21A4 is a further modification of the M21A2.

*Point-detonating Fuze M51 w/Booster M21, and the M51A1 w/Booster M21A1 are authorized for emergency combat only and must be drop-tested before use. The M51 or M51A1 w/M20A1 is authorized for service use until supplies of M51A3 w/M21A2 and M51A4 w/M21A4 become available.

Ammunition

(2) **DESCRIPTION.** In all of the fuzes (fig. 59) the booster is permanently attached to the fuze at the time of manufacture. Thereafter the fuze with booster is handled as a unit. The fuze contains two actions, superquick and delay. Although both actions are initiated on impact, the functioning of the shell depends upon the setting of the fuze. When the fuze is set "DELAY," the superquick action is so interrupted that the projectile functions with delay action. It should be noted, however, that if the superquick action malfunctions when the fuze is set "SQ," the projectile will function with delay action rather than become a dud. On the side of the fuze near the base is a slotted "setting sleeve" and two registration lines; the one parallel to the axis is marked "SQ," the other "DELAY." As shipped, the fuze is set "SQ." To set the fuze for delay action it is only necessary to turn the setting sleeve so that its slot is alined with "DELAY." A delay pellet—0.15-second in the Fuzes M51A3 and M51A4, and 0.05-second in the Fuzes M51 and M51A1—incorporated in the delay action train provides for the delay action. The setting may be made or changed at will with a screwdriver or some other similar tool any time before firing. This can be done even in the dark by noting the position of the slot—parallel to the fuze axis for superquick action, at right angles thereto for delay. A cotter pin with pull ring is assembled to the booster to prevent accidental movement of the detonator during shipment. This cotter pin is to be withdrawn just prior to assembling the fuze with booster to the projectile.

(3) **PREPARATION FOR FIRING.** To fuze the projectile proceed as follows:

(a) Remove eyebolt lifting plug from projectile.

(b) Inspect fuze cavity and threads. They should be free of foreign matter which would interfere with the proper assembly of the fuze.

(c) Remove cotter pin from booster.

(d) Screw fuze with booster into projectile by hand. Tighten with fuze wrench.

(e) Set fuze. If delay action is required, aline slot in setting sleeve with "DELAY"; if superquick, aline slot with "SQ" setting as shipped. Fuze may be reset as required.

67. PACKING.

a. Complete packing data covering dimensions, volume, and weight of the various components of the ammunition described herein are published in ORD 11 SNL P-1, P-2, P-7, P-8, and R-3. Although weights of individual projectiles and crates vary somewhat, dependent upon the type and model, and propelling charges vary likewise, dependent upon the particular powder charge, the following data are considered representative for estimating weight and volume requirement:

Ammunition

	Weight (pounds)	Volume (cubic feet)
6-inch gun projectile as shipped:		
High-explosive, uncrated ¹ *	90	0.62
Over-all dimensions (inches): 24.43 x 7.37 (diam.)		
Armor-piercing Shot, Mk. 33, and Practice Projectile, Mk. 29, packed 1 per box	124	1.53
Over-all dimensions (inches): 31 $\frac{1}{8}$ x 9 $\frac{3}{16}$ x 9 $\frac{3}{16}$		
Armor-piercing Shell, M1911, packed 1 per crate..	115	1.75
Over-all dimensions (inches): 28 $\frac{7}{16}$ x 10 $\frac{3}{8}$		
Practice, uncrated*	109	0.58
Over-all dimensions (inches): 23.21 x 7.37 (diam.)		
Propelling Charge:		
Packed 1 charge per cartridge, storage case, 1 case per crate	88	3.09
Over-all dimensions of crate (inches): 52 $\frac{1}{8}$ x 10 $\frac{1}{8}$ x 10 $\frac{1}{8}$		
Dummy propelling charges are packed and shipped in wooden boxes as required.		
Fuzes:		
FUZE, PD, M47, packed in metal-lined box, 50 fuzes per box	50.7	0.87
Over-all dimensions (inches): 18 $\frac{3}{16}$ x 9 $\frac{3}{16}$ x 8 $\frac{29}{32}$		
Point-detonating Fuze (M51 series) w/Booster (M21 series) packed in individual fiber con- tainers, 25 containers (25 fuzes) per wooden box	77.0	1.49
Over-all dimensions (inches): 17 $\frac{7}{16}$ x 15 $\frac{7}{8}$ x 9 $\frac{1}{32}$		
Primers:		
Packed 20 per metal container, 25 containers (500 primers) per box	47.8	1.06
Over-all dimensions (inches): 17 $\frac{9}{16}$ x 16 x 6 $\frac{17}{32}$		

*Note: The outside diameter given in over-all dimensions of uncrated projectiles include the grommet.

Ammunition

b. **Marking for Shipment.** Packing for shipment, and bundle packing identification and shipping plates are marked as follows:

- (1) Name and address of destination or port officer.*
- (2) Name and address of ultimate consignee (or code marking).*
- (3) List and description of contents.
- (4) Ammunition Identification Code (A.I.C.) symbol, as published in ORD 11 SNL's.
- (5) Gross weight in pounds, displacement in cubic feet.
- (6) The number of the package.*
- (7) The letters "U.S." in several conspicuous places (not mandatory).
- (8) Order number, contract number, or shipping number.
- (9) Ordnance insignium and escutcheon.
- (10) Name or designation of consignor preceded by the word "From."*
- (11) Lot number.
- (12) Month and year packed.
- (13) Inspector's stamp.

*May be omitted on individual package in carload shipments of packages of standard weights and dimensions containing standard quantities.

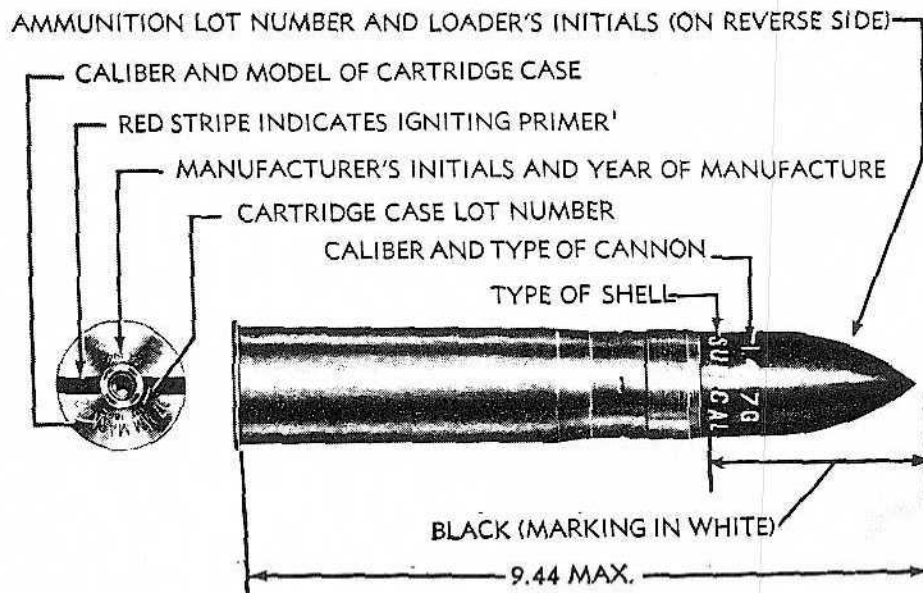

Figure 60 — 1.457-inch Subcaliber Shell RA PD 5290A

Ammunition

68. SUBCALIBER AMMUNITION.

a. **General.** The 1.457-inch subcaliber shell (fig. 60) is authorized for use in the 1.457-inch subcaliber gun when this gun is used for subcaliber practice in 6-inch seacoast guns. This ammunition is issued in the form of fixed complete rounds. "Fixed" ammunition refers to complete rounds in which the propelling charge is fixed, that is, not adjustable, and which are loaded into the gun as a unit. The projectile, which is made of steel, is inert and weighs 1.06 pounds as fired. The cartridge case is of the extracting rim type and contains an igniting primer. To distinguish this round from those containing percussion primers, a diametral red stripe is painted across the base. When firing, a regular service primer (Electric Primer M30, or friction Primer M1914) is required to fire the igniting primer of the subcaliber round. The complete round may be identified by the markings thereon.

69. FIELD REPORT OF ACCIDENTS.

a. See paragraph 2.

CHAPTER 5 – ORGANIZATIONAL SPARE PARTS AND ACCESSORIES

70. GENERAL.

a. A complete list of accessories for the gun and gun carriage is contained in the Standard Nomenclature Lists, E-4, E-16, respectively.

b. Accessories include the tools and equipment required for such disassembling and assembling as the using arm is authorized to perform, and for the cleaning and preserving of the gun, carriage, ammunition, etc. They also include chest, covers, tool rolls, and other items necessary to protect the materiel when it is not in use. Additional accessories and supplies of a general nature are provided for battery use. Accessories should not be used for purposes other than as prescribed, and when not in use should be properly stored.

c. There are a number of accessories whose names or general characteristics indicate their use. Others, embodying special features or having special uses, are described in the following paragraphs.

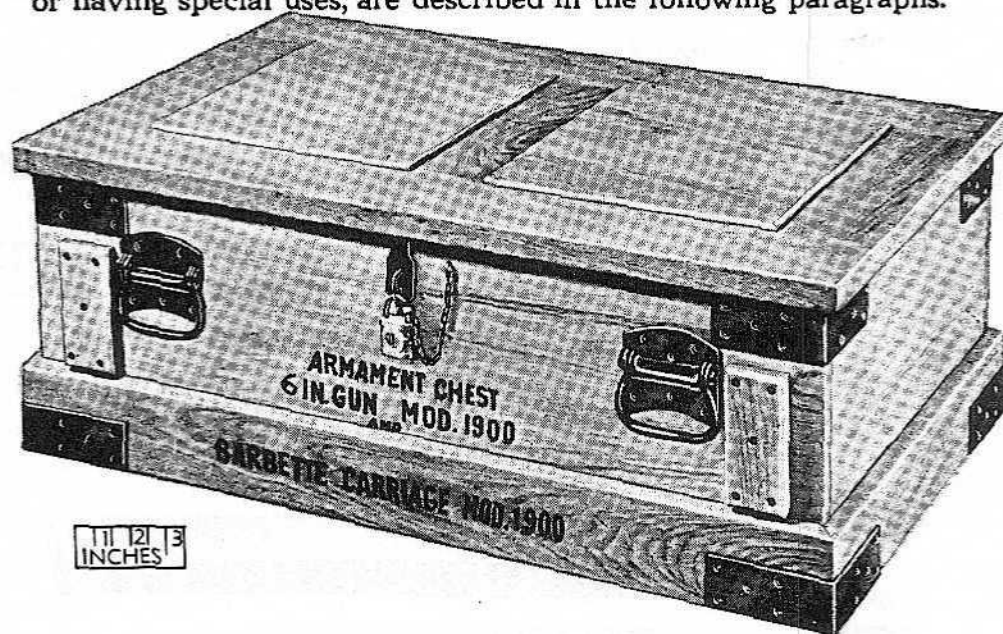

RA PD 54081

Figure 61 – Armament Chest (21-0-1)

71. ARMAMENT CHEST (21-0-1).

a. The armament chest (fig. 61) is a wooden storage chest used for storing and carrying tools and accessories for the gun and carriage. A list of accessories packed in the chest, is mounted on the inside of the lid. Receptacles, blocks and clips are provided inside the chest for the various tools. The chest is 49½ inches long, 21⅝ inches wide, and 16½ inches high (outside dimensions).

Organizational Spare Parts and Accessories

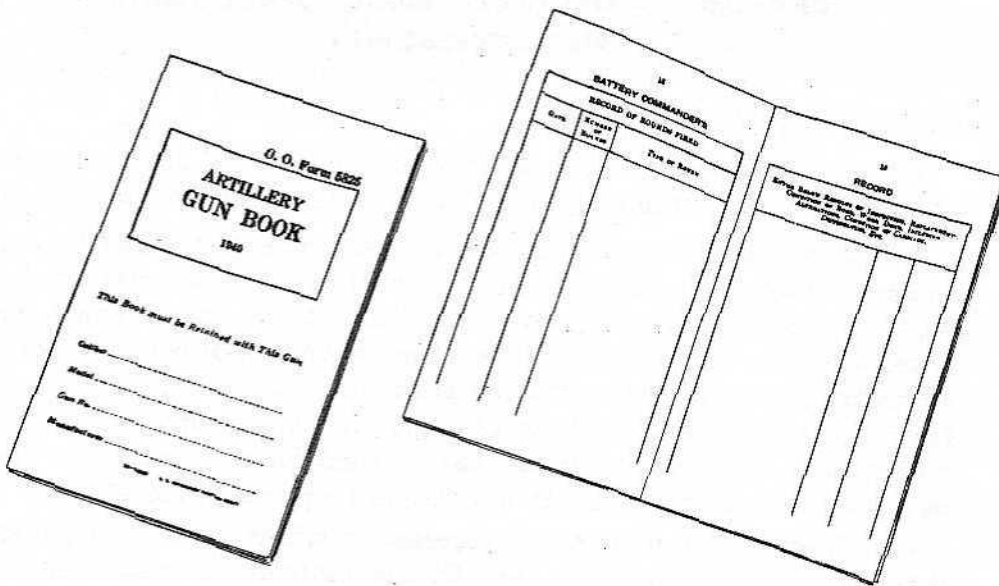

RA PD 80939

Figure 62 – Artillery Gun Book (Blank)

72. ARTILLERY GUN BOOK (BLANK).

a. The purpose and use of the Artillery Gun Book are described in paragraph 2.

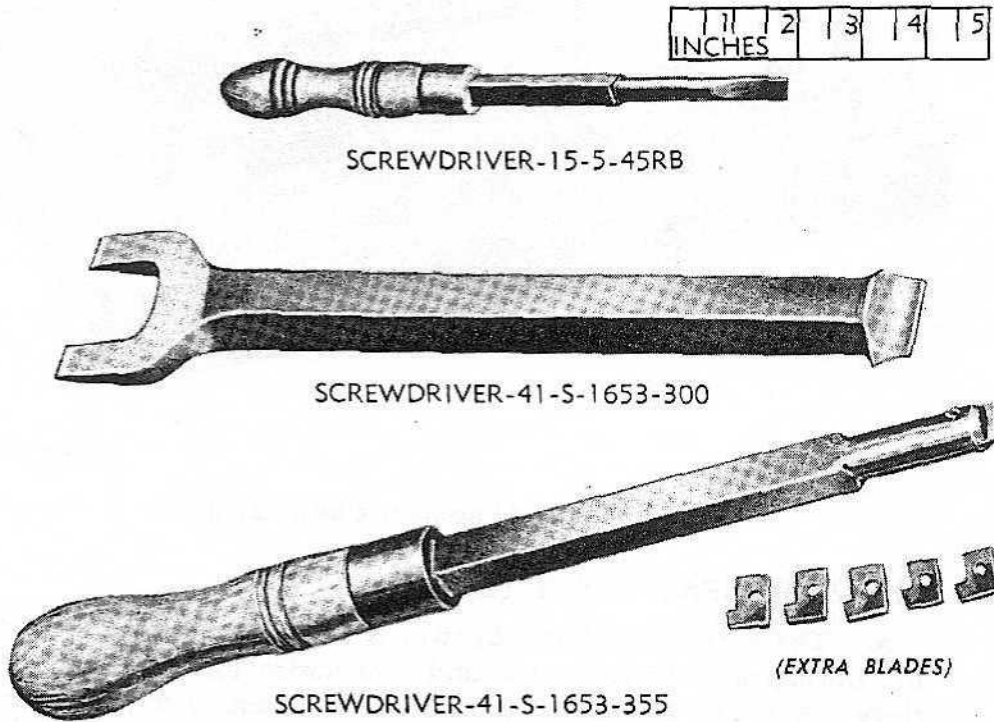

RA PD 102053

Figure 63 – Bar Screwdrivers

*Organizational Spare Parts and Accessories***73. BAR SCREWDRIVERS.**

a. Three bar screwdrivers (fig. 63) are provided for use as follows:

(1) Bar screwdriver (15-5-45RB) is used on the gear segment screws.

(2) Bar screwdriver (15-5-45W) is designed so that blade may be exchanged and is used on the latch lever pivot screw, rotating screw, tripping stud screw, and latch screw.

(3) Bar screwdriver (15-5-45U) has a blade at each end. This screwdriver is used on the obturator nut and pinion pivot screw.

74. BORE GREASING DEVICE, 6-INCH, M1 (D36174).

a. The bore greasing device (fig. 64) is used to slush the bore with corrosion preventive compound. It is 35 inches long and consists of three parts as follows:

(1) A centering disk assembly (consisting of two friction disks assembled to a spacer).

(2) A smoothing brush and spreading disk assembly (consisting of a cylindrical brush assembled to a spreading disk).

(3) A shaft assembly (consisting of a tubular shaft fitted with a collar and eye on each end; one fixed, one removable).

b. The friction disks serve as guides, keeping the shaft centered and parallel to the bore of the gun. This in turn centers the spreading disk (which spreads the slushing compound in the bore) and insures an even pressure of the brush bristles against the bore of the gun. The centering disk assembly and the smoothing brush and spreading disk assembly are free to slide on the shaft.

c. To use the bore greasing device: Attach a dragline (fig. 64) to the fixed eye on the shaft of the bore greasing device and insert the other end of the line through the bore of the gun. After removing the removable collar from the opposite end of the shaft, slip on the friction disk. These are now ready for inserting in the bore. As the first disk enters, the studs in the rim of the disk will strike against the muzzle face of the gun. Compress these studs with wooden blocks held against their ends. Do the same for the second disk. When this has been completed, push both the disks in, holding the shaft until the disks are located at the extreme end of the shaft, and the other end of the shaft extends out beyond the muzzle face of the gun, a distance equal to the thickness of the smoothing brush. This will allow the smoothing brush to be fitted on after the corrosion preventive has been applied.

(1) Pack the prescribed corrosion preventive into the muzzle end of the gun, taking care to pack solid with no air pockets. Care should also be taken to prevent the bore greasing device from being pushed breechward.

Organizational Spare Parts and Accessories

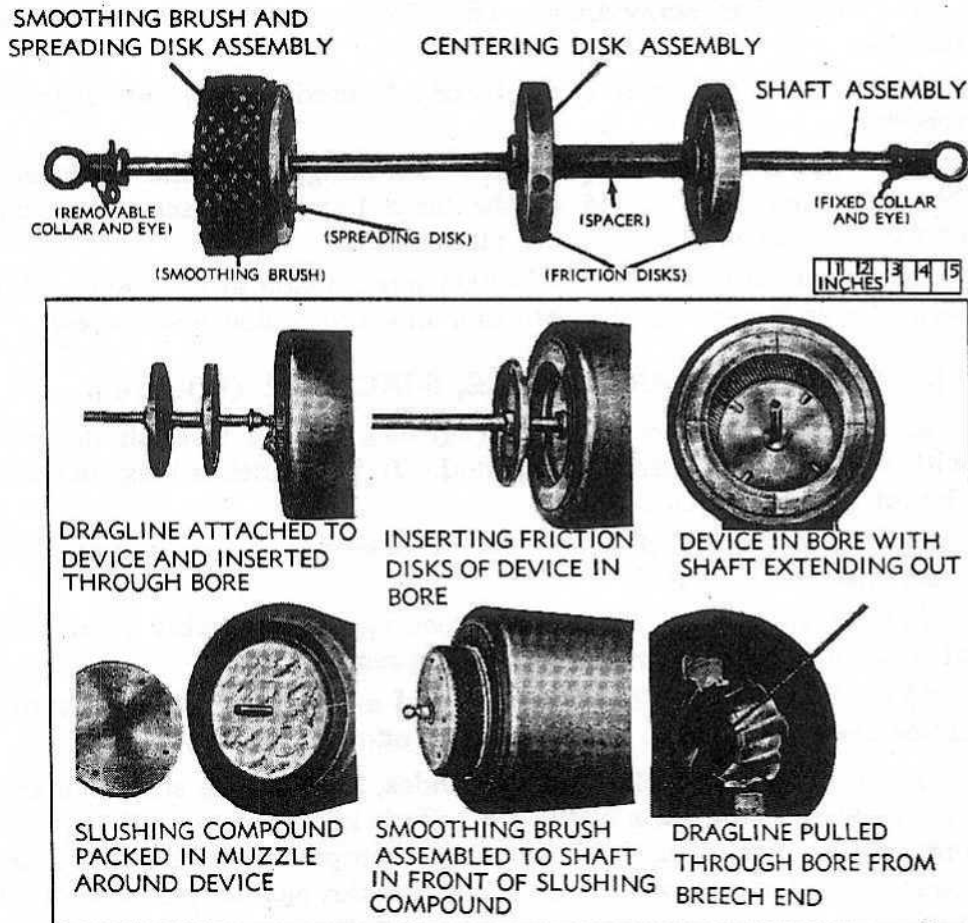

RA PD 54085

Figure 64 — Bore Greasing Device, 6-inch, M1 (D36174)

(2) Install the smoothing brush and spreading disk assembly with the spreading disk next to the corrosion preventive. At this point, coat the brush bristles with the prescribed corrosion preventive, to insure the slushing of the first few inches of the bore at the beginning of the pulling operation.

(3) By means of the dragline pull the bore greasing device and corrosion preventive through the bore of the gun. The corrosion preventive oozes out around the spreading disk and fills the grooves or rifling of the gun. After the friction disks enter the chamber, it is necessary to hold a pole or staff against the friction disk in order to slush the last several inches of rifling.

(4) The pull on the dragline may be supplied by hand or tractor. Keep the direction of the pull along the axis of the bore. Once the pulling operation is started, each stop and start will leave a heavy ring of corrosion preventive in the bore.

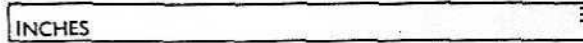
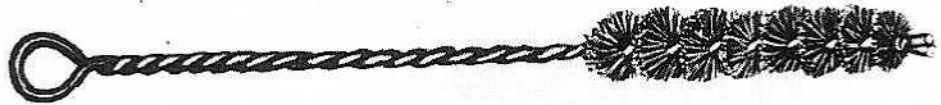

RA PD 54086

Figure 65 - Primer Seat Cleaning Brush (38-B-992-800)

NOTE: An alternate method of placing the bore greasing device in the bore is to draw it in the breech end. This can be accomplished by passing a light line through the bore from the muzzle end and attaching the line to the eye on the brush end of the greasing device. As the greasing device is being pulled through by the light line, the dragline to be used in the slushing operation is attached to the opposite end of the greasing device and drawn through at the same time.

75. BRUSHES.

a. There are three special brushes provided for use on the gun and described as follows:

(1) **PRIMER SEAT CLEANING BRUSH (38-B-992-800)** (fig. 65). This is a small twisted wire handle circular spiral brush. It is used for cleaning the primer seat.

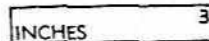
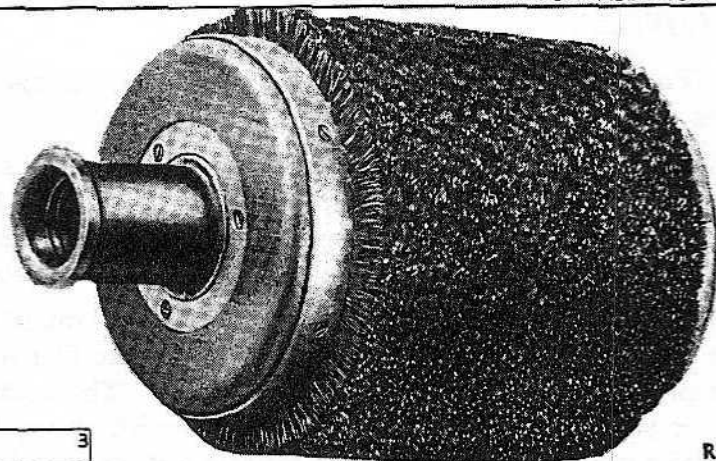
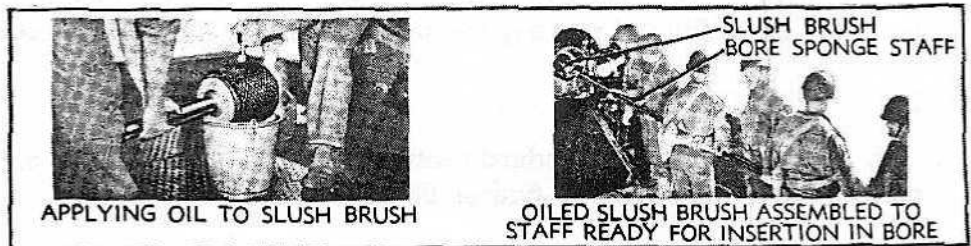

RA PD 54087

Figure 66 - Slush Brush 6-inch Gun (64-1-27) (For Staff, See Fig. 93)

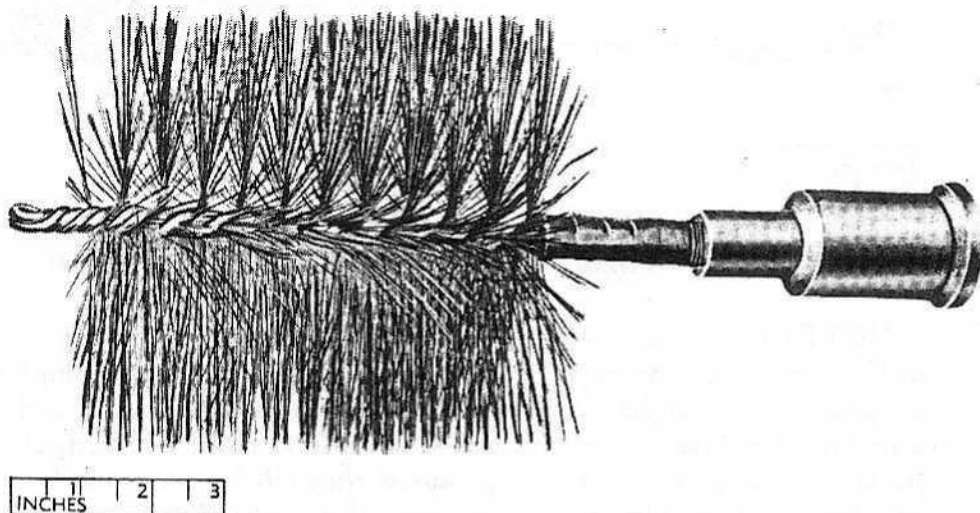

RA PD 54159

Figure 67 — Wire Cleaning Brush 6-inch Gun (64-1-31)
(For Staff, see Fig. 93)

(2) **SLUSH BRUSH (6-INCH GUN) (64-1-27)**. The slush brush (fig. 66) is a cylindrical, short-bristled brush used to coat the bore and rifling of the gun with oil to prevent rust and deterioration.

(3) **WIRE CLEANING BRUSH (6-INCH GUN) (64-1-31)**. This is a cylindrical brush (fig. 67) with long wire bristles for cleaning the gun bore and rifling of powder fouling, carbon deposits, and corrosion.

76. COMMON TOOLS.

a. The common or standard tools provided for general use on this materiel are illustrated on figures 68 and 69.

77. COVERS.

a. Three covers provided and classed as accessories for the gun are described below:

(1) **BREECH COVER M9 (38-3-59) (fig. 70)**. It is made of olive-drab cotton duck designed to fit over the breech for its protection when not in use. One end is open and split along the side so that it may be slipped over the breech and strapped in place.

(2) **MUZZLE COVER M24 (38-3-97)**. The muzzle cover (fig. 71) is made of olive-drab cotton duck designed to fit over the muzzle for its protection when the gun is not in use. The cotton duck patterns are sewed to form a cylindrical cover with one end open. The open end may be slipped over the muzzle and strapped in place with a cotton webbing strap. The closed-end is provided with a cotton webbing grip handle for pulling the cover from the muzzle.

Organizational Spare Parts and Accessories

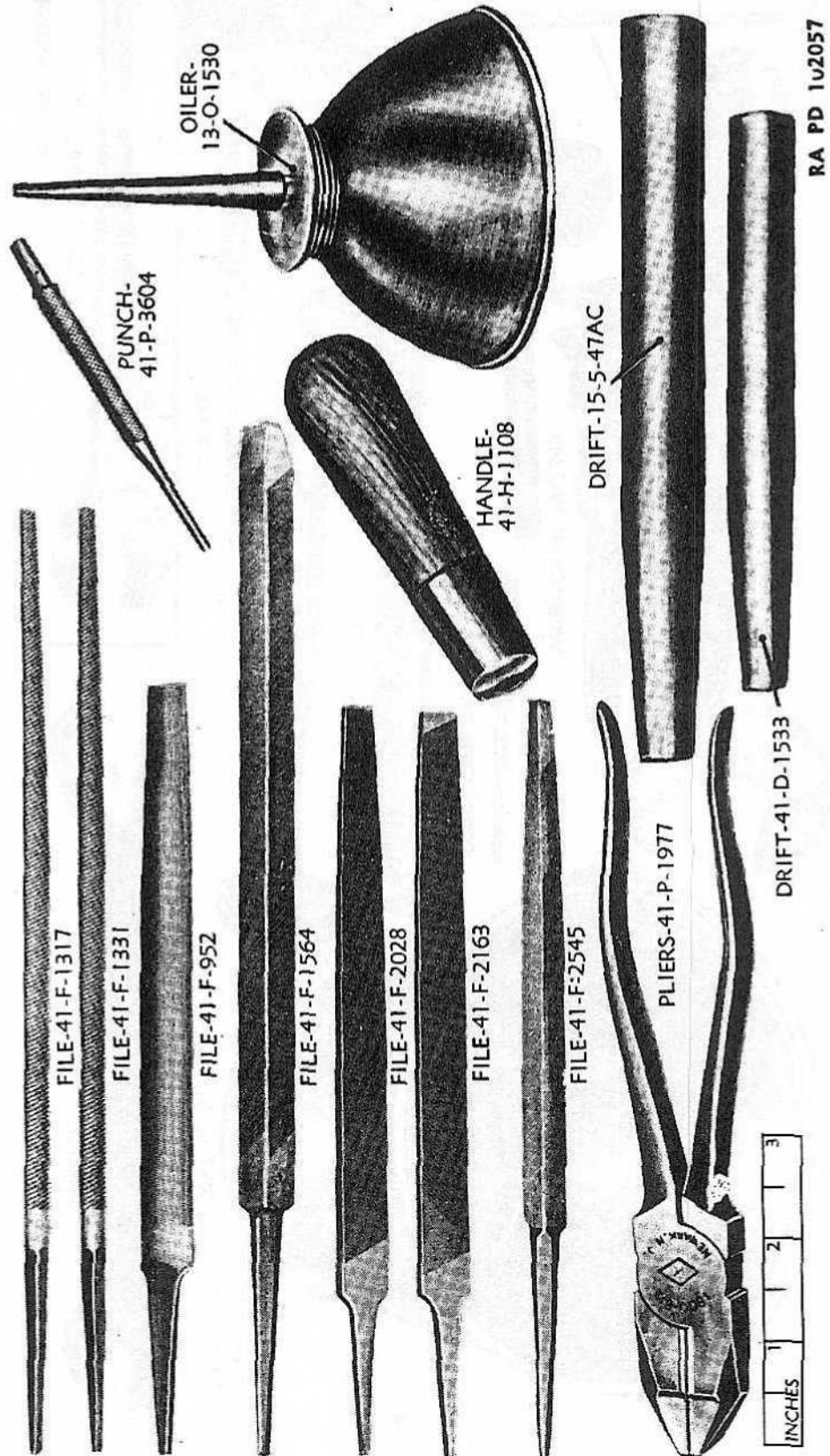

Figure 68 — Common Tools

Organizational Spare Parts and Accessories

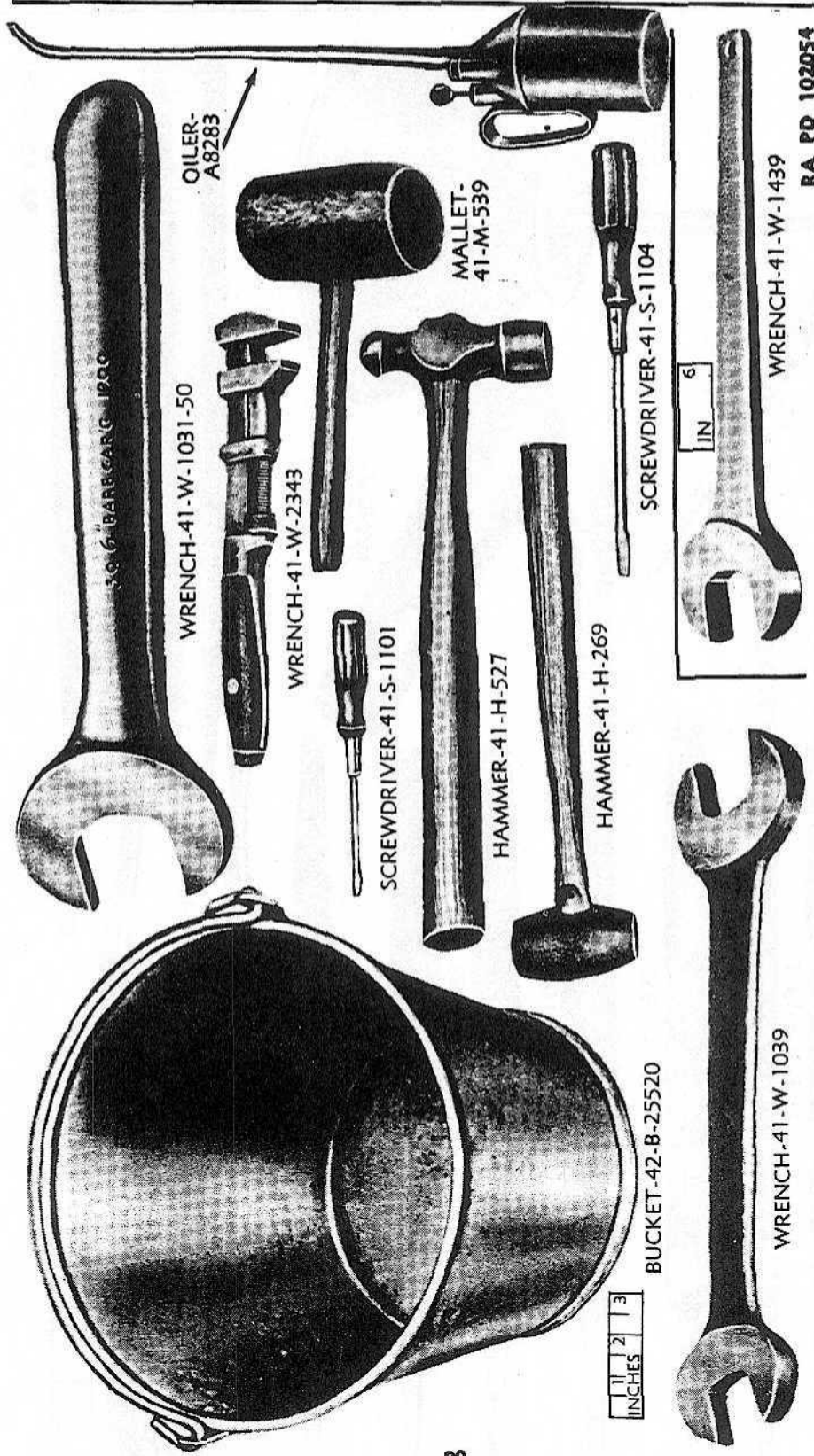
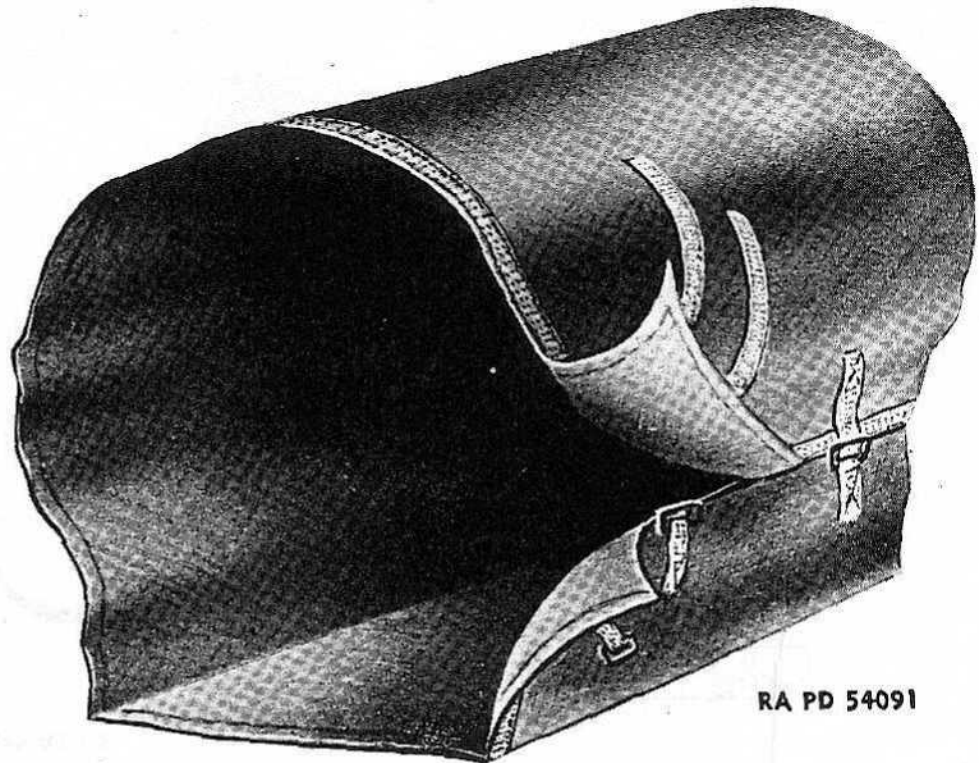

Figure 69 — Common Tools



RA PD 54091

INCHES 6

Figure 70 – Breech Cover M9 (38-3-59)

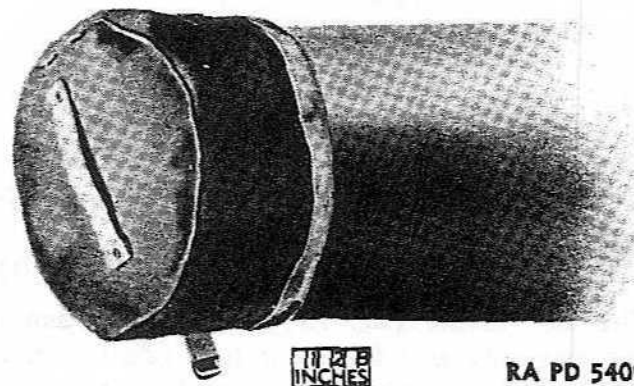

RA PD 54092

INCHES 1 1/2

Figure 71 – Muzzle Cover M24 (38-3-97)

(3) **SPONGE COVER (38-5-2BA)**. This cover (fig. 72) is made of olive-drab cotton duck and is cylindrical in shape. It is designed to protect the bore sponge from dirt and grit when it is not being used. The bottom or closed end is provided with cotton webbing loop handle for carrying, or for holding the cover, when the bore sponge is pulled from the cover. The open end may be closed with a draw string.

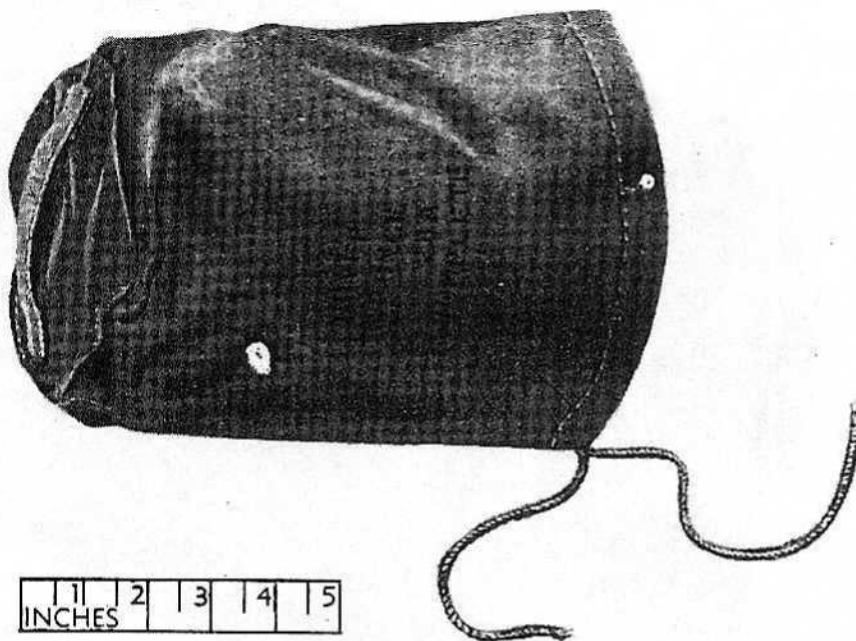

RA PD 54093

Figure 72 - Sponge Cover (38-5-2BA)

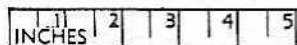

RA PD 54094

Figure 73 - File Cleaner (W/Scorer) (38-C-300)

78. FILE CLEANER (W/SCORER) (38-C-300).

a. The file cleaner (fig. 73) is a flat wooden brush with wire bristles on one side and fabric or hair bristles on the other. It is used to clean steel dust and shavings from the teeth of files. It is provided with a steel scorer, which is attached to the cleaner's handle and is used to clean out the teeth of the files when the brush fails to do so.

79. FILLING FUNNEL (15-5-46D).

a. This is a copper funnel (fig. 74) with a bent spout for filling the recoil cylinder. The mouth of the funnel is 3 inches in diameter. The spout is bent at a 45-degree angle from the funnel. The lower end of the spout has a collar and groove to allow the air to escape

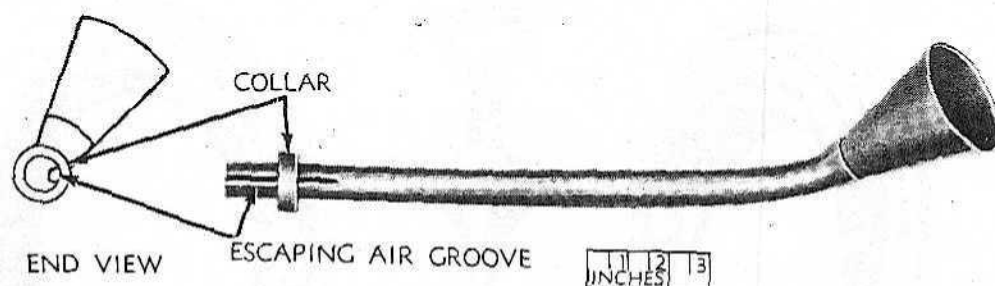

RA PD 54095

Figure 74 — Filling Funnel (15-5-46D)

from the recoil cylinder and to prevent the funnel from bubbling over when oil is poured in through the funnel into the cylinder.

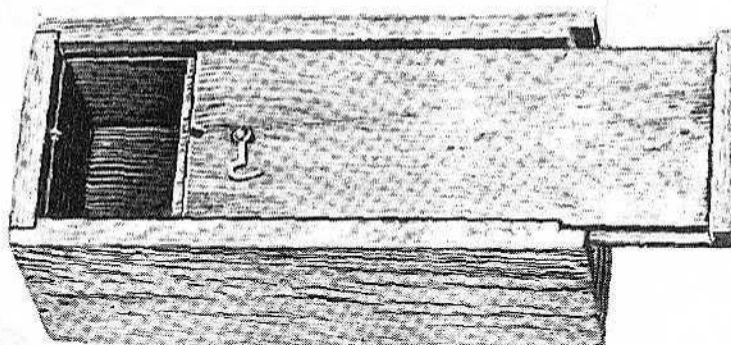

RA PD 54096

Figure 75 — Firing Mechanism Box (76-7-15)

80. FIRING MECHANISM BOX (76-7-15).

a. This is a small, rectangular, oak box (fig. 75), with a sliding lid and various compartments for housing the firing mechanism, the primer seat cleaning reamer, and three primer seat cleaning brushes.

81. FORCE PUMP (PLUMBER'S) (11-P-430).

a. The plumber's force pump (fig. 76) is a hand pump with two hoses used to flush and clean the recoil cylinder. The pump has a foot rest to steady the pump when being operated. Its handle connects to the plunger. It has a 10-foot rubber suction hose. The discharge hose is 15 feet long. Dry-cleaning solvent is forced under by the pump into the recoil cylinder for cleaning the interior before refilling with new recoil fluid. The pump is also used to clean the traversing rollers of the carriage.

Organizational Spare Parts and Accessories

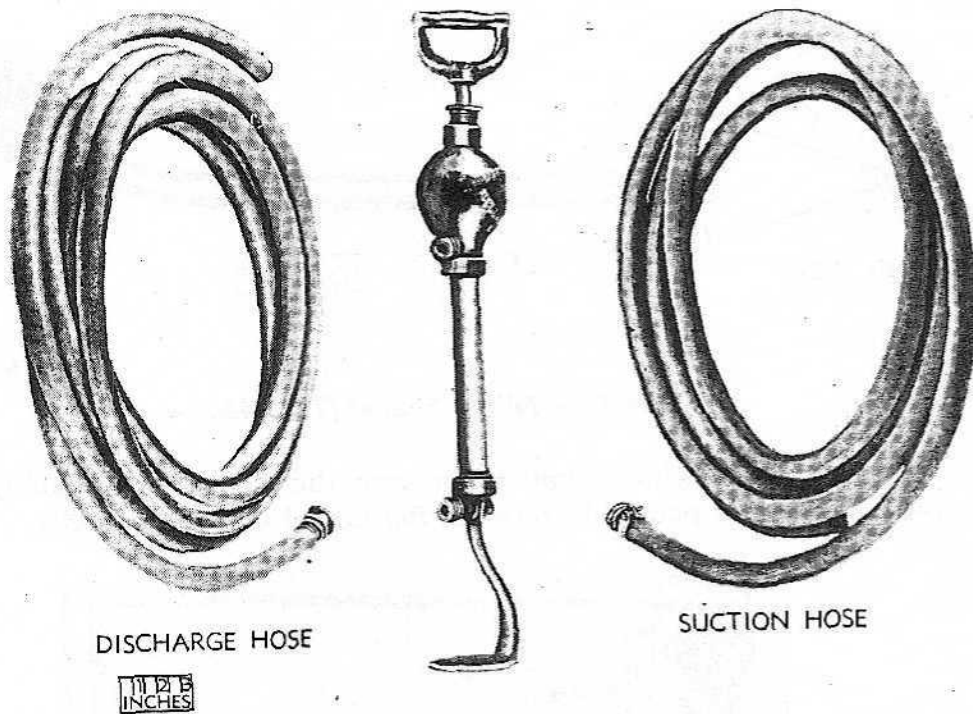

RA PD 54097

Figure 76 – Force Pump (Plumber's (11-P-430)

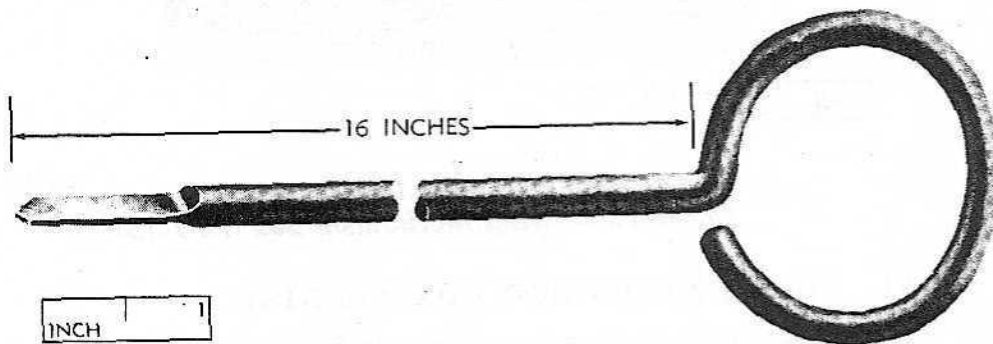

RA PD 54098

Figure 77 – Gunner's Drill (15-5-47W)

NOTE: Make sure that all solvent in the pump and hoses, is allowed to evaporate before storing.

82. GUNNER'S DRILL (15-5-47W) (fig. 77).

- a. This is a stiff wire with a small loop handle at one end and a sharp chisel blade at the other. It is used to run through and drill or clean out the primer vent of any carbon or residue.

Organizational Spare Parts and Accessories

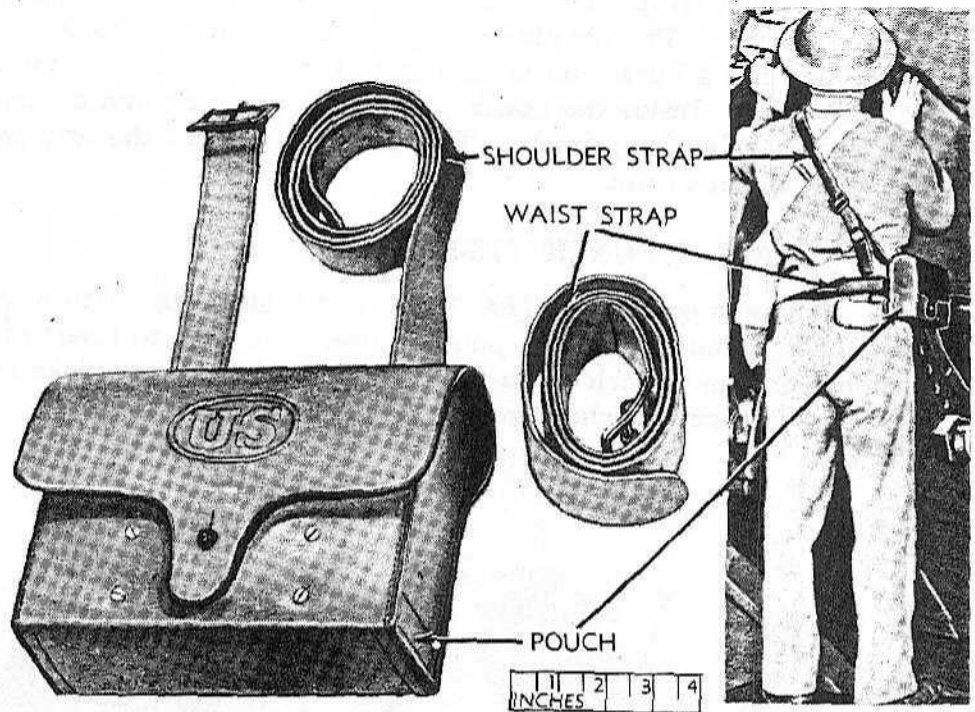

RA PD 54099

Figure 78 — Gunner's Pouch (34-P-483-500)

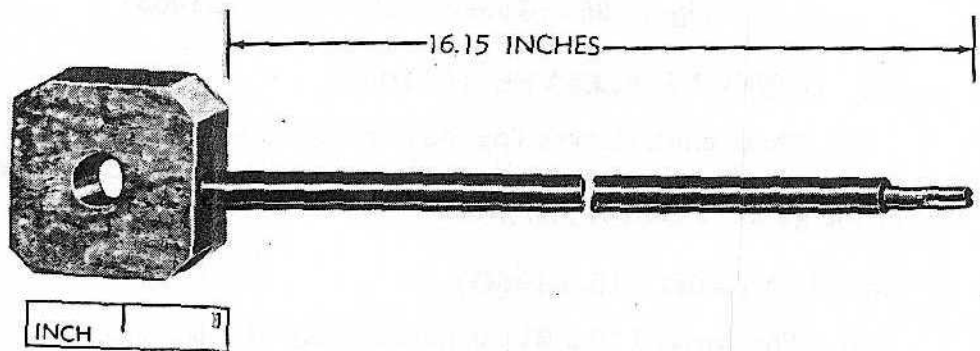

RA PD 54100

Figure 79 — Gunner's Punch (15-5-47T)

*Organizational Spare Parts and Accessories***83. GUNNER'S POUCH (34-P-483-500).**

a. The gunner's pouch (fig. 78) is a leather pouch with a shoulder strap and waist strap. It is used to carry primers and a primer seat cleaning brush. The shoulder strap is secured to the back of the pouch and has a buckle for adjusting its length according to the size of the wearer. Inside the pouch is a leather partition and a wooden block with holes for primers. The pouch is kept in the armament chest when not in use.

84. GUNNER'S PUNCH (15-5-47T).

a. The gunner's punch (fig. 79) is a stiff steel wire with a small steel head on one end. The punch is used as a drift to insert in the primer vent, and punch out a fired primer if the primer sticks in its seat and the firing mechanism fails to eject it.

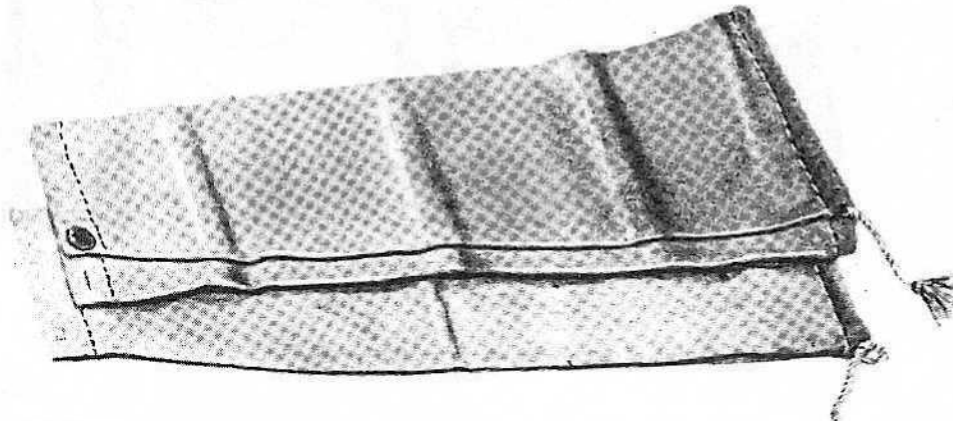

RA PD 54101

Figure 80 — Gunner's Sleeves (24-5-1005)**85. GUNNER'S SLEEVES (C61000).**

a. These cloth sleeves (fig. 80) are designed to fit over the arms of the gunner and extend a little above the elbows for the protection of the gunner's clothes and arms.

86. LANYARD (15-5-196D).

a. The lanyard (fig. 81) is an assembly of sash cord (24 inches), a wooden handle, and a steel hook. The length of the lanyard (overall) is 37 inches. It is hooked to the firing mechanism for firing by hand. The lanyard is pulled with a quick strong pull (not a jerk) from a position as near the rear of the piece as is convenient, and sufficiently to the right of the line of recoil to insure safety.

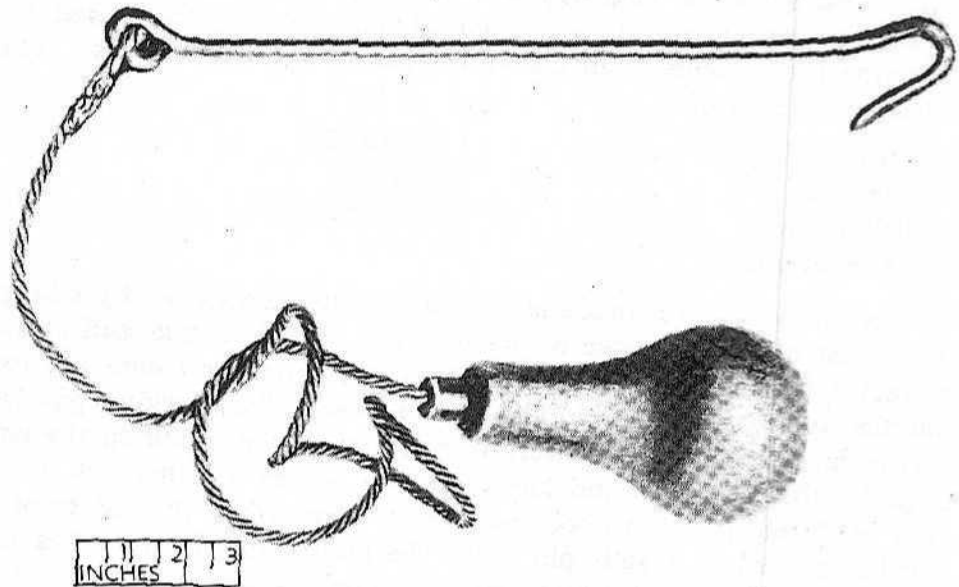

RA PD 54102

Figure 81 - Lanyard (15-5-196D)

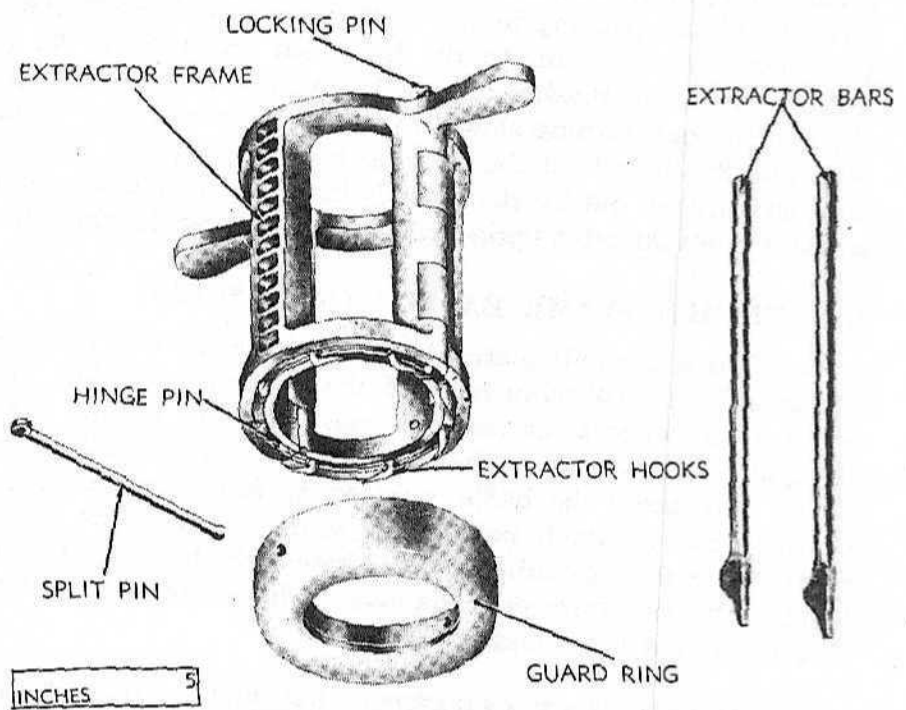

RA PD 54103

Figure 82 - Packing Extractor (15-5-2B)

*Organizational Spare Parts and Accessories***87. PACKING EXTRACTOR (15-5-2B).**

a. This extractor (fig. 82) is a steel cylindrical frame with two handles on one end and eight sharp hooks on the other, used for removing the packing from the recoil piston rod stuffing box. The extractor consists of:

1 Extractor frame	1 Guard ring
1 Hinge pin	1 Split pin
1 Locking pin	2 Extractor bars
8 Extractor hooks	

The extractor frame is made in two halves hinged together by a hinge pin. The extractor hooks or needles are bolted to one end of the extractor frame. On the other end of the extractor frame are two handles for turning and pulling packing out. The locking pin has an eye on one end and is inserted in the extractor frame on the side opposite the hinge pin and locks the two halves together. A guard ring is placed over the hooks to protect them when the extractor is not being used. A split pin holds the guard ring on the extractor. The extractor bars are used to start the packing from its seat.

b. To use the extractor: Start by prying the packing from its seat in the stuffing box with the two extractor bars. Pull out the split pin and remove the guard ring from the extractor hooks. Remove the locking pin and open the extractor. Then close the extractor around the piston rod (with the hooks of the extractor facing in the direction of the packing in the stuffing box) and insert the locking pin. Turn the extractor to the left, with pressure on the packing, until the hooks or needles are firmly engaged in the packing. Draw the packing out, turning slowly to the left. In case of a stuffing box with interior threads, if the packing is tight it should be unscrewed, and not stripped out by the threads in the stuffing box. Unless unscrewed it would catch upon and be damaged by the threads.

88. PRIMER FLAME BAFFLE (63-10-20T3).

a. This is a small plate (fig. 83) which fits over the vent hole in back of the mushroom head of the obturator spindle. It is used, when firing primers for test purposes, to avoid fouling the bore of the gun. It is stored in the same chest with the subcaliber equipment. To install the baffle, proceed as follows: Remove dummy pressure plugs, attach baffle, and screw on with the two holding screws from the subcaliber chest to retain the baffle on the obturator head. Fire the primers. Remove baffle plate and replace plugs. Clean the vent holes and primer seat.

89. PRIMER SEAT CLEANING REAMER (15-5-47AA).

a. This reamer (fig. 84) is used to ream out the primer seat and to keep it free of powder residue. Care must be exercised not to

Organizational Spare Parts and Accessories

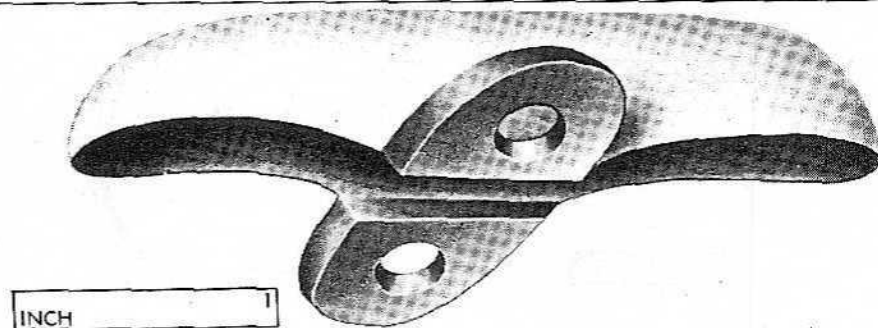
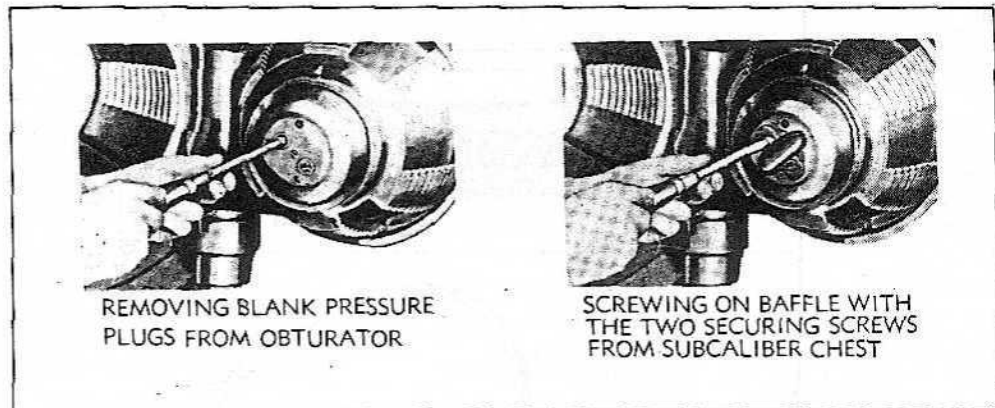

RA PD 54104

Figure 83 — Primer Flame Baffle (63-10-20T3) (Installation Shown on 6-in. Gun M1903A2)

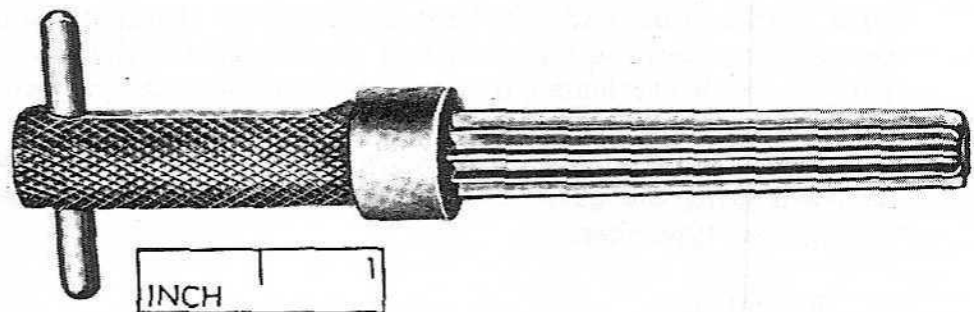

RA PD 54105

Figure 84 — Primer Seat Cleaning Reamer (15-5-47AA)

exert pressure enough to damage either the reamer or obturator spindle. It is kept in the firing mechanism box.

90. PROPELLING CHARGE GAGE (6-INCH GUN, M1900, 03, 05) (24-4-3249A1).

- a. This is a circular gage (fig. 85) shaped to form a true circle, with an inside diameter equal to the correct diameter of the propelling charge. The gage is slipped over the propelling charge from one end to the other, to determine the maximum allowable diameter

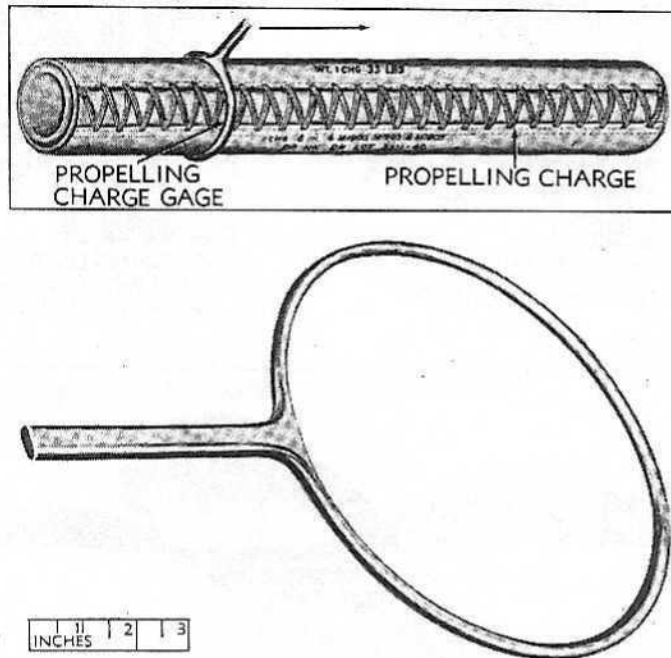

RA PD 54106

**Figure 85 — Propelling Charge Gage (6-inch Gun M1900, 03, 05)
(24-4-3249A1)**

of the charge to be used. If the diameter of the charge is too great, the space between the top surface of the charge and the top of the chamber wall is eliminated, thereby interfering with the projection of the flame from the igniter to the front of the powder charge. This condition sometimes builds up excessive pressures which prove dangerous when firing the gun. This gage, however, is not used on the "core-igniter" type charge.

91. RAMMER.

a. The rammer is made up of the rammer head and rammer staff which are described below.

(1) **RAMMER HEAD (64-1-35).** The rammer head (fig. 86) is cone-shaped (aluminum) and constructed to be assembled to the rammer staff 64-1-39. When so assembled, it is used to ram the projectile firmly into its seat in the bore of the gun. The rammer head is equipped with a soft bronze ring around the front end. A hole in the front end of the rammer head is provided to clear the fuzed end of the projectile when the rammer head is inserted from the muzzle end of the gun and is used to remove a lightly stuck projectile from the gun without firing. This hole also clears the center of the base of the projectile when ramming, thereby eliminating pressure on the

Organizational Spare Parts and Accessories

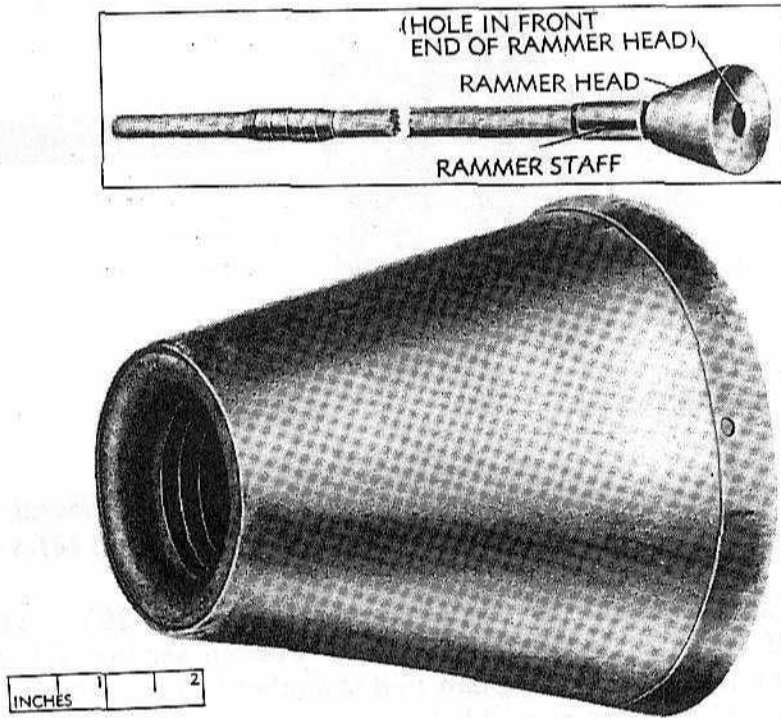

RA PD 54107

Figure 86 — Rammer Head (64-1-35)

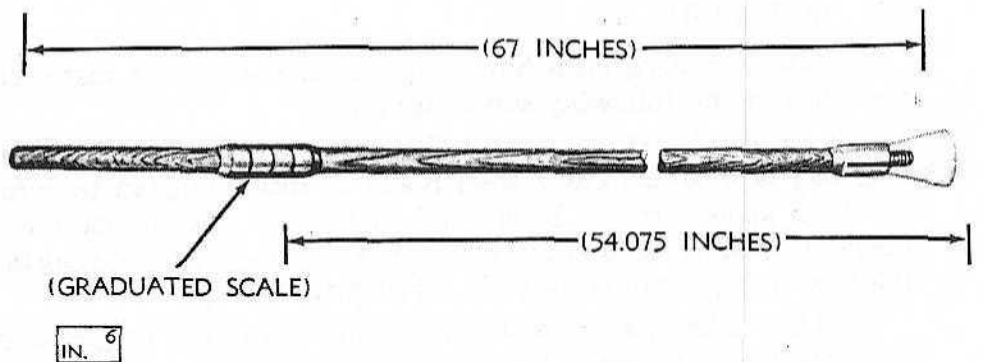

RA PD 54108

Figure 87 — Rammer Staff (6-inch Gun) (64-1-39)

base-detonating fuze (which is in the center of the base directly under the base cover), if one is used.

CAUTION: *Extreme care must be taken when the rammer is used to remove a live projectile. Sometimes the unloading of a projectile by the rammer is prohibited and is removed only by firing.*

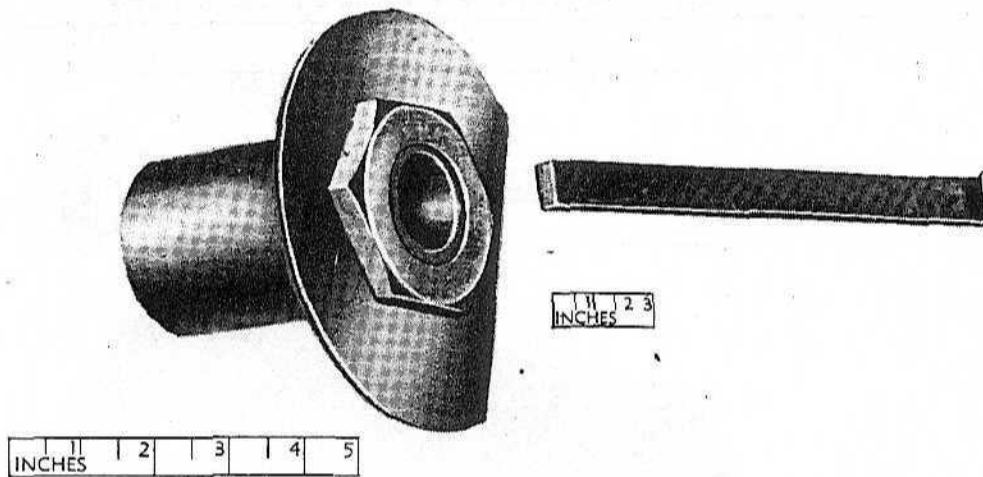

RA PD 54109

RA PD 54110

**Figure 88 — Bore Scraper
(6-inch Gun) (64-1-27)**

**Figure 89 — Metal Scraper
(14-inch) (41-S-772)**

(2) **RAMMER STAFF (6-INCH GUN) (64-1-39).** The rammer staff (fig. 87) is composed of one wooden section, 67 inches long. One end of the staff is plain, and the other is fitted with a coupling by which the staff is assembled to the rammer head. The staff is fitted with a graduated scale for gaging the proper distance a projectile must be rammed into the gun. The scale is set on the staff at 54.075 inches from the front end of rammer head for armor-piercing projectile with broad band (for 6-in. Gun M1900). Relocate scale if any other projectile is used.

92. SCRAPERS.

a. Two scrapers, each having a special use on this materiel, are described in the following subparagraphs:

(1) **BORE SCRAPER (6-INCH GUN) (64-1-27).** The bore scraper (fig. 88) is a semicircular steel blade or disk designed to screw to the bore sponge staff. It is used to remove rust-preventive compound and other substances which have hardened on the surface of the bore and require more than a brush to dislodge.

NOTE: *The scraper should not be used to scrape copper deposits from the bore. Decoppering the bore is prohibited.*

(2) **METAL SCRAPER (14-IN.) (41-S-772).** The metal scraper (fig. 89) is a steel bar with an angular end. Both ends are sharpened to form scrapers which are used in cleaning and painting operations.

93. SPONGE PROP (41-P-2835-100).

a. The sponge prop (fig. 90) is used as a rest or prop for the bore sponge and staff and the rammer head and rammer staff. The head end of the sponge and staff and the rammer to rest upon the

Organizational Spare Parts and Accessories

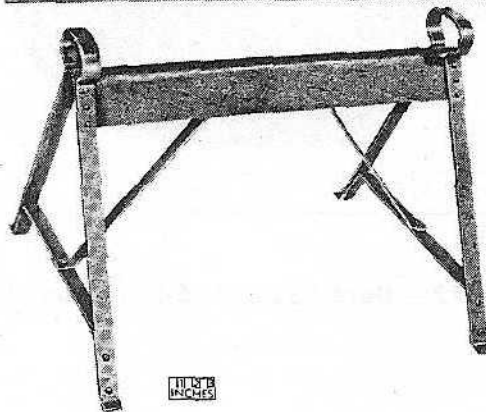
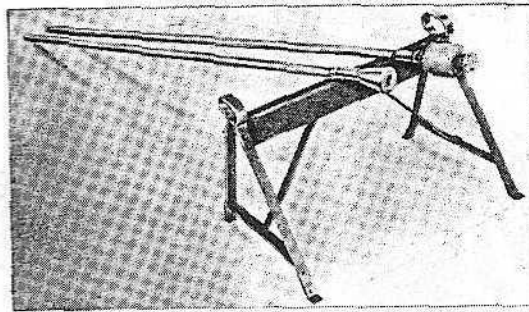

1 1/2 INCHES

RA PD 54111

Figure 90 — Sponge Prop (41-P-2835-100)

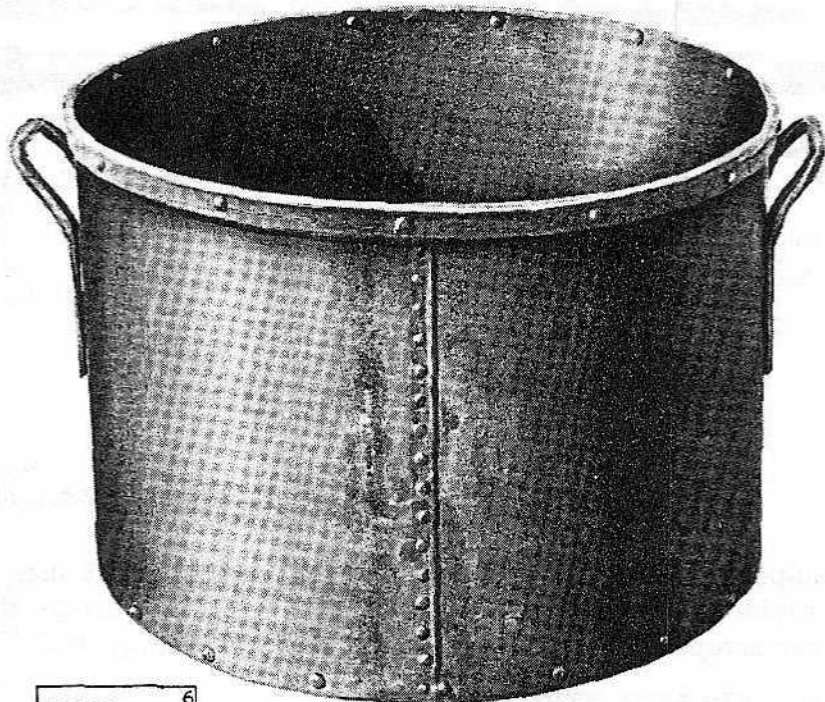

INCHES 6

RA PD 54112

Figure 91 — Sponge Tub (64-1-25A)

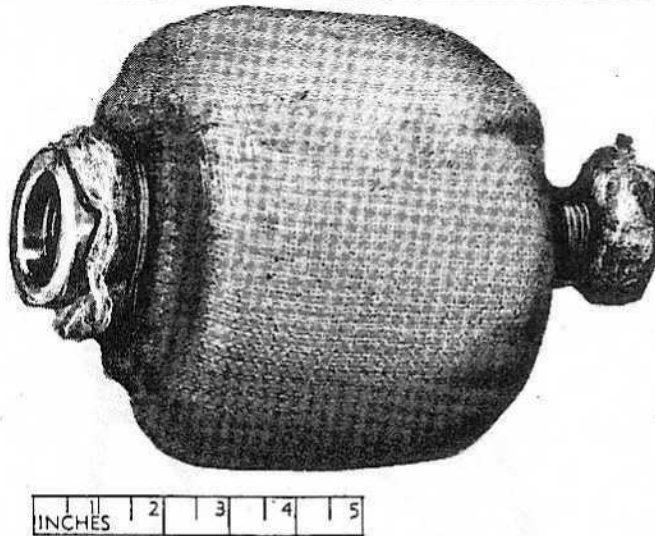

RA PD 54113

Figure 92 - Bore Sponge (6-inch Gun) (64-1-11)

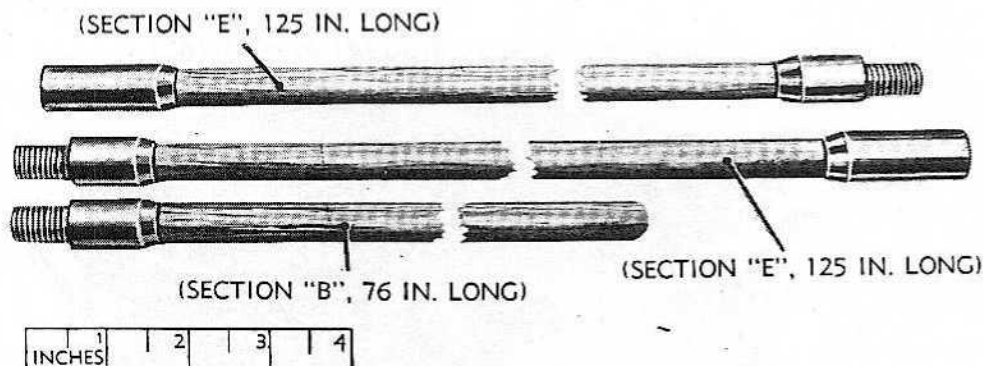

RA PD 54114

Figure 93 - Bore Sponge Staff (6-inch Gun) (64-1-11)

support to keep them clean and ready for immediate use. This also provides easy accessibility for interchanging the sponge, slush brush, bore scraper, or cleaning brush on the bore sponge staff.

94. SPONGE TUB (42-T-13485).

a. The sponge tub (fig. 91) is used to rejuvenate the sponges. The steel tub is filled with sponging solution in which the sponges are allowed to soak before swabbing the bore or chamber.

Organizational Spare Parts and Accessories

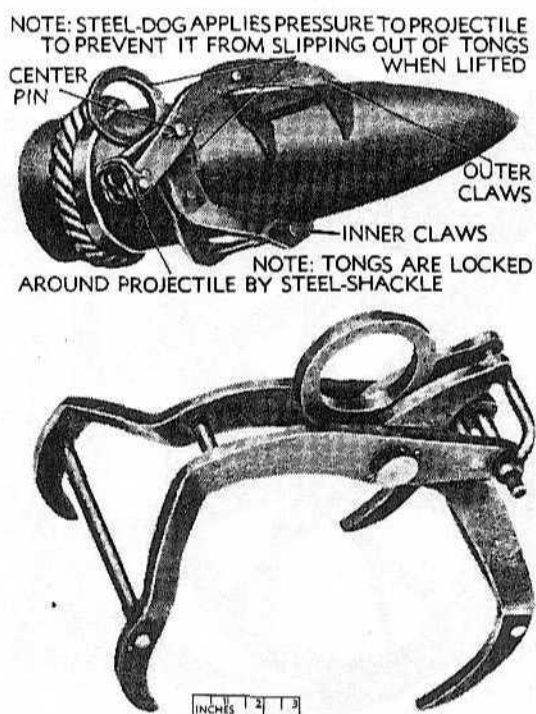

RA PD 54115

Figure 94 — Shot Tongs, M1904 (6-inch Gun) (15-9-24)

95. SPONGES AND STAFF.

a. The special sponges for cleaning the bore and chamber are described below. The sponges used for common cleaning purposes on the materiel are shown under "Supplies."

(1) BORE SPONGE (6-INCH GUN) (64-1-11) (fig. 92). This is a cylindrical, padded form which, when wrapped with burlap and screwed to the end of the staff, is used to clean and dry the bore of the gun.

(2) BORE SPONGE STAFF (6-INCH GUN) (64-1-11). The bore sponge staff (fig. 93) is an assembly composed of one section "B" (76 in. long) and two sections "E" (each 125 in. long). The sections "E," which are fitted with a male coupling at one end and a female coupling at the other, are coupled together and the bore sponge is screwed on one end. The section "B" is plain on one end and has a male coupling on the other for coupling to the section "E" forming the end of the assembled staff. These three sections couple together to form a handle or staff for either the bore sponge, the bore scraper, the slush brush, or the wire-cleaning brush.

(3) CHAMBER SPONGE. There is no special chamber sponge provided. The bore sponge may be used to sponge the chamber, using section "B" (short section) of bore sponge staff.

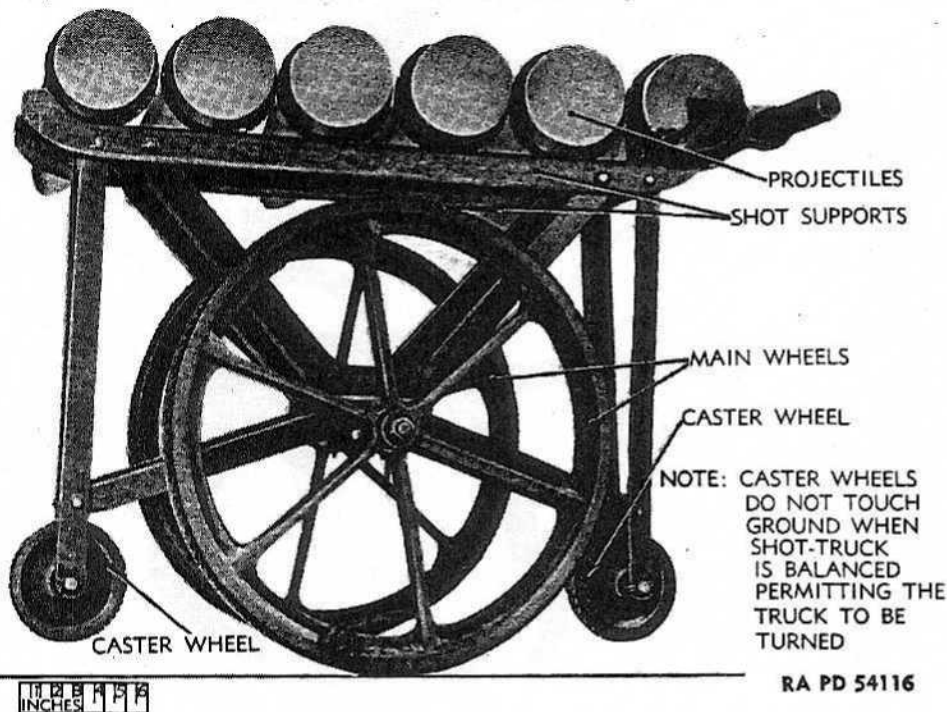

Figure 95 — Shot Truck (Type 6A) (15-9EA-1)

96. SHOT TONGS, M1904 (6-INCH GUN) (15-9-24).

a. These tongs (fig. 94) are a pair of steel claws designed to close around a projectile and used to handle projectiles at the emplacement. The shot tongs consist of a pair of outer and a pair of inner claws which encircle and are fastened together with a center pin, forming hooks that encircle and grip the projectile. When closed around the projectile the upper ends of both pair of claws are locked in place with a shackle and pin.

97. SHOT TRUCK (TYPE 6A) (15-9EA-1).

a. The shot truck (fig. 95) is a steel cart, with four wheels, used to move and haul projectiles and keep them convenient to the breech of the gun for firing. The shot supports of the truck run the length of the truck and curve upward at their ends to provide stops for the projectiles, and attachment for the handle. The truck is supported by four rope-tired wheels (one large main wheel on each side of the truck and one small castor wheel at each end of the truck). The frame of the truck is balanced on the axle of the large main wheels so that when the truck is level the two castor wheels do not touch the ground permitting the truck to be turned (as the castor wheels are fixed and not swiveled). The truck may be tilted to either end to rest upon either castor wheel thereby keeping projectiles

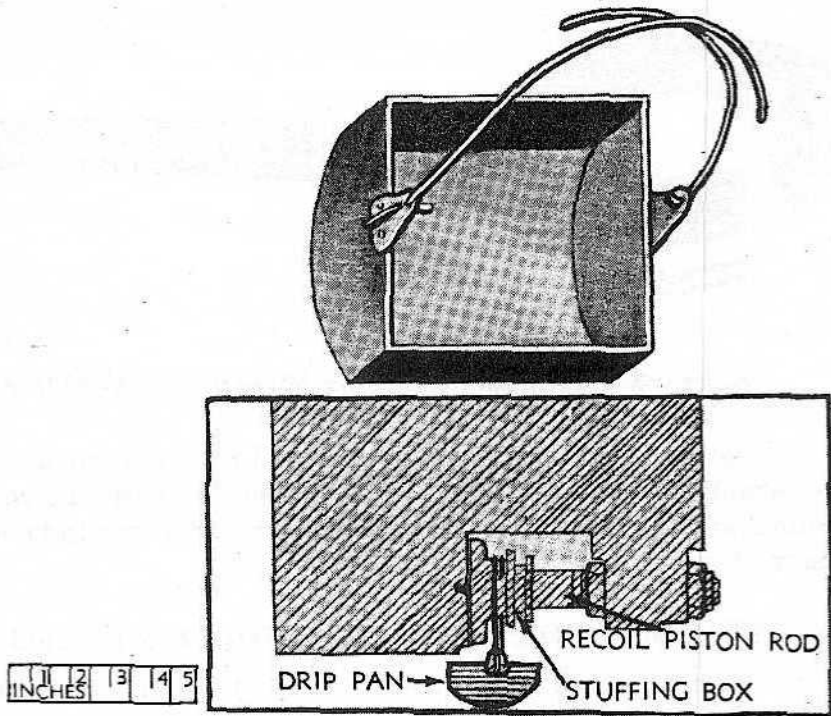

RA PD 54117

Figure 96 – Stuffing Box Drip Pan (Model A) (15-3-2)

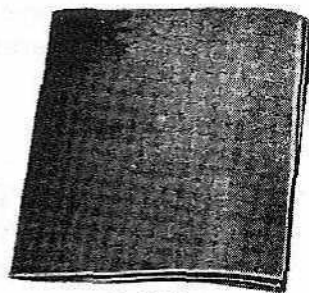

CLOTH -
42-C-20397



NATURAL SPONGE
(15-5-47AX)

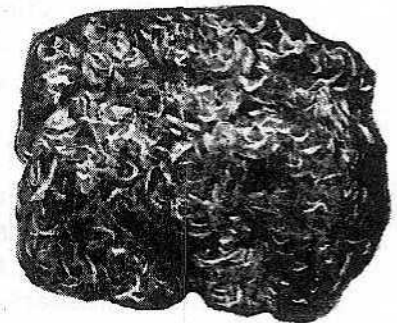

COTTON WASTE
(15-5-47AZ)

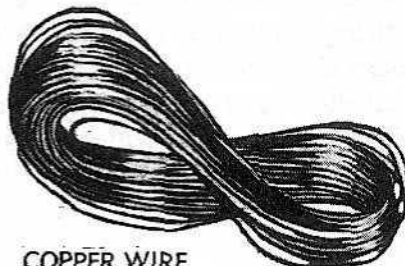

COPPER WIRE
(0.064 IN.)
(15-5-47BB)



TWINE
(15-5-47AY)

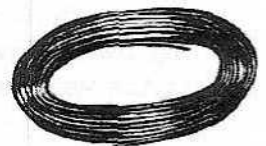

COPPER WIRE
(0.040 IN.)
(15-5-47BA)

RA PD 102097

Figure 97 – Supplies

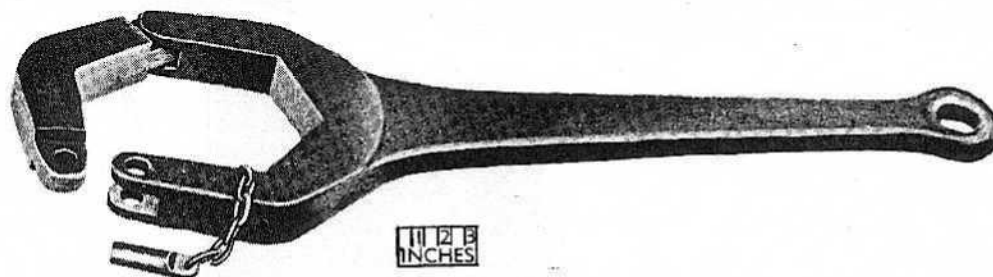

RA PD 54119

Figure 98 — Cylinder Head Box Wrench (41-W-3336-630)

rolled together at one end as they are used from the truck. A wooden bar handle permits the truck to be maneuvered by one man. Projectiles are placed across the truck on the shot supports which accommodate six 6-inch projectiles.

98. STUFFING BOX DRIP PAN (MODEL A) (15-3-2).

a. This is a small metal trough (fig. 96) with a bail, used to hang on the recoil cylinder follower to catch any dripping oil that might escape from the stuffing box when the gun and carriage are not in use.

99. SUPPLIES.

a. Common supplies such as abrasive cloth, natural sponges, twine, cotton waste, and copper wire used in cleaning operations, wrapping bore sponges, etc., are illustrated on figure 97.

100. WRENCHES.

a. One wrench has a special use and is described below. Those used for common general purposes on the materiel are shown under "Common Tools" (figs. 68 and 69). Always use the proper wrench to prevent the mutilation of parts.

(1) **CYLINDER HEAD BOX WRENCH (41-W-3336-630).** This is a single head box wrench (fig. 98) which may be opened up for use on the recoil cylinder head. The locking bar (the front part of the hexagonal end of the wrench) opens so that the wrench can be placed around the hexagonal end of the cylinder head, after which the locking bar is closed and locked in place by a steel pin which is fastened to the wrench with a small chain.

CHAPTER 6 – SUBCALIBER EQUIPMENT

101. PURPOSE.

a. Subcaliber equipment is used for training purposes only, to provide practice in laying and firing the 6-inch gun. The use of smaller bore ammunition prevents wear on the regular piece during practice and is less costly. Although the handling and loading, as well as the range obtained, differ from those of the regular piece, the elevating, traversing, sighting, etc., are adequate for instructional purposes.

b. The subcaliber equipment consists of the 1.457-inch subcaliber gun complete with adapters and accessories.

102. GENERAL.

a. The 1.457-inch subcaliber gun, adapted to 6-inch Gun M1900, (fig. 99) consists of a steel tube to which is attached the front adapter and rear adapter, with related parts, to secure the tube concentrically in the chamber of the 6-inch gun.

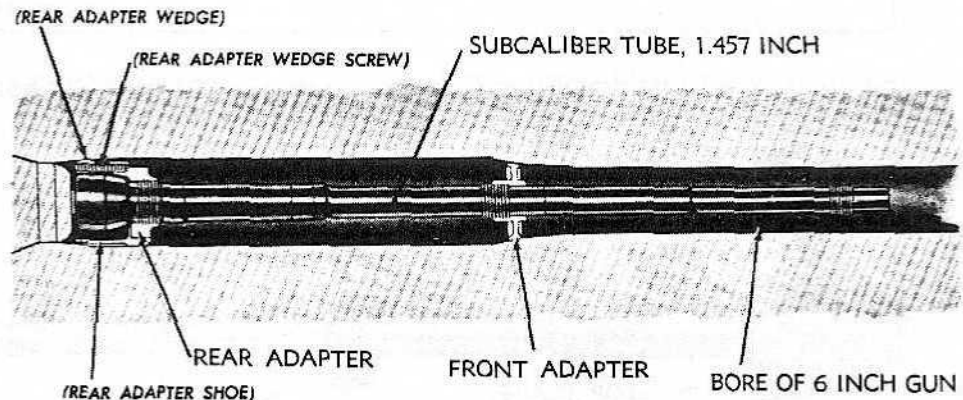

RA PD 54131

Figure 99 – Gun, Subcaliber, 1.457-inch (Adapted to 6-inch Gun M1900)

b. The subcaliber designation and type are stamped on the upper rear face of the tube. The manufacturer and date are stamped on the upper front face of the tube. Weight of tube assembly, number, and inspector's initials are stamped on the lower front face of the tube. The designation of the 6-inch gun is stamped on the bottom of the front adapter, the rear adapter, and related parts.

c. The firing mechanism consists of the firing mechanism of the 6-inch gun, adapted for use with a 1.457-inch shell incorporating an ignition-type primer, by addition of plate fastened to the face of the obturator spindle and containing a vent designed to converge the blast from the 6-inch primer against the subcaliber primer.

Subcaliber Equipment

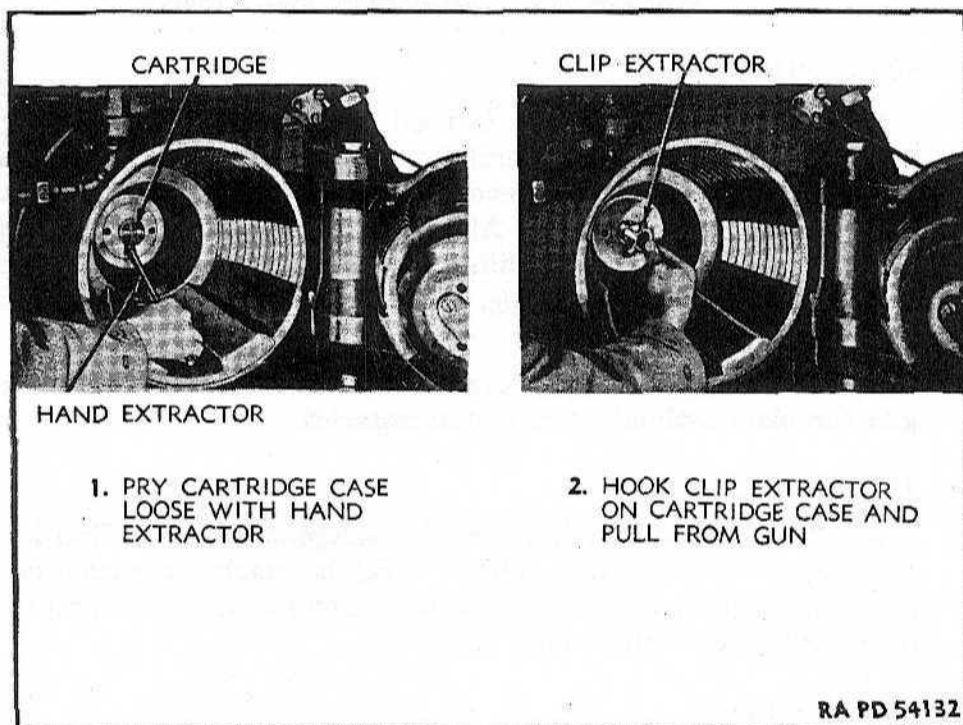

Figure 100 — Cartridge Case Removal (6-in. Gun M1903A2 Shown)

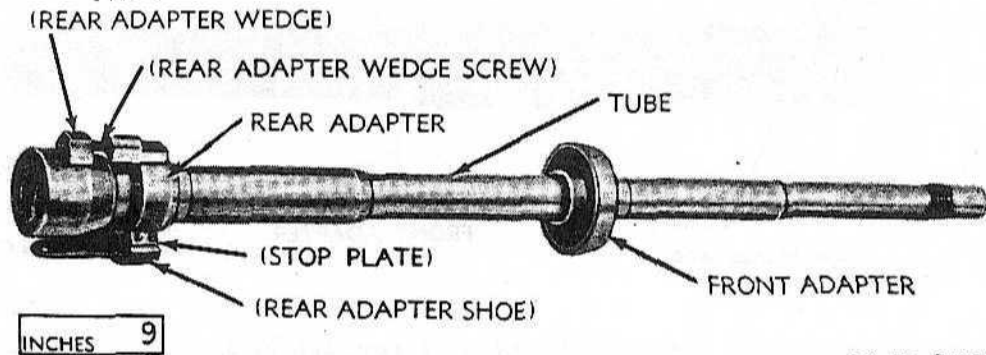

Figure 101 — Tube Group

103. OPERATION.

a. To Load the Gun.

(1) Thrust a round into the subcaliber chamber, pushing it forward as nearly as practicable to seal against the breech face of the tube.

(2) Close the breech of the 6-inch gun in the usual manner.

(3) Insert a standard primer (6-inch gun) in the firing mechanism of the 6-inch gun.

b. To fire the gun: follow usual method of firing 6-inch gun.

Subcaliber Equipment

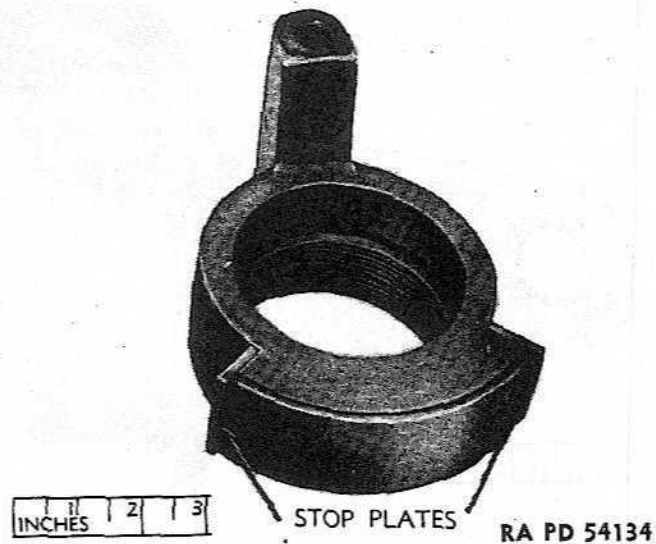

Figure 102 – Rear Adapter (63-7-21B) W/Stop Plates (63-7-21A)

c. To remove the fired case.

- (1) Open the breech of the 6-inch gun in the usual manner.
- (2) Place the lip of the hand extractor forward of the rim of the case (fig. 100) in the rectangular concave recess on the breech face of the subcaliber tube. Pry the case free. Remove the hand extractor and hook the clip extractor on the case, forward of the rim. Pull the case out of the subcaliber tube.

104. DETAILED DESCRIPTION.

a. **Tube Group.** The tube group (fig. 101) consists of the tube, rear adapter with adapter shoe, adapter wedge, adapter wedge screw, stop plates, stop plate screws, and front adapter.

b. The tube (fig. 101) has threads near the front end which are not used in this assembly. Just forward of the breech hoop, the tube is threaded to receive the rear adapter. At about the middle, the tube is threaded to receive the front adapter. The breech end of the tube has a rectangular concave recess at the twelve o'clock position for hand extractor. Holes drilled at the three o'clock and nine o'clock positions receive lugs of adjusting wrench.

c. **Rear Adapter and Related Parts.**

- (1) The rear adapter (fig. 102) consists of a cast bronze hub which is axially bored and threaded (at forward end) to screw on the tube just forward of the breech hoop. A rearward projecting lug, at the top of the adapter, is drilled and tapped left hand to receive the adapter wedge screw; the lower segment of the adapter is machined to seat into the adapter shoe and the ends of the segment are drilled and tapped to receive the stop plate screws. A radial oil hole is provided in the hub.

Subcaliber Equipment

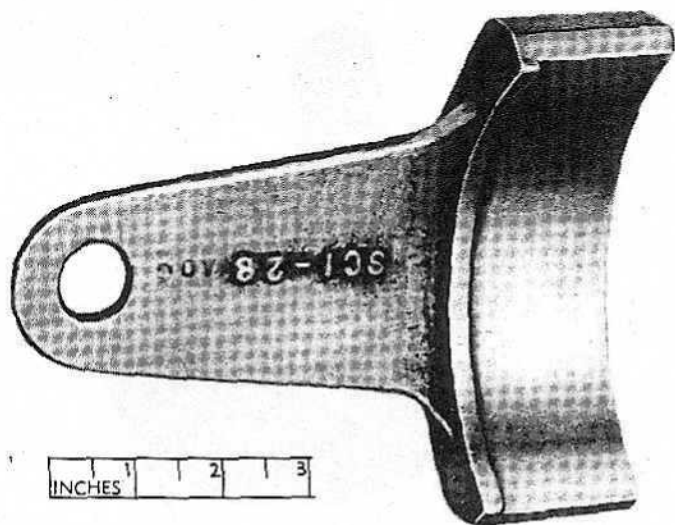

RA PD 54135

Figure 103 — Rear Adapter Shoe (63-7-21F1)

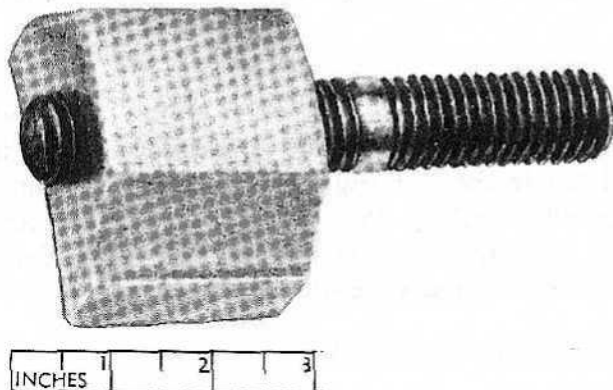

RA PD 54136

Figure 104 — Rear Adapter Wedge (63-7-21D2) and Rear Adapter Wedge Screw (63-7-21H)

(2) The two stop plates (fig. 102) are rectangular bronze plates with two countersunk holes for the stop plate screws, which attach the plates to the ends of the rear adapter segment to hold the rear adapter shoe in place.

(3) Stop plate screws are standard 0.25 x 0.625 flat-head brass screws.

(4) The rear adapter shoe (fig. 103) consists of a bronze casting which supports the rear adapter and aligns the tube in the bore of the 6-inch gun. The front portion of the shoe is curved on the inside to fit the bottom of the rear adapter and on the outside to fit the chamber of the 6-inch gun. An integral shoulder contacts the rear face of the rear adapter and prevents forward movement of the shoe. A rearward extending arm is provided with a drilled hole, near the rear end, to aid in inserting and removing the shoe.

Subcaliber Equipment

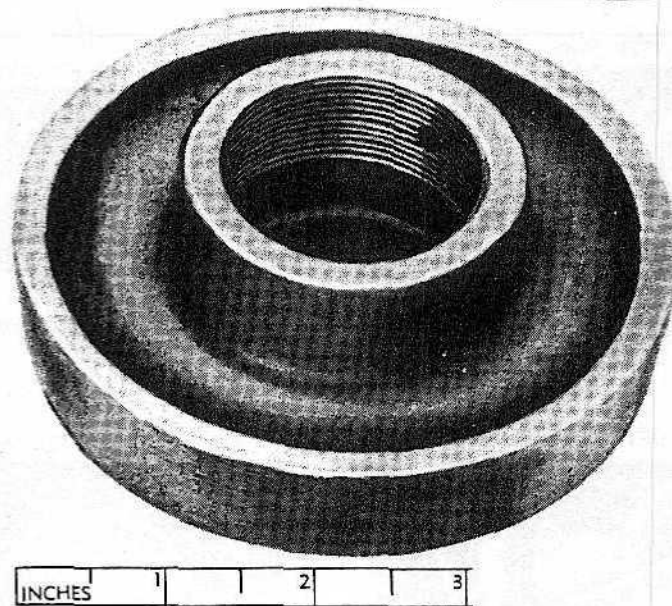

RA PD 54137

Figure 105 – Front Adapter (63-7-21C2)

(5) The rear adapter wedge (fig. 104) is a rectangular bronze block drilled and tapped longitudinally with a right-hand thread to receive rear adapter wedge screw; the bottom is curved to fit the top of the breech hoop; the top is curved and sloped rearward to fit the chamber of the 6-inch gun. The wedge secures and prevents any movement of the subcaliber assembly in the chamber of the 6-inch gun.

(6) The rear adapter wedge screw (fig. 104) is a machine steel screw with left-hand threads on forward end and right-hand threads on rear end. A slot is provided in rear end of the screw. The screw holds the rear adapter wedge and draws it into position.

d. **Front Adapter.** The front adapter (fig. 105) is the front support of the tube. It consists of a hub with a solid flange and an external rim with a conical surface which centers the subcaliber tube on the centering slope in the chamber of the 6-inch gun and prevents the subcaliber gun moving forward out of proper position. The hub is bored axially and the rear section is threaded to screw on the middle part of the tube. A drilled hole in the rim is provided for insertion of the dismounting pin provided to facilitate rotation of the adapter on the tube. A radial hole in the hub provides for oil lubrication of the threads.

e. The firing mechanism on the 6-inch gun is used with the following change: The blank pressure plugs are removed and replaced by an obturator spindle plate, which contains a central aperture to concentrate the hot primer gases against the ignition primer of the subcaliber cartridge.

Subcaliber Equipment

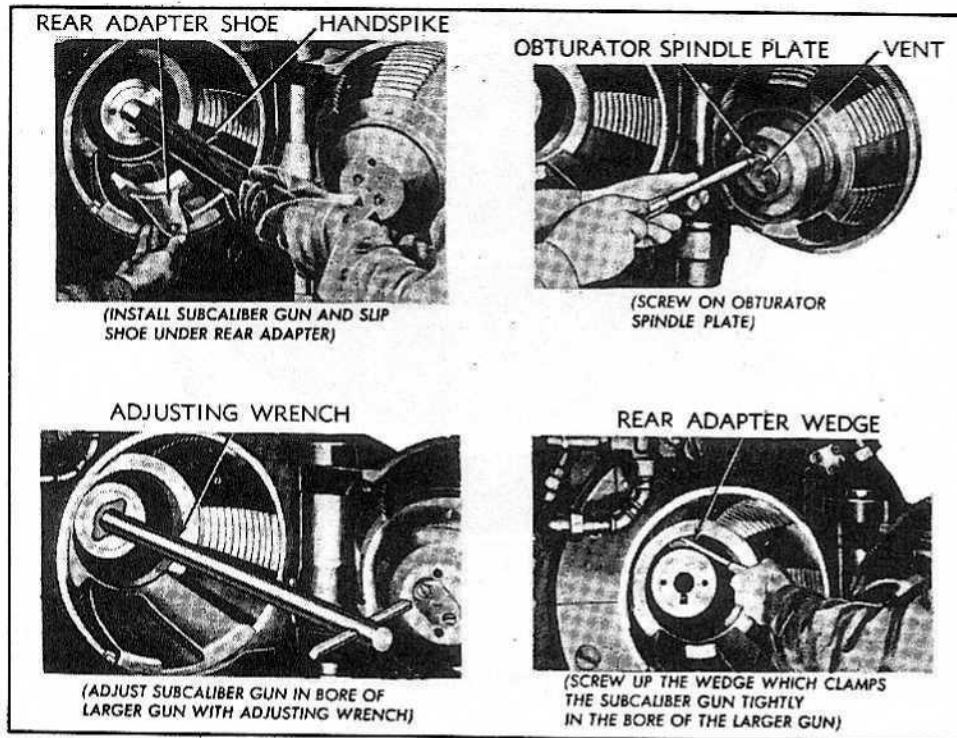

RA PD 54138

Figure 106 – Subcaliber Gun Installation

105. ASSEMBLY OF TUBE GROUP.

- a. Place the rear adapter (threaded section forward) over forward end of tube, move to threaded section just forward of breech hoop, and screw on tube.
- b. Start the rear adapter wedge screw into the rear adapter wedge (with slotted end of screw to largest part of wedge). Start opposite end of screw into rear adapter. Tighten the screw enough to hold parts together.
- c. Fasten the stop plates on the rear adapter with the stop plate screws.
- d. Place the front adapter (threaded section to the rear), over forward end of the tube, move to the threaded section at the middle of the tube, and screw on the tube.

106. DISASSEMBLY OF TUBE GROUP.

- a. Unscrew front adapter from tube and remove over forward end of tube.
- b. Unscrew the rear adapter wedge screw from the rear adapter and also from the rear adapter wedge.

Subcaliber Equipment

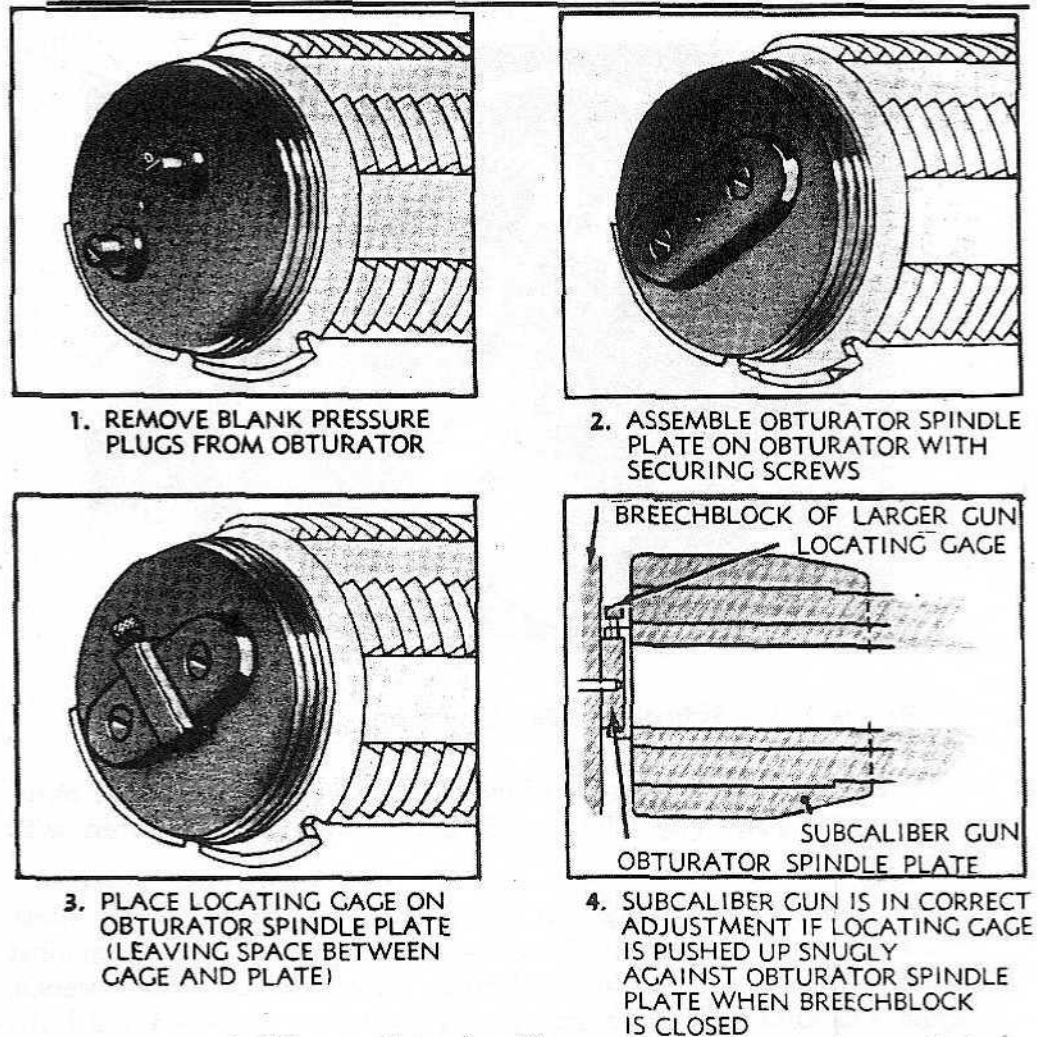

Figure 107 - Adjustment of Subcaliber Gun RA PD 54139

c. Unscrew the stop plate screws from the rear adapter and remove the stop plates.

d. Unscrew rear adapter from tube and remove over forward end of tube.

107. INSTALLATION OF SUBCALIBER GUN.

a. Be sure chamber and subcaliber assembly are perfectly clean.

b. Insert the assembled tube group, into the 6-inch gun, seating the front adapter in the conical centering slope, with the rear adapter wedge uppermost. Before the front adapter is fully seated, insert screwdriver through hole in rear adapter wedge and turn the wedge screw counterclockwise to move wedge close to rear adapter.

c. Insert the rear adapter shoe (fig. 106) in place under the lower segment of rear adapter. Be sure shoulder of shoe contacts rear face of segments.

Subcaliber Equipment

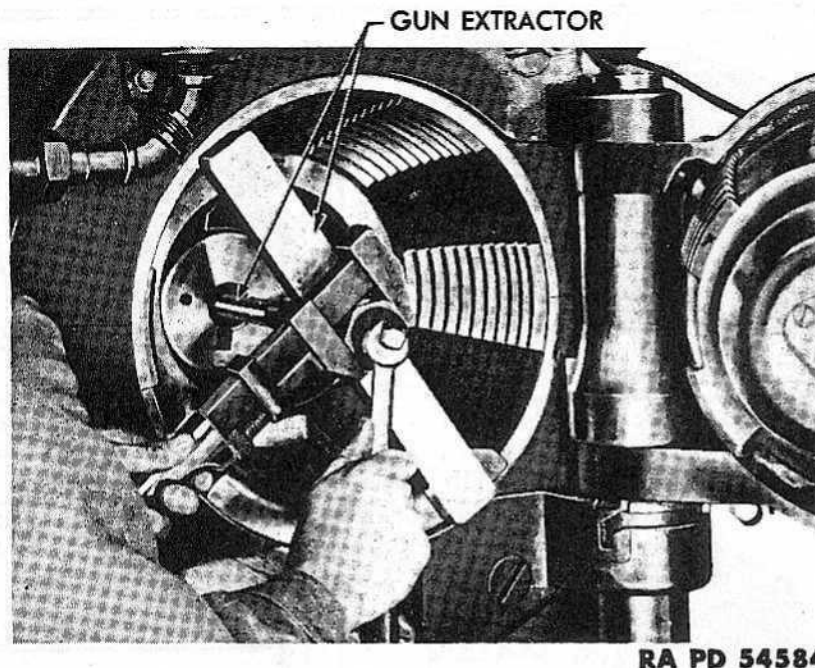

RA PD 54584

Figure 108 — Subcaliber Gun Removal, Using Gun Extractor

d. Remove blank pressure plugs from the obturator. Place obturator spindle plate (fig. 106) on face of obturator and fasten with securing screws.

e. Fasten locating gage on the obturator spindle plate. Close breech of the 6-inch gun. Locating gage should fit snugly against the breech face of the subcaliber gun. Using the adjusting wrench, adjust subcaliber tube by screwing forward or rearward until the gage fits snugly against breech face.

f. When subcaliber tube is in correct position, as determined by the locating gage, tighten rear adapter wedge by turning rear adapter wedge screw clockwise until wedge is firmly seated against the chamber of the 6-inch gun. **NOTE:** *After tightening try adjustment with the locating gage. If adjustment has changed, loosen screws and re-adjust (see "Adjustment," par. 108).*

108. ADJUSTMENT.

a. The subcaliber tube is in correct adjustment (fig. 107) when the locating gage is pushed just against the obturator spindle plate when the breech of the 6-inch gun is closed. To adjust, slip locating gage over obturator spindle plate, leaving a space between gage and spindle plate. Close breech gently. If resistance is encountered between breech of the 6-inch gun and the subcaliber tube, the tube is too far to the rear. Open the breech, loosen adapter wedge, and turn gun clockwise with adjusting wrench. If it has not been pushed

Subcaliber Equipment

all the way back, measure the distance between plate and gage, loosen adapter wedge, and unscrew tube one turn for each 0.1 inch. Continue to try in this manner until gage is pushed just against spindle plate when closing the breech. Having adjusted subcaliber gun until locating gage is pushed against spindle plate by closing breech, tighten the wedge screw with the screwdriver, setting the wedge firmly back against rear slope of chamber to prevent subcaliber gun from turning. The gun is then ready to fire.

109. REMOVAL OF SUBCALIBER GUN.

a. Loosen the rear adapter wedge by turning the rear adapter wedge screw counterclockwise until the wedge is free. Remove the rear adapter shoe. Remove tube assembly from chamber of the 6-inch gun. Disassemble tube group as described in paragraph 106.

b. Remove obturator spindle plate from the obturator of the 6-inch gun. Replace blank pressure plugs.

NOTE: If front adapter sticks in chamber of 6-inch gun and cannot be worked loose with handspike, use gun extractor (fig. 108).

110. CARE AND PRESERVATION.

a. The subcaliber gun is subject to the same type of wear as the major item. It is therefore maintained in the same manner (par. 35).

b. When the subcaliber gun is not to be used for a considerable time, the bore and the bright, unpainted surfaces should be cleaned with dry-cleaning solvent. Coat the bore with rust-preventive compound (heavy) and the exterior unpainted surfaces with rust-preventive compound (thin film).

c. In assembly and disassembling, do not use a steel hammer directly on any part. A copper plate or drift should be interposed, or a rawhide headed hammer used to prevent deforming the part.

d. Daily when no firing is done, wipe the bore clean and renew the oil film. Every 5 days swab with dry-cleaning solvent and wipe thoroughly dry before oiling.

111. LUBRICATION INSTRUCTIONS.

a. Excessive wear can be prevented and the life of the subcaliber gun increased to a marked extent by keeping the materiel clean and properly lubricated. Apply sufficient lubrication but avoid excessive and wasteful practices. Excessive lubrication invites dirt accumulation on the materiel. Parts should be manipulated while the lubricant is being applied so as to distribute the lubricant over the bearing surfaces.

Subcaliber Equipment

Parts Lubricated	Frequency	Method and/or Application	LUBRICATION CHART		Amount	Remarks
			Required Lubricants			
			+32° F to 0° F	Above +32° F		
Bore	Daily	Cleaning sponge	Engine oil SAE 10	SAE 30	Film	Lubricate daily and after firing.
Adapters	Daily	Oiler	Engine oil SAE 10	SAE 30	Film	Clean and lubricate before and after removal from 6-inch gun.

NOTE: At temperatures below 0° F, use preservative lubricating oil (special).

112. INSPECTION.

a. Inspect parts for wear, burs, or other mutilations. See that they are clean and well lubricated. Note condition of bore for copper deposits on the lands and in the grooves and erosion at origin of rifling.

113. LIST OF PARTS.

- ADAPTER, front (63-7-21C2) (1) SCREW, stop plate, Std. 0.25 x 0.625 Flat Head, Brass (63-7-21E) (4)
- ADAPTER, rear (63-7-21B) (1) SHOE, rear adapter (63-7-21F1) (1)
- PLATE, stop (63-7-21A) (2) TUBE, subcaliber (63-10-3) (1)
- SCREW, rear adapter wedge (one spare) (63-7-21H) (2) WEDGE, rear adapter (63-7-21D2) (1)

114. SUBCALIBER ACCESSORIES.

a. General. The accessories for the subcaliber gun include those tools which are essential to the functioning and operation of the subcaliber gun and for its insertion and removal from the larger gun. These accessories should be kept clean and well oiled with preservative lubricating oil (medium) or (special) to prevent rust and deterioration. When not in use they should be stored in their proper chests.

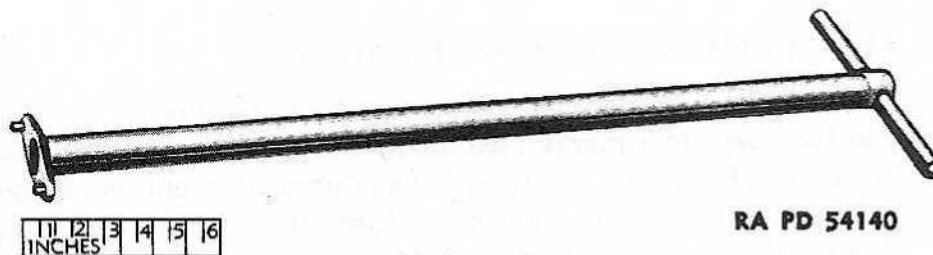

Figure 109 — Adjusting Wrench (63-13-17J1)

Subcaliber Equipment



RA PD 54141

Figure 110 – Cleaning Sponge (63-13-18) (17E2)

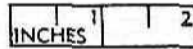
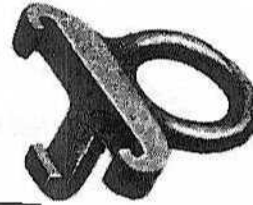

RA PD 54142

Figure 111 – Clip Extractor (63-13-17V)

b. List of subcaliber accessories:

CHEST, storage "B" (63-10-17) (1)	OILER, S., 1/3 pt. (CLGX1A) (1)
CHEST, storage "C" (63-7-24) (1)	PIN, dismounting (63-13-17Q) (1)
CLEANER, vent (63-13-18) (17W) (1)	ROD, sponge, 74.5 in. (63-13- 18) (17CA) (1)
EXTRACTOR, clip (63-13- 17V) (1)	SCREW, securing (63-10-20Q3) (2)
EXTRACTOR, gun complete (63-13-18) (17DA) (1)	SCREWDRIVER, comm., nor- mal duty, 8-in. blade (TGAX1C) (1)
EXTRACTOR, hand (63-13- 17C) (1)	SPONGE, cleaning, 1.8 in. diam. (63-13-18) (17E2) (1)
GAGE, locating (63-13-18) (17G3) (1)	WRENCH, adjusting, short shank (63-13-17JI) (1)
HANDSPIKE (63-13-18) (17PI) 1	

c. Those accessories listed above which are of a special nature or have a special use are described below:

(1) ADJUSTING WRENCH (SHORT SHANK) (63-13-17JI). The adjusting wrench (fig. 109) is used to turn the subcaliber gun in the front adapter, to adjust the gun to the breech. On one end of the wrench are two pins which engage with holes provided in the

Subcaliber Equipment

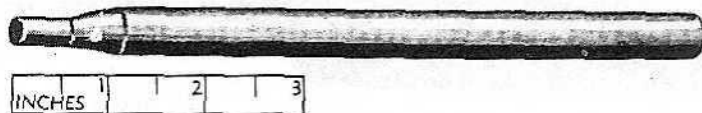

RA PD 54143

Figure 112 – Dismounting Pin (63-13-17Q)

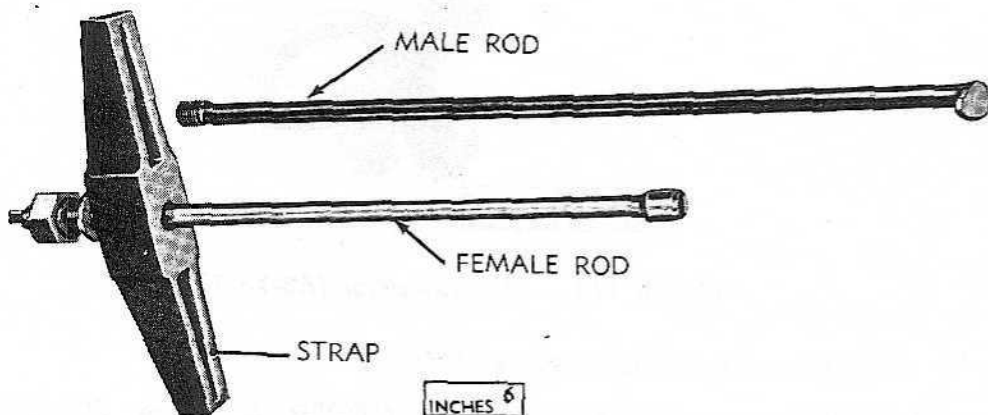

RA PD 54144

Figure 113 – Gun Extractor (63-13-18) (17DA)

breech end of the subcaliber gun. The other end of the tubular shank of the wrench has a T-shaped handle.

(2) **CLEANING SPONGE (63-13-18) (17E2)**. The cleaning sponge (fig. 110) is a carpet covered cylindrical sponge used to clean the bore of the subcaliber gun when assembled to the sponge rod. The sponge, wrapped with burlap is used to oil the bore.

(3) **CLIP EXTRACTOR (63-13-17V)**. The clip extractor (fig. 111) is used to remove sticking cartridge cases after starting the case with the hand extractor. It may also be used when cartridge cases are too hot to handle by hand. The extractor is a bronze eye with three claws which fit over the rim of the cartridge case. A rope may be passed through the extractor eye and wrapped around a lever placed against the face of the breech if necessary.

(4) **DISMOUNTING PIN (63-13-17Q)**. The dismounting pin (fig. 112) fits into a drilled hole in the front adapter to provide leverage for turning it in assembly and disassembly.

(5) **GUN EXTRACTOR (63-13-18) (17DA)**. The gun extractor

Subcaliber Equipment

RA PD 54145

Figure 114 – Hand Extractor (63-13-17C)

RA PD 54146

Figure 115 – Handspike (63-13-18) (17PI)

(fig. 113) is used as a puller for removing the subcaliber gun. Its use is necessary only when the front adapter sticks in the chamber so that it cannot be removed with the handspike. The extractor consists of one male rod and one female rod coupled together, one strap, and one nut and washer. The rod (male and female coupled together) is inserted through the bore of the subcaliber gun until the foot on the front end of the male rod is caught against the muzzle face of the subcaliber gun; then the strap is placed on the rear end of the female rod and pushed up against the breech face of the 6-inch gun. Then, by screwing up the nut against the strap, the subcaliber gun is loosened in the bore. The total length of the extractor coupled together is $110\frac{1}{4}$ inches.

(6) **HAND EXTRACTOR (63-13-17C).** The hand extractor (fig. 114) is for removal of the fired subcaliber cartridge case. It is used as a pry, to pull out the case far enough to use the clip extractor. The hook or lip on the extractor is inserted in the concave recess at the top of the breech end of the subcaliber tube to pry a cartridge case from its seat.

(7) **HANDSPIKE (63-13-18) (17PI).** The handspike (fig. 115) is inserted in the chamber of the subcaliber gun for installing and removing it from the bore of the 6-inch gun. The handspike is a short wooden staff. It has a bronze head, with square shoulder on one end, which is inserted into the chamber; the handle of the handspike serves as a lever to work the subcaliber gun loose from the bore of the larger gun.

(8) **LOCATING GAGE (63-13-18) (17G3).** The locating gage (fig. 116) is a small steel clamp with set screw which is used when inserting the subcaliber gun into the large gun. It is placed on the

Subcaliber Equipment

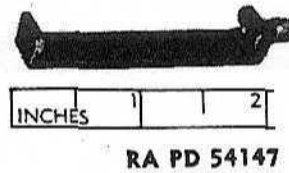

RA PD 54147

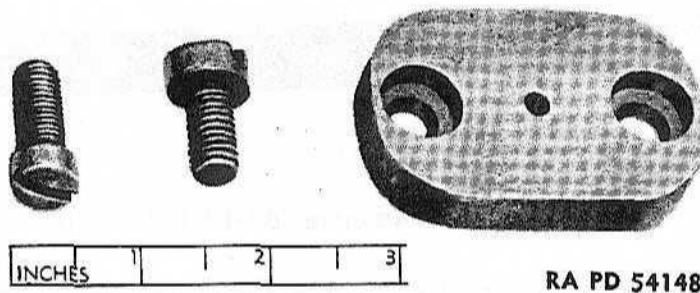
Figure 116 – Locating Gage (63-13-18) (17G3)

RA PD 54148

Figure 117 – Obturator Spindle Plate (63-10-20P3) (W/Securing Screws (63-10-20Q3))

obturator spindle plate so that when the breech is closed, the sub-caliber gun may be properly located in the bore of the 6-inch gun with the proper clearance for the cartridge case between the sub-caliber gun and obturator spindle plate.

(9) **OBTURATOR SPINDLE PLATE (63-10-20P3).** The plate (fig. 117) is screwed to the mushroom head of the obturator spindle of the 6-inch gun with the two securing screws. A vent is provided through the center of the plate for the primer flame to reach the igniter primer in the base of subcaliber cartridge case. This vent is cleaned with the vent cleaner after firing. The obturator spindle plate is a flat hard steel plate with rounded ends. A hole is provided at each end for the securing screws.

(10) **SECURING SCREWS (63-10-20Q3).** These two screws (fig. 117), $\frac{3}{8}$ -16NC x 0.95 are used to secure the obturator spindle plate to obturator mushroom head.

(11) **SPONGE ROD (63-13-18) (17CA).** The sponge rod (fig. 118) is a round wooden staff used with the cleaning sponge to clean the bore of the subcaliber gun. One end is provided with a brass split ferrule with sliding ring for holding the cleaning sponge.

(12) **STORAGE CHEST "B" (63-10-17).** This wooden chest (fig. 119) is used for storing and carrying some of the subcaliber equipment, the rest is kept in storage chest "C." The following subcaliber gun parts and accessories are carried in this chest:

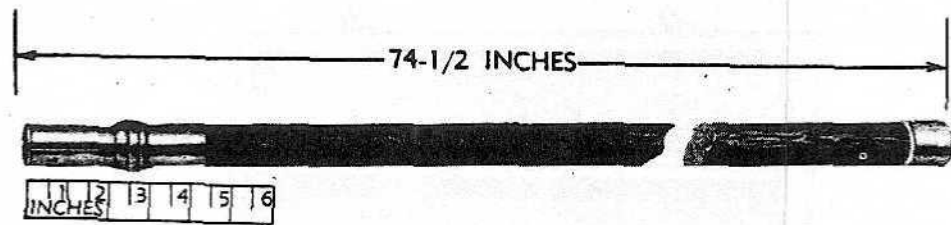

RA PD 54149

Figure 118 – Sponge Rod (63-13-18) (17CA)

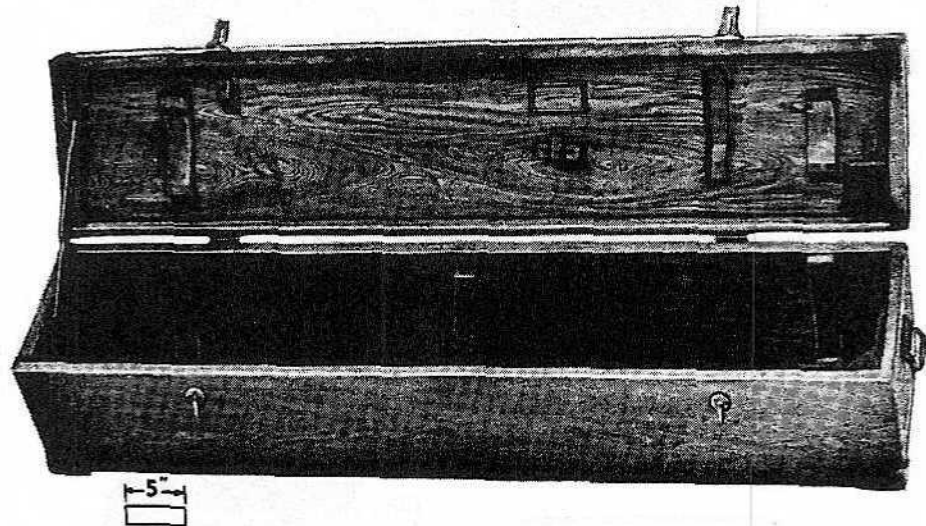

RA PD 54150

Figure 119 – Storage Chest "B" (63-10-17)

CLEANER, vent	OILER
EXTRACTOR, clip	ROD, sponge
EXTRACTOR, gun (complete)	SPONGE, cleaning
EXTRACTOR, hand	TUBE, subcaliber 1.457 in.
GAGE, locating	WRENCH, adjusting
HANDSPIKE	

(13) STORAGE CHEST "C" (63-7-24). This is a rectangular wooden chest (fig. 120) used to store and carry the remainder of the subcaliber equipment. The following is a list of subcaliber gun parts and accessories carried in this chest:

ADAPTER, front	SCREWS, rear adapter wedge (2)
ADAPTER, rear	(one spare)
BAFFLE, primer flame	SCREWS, securing (2)
PIN, dismounting	SHOE, rear adapter
PLATE, obturator spindle	WEDGE, rear adapter
SCREWDRIVER	

Subcaliber Equipment

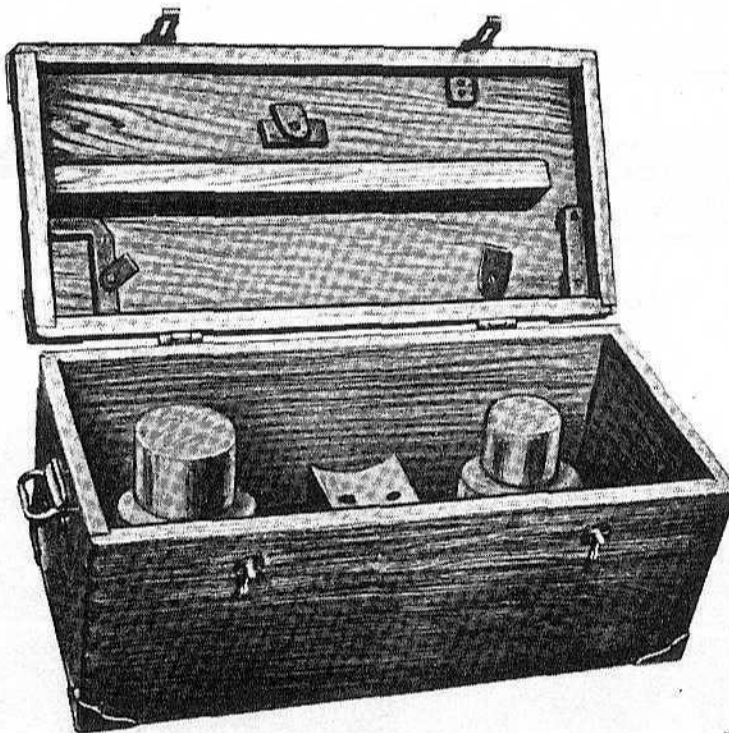

RA PD 54151

Figure 120 — Storage Chest "C" (63-7-24)

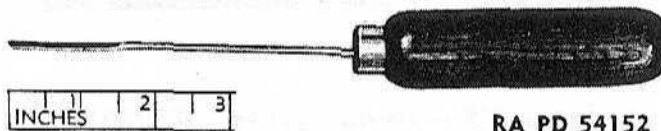

RA PD 54152

Figure 121 — Vent Cleaner (63-13-18) (17W)

NOTE: *The primer flame baffle listed above is not subcaliber equipment, but is carried in the subcaliber storage chest "C" and uses the subcaliber securing screws.*

(14) **VENT CLEANER (63-13-18) (17W).** The vent cleaner (fig. 121) is used to clean the vent in the obturator spindle plate after firing. It has a sharp edge on the end for cleaning the vent.

CHAPTER 7 — PREPARATION OF MATERIEL FOR USE UNDER EXTREME CONDITIONS

115. GENERAL.

a. Because of the different climates in which this materiel may be expected to operate, special instructions are given in this section.

b. Materiel lubricated for a lower temperature range than the one in which it is to be used, should be relubricated with prescribed lubricants.

c. Materiel, previously lubricated for a higher temperature range than that in which it is to be used, should be completely cleaned of all lubricants and relubricated with the lubricants prescribed for use at those temperatures.

116. EXTREMELY HIGH TEMPERATURES.

a. The usual precautions will be taken to see that lubricants specified for use above $+32^{\circ}$ F are used. The lubricant levels in the gear cases and recoil cylinder should be checked.

117. SUBZERO TEMPERATURES.

a. **General.** Preparing a weapon for operation below $+32^{\circ}$ F consists of inspecting and placing weapon in good mechanical condition, cleaning and lubricating with the prescribed lubricants and frequent exercising.

b. **Inspection.** The materiel should be inspected to see that all moving parts operate freely and without binding. The elevating and traversing handwheels should be operated throughout their ranges. *The lubricant level in the gear cases and recoil cylinder should be checked.*

c. **Lubrication of the Materiel.** The materiel should be properly lubricated in accordance with section IV. Before applying cold weather lubricants, the materiel should be thoroughly cleaned and all lubricants removed.

d. **Sighting and Fire Control Instruments.** Sighting and fire control instruments are normally lubricated for operating over a wide range of temperature. They should be exercised frequently during periods of low temperature, to insure their proper functioning. If the instruments do not function properly, the ordnance maintenance personnel should be notified.

Preparation of Materiel for Use Under Extreme Conditions

e. Bore Cleaning.

(1) Cleaning a cold gun tube after firing cannot be accomplished in the normal manner at temperatures below +32° F because the water will freeze in the tube. If cleaning can be done while the tube is hot and hot water is available, soda ash or issue soap solution will be used. Otherwise, it will be necessary to add denatured alcohol, or an emergency substitute (glycerine, or antifreeze compound—ethylene glycol type) to the solution. To 10 parts by volume of cleaning solution (water and soda ash or soap), add the number of parts of one of the antifreezes indicated below:

Temperature ° F	Alcohol	or	Glycerine	or	Antifreeze Compound
20	2		2½		2
10	4		5		3⅓
-15	6½		6½		5
-30	9		10		7¼
-40	16		13		10
	27		16		12

(2) In applying light or special preservative lubricating oil to the bore after cleaning, work the oil in carefully so that it will reach all surfaces of the lands and grooves. When a gun or howitzer which has been exposed to low temperatures is brought into a heated shop, condensation will occur on all metal surfaces. After the gun reaches room temperature, the tube and all other bright parts must be dried and recoated with oil to prevent rusting.

(3) After firing, the tube will be cleaned with bore-cleaning solution on three consecutive days thereafter, or longer if sweating continues, then dried, and oiled.

(4) During periods when the materiel is not fired, the oil film will be renewed daily by swabbing with burlap saturated with oil. Every 5 days, swab with dry-cleaning solvent, dry, and renew the oil film.

f. Bore sponging solutions must be prevented from freezing. Use alcohol in same proportions as for bore cleaning (subpar. e, above).

118. EXCESSIVELY MOIST OR SALTY ATMOSPHERE.

a. When the materiel is not in active use, the unpainted parts should be covered with a film of oil. The bore of the tube and the breech mechanism should be kept heavily oiled with preservative

Preparation of Materiel for Use Under Extreme Conditions

lubricating oil (medium), at all temperatures above +32° F and should be inspected daily for the formation of rust. The materiel should be lubricated more frequently than is prescribed for normal service.

b. Special attention should be given the pivot yoke and thrust bearings. The gun must be traversed throughout its range at least once daily and the gun pointed at a different azimuth each day. The trunnion caps must be kept fully packed with lubricant to exclude moisture from the bearings.

c. In excessively salty atmosphere, the lubricant film should be replaced frequently, as the salt has a tendency to emulsify the oil and destroy its protective qualities.

119. EXCESSIVELY SANDY OR DUSTY CONDITIONS.

a. If considerable dust is present when the gun is operated the lubricant should be removed from the elevating and traversing racks and pinions and the parts should remain dry until the action is over. If surfaces are dry, there is less wear than when they are covered with lubricant mixed with grit.

b. The breech and muzzle covers must be kept on the gun whenever firing conditions permit.

CHAPTER 8 — SEACOAST ARTILLERY: PRESSURE TESTING**120. DEFINITIONS.**

a. **Maximum Pressure.** Maximum pressure is the maximum value of the pressure exerted by the powder gases on the walls of the gun during the firing of a round.

b. **Rated Maximum Pressure.** The rated maximum pressure for any type of gun is the value of the maximum pressure which is specified in the powder specifications as the upper limit of the average pressure which may be developed by an acceptable powder in the form of propelling charges which will impart the specified muzzle velocity to the specified projectile.

c. **Permissible Mean Maximum Pressure.** The permissible mean maximum pressure for any type of gun is that value which should not be exceeded by the average of the maximum pressure developed in a series of rounds fired under any service conditions.

d. **Permissible Individual Maximum Pressure.** The permissible individual maximum pressure for any type of gun is that value which should not be exceeded by the maximum pressure developed by an individual round under any service conditions.

121. USE OF PRESSURE GAGES FOR SEACOAST ARTILLERY.

a. **Minor Caliber Gages.** For seacoast cannon using medium or minor caliber gages, pressure measurements will be limited to shots of trial fire. Extreme care will be taken after each round to insure that no gage remains in the bore. **NOTE:** *Should there be evidence that excessive pressures are being developed, the firing will be stopped and an investigation made to determine the cause.*

122. EXCESSIVE PRESSURES.

a. Excessive pressures are considered as follows:

(1) When the average of the maximum pressures developed in the individual rounds exceeds 41,000 pounds per square inch.

(2) When the maximum pressure developed in any individual round exceeds 43,700 pounds per square inch.

*Seacoast Artillery: Pressure Testing***123. LIMITATIONS ON THE USE OF PROPELLING CHARGES.**

a. The propelling charges should not be used in practice if in the trial shots the mean of the maximum pressure readings exceeds 41,000 pounds per square inch, or the recorded pressure of any round exceeds 43,700 pounds per square inch, or if the difference between the maximum pressures obtained on any two rounds exceeds a value equal to 15 percent of the mean of the group. In the latter case the powder is liable to develop dangerous pressures if firing is continued, or if not actually unsafe, may give excessive velocity variation which will be reflected in the range dispersion.

b. The propelling charges will not be used in subsequent practices if in the record shots the recorded pressure exceeds by more than 5 percent the permissible individual maximum pressure of 43,700 pounds per square inch. The 5 percent increase is based upon the assumption that the coppers in the gages have not been changed between individual rounds. Under such conditions the gage readings are usually somewhat higher than the pressure of any individual round.

124. MAXIMUM PERMISSIBLE PRESSURES.

a. Maximum permissible pressures for Gun M1900 are listed in columns 3, 4, and 5 of table below. Column 2 lists the rated maximum pressure. This pressure is listed in firing tables under captions "Maximum pressure for which gun is designed" or "Maximum pressure."

1	2	3	4	5
Gun	Rated Maximum Pressure (lb per sq in.)	Permissible Mean Maximum Pressure (lb per sq in.)	Permissible Individual Maximum Pressure (lb per sq in.)	Permissible* Maximum Pressure Record Shots (lb per sq in.)
6-in. Gun M1900	38,000	41,000	43,700	45,600

*Pressure recorded by series of rounds without changing coppers.

CHAPTER 9 - REFERENCES

125. PUBLICATIONS INDEXES.

The following publications indexes should be consulted frequently for latest changes or revisions of references given in this chapter and for new publications relating to materiel covered in this manual:

- a. Ordnance supply catalog index (index to SNL's) ASF Cat.
ORD 2
- b. Ordnance major items and combinations, and pertinent publications SB 9-1
- c. List of publications for training (listing CCBP's, FM's, FT's, MTP's, TB's, TM's, TR's, TC's, and LO's) FM 21-6
- d. List of training films, film strips, and film bulletins FM 21-7
- e. Military training aids (listing graphic training aids, models, devices, and displays)..... FM 21-8
- f. List and index of administrative and supply publications (listing new AR's, Cir's, GO's, WDB's, T/O&E's, T/O's, T/E's, T/A's, T/BA's, MR's, RR's, WDP's, SB's, MWO's, and forms) WD Pam. 12-6

126. STANDARD NOMENCLATURE LISTS.

a. Ammunition.

Ammunition, fixed, including subcaliber ammunition for harbor defense, heavy field, and railway artillery ASF Cat.
ORD 11
SNL P-6

Ammunition instruction material for antiaircraft, harbor defense, heavy field, and railway artillery including complete round data..... ASF Cat.
ORD 11
SNL P-8

Charges, propelling, separate loading, 6-in., 155-mm, 8-in., and 240-mm, for harbor defense, heavy field, and railway artillery..... ASF Cat.
ORD 11
SNL P-2

References

Fuzes, primers, blank ammunition, and miscellaneous items for antiaircraft, harbor defense, heavy field, and railway artillery.....	ASF Cat. ORD 11 SNL P-7
Projectiles, separate loading, 6-in., 155-mm, 8-in., and 240-mm, for harbor defense, heavy field, and railway artillery including complete round data	ASF Cat. ORD 11 SNL P-1
Service fuzes and primers for parts, light and medium field artillery, including complete round data	ASF Cat. ORD 11 SNL R-3
b. Cleaning, preserving and lubricating materials; recoil fluids, special oils, and miscellaneous related items	ASF Cat. ORD 5 SNL K-1
c. Gun Materiel.	
Carriage, barbette, 6-in., M1900, M1910 and M1910 (casemate)	ASF Cat. ORD 7 SNL E-16
Gun, 6-in., M1900, and 1908MII.....	ASF Cat. ORD 7 SNL E-4
d. Sighting Equipment.	
Mount, telescope, M1904, M1904A1, M1904MI, M1904MIA1	ASF Cat. ORD SNL F-135
Telescope, 3-in., M1904, M1904MI and M1904MII	ASF Cat. ORD SNL F-135

References

127. EXPLANATORY PUBLICATIONS.**a. Ammunition.**

Ammunition, general	TM 9-1900
Ammunition inspection guide	TM 9-1904
Artillery ammunition	TM 9-1901
Ballistic data, performance of ammunition.....	TM 9-1907
Coast artillery ammunition	TM 4-205

b. Army Regulations.

Qualifications in arms and ammunition training allowances	AR 770-10
Range regulations for firing ammunition for training and target practice.....	AR 750-10

c. Care and Preservation.

Cleaning, preserving, sealing lubricating and related materials issued for ordnance materiel	TM 9-850
Decontamination	TM 3-220
Defense against chemical attack.....	FM 21-40
Firing preparations safety precautions, care and service of materiel	FM 4-20
Preservation and care of seacoast defense materiel	TM 4-245
War Department Lubrication Order.....	LO 9-424

d. General.

Basic Maintenance Manual	TM 37-250
Coast artillery gunners' instruction, fixed seacoast artillery, expert gunners	TM 4-310
Coast defense	FM 31-10
Seacoast artillery weapons	TM 4-210
Seacoast artillery: gunnery	FM 4-10
Seacoast artillery: service of the piece—6-inch gun on barbette carriage	FM 4-75
Standard artillery and fire control materiel.....	TM 9-2300

e. Sighting and Fire Control Equipment.

Auxiliary fire-control instrument (field glasses, eyeglasses, telescopes, and watches).....	TM 9-575
Seacoast artillery: fire control and position firing	FM 4-15

References

128. FIRING TABLES.

a. Gun, 6-in., M1900.

SHELL, A.P., 108-lb, M1900, w/fuze BD, Mk. V	}	FT 6-C-2
SHELL, A.P., C.I., 108-lb, M1911		
SHOT, A.P., 108-lb, M1911, w/fuze BD, Mk. V		
SHELL, H.E., 90-lb, Mk. 2, w/fuze PD, M47....		FT 6-D-2, C3
SHELL, H.E., 90-lb, Mk. 2A2, w/fuze PD, M51 and mods.		FT 6-F-1
SHOT, A.P., 105-lb, Mk. 33, w/fuze, BD, M60....		FT 6-E-2, C1
b. Gun Subcaliber, 1.457-in. (1-pdr).		
SHELL, 1.1 lb		FT 37-C-2

INDEX

A	Page	Page	
Accessories		Cleaning and preserving materials... 54	
care and preservation (gun and carriage)	35	Covers	
general discussion		breech and muzzle	88
gun and carriage	83	sponge	91
subcaliber	118	Cradle	
Adapter, front	113	care and preservation	46
Ammunition		description	13
authorized rounds		general	12
<i>general</i>	71		
tables	72, 74	D	
care, handling, and preservation	70	Dummy ammunition	
classification and identification...	67	data	72, 74
data	4	projectile.....	24, 72, 74, 80
dummy	24, 72, 73, 74, 80	propelling charge	72, 73, 80
lot number	67		
marking for shipment	81	E	
packing	79	Electrical contact check	19
preparation for firing.....	19, 77	Electrical equipment	58
weight zone markings	68	Elevating handwheel, backlash	32
(See also Subcaliber ammunition)		Elevating mechanism	
Artillery gun book	1, 84	care and preservation	46
		description	15
B		general	12
Bar screwdrivers	85	inspection	57
Barbette carriage (See Carriage, barbette)		malfunctions and corrections	32
Bore greasing device	85	Elevation data	4
Breech		Equipment	
closing	8	care and preservation of organiza-	
inspection	18	tional	35
opening	21	inspection of electrical	58
Breech mechanism		(See also Sighting equipment)	
care and preservation	37	Extractors	
description	8	packing	98
disassembly	40	subcaliber equipment	
inspection	56	gun and clip	120
malfunctions and corrections	30	hand	121
preparation for inactive or active season	49		
repair	59	F	
Breechblock		File cleaner (w/scorer)	72
inspection	56	Filling funnel	92
removal	41	Firing circuit, inspection	58
Brushes	83	Firing mechanism	
		care and preservation	40
C		description	11
Care and preservation	33	disassembly	41
Carriage, barbette		inspection	18, 56
care and preservation	46	Firing mechanism box	93
description	12	Firing mechanism contact clip	58

Index

F — Contd.	Page		Page
Firing the gun		Lubrication	
operations		by higher echelon	30
after firing	23	equipment for	25
during firing	24	general servicing instructions	24
preparation for firing	18	Lubrication Order	24
Force pump (plumber's)	93		
Fuzes		M	
classification	77	Malfunctions and corrections	30
description	79	Mount, gun, traversing	21
G		Mount, telescope (See Telescope Mount)	
Gas check pad seat		O	
care and preservation	38	Obturation (breech)	8
inspection	56	Obturator, inspection	57
Gun M1900		Obturator spindle plate (subcaliber equipment)	122
characteristics		Optics, care and preservation	66
gun	2	P	
projectiles	74	Packing extractor	98
data	3	Pedestal (barbette carriage)	
description	5	description	12
inspection and adjustment	55	inspection	57
malfunctions and corrections	30	Pivot thrust rollers	51
preparation for firing	18	Pivot yoke (carriage)	
preparation for inactive or active season	49	care and preservation	49
to elevate or depress	21	description	13
to load	21	Pressure gages (seacoast artillery)	
(See also Subcaliber gun)		maximum permissible pressures	129
Gun barrel		uses	128
cleaning	36	Primer flame baffle	98
description	5	Primer seat cleaning reamer	98
Gun bore		Primers	
adjustment	55	data	80
cleaning	18	electric M30	76
inspection	18, 55	friction M1914	77
Gun emplacement, check drainage facilities	51	Projectiles	
Gun mount	21	authorized round data	72, 74
Gunner's drill	94	preparation for firing	77
Gunner's platforms	18	Propelling charge gage	99
Gunner's pouch	96	Propelling charges	
Gunner's punch	96	limitations on the use of (seacoast artillery)	129
Gunner's sleeves	96	single-section and dummy	73
L			
Lanyard	96		
Lighting circuit, inspection	58		
Lighting system, description	17		
Loading tray	18		

Index

R	Page		Page
Rammer		Subcaliber accessories	
caution	101	<i>general discussion</i>	118
description	100	list of	119
Recoil, slow	32	Subcaliber ammunition	
Recoil mechanism		data	72
care and preservation	44	<i>general discussion</i>	82
data	4	Subcaliber equipment	
description	13	<i>general discussion</i>	109
general	12	preparation of materiel for use	
inspection	57	<i>under extreme conditions</i>	125
malfunctions and corrections	31	Subcaliber gun	
preparation for inactive or active		adjustment	116
service	51	data	3
Recoil oil, <i>checking</i>	20	inspection and list of parts	118
Recoil slide, inspecting surfaces	56	installation	115
Recoil system	14	lubrication instructions	117
Records and reports	1	operation and detailed description	111
Recuperator spring cylinders	14	removal, care, and preservation	117
		Supports, shield	18
		T	
		Telescope mount, <i>description</i>	60
		Telescopes	
		description	62
		differences between models	63
		<i>Thrust bearing, inspection</i>	57
		Traversing	
		data	4
		the mount	21
		<i>Traversing handwheel, backlash</i>	33
		Traversing mechanism	
		care and preservation	46
		description	16
		<i>general</i>	12
		inspection	58
		malfunctions and corrections	33
		Tube group	
		assembly and disassembly	114
		<i>general discussion</i>	111
		W	
		Wrenches	108