

U
408.3
.A5
TM9-
1751

TM 9-1751

WAR DEPARTMENT TECHNICAL MANUAL

ORDNANCE MAINTENANCE

9-Cylinder, Radial, Gasoline Engine (Continental Model R975-C1)

DECLASSIFIED
Auth: NND 775126
By NNHP NARS 3-3-78

This record was previously
allocated to RG 319 (Entry
No. 382) and is now assigned
to RG 287.

WAR DEPARTMENT

• 19 APRIL 1944

FOR ORDNANCE PERSONNEL ONLY

WAR DEPARTMENT TECHNICAL MANUAL

TM 9-1751

ORDNANCE MAINTENANCE

**9-Cylinder,
Radial, Gasoline Engine
(Continental Model R975-C1)**



WAR DEPARTMENT

19 APRIL 1944

9 051795
PROPERTY OF U. S.

WAR DEPARTMENT
Washington, D. C., 19 April 1944

TM 9-1751, Ordnance Maintenance: 9-cylinder, Radial, Gasoline Engine (Continental Model R975-C1), is published for the information and guidance of all concerned.

[A.G. 300.7 (22 Nov 43)
O.O.M. 461/Rar. Ars. (4-21-44)]

By ORDER OF THE SECRETARY OF WAR:

G. C. MARSHALL,
Chief of Staff.

OFFICIAL:

J. A. ULIO,
*Major General,
The Adjutant General.*

DISTRIBUTION: R 9 (4); Bn 9 (2); C 9 (5).

(For explanation of symbols, see FM 21-6.)

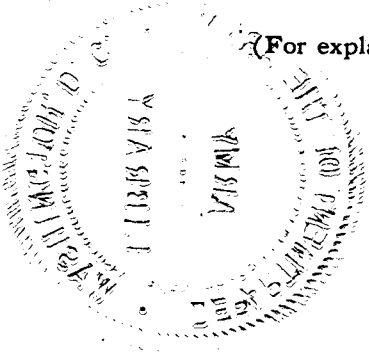

CONTENTS

Trans. 1000

	Paragraphs	Pages
CHAPTER 1. INTRODUCTION	1- 2	4- 7
CHAPTER 2. R975-C1 ENGINE (CONTINENTAL)	3-38	8-199
SECTION I. Engine description and data	3- 4	8- 17
II. Disassembly of engine into sub-assemblies	5- 7	17- 51
III. Introduction to overhaul of engine subassemblies	8-12	51- 58
IV. Overhaul of the crankcase front section	13-17	58- 63
V. Overhaul of the crankcase main section	18-22	63-125
VI. Overhaul of the diffuser section..	23-27	125-139
VII. Overhaul of the rear section.....	28-32	139-163
VIII. Assembly of the engine.....	33-34	163-187
IX. Testing after overhaul.....	35-37	188-189
X. Table of limits.....	38	190-199
CHAPTER 3. CLUTCH	39-45	200-220
SECTION I. Description and data.....	39-40	200-205
II. Removal, disassembly, cleaning, inspection, repair, and assembly	41-44	206-219
III. Table of limits.....	45	219-220
CHAPTER 4. SPECIAL TOOLS	46	221-223
REFERENCES		224-226
INDEX		227-236

★This manual supersedes TM 9-1751, 28 Feb 42 (reprinted as TM 9-1730C), together with Change 1, 17 Jul 42 and Change 2, 22 Mar 43. It also supersedes TB 1751-1, 1 Jan 42; TB 1751-3, 1 Jan 42; TB 1751-4, 1 Jan 42; TB 1751-5, 1 Jan 42; TB 1751-6, 22 Apr 42; TB 1751-7, 2 May 42; TB 1751-9, 18 Jun 42; TB 1751-10, 3 Jul 42; TB 1751-11, 9 Jul 42; TB 1751-13, 27 Jul 42; TB 1751-15, 22 Apr 43; TB 1751-16, 4 May 43; TB 1751-17, 7 May 43. This manual also supersedes pertinent information from TB 1700-4, 1 Jan 42; TB 1700-21, 5 May 43; and TB 1700-37, 15 May 43.

**ORDNANCE MAINTENANCE — 9-CYLINDER, RADIAL, GASOLINE ENGINE
(CONTINENTAL MODEL R975-C1)**

CHAPTER 1

INTRODUCTION

I. SCOPE.

a. Purpose. The instructions contained in this manual are for the information and guidance of personnel charged with the maintenance and repair for the Continental R975-C1 engine. These instructions are supplementary to Field Manuals and Technical Manuals prepared for the using arms. This manual does not contain information which is intended primarily for the using arms, since such information is available to ordnance maintenance personnel in 100-series Technical Manuals or Field Manuals.

b. Contents. This manual contains a description of and procedure for disassembly, inspection, repair and assembly of the Continental R975-C1 engine.

c. Accessories. The present accessories used with this engine and the publications which contain the disassembly, inspection, repair, and assembly instructions for these accessories are:

ITEM	MODEL	TM NO.	TM TITLES
Cranking motor	DR-1108685	TM 9-1825A	Ordnance Maintenance: Electrical Equipment (Delco Remy)
	EC-817	TM 9-1750D	Ordnance Maintenance: Accessories for Wright R975-EC2 Engines for Medium Tanks M3 and M4
Generator	EC-314-31	TM 9-1750D	Ordnance Maintenance: Accessories for Wright R975-EC2 Engines for Medium Tanks M3 and M4
Fuel pump	AC-BF	TM 9-1828A	Ordnance Maintenance: Fuel Pumps

INTRODUCTION

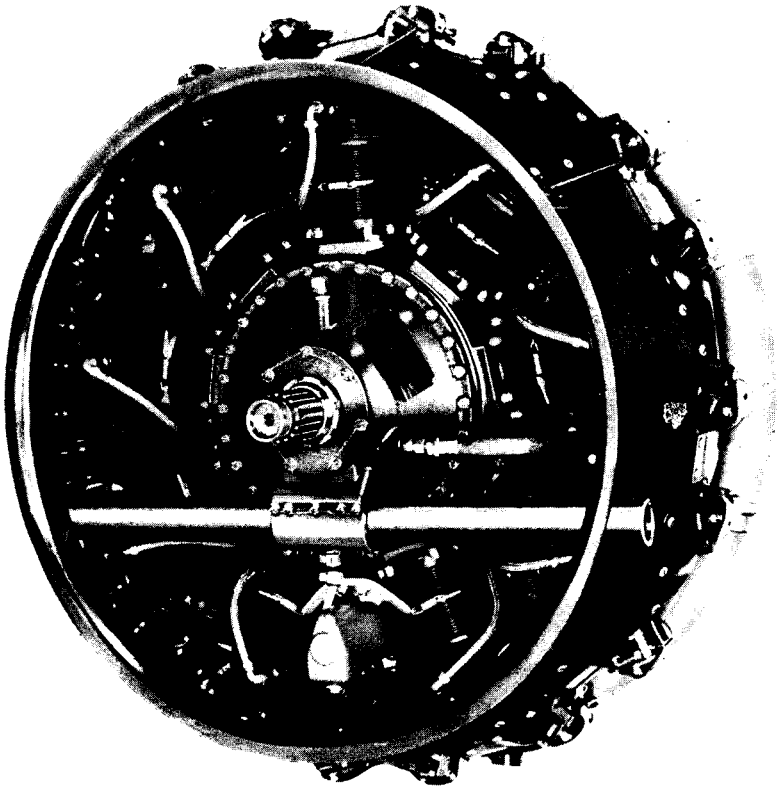

RA PD 309751

Figure 1 — R975-C1 Engine — Left Front View

ITEM	MODEL	TM NO.	TM TITLES
	RE-F8	TM 9-1750D	Ordnance Maintenance: Accessories for Wright R975-EC2 Engines for Medium Tanks M3 and M4
Carburetor	BS-NAR9D	TM 9-1826B	Ordnance Maintenance: Carburetors (Stromberg)
	BS-NAR9G	TM 9-1826B	Ordnance Maintenance: Carburetors (Stromberg)

**ORDNANCE MAINTENANCE — 9-CYLINDER, RADIAL, GASOLINE ENGINE
(CONTINENTAL MODEL R975-C1)**

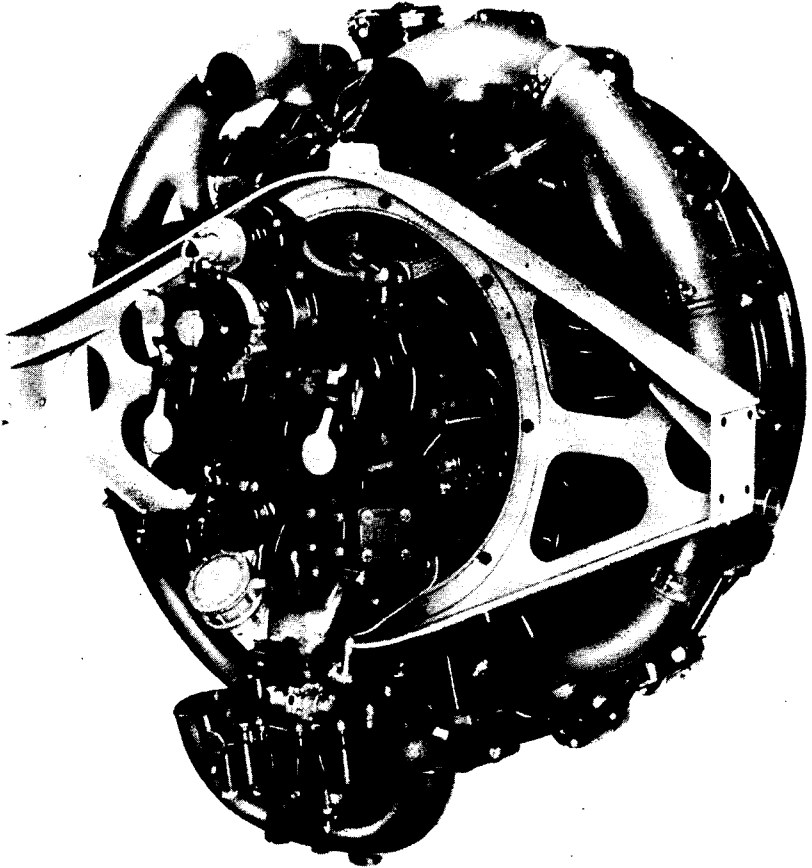

RA PD 309752

Figure 2 — R975-C1 Engine — Right Rear View

ITEM	MODEL	TM NO.	TM TITLES
Magnetos	SCI-VAG-9-DFA	TM 9-1750D	Ordnance Maintenance: Accessories for Wright R975-EC2 Engines for Medium Tanks M3 and M4
	BO-MJT9A306	TM 9-1750C	Ordnance Maintenance: American Bosch Magnetos, MJT7A302, MJT-9A304, and MJT-9A306

INTRODUCTION

2. RECORD OF MODIFICATIONS.

a. **Description.** Every vehicle is supplied with a copy of AGO Form No. 478 which provides a means of keeping a record of each MWO completed or major unit assembly replaced. This form includes spaces for the vehicle name and U. S. A. registration number, instructions for use, and information pertinent to the work accomplished. It is very important that the form be used as directed and that it remain with the vehicle until the vehicle is removed from service.

b. **Instructions for Use.** Personnel performing modifications or major unit assembly replacements must record clearly on the form a description of the work completed and must initial the form in the columns provided. When each modification is completed, record the date, hours and/or mileage, and MWO number. When major unit assemblies, such as engines, transmissions, transfer cases, are replaced, record the date, hours and/or mileage, and nomenclature of the unit assembly. Minor repairs and minor parts and accessory replacements need not be recorded.

c. **Early Modifications.** Upon receipt by a third or fourth echelon repair facility of a vehicle for modification or repair, maintenance personnel will record the MWO numbers of modifications applied prior to the date of AGO Form No. 478.

**ORDNANCE MAINTENANCE — 9-CYLINDER, RADIAL, GASOLINE ENGINE
(CONTINENTAL MODEL R975-C1)**

CHAPTER 2

R975-C1 ENGINE (CONTINENTAL)

Section 1

ENGINE DESCRIPTION AND DATA

3. DESCRIPTION.

a. **Identification.** Throughout this manual the flywheel end of the engine is referred to as the "front" and the antiflywheel end (accessory case) as the "rear." The terms "right" and "left" designate the sides of the engine as viewed from the rear (engine in vertical position). "Top" and "bottom" are referred to as viewing the engine in such a position that its carburetor points directly downward and the crankshaft extends horizontally. Directions of rotation are determined by looking from the rear of the engine toward the front. The cylinders are numbered in a clockwise direction, commencing with the top cylinder, designated as cylinder No. 1.

b. **Serial Numbers.** The following are serial numbers identifying the engine: Numbers 122699 through 130925 and 300001 up.

c. **Accessory Drives.** The direction of rotation of the crankshaft is clockwise. The direction of rotation and ratio to crankshaft speed of the various accessory drives as viewed from the rear of the engine are given in the following table:

Accessory Drive	Rotation	Ratio of Drive to Crankshaft Speed
Cranking Motor	Counterclockwise	0.80 to 1
Generator	Clockwise	2.40 to 1
Magnetos	Counterclockwise	1.125 to 1
Upper Tachometer	Counterclockwise	0.50 to 1
Lower Tachometer	Clockwise	0.50 to 1
Supercharger Impeller	Clockwise	10.15 to 1
Fuel Pump	Counterclockwise	1.159 to 1

d. Engine Components.

(1) **FRONT SECTION.** The front section is a conical-shaped aluminum casting which houses the crankshaft thrust ball bearing, a front oil seal assembly, and a scavenge oil pump. A heavy boss cast on the outside of the housing is machined and fitted with studs and a cap to hold the engine front support tube.

R975-C1 ENGINE (CONTINENTAL)

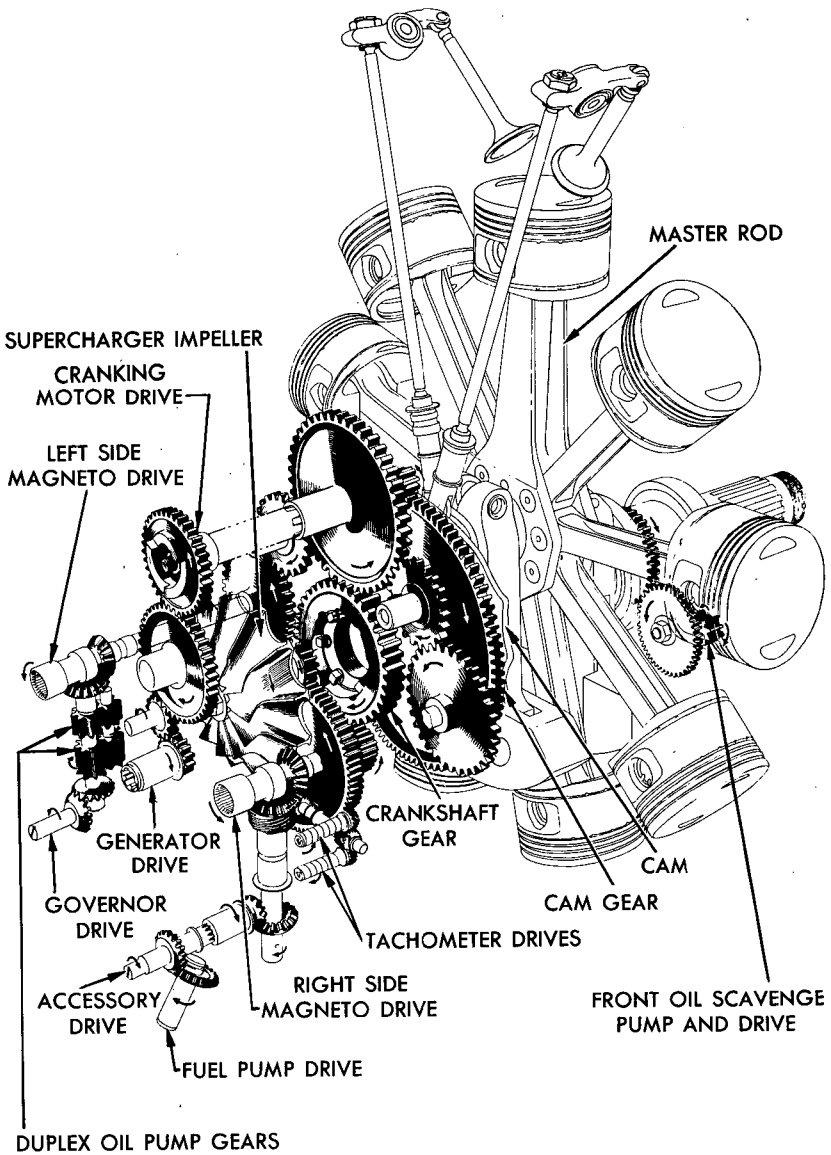

RA PD 336196

Figure 3 — Gear Train Diagram

ORDNANCE MAINTENANCE — 9-CYLINDER, RADIAL, GASOLINE ENGINE
(CONTINENTAL MODEL R975-C1)

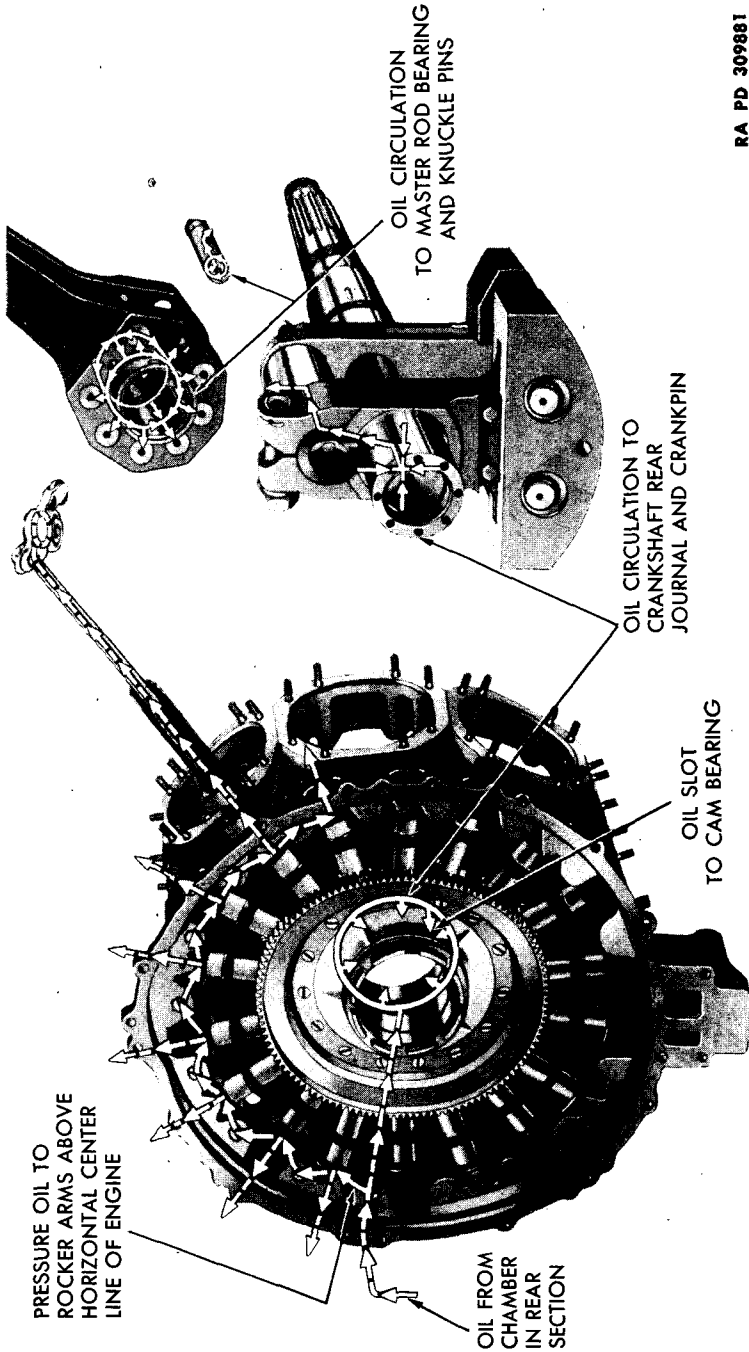

RA PD 309881

Figure 4 — Pressure Oil Circulation Line "A"

R975-C1 ENGINE (CONTINENTAL)

(2) **FRONT MAIN BEARING.** The front main bearing support is a light metal diaphragm, the principal function of which is to support the crankshaft front (roller) bearing. Two holes drilled through the diaphragm constitute a part of the engine breather system.

(3) **MAIN SECTION.** The main section of the engine consists of the cylinders, pistons, connecting rods, crankshaft, and crankcase main section casting. The cam and cam followers (tappets) are also housed in this part of the engine. Connecting rods are the conventional master and articulated types used in most radial engines.

(4) **DIFFUSER SECTION.** The diffuser section is a light metal diaphragm, the rear side of which supports the impeller and forms the front wall of the diffuser and distribution chambers. This section supports the supercharger impeller, the impeller drive gears, the forward ends of the accessory drive (magneto) and cranking motor shafts, and the accessory drive idler gears. Parting surfaces of the diffuser section are machined to fit between the main and rear surfaces.

(5) **REAR SECTION.** The rear section of the engine supports the accessory drives and has machined pads for mounting the various accessories. The forward end of this section forms the rear wall of the diffuser and distribution chambers. Engine mounting bosses located at the intake pipe connections are drilled for attachment of the engine support beam. Drive is provided in the rear section for the engine oil pump, a governor, a fuel pump, a vacuum or hydraulic pump (as required), two magnetos, a generator, tachometers (either right or left hand rotating), and a cranking motor.

e. Lubrication System.

(1) **MAIN OIL PUMP.** A duplex gear-type pump is mounted on the lower left side of the crankcase rear section. This pump consists primarily of two sections, a pressure and a scavenge (or suction) section. The pressure section of the pump supplies oil for lubrication of all working parts in the engine. The scavenge section returns oil from the rear of the sump back to the supply tank.

(2) **CIRCULATION.** Oil from the pressure pump is forced into a hollow chamber located in the crankcase rear section just above and to the left of the pump. This oil chamber serves as the source of supply for the three main pressure lines into the engine. These main pressure lines conform to the separate circulating systems illustrated in figures 4, 5, 6, and 7, and are designated as "A," "B," and "C" respectively. Circulating line "A" supplies oil under pressure to the valve mechanisms above the horizontal center line of the engine, the crankshaft rear bearing, the crankpin journal, and the master and articulated connecting rod bearings. Circulating line "B" conducts oil

ORDNANCE MAINTENANCE — 9-CYLINDER, RADIAL, GASOLINE ENGINE
(CONTINENTAL MODEL R975-C1)

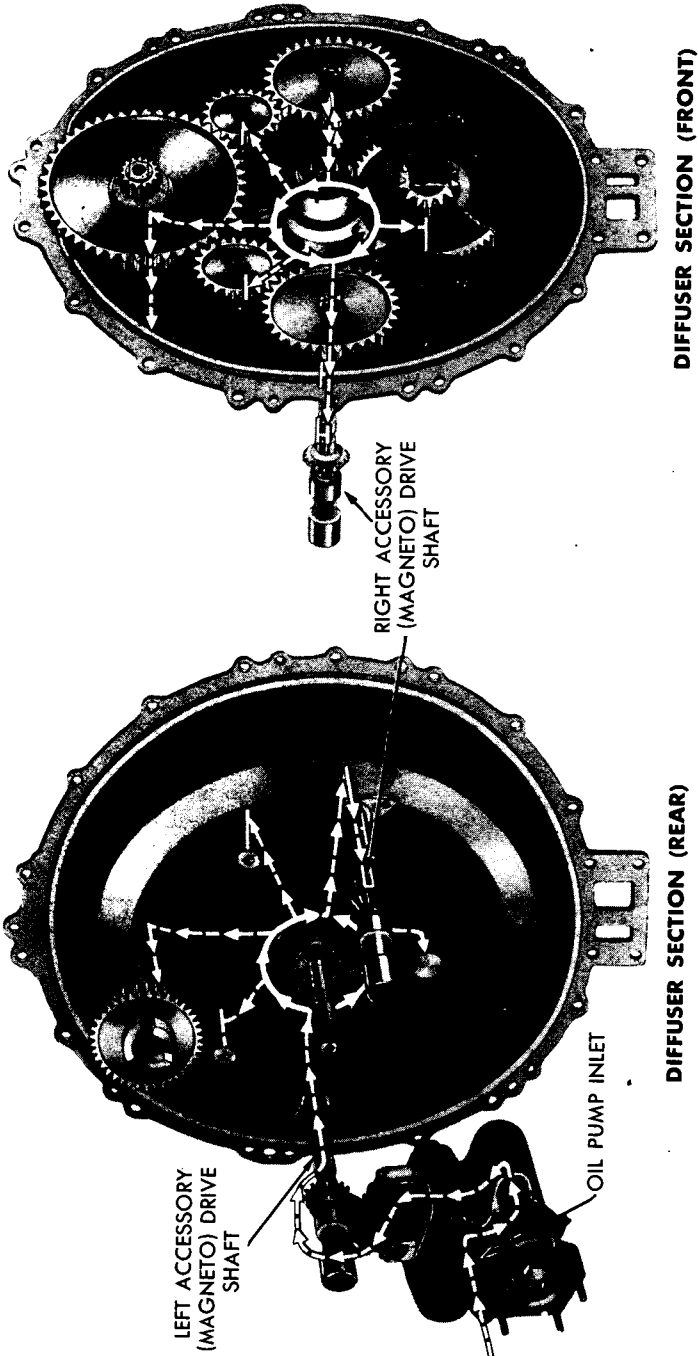

RA PD 309862

Figure 5 — Pressure Oil Circulation Line "B"

ORDNANCE MAINTENANCE — 9-CYLINDER, RADIAL, GASOLINE ENGINE
(CONTINENTAL MODEL R975-C1)

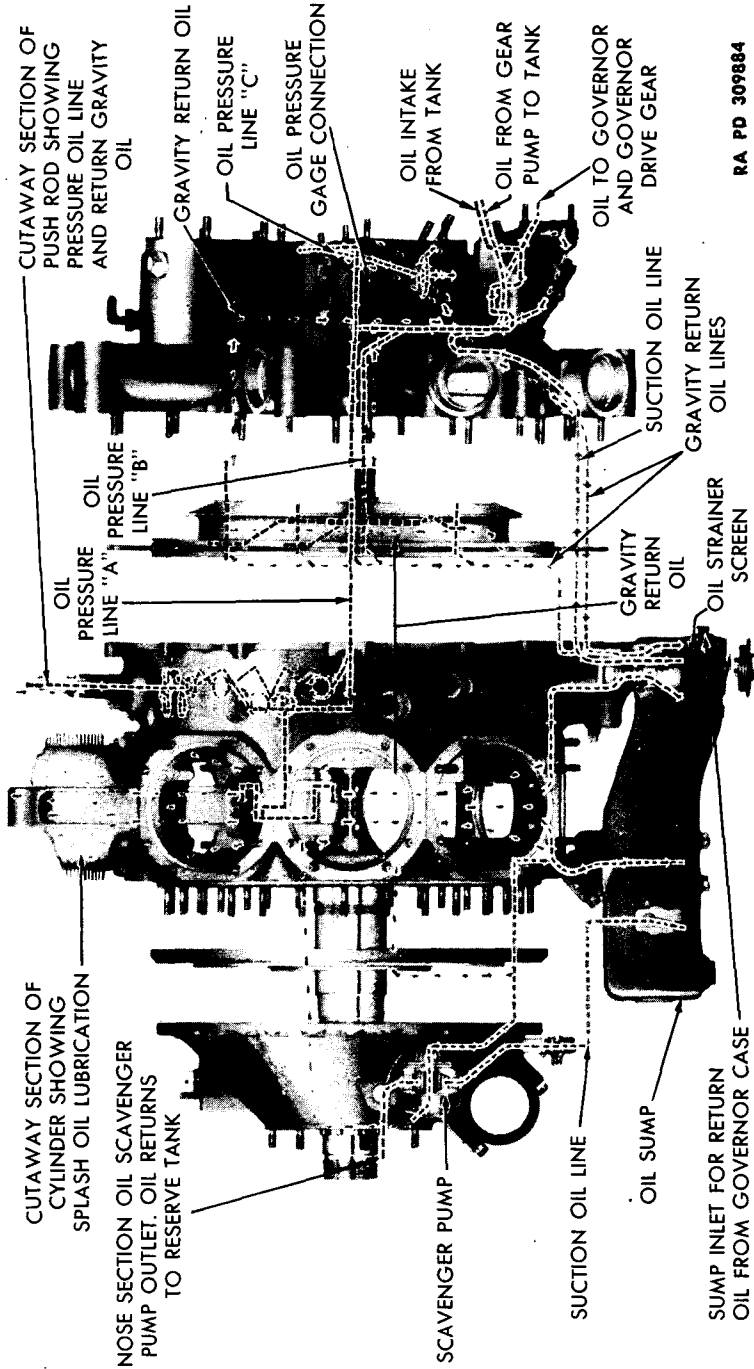

RA PD 309884

Figure 7 — Oil Flow Diagram

R975-C1 ENGINE (CONTINENTAL)

forward through the left accessory drive shaft to connect with drilled passages to all sleeve bushings in the diffuser section. The right side accessory drive shaft connects to an outlet from the "B" line in the diffuser section to obtain oil for lubrication of its bushings. Circulating line "C" crosses over the rear face of the crankcase rear section through drilled passages to provide lubrication for the generator drive and idler gears and the three-way accessory drive adapter and housing.

(3) **RETURN OIL.** Return oil to the supply tank of the vehicle is handled by two scavenge pumps; one a section of the main oil pump, and the other an auxiliary pump located in the crankcase front section. All lubricating oil pumped into the engine drains into a sump located just below the crankcase main section and midway between cylinder Nos. 5 and 6. Oil in the rear part of the sump is drawn through a strainer and through a passage in the crankcase main section to the scavenge section of the main oil pump where it is returned to the tank. Oil from the front part of the sump is drawn through an external tube to the front scavenge pump where it is also returned to the supply tank.

4. DATA.

a. General.

Model	R975-C1
Type ...	Single-row 4-cycle, air-cooled static radial, and supercharged
Number of cylinders.....	9
Bore	5 in.
Stroke	5.5 in.
Piston displacement	973 cu in.
Engine direction of rotation (looking at antiflywheel end)	Clockwise
Rated H.P.	400 to 2,400 rpm
Compression ratio	5.7 to 1
Supercharger impeller diameter.....	6 $\frac{7}{8}$ in.
Supercharger impeller ratio.....	10.15 to 1
Serial number location....	Name plate on front section and rear case
Size of engine crated.....	Length 55.75 in., width 53.50 in., height 51.875 in.
Shipping weight.....	Engine (complete) 955 lb, box 630 lb, total 1,585 lb

**ORDNANCE MAINTENANCE – 9-CYLINDER, RADIAL, GASOLINE ENGINE
(CONTINENTAL MODEL R975-C1)**

b. Ignition.

- Ignition firing order 1-3-5-7-9-2-4-6-8
- Magnets Scintilla-type VAG-9-DFA, Bosch-type MJT-9A-306
- Magneto-rotation Counterclockwise
- Max rpm drop for operation on single Magneto 100 rpm from approx
2,100 rpm on prop load
- Breaker point gap (Bosch) 0.008 in. to 0.010 in.
- Breaker point gap (Scintilla) 0.012 in.
- Magneto timing
(Scintilla) . . (Right) Magneto spark timing 25 deg B.T.C. full adv
(Left) Magneto spark timing 25 deg B.T.C. full adv
- Magneto timing
(Bosch) (Right) Magneto spark timing 4 deg B.T.C. full ret
(Left) Magneto spark timing 4 deg B.T.C. full ret
- Magneto Wiring:

Cylinder Number	Magneto Block Number
1	1
2	6
3	2
4	7
5	3
6	8
7	4
8	9
9	5

- Spark plugs Champion 63-S
- Spark plug gap 0.018 to 0.020 in.

c. Valve Timing.

- (1) CAM CMC 200742 (Identified by use of bolts on cam hub):
- Valve timing clearance Engine cold intake and exhaust 0.070 in.
- Intake valve opens 3 deg A.T.C.
- Intake valve closes 34 deg A.B.C.
- Exhaust valve opens 61 deg B.B.C.
- Exhaust valve closes 8 deg A.T.C.
- Valve clearance reset for running cold on high lobe,
intake and exhaust 0.006 in.

R975-C1 ENGINE (CONTINENTAL)

(2) CAM CMC 202347 (Identified by use of rivets on cam hub):

Valve timing clearance	Engine cold intake and exhaust	0.070 in.
Intake valve opens		8 deg B.T.C.
Intake valve closes		34 deg A.B.C.
Exhaust valve opens		56 deg B.B.C.
Exhaust valve closes		19 deg A.T.C.
Valve clearance reset for running cold on high lobe, intake and exhaust		0.006 in.

Section II

DISASSEMBLY OF ENGINE INTO SUBASSEMBLIES

5. INTRODUCTION.

a. **General.** In addition to the notes given during various stages of disassembly, close observation must be made of all parts immediately upon removal from the engine for signs of scoring or burning resulting from undue friction. Valuable evidence of defects can be obtained when the oil or loosened surface of the metal is present, rather than after the whole has been washed and laid out for examination. Consequently, each part must be carefully examined before being cleaned, and reports made concerning any unusual conditions such as excessive sludge, the collection of metallic chips, or charred oil deposits.

b. **Cleaning.**

(1) Suspend the engine from a chain hoist while the exterior is sprayed with an approved cleaner to remove all traces of dirt and grease. Use dry-cleaning solvent in the spray gun; however, due to the extreme fire hazard resulting from high vapor concentrations produced by spraying inflammable liquids, use this method only in the open air or in ventilated fireproof spray booths. It is important when spraying indoors that all equipment be grounded to prevent static discharge, and all lighting and electrical equipment be vaporproof. Under no circumstances will gasoline be used for spray cleaning.

(2) When any operation involves the removal of spark plugs, replace them immediately with plastic dummy plugs to prevent the entrance of foreign material into the cylinder. If, during certain operations, it is necessary to turn the crankshaft, use vented dummy plugs. If vented plugs are not available, they may be prepared by drilling six $\frac{3}{32}$ -inch holes approximately $\frac{7}{16}$ inch from the shoulders at the cylinder ends of regular dummy plugs. Countersink the holes to $\frac{1}{8}$ -inch diameter and paint the vented plugs a bright color to differentiate them from the regular dummy plugs.

**ORDNANCE MAINTENANCE — 9-CYLINDER, RADIAL, GASOLINE ENGINE
(CONTINENTAL MODEL R975-C1)**

6. PRELIMINARY OPERATIONS.

a. **Remove Fuel Pump (A-C).** Remove the four palnuts and nuts holding the fuel pump and drive adapter to the three-way accessory drive unit. The fuel pump will be removed together with right angle drive adapter and fuel pump drive gear (fig. 8).

b. **Remove Fuel Pump (Romec).** The Romec fuel pump will be removed by disengaging the square-type drive shaft and the pump body from the drive adapter flange. Then remove the drive adapter together with the drive gear (fig. 8). If it is necessary to use a fiber hammer to assist removal of the pump, tap gently around the edges, and avoid striking at or near the parting flanges. **CAUTION:** *Do not use a screwdriver or other metal tool to pry under the edges of the fuel pump or the adapter.*

c. **Remove Carburetor, Throttle Box, and Carburetor Elbow.** Remove cotter pin from the throttle yoke clevis pin, and withdraw the pin. Disconnect the yoke from the throttle box. Replace clevis pin in yoke, and secure it with wire to prevent misplacement. Detach lock wire from the four elbow attaching nuts and the two elbow support bracket bolts. Remove nuts and bolts. Lift off the carburetor, throttle box, and carburetor elbow as a unit (fig. 9). **NOTE:** *Support the unit while removing the last bolt.*

d. **Remove Cranking Motor.** Remove the cranking motor and generator support clamps. Remove the cotter pins and eight nuts from bolts attaching the two plates to the cranking motor and generator clamps. Remove lock wire and screw which retain cranking motor clamp in position, and remove the clamp. Remove cotter pin, nut, and bolt holding the generator clamp, and remove the clamp. Remove lock wire, nuts, and washers from studs holding cranking motor base flange to crankcase rear section, using wrench (41-W-871-45). Hold cranking motor firmly, and withdraw straight out (fig. 10). **NOTE:** *Keep cranking motor supported while removing the final nut.*

e. **Remove Generator.** Remove lock wire. Remove nuts from the four studs holding the generator base flange to the crankcase rear section, using wrench (41-W-636-550). Support the generator while removing the last nut. Pull generator straight out from engine (fig. 11).

f. **Remove Governor.** Remove the four palnuts, nuts, and washers from studs holding the governor flange, and remove the governor (fig. 12).

g. **Remove Magnetos.** Remove the two cap screws attaching the wiring harness conduit adapter to the magneto distributor block

R975-C1 ENGINE (CONTINENTAL)

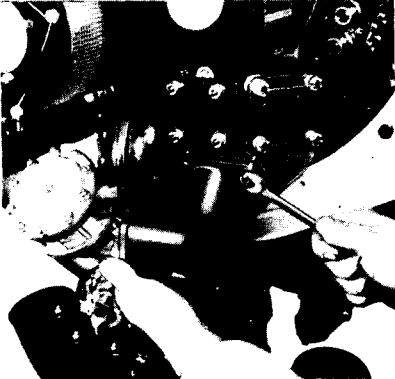

**A - LOOSENING A-C PUMP
FLANGE NUTS**

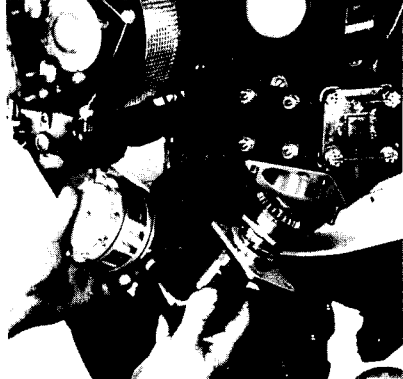

**B - WITHDRAWING OR
INSTALLING A-C PUMP**

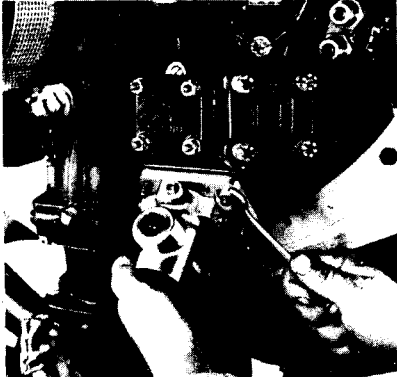

**C - LOOSENING ROMEc PUMP
FLANGE NUTS**



**D - REMOVING OR INSTALLING
ROMEc PUMP**

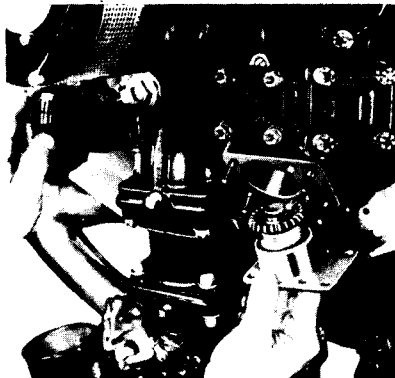

**E - WITHDRAWING OR INSTALLING
ROMEc PUMP DRIVE ADAPTER**

RA PD 309777

Figure 1. Removing A-C and ROMEc Fuel Pumps

ORDNANCE MAINTENANCE — 9-CYLINDER, RADIAL, GASOLINE ENGINE
(CONTINENTAL MODEL R975-C1)

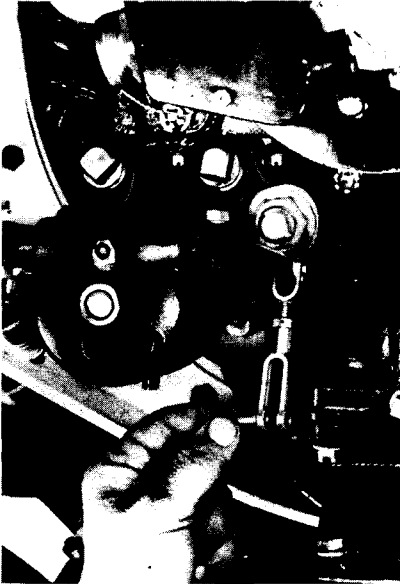

**A - REMOVE OR INSTALL THROTTLE
ROD YOKE PIN**

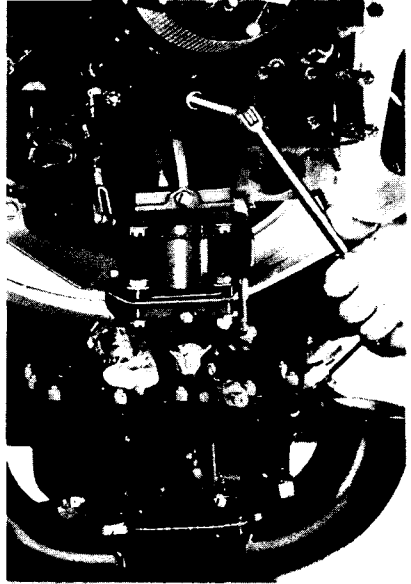

**B - REMOVE CARBURETOR FLANGE
NUTS**

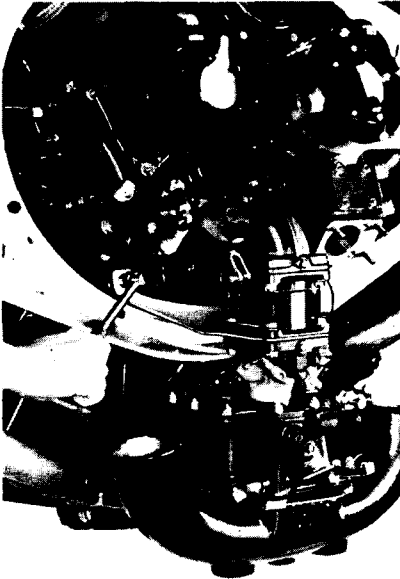

**C - REMOVE OR INSTALL CAR
BURETOR ELBOW BRACE
SCREWS**

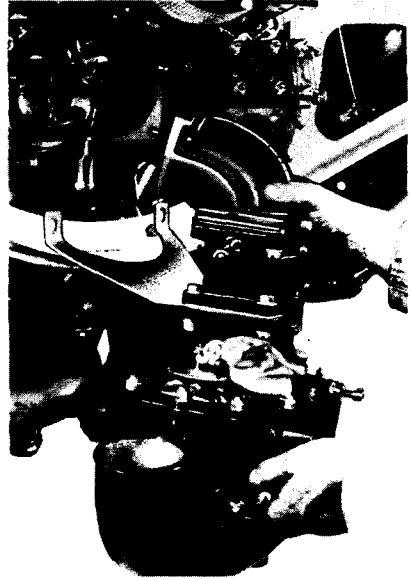

**D - WITHDRAW OR INSTALL CAR
BURETOR ELBOW AND
THROTTLE BOX**

**Figure 9 — Replacement of Carburetor Elbow, Governor Throttle Box,
and Carburetor**

RA PD 309778

R975-C1 ENGINE (CONTINENTAL)

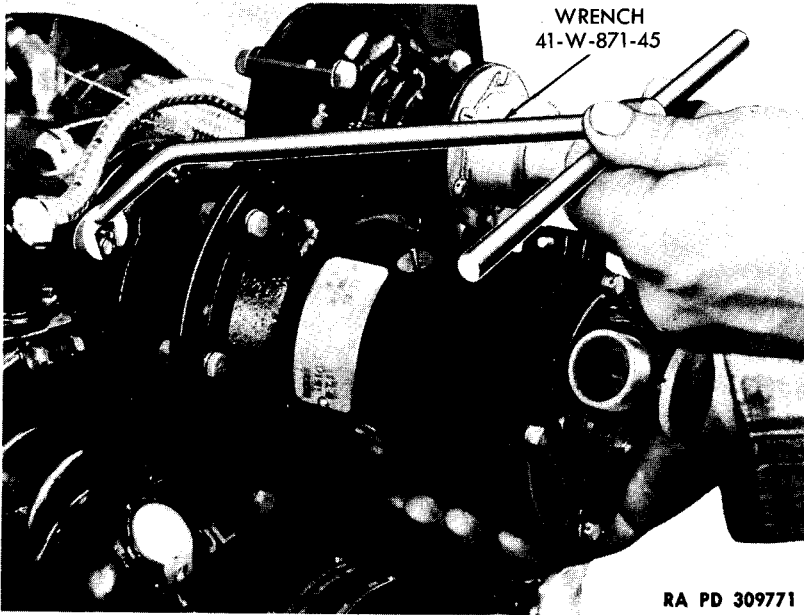

Figure 10 – Removing Cranking Motor Flange Nuts

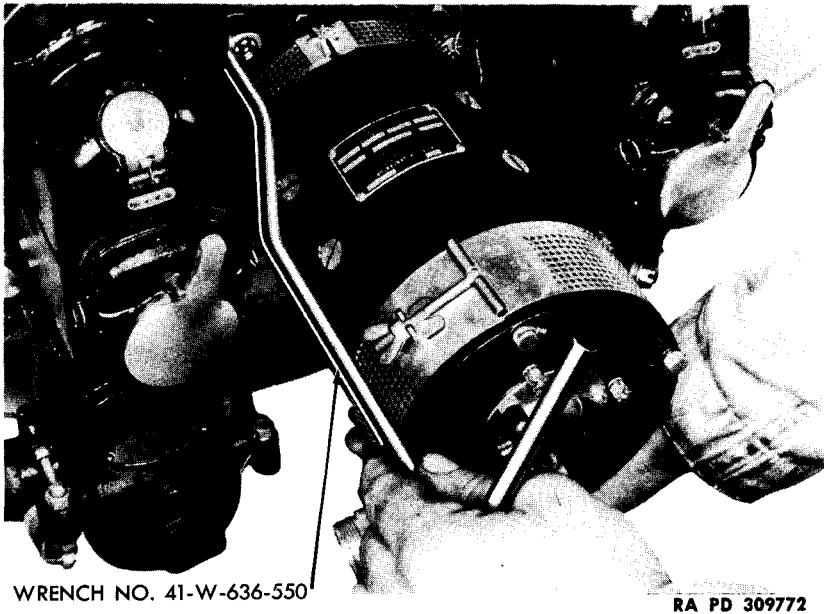
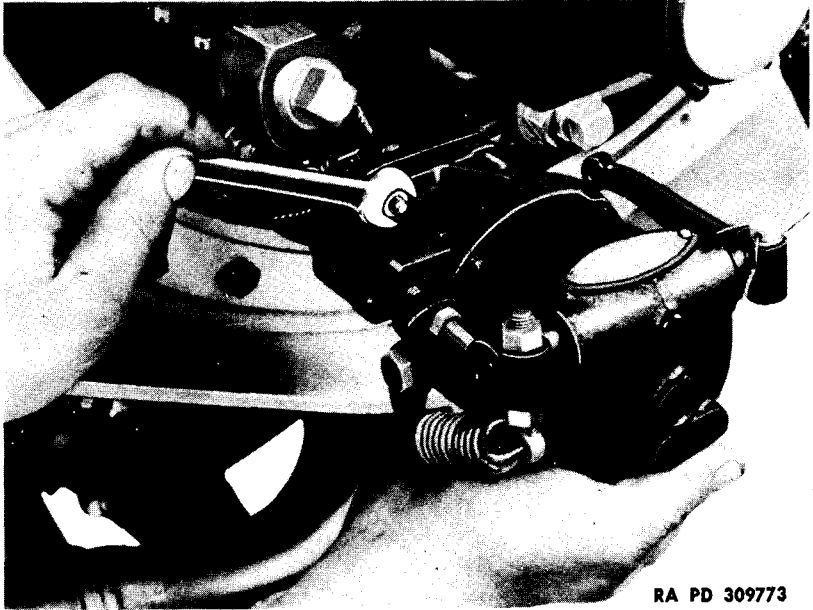

Figure 11 – Removing Generator Flange Nuts

**ORDNANCE MAINTENANCE — 9-CYLINDER, RADIAL, GASOLINE ENGINE
(CONTINENTAL MODEL R975-C1)**

RA PD 309773

Figure 12 — Removing Governor Flange Nuts

covers. Remove nuts and lock washers from the two bolts clamping the distributor block covers, and disengage safety pins and spring clamps at the sides of the magneto. Take distributor block covers off, and lift out the distributor blocks (fig. 13). Do not detach wires from the distributor blocks at this time. Disconnect ground and booster wires by removing thumb screws and allowing the wires to hang loose. Remove lock wire from the mounting flange hold-down nuts, and remove the attaching nuts and flat washers. Support the magneto while removing the last attaching nut. Grasp the magneto and pull straight out to disengage the drive coupling, splines, and remove the unit from the engine. Reinstall distributor block covers on the magnetos, and attach clamping and adapter bolts to prevent misplacement.

h. Remove Three-way Accessory Drive Housing. Detach lock wire, and remove the three outside nuts attaching the housing to the rear section. Take off the auxiliary drive replacement cover located on the right side of the housing, and remove cotter pins from the two nuts on the inside. Remove the nuts, and pull the three-way accessory drive housing off the rear section (fig. 14).

R975-C1 ENGINE (CONTINENTAL)

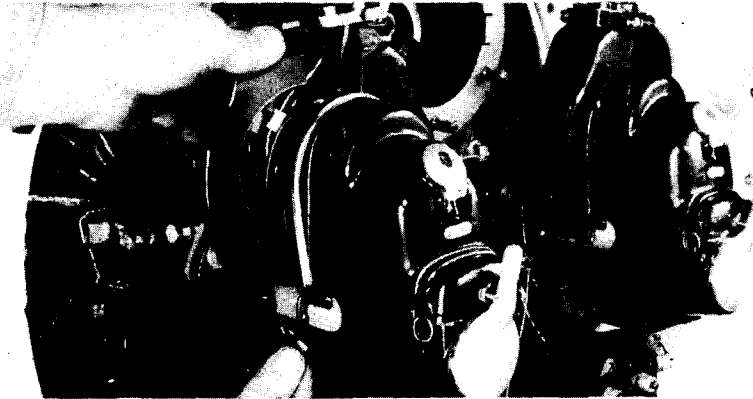

A—REMOVING DISTRIBUTOR BLOCK SHIELD

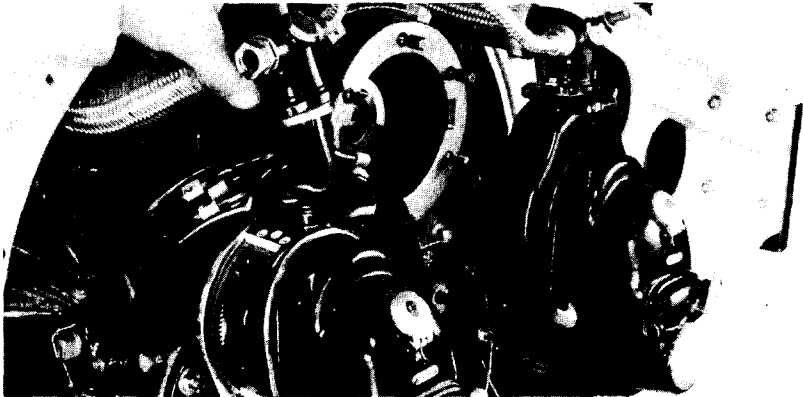

B - REMOVING DISTRIBUTOR BLOCKS

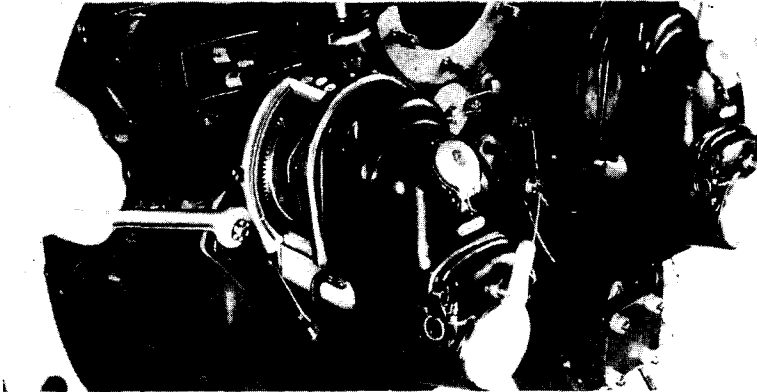

C—REMOVING MAGNETO FLANGE NUTS

RA PD 309779

Figure 13—Removing Distributor Block Shield, Blocks, and Magneto

ORDNANCE MAINTENANCE — 9-CYLINDER, RADIAL, GASOLINE ENGINE
(CONTINENTAL MODEL R975-C1)

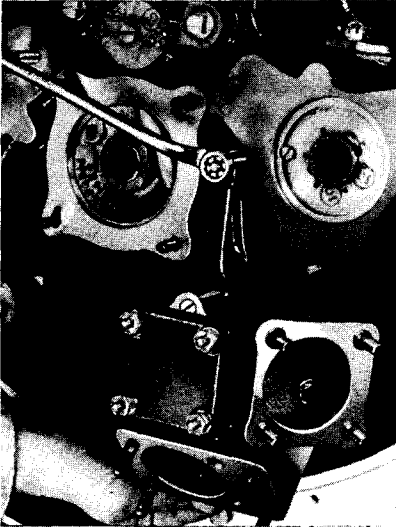

**A—LOOSENING OR TIGHTENING
THREE-WAY ACCESSORY DRIVE
HOUSING NUTS**

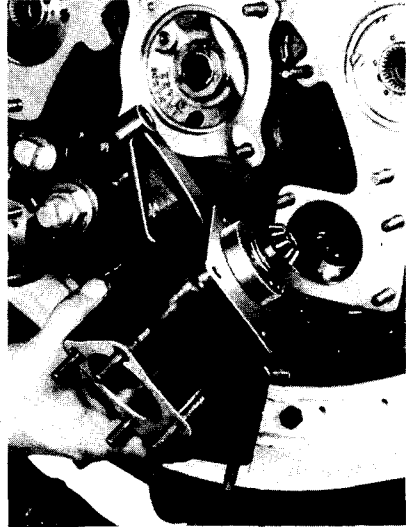

**B—REMOVING OR INSTALLING
THREE-WAY ACCESSORY DRIVE
ASSEMBLY**

RA PD 309782

Figure 14 — Removing Three-way Accessory Drive Assembly

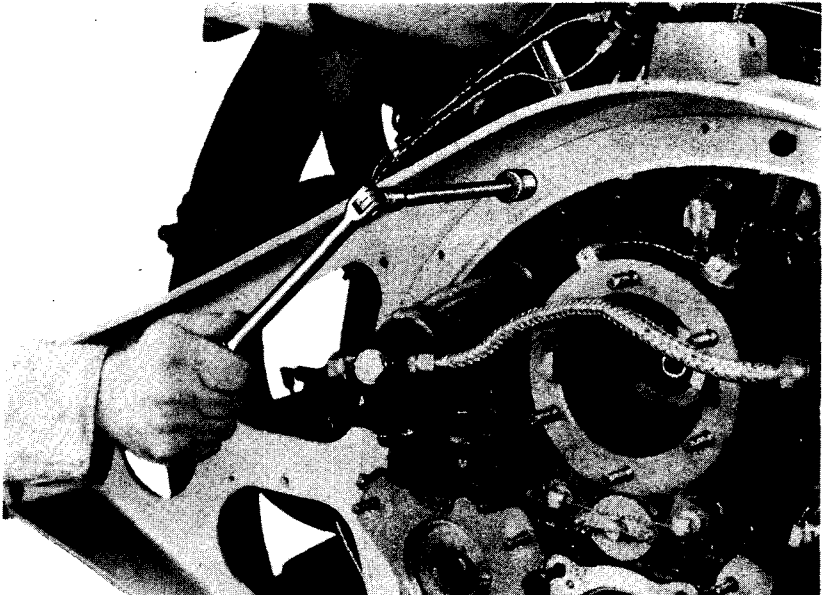

RA PD 309783

Figure 15 — Removing Engine Support Beam

R975-C1 ENGINE (CONTINENTAL)

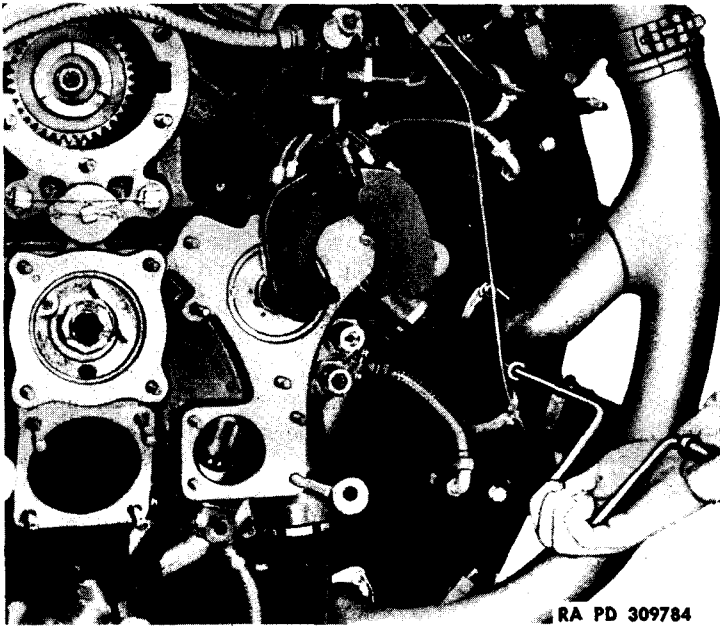

Figure 16 — Removing Exhaust Manifolds

i. **Remove Engine Support Beam.** Attach lifting sling (41-S-3832) to the rocker arm hub bolt nut on the exhaust valve rocker arm of No. 9 cylinder and the intake rocker arm hub bolt of No. 2 cylinder. Support the engine with a chain hoist, and remove cotter pins from each of the nine castellated nuts holding engine support beam to crankcase rear section. Remove nuts and washers from bolts, and pull bolts out of the rear case mounting lugs (fig. 15). **NOTE:** Support the beam while removing the last bolts.

j. **Remove Exhaust Manifolds.** Disconnect lock wire, remove attaching nuts, and take off the manifolds (fig. 16).

k. **Install On Overhaul Stand.** Securely bolt the engine to the bed plate of an overhaul stand in preparation for further disassembly. Fasten the engine by inserting bolts through the regular engine mounting bolt holes.

l. **Remove Flywheel Hub Retaining Nut.** Turn the overhaul stand so that the engine will be in a horizontal position, with the splined end of the crankshaft pointing upward. Remove the cotter pin from the retaining nut locking pin and drive out the pin, using a small brass drift and a hammer if necessary. Place a $\frac{3}{4}$ -inch round bar through the large holes provided in the hub of retaining nut, and break loose by striking the bar with a hammer. Back the nut off, and

**ORDNANCE MAINTENANCE — 9-CYLINDER, RADIAL, GASOLINE ENGINE
(CONTINENTAL MODEL R975-C1)**

¾ IN. ROUND BAR

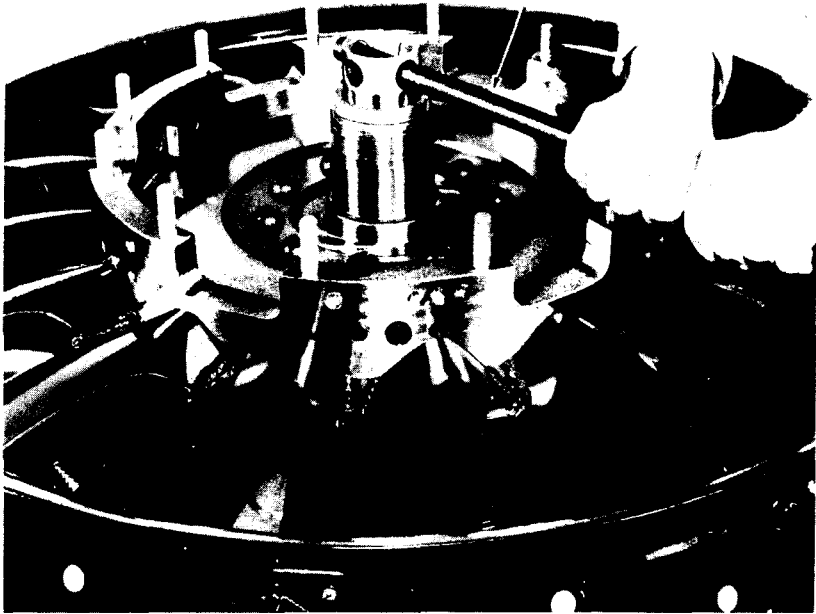

Figure 17 — Removing Flywheel Hub Nut

RA PD 309774

remove it together with the two halves of the steel flywheel hub front cone (fig. 17).

m. Remove Hub, Flywheel, and Fan. Screw the lifting eye on the flywheel hub, attach to a chain hoist, and lift off the flywheel and fan assembly (fig. 18). Care will be used to prevent damage to threads at the end of the crankshaft. Spread the gap on flywheel rear cone with a small screw driver, if necessary, and lift the cone off the crankshaft (fig. 19).

n. Remove Engine Support Tube. Remove lock wire from the 10 front engine support cap nuts and loosen the nuts slightly. The engine support tube will then be removed by sliding out through the cowl.

o. Remove Cowl. Disengage the toothed fasteners which secure the intercylinder and cylinder head air deflectors to the cowl (fig. 20). Remove nuts and bolts which hold the cowl to bosses on the front of the rocker boxes (fig. 21). Lift cowl off the engine.

p. Remove Priming Distributor and Lines. Disconnect union nuts from the priming tube fittings on the intake pipes (fig. 22). Remove nuts, washers, bolts, and clamps, attaching priming tubes and distributor to intake pipe. Remove the priming tubes and dis-

R975-C1 ENGINE (CONTINENTAL)

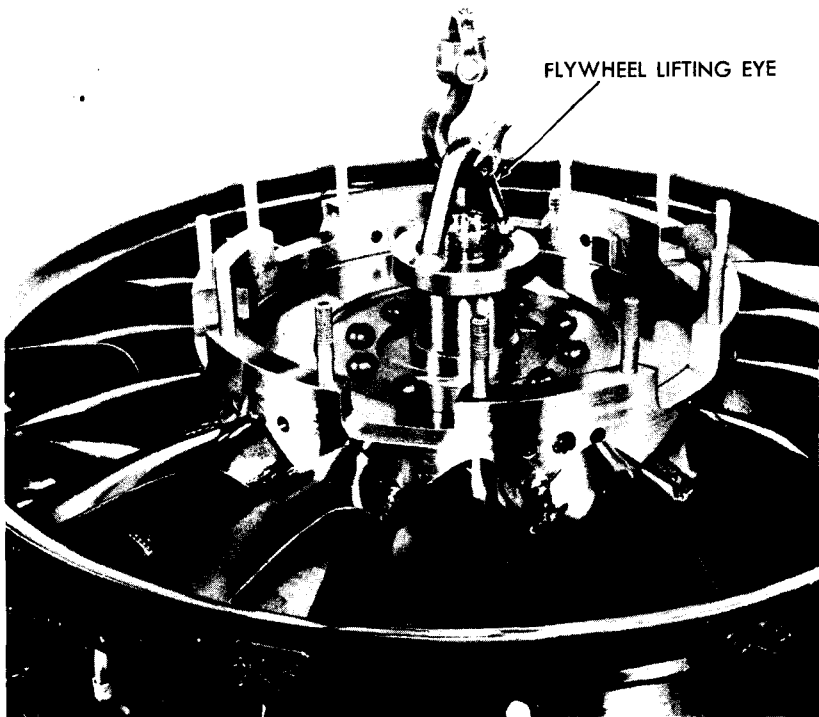

RA PD 309775

Figure 18 – Lifting Off Flywheel

tributor. Tag all priming tubes to insure installation in their original positions during engine reassembly. Place the priming lines in a parts bin where they will not be bent or damaged in any way.

7. DISASSEMBLY.

a. **Remove Tachometer Drive.** Detach lock wire and remove the three attaching nuts, using the lug wrench (41-W-3418). If tachometer drive assembly does not remove freely, tap lightly with a rawhide hammer to free it from crankcase rear section (fig. 23).

b. **Remove Main Oil Pump.** Remove lock wire and cotter pins from the eight flange retaining nuts, and, with the lug wrench (41-W-3418), remove nuts on the front and right sides of the pump. Remove other nuts with the box end wrench (41-W-1577-500). Support the pump with one hand while removing the last nut (fig. 24).

c. **Remove Atmospheric Breather.** Disconnect hose clamps at the crankcase main and rear sections and the supporting bracket at

ORDNANCE MAINTENANCE — 9-CYLINDER, RADIAL, GASOLINE ENGINE
(CONTINENTAL MODEL R975-C1)

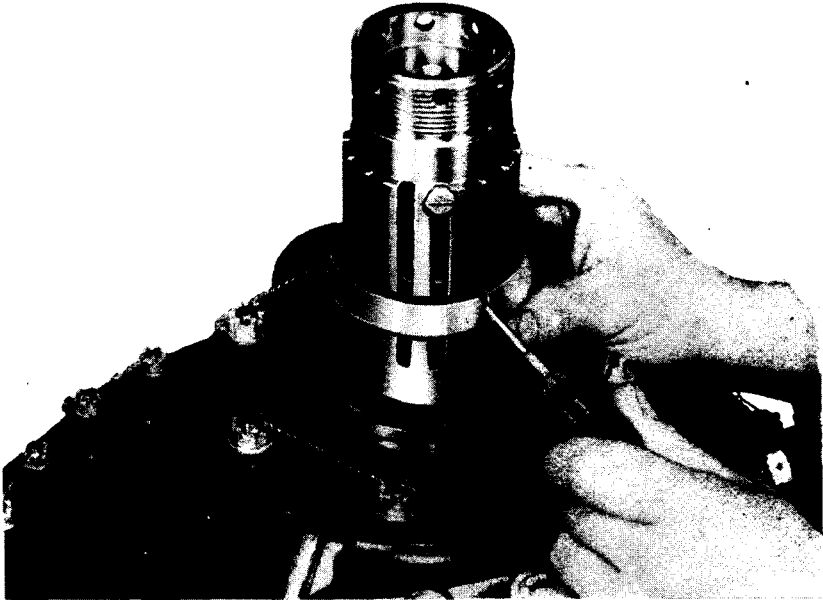

RA PD 309776

Figure 19 — Removing Flywheel Hub Rear Cone

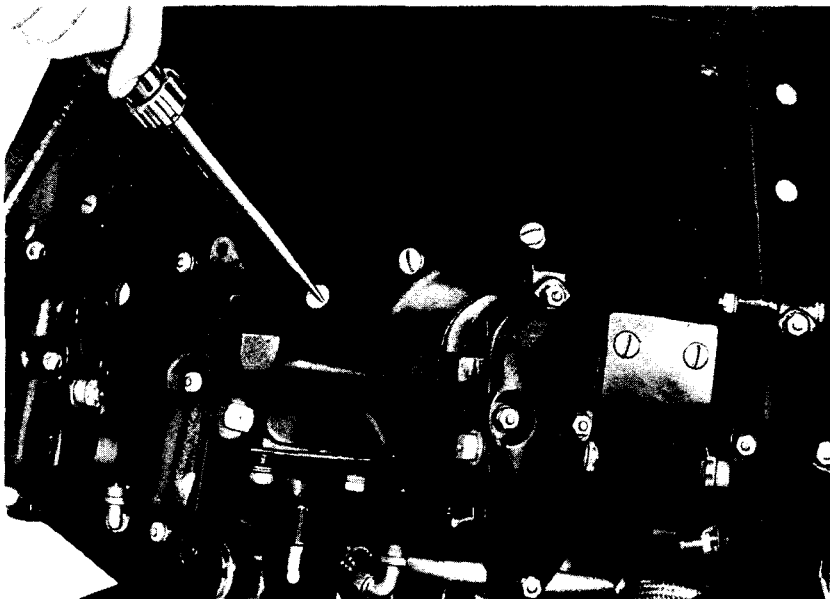

RA PD 309789

*Figure 20 — Removing Cylinder Head and Intercylinder Air Deflector
Screws From Cowl*

R975-C1 ENGINE (CONTINENTAL)

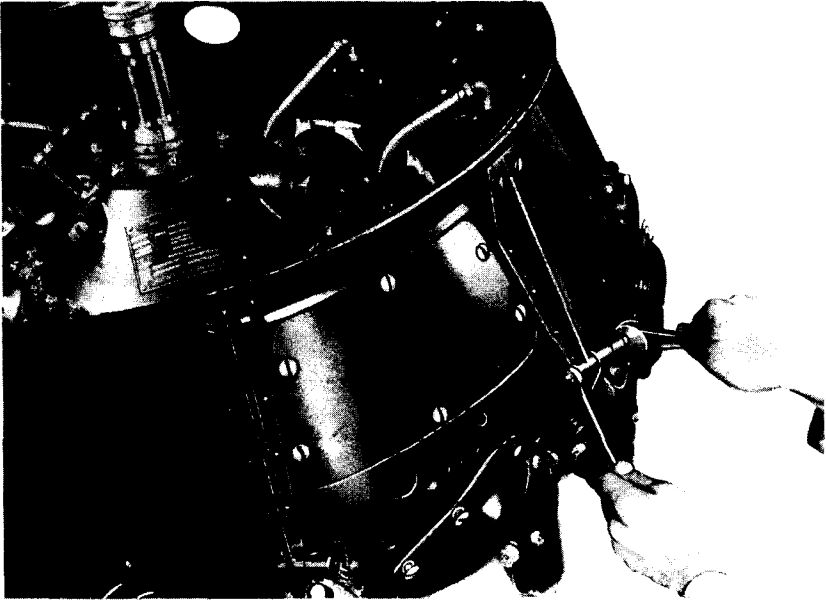

RA PD 309790

Figure 21 — Removing Nut and Bolt From Cowl Attaching Boss

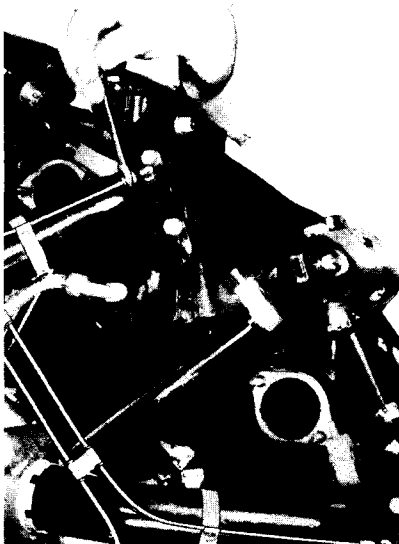

A — DISCONNECTING PRIMER LINES

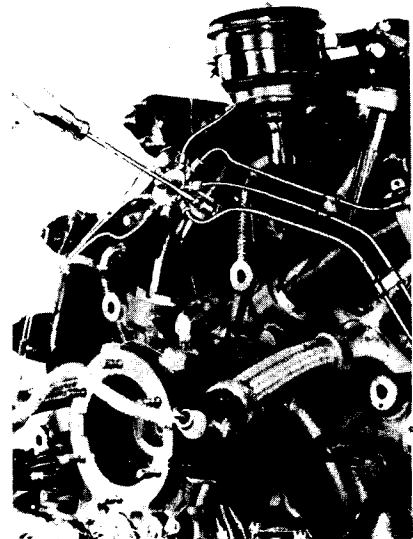

B — DISCONNECTING PRIMER DISTRIBUTOR

RA PD 309785

Figure 22 — Removing Priming System

ORDNANCE MAINTENANCE — 9-CYLINDER, RADIAL, GASOLINE ENGINE
(CONTINENTAL MODEL R975-C1)

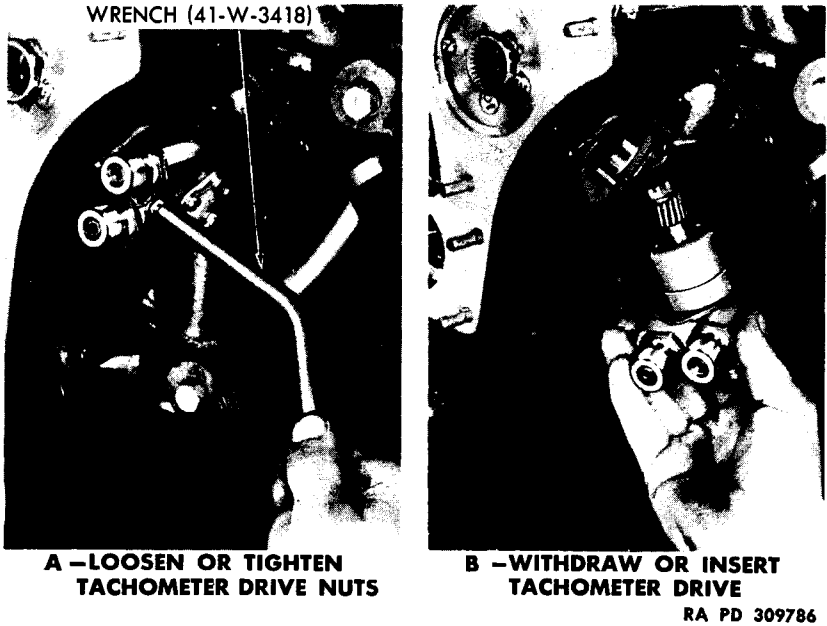

Figure 23 — Removing Tachometer Drive

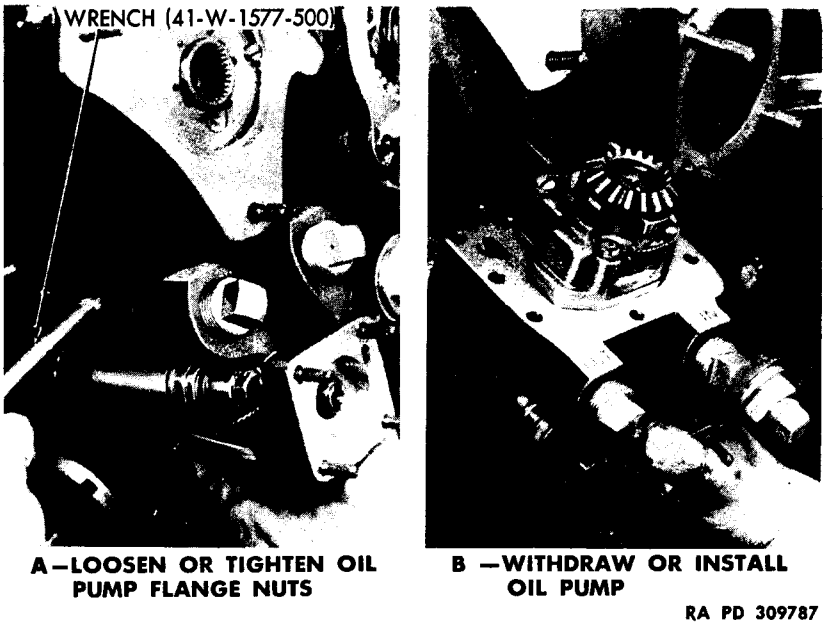

Figure 24 — Removing Oil Pump Assembly

R975-C1 ENGINE (CONTINENTAL)

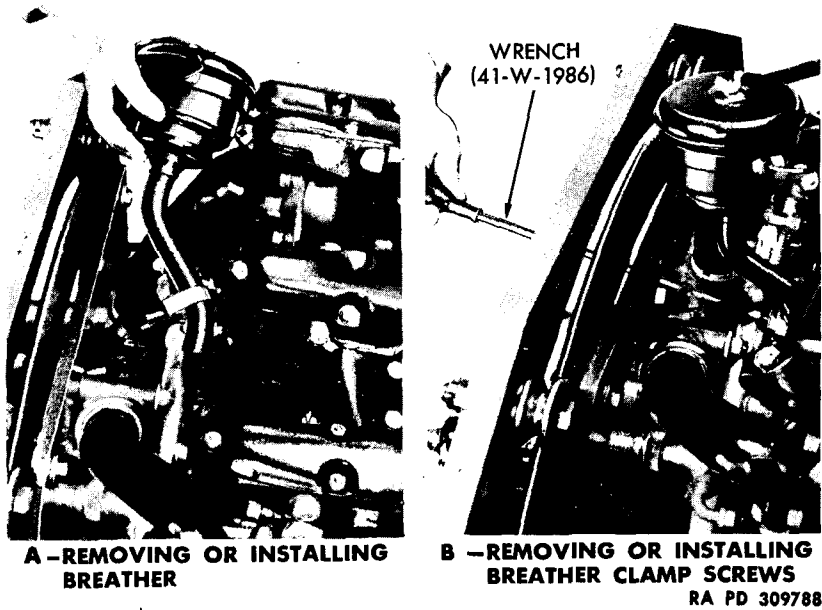

Figure 25 - Removing Atmospheric Breather

the cylinder head rocker box (fig. 25). When removing the breather, loosen the upper hose clamp only at the crankcase fitting. The hose, together with the other clamp, can be more easily removed after removing the cylinders. Use the hose clamp wrench (41-W-1986) to loosen hose clamp screws.

d. Remove Spark Plugs. Loosen elbow to conduit nuts. Loosen the terminal elbow coupling nuts and withdraw the elbows (fig. 26). Remove spark plugs with the socket wrench (41-W-3328), and install protectors (dummy plugs) to terminal elbow coupling nuts (fig. 26). Remove front spark plugs with the engine in the front-end-up position. Rotate the overhaul stand to the front-end-down position before removing the rear spark plugs.

e. Remove Rocker Box Covers. Remove nuts, lock washers, and flat washers from the four rocker box cover studs, and lift the covers off (fig. 27).

f. Remove Rocker Arms and Push Rods. Remove cotter pins from the intake and exhaust rocker arm hub bolt nuts. Holding the head of the hub bolt with a wrench, remove the nut from the other end. Turn crankshaft until there is clearance between the rocker roller and the valve stem. Push out the hub bolt, being careful not

**ORDNANCE MAINTENANCE — 9-CYLINDER, RADIAL, GASOLINE ENGINE
(CONTINENTAL MODEL R975-C1)**

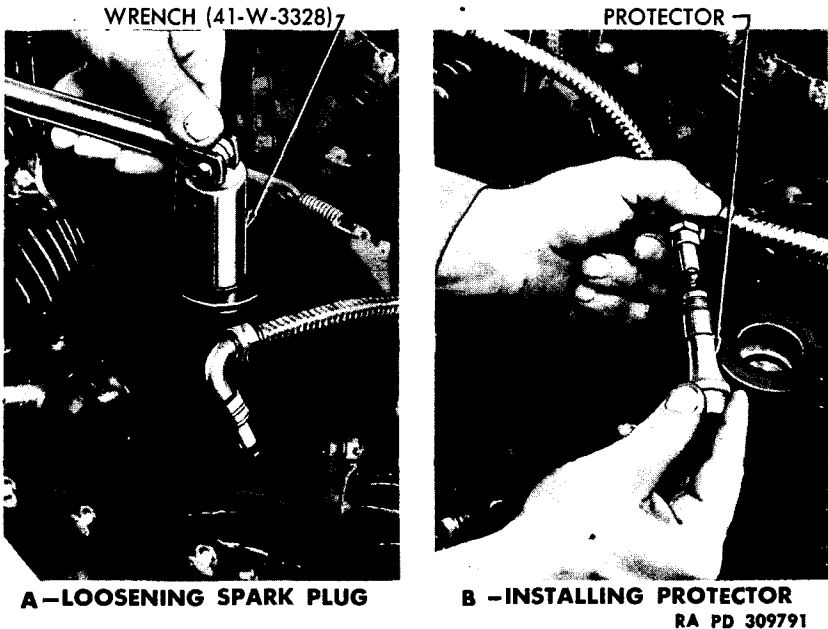

Figure 26 — Removing Spark Plug and Installing Protector

to damage the threads on the bolt or the bolt holes in the rocker box (fig. 27). Remove the thrust washer. Remove the rocker arm and push rod. Place rocker arms, bolts, nuts, and push rods in a box having 18 individual compartments to facilitate proper re-assembly.

g. Remove Cylinder Head Air Deflectors. Remove cap screws from the intake pipe flanges and remove the deflectors (fig. 28).

h. Remove Push Rod Housings. Loosen clamps at each end of the push rod housing, using the hose clamp wrench (41-W-1986). Loosen only the inner clamp at the crankcase end of the housing. Slide the hose on the rocker box end down until it rests completely on the push rod housing. Twist the housing to the side a little, and pull off the engine (fig. 29).

i. Remove Valve Tappet Sockets. Remove all valve tappet ball sockets and springs. Place a small quantity of heavy grease on the end of a push rod and stick in the valve tappet socket to remove the socket (fig. 30). Place the ball sockets and springs in a box having 18 individual compartments numbered to facilitate assembly in the same location.

R975-C1 ENGINE (CONTINENTAL)

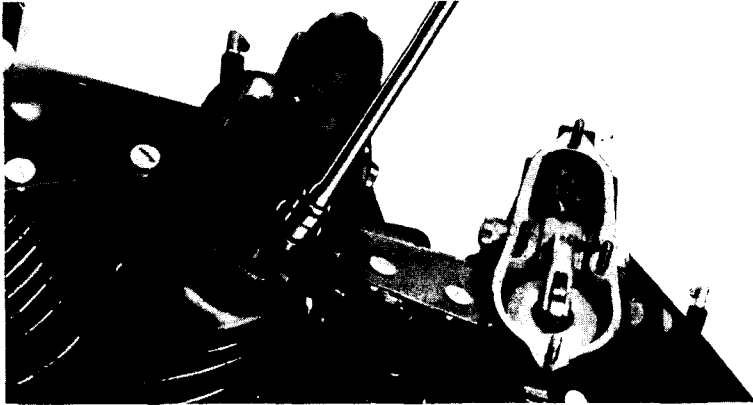

A - LOOSENING ROCKER BOX COVER NUTS

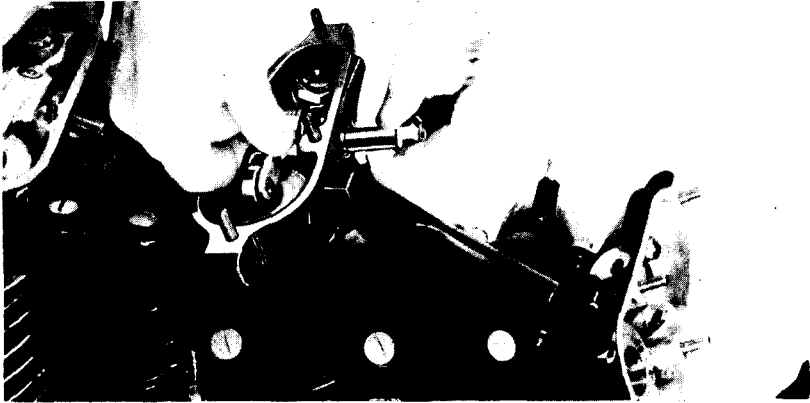

B - REMOVING OR INSTALLING ROCKER ARM AND BOLTS



C - WITHDRAWING PUSH ROD

RA PD 309792

Figure 27 - Removing Rocker Box Cover, Rocker Arm, and Push Rod

**ORDNANCE MAINTENANCE — 9-CYLINDER, RADIAL, GASOLINE ENGINE
(CONTINENTAL MODEL R975-C1)**

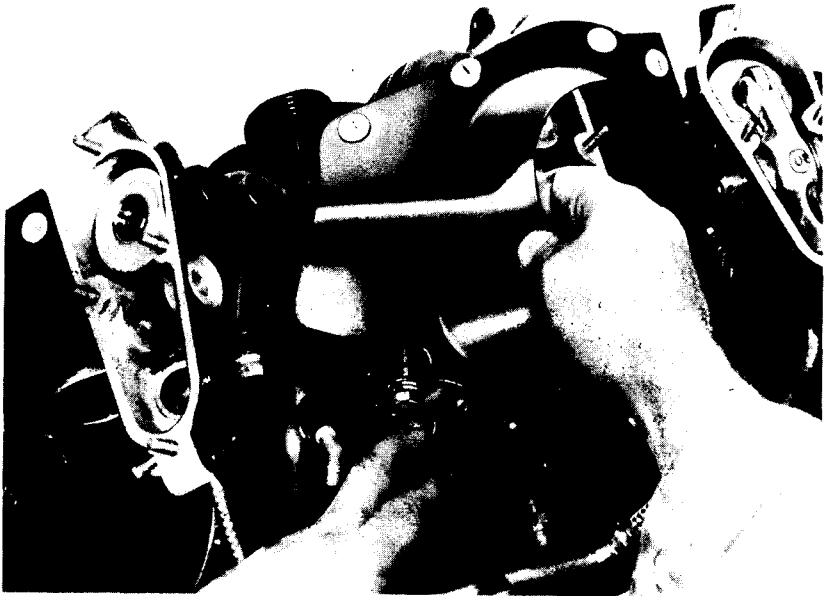

RA PD 309795

Figure 28 — Removing Cylinder Head Air Deflector



RA PD 309796

Figure 29 — Removing Push Rod Housing

R975-C1 ENGINE (CONTINENTAL)

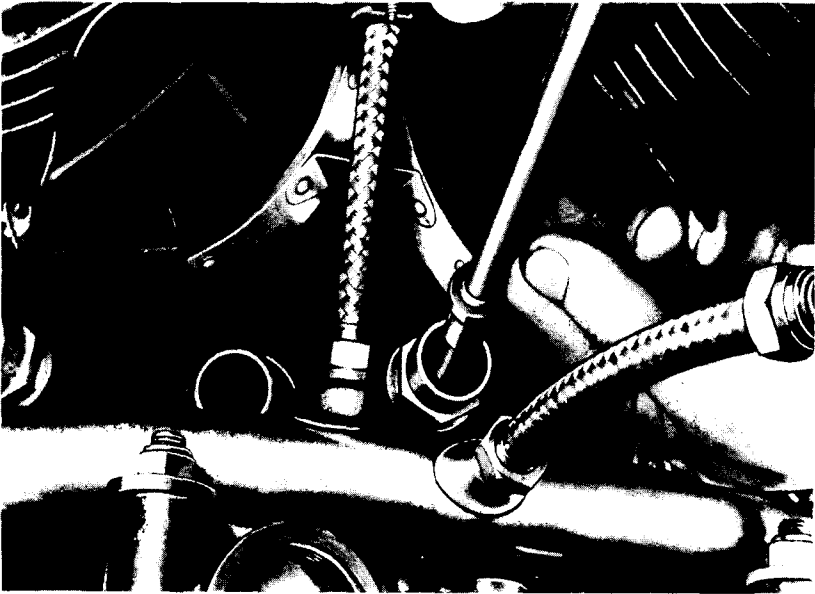

RA PD 309797

Figure 30 – Removing Valve Tappet Ball Socket and Spring

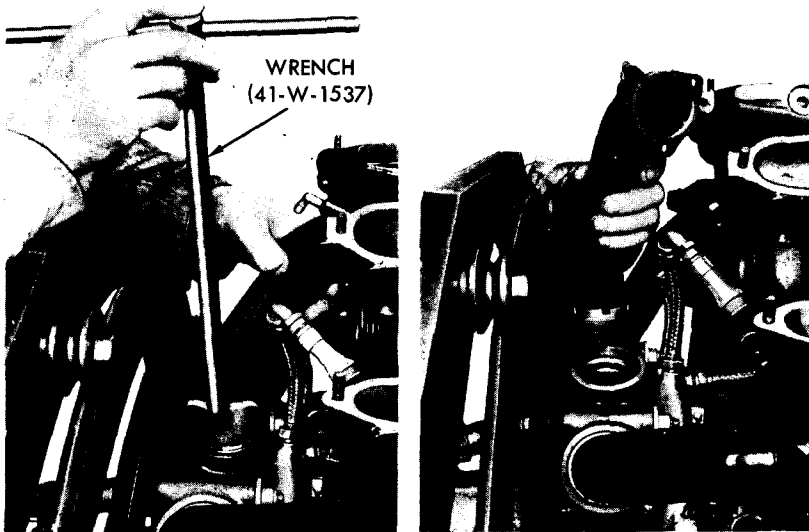

**A – LOOSENING INTAKE PIPE
PACKING NUT**

B – LIFTING INTAKE PIPE OUT
RA PD 309794

Figure 31 – Removing Intake Pipe

ORDNANCE MAINTENANCE — 9-CYLINDER, RADIAL, GASOLINE ENGINE
(CONTINENTAL MODEL R975-C1)

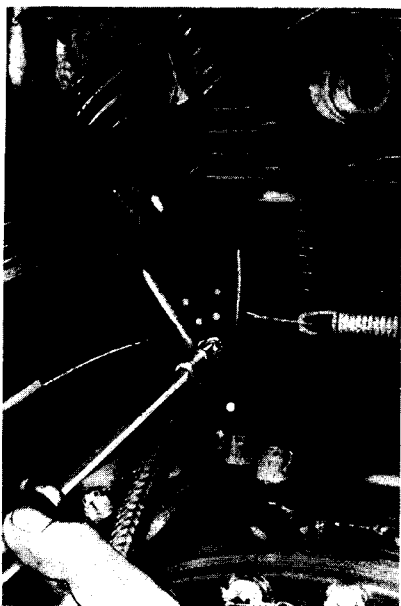

**A — REMOVE DEFLECTOR DISK
SCREWS**

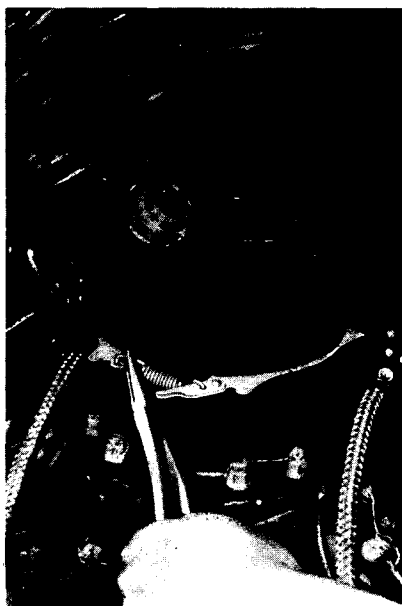

**B — DISCONNECTING DEFLECTOR
CLAMP SPRING**



**C — WITHDRAWING SPARK PLUG
WIRE CONDUIT**

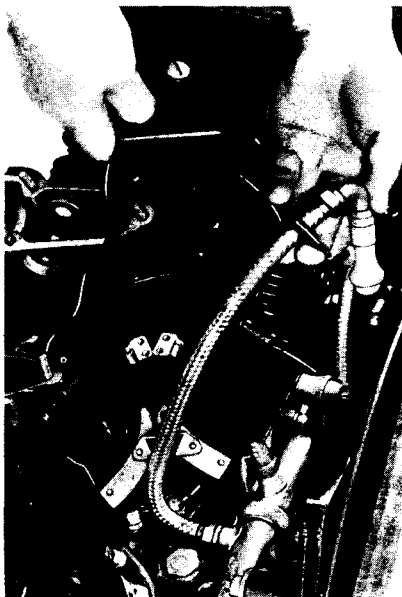

D — LIFTING DEFLECTOR OUT

RA PD 309798

Figure 32 — Removing Intercylinder Air Deflector

R975-C1 ENGINE (CONTINENTAL)

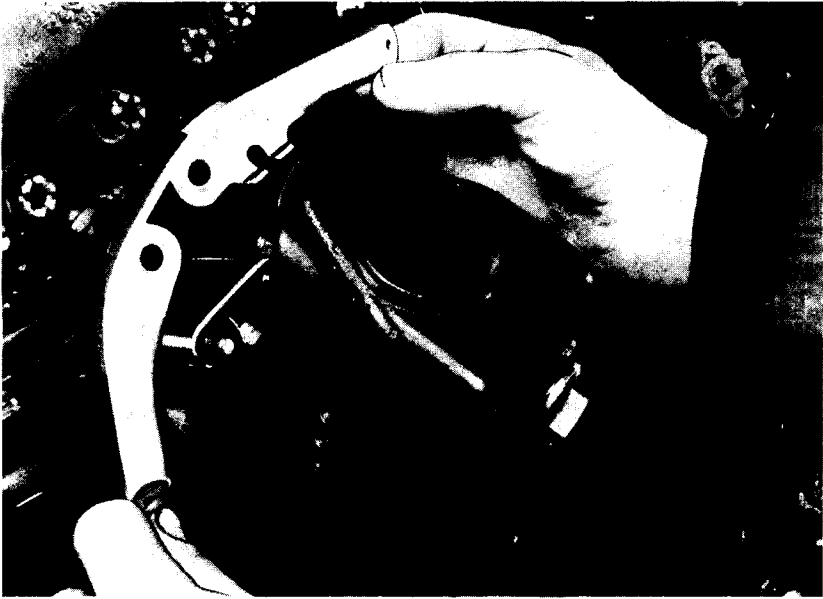

RA PD 309803

Figure 33 – Removing Cylinder Air Deflector Brace

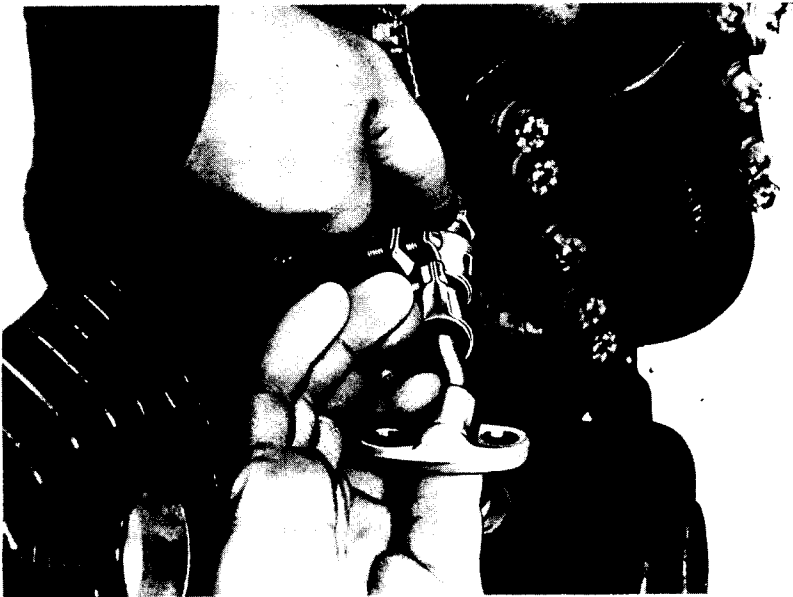

RA PD 309801

Figure 34 – Removing Oil Sump External Tube

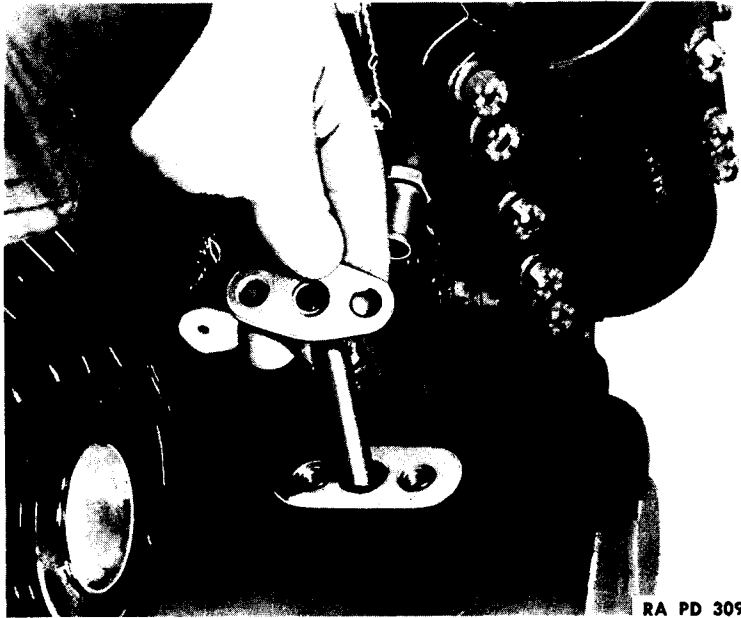
**ORDNANCE MAINTENANCE — 9-CYLINDER, RADIAL, GASOLINE ENGINE
(CONTINENTAL MODEL R975-C1)**

RA PD 309802

Figure 35 — Removing Oil Sump Internal Tube

j. Remove Intake Pipes. Loosen the packing nut at the crankcase end of all intake pipes, using the lug wrench (41-W-1537). Remove the two remaining cap screws from the intake pipe flange. Pull the flange back from the intake port, and withdraw the intake pipes (fig. 31).

k. Remove Intercylinder Air Deflectors. Remove the two screws that fasten each spark plug ignition wire conduit disk and grommet to the air deflectors, and withdraw the ignition wire conduits (fig. 32). Disengage the springs that retain the air deflector clamps, and unhook clamps from the deflectors. Remove nuts from the oil sump front attaching studs, and take off the bracket to remove the air deflector between cylinders Nos. 5 and 6 (fig. 33).

l. Remove Front Oil Sump Tubes. Loosen clamps on the front oil drain tube hose connection, and slide the hose down on the sump tube. Remove cap screws holding the tubes, and lift off the external tube, together with the hose connection and clamps (fig. 34). Take out the internal tube (fig. 35). If the internal tube is stuck, loosen by lightly tapping the flange with a fiber hammer. **CAUTION: Do not pry off with a screwdriver.**

R975-C1 ENGINE (CONTINENTAL)

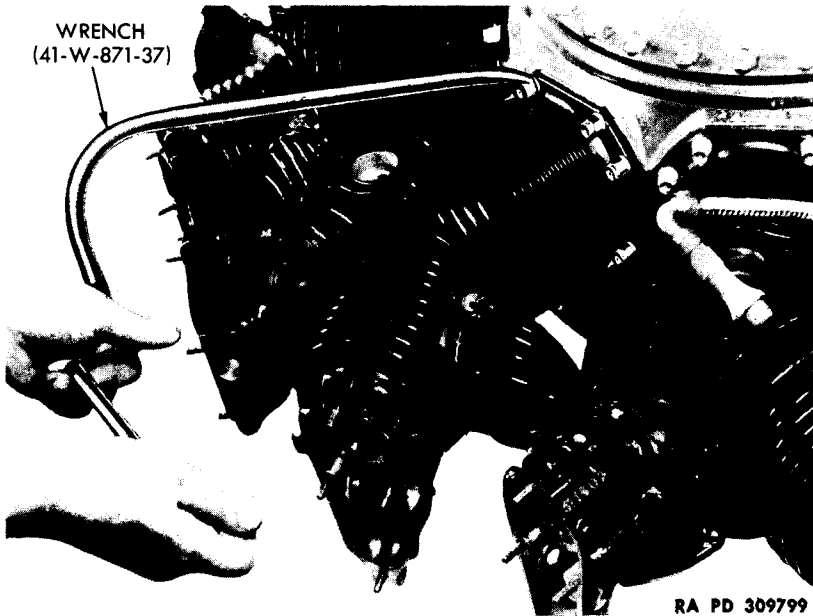
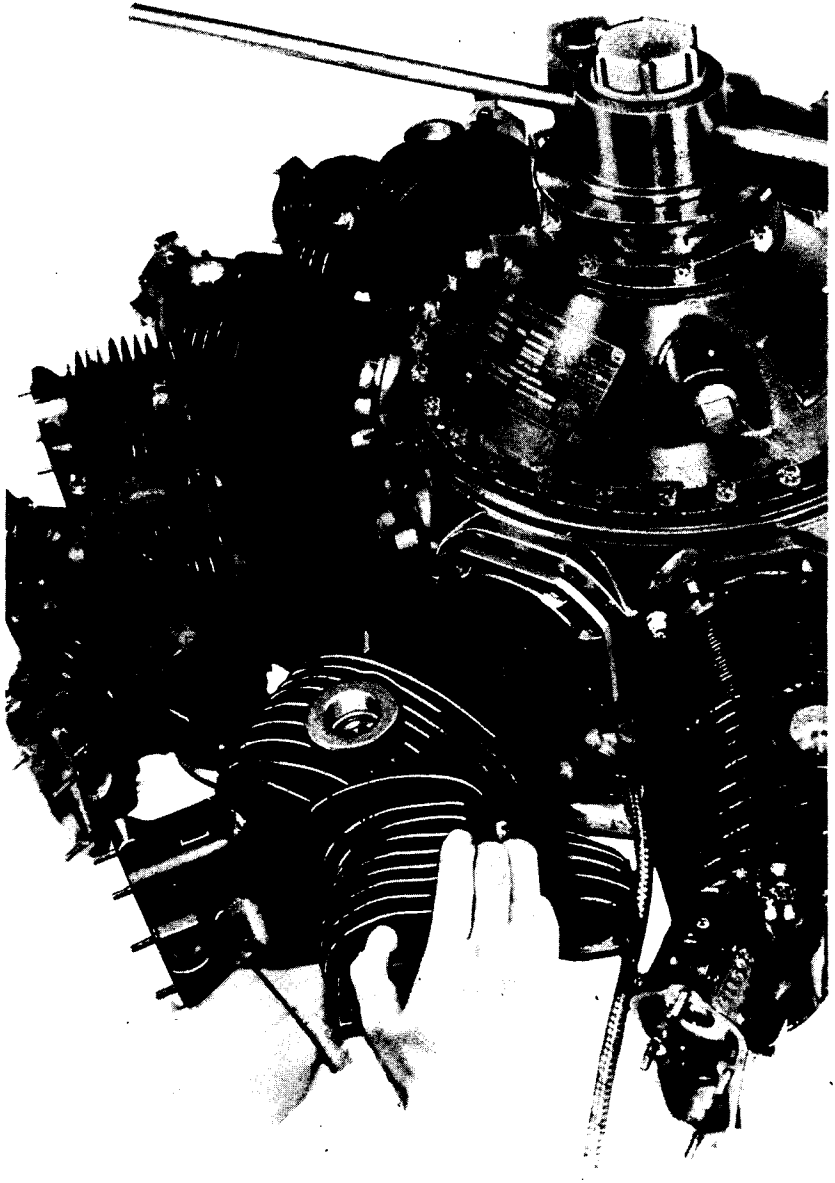

Figure 36 — Removing Cylinder Flange Nuts

m. **Remove Cylinders.** Begin removal of cylinders with No. 2 cylinder and continue on around, leaving the No. 1, or master rod, cylinder until the last. Remove lock wire from the hold-down nuts of the cylinder to be taken off, and bring the crankshaft around until the piston for that cylinder is approximately at top center. Loosen the hold-down nuts (fig. 36) with the wrench (41-W-871-37), and remove from the studs. Grasp the cylinder firmly and pull straight out (fig. 37). If the cylinder is difficult to move or get started, it may be rocked from side to side in a horizontal plane until it loosens. Place the cylinder in an appropriate carrier to protect it from damage.

n. **Remove Piston Pins and Pistons.** Remove piston pin retainers from each boss in the piston, and withdraw the pin (fig. 38). If the pins are sticking, use the fiber drift (41-D-1541-75) and a rawhide hammer to drive out. When using a drift, lift the weight of the piston off the end of the connecting rod while striking the drift. Use care when driving the pin out as it is liable to loosen suddenly and be damaged by falling. Lift the piston off the connecting rod as soon as the pin clears the connecting rod bushing. Place a connecting rod protecting plate over a pair of cylinder hold-down studs and secure with two cylinder hold-down nuts.

ORDNANCE MAINTENANCE — 9-CYLINDER, RADIAL, GASOLINE ENGINE
(CONTINENTAL MODEL R975-C1)



RA PD 309800

Figure 37 — Removing Cylinder

R975-C1 ENGINE (CONTINENTAL)

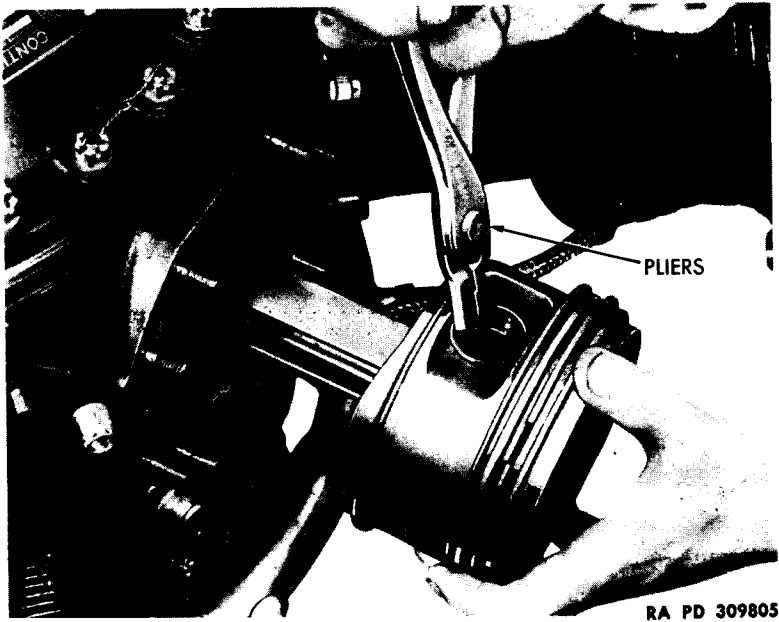

Figure 38 — Removing Piston Pin Retainer

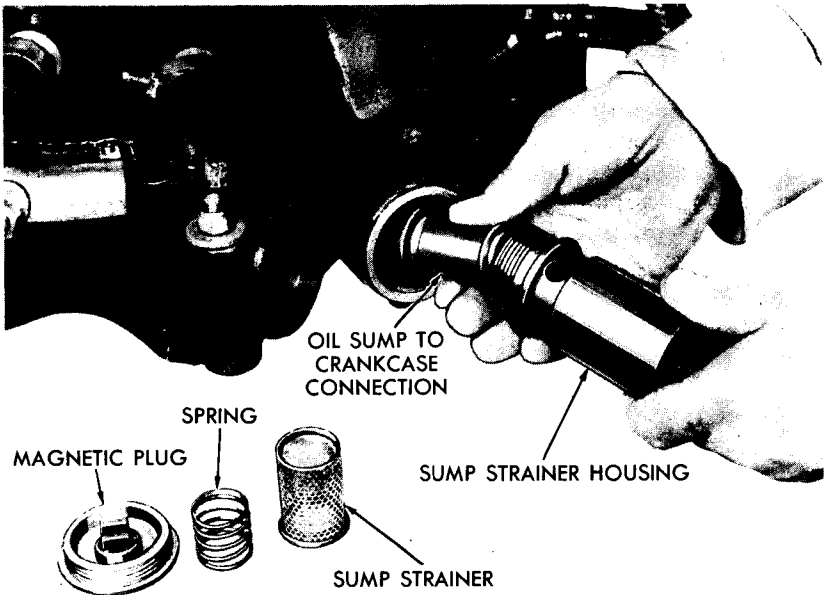

Figure 39 — Removing Oil Sump Strainer Assembly

**ORDNANCE MAINTENANCE – 9-CYLINDER, RADIAL, GASOLINE ENGINE
(CONTINENTAL MODEL R975-C1)**



RA PD 309806

Figure 40 – Removing Ignition Harness Retaining Nuts

R975-C1 ENGINE (CONTINENTAL)

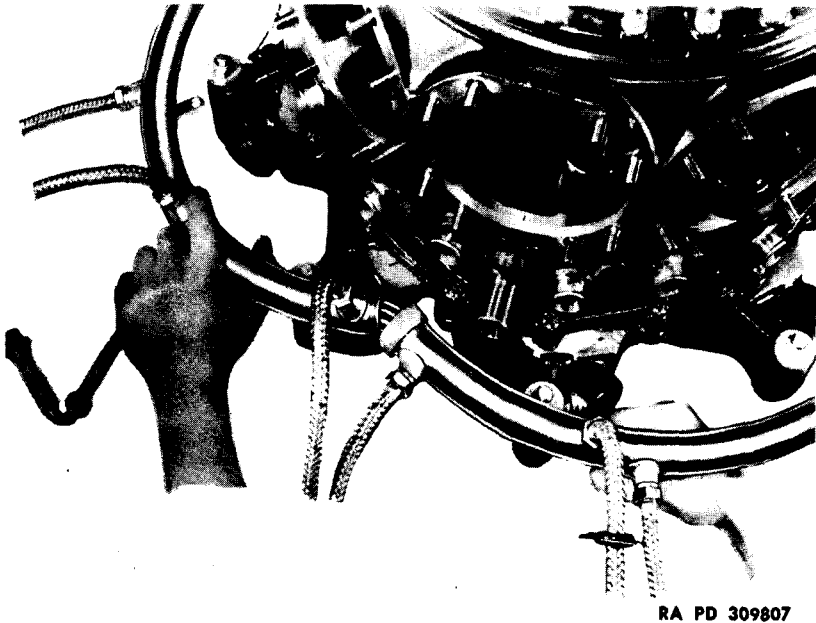

Figure 41 – Lifting Off Ignition Harness

o. Remove Oil Sump. Unscrew and remove the hexagon plug from the bottom rear portion of the sump. Lift out the strainer spring and strainer. Remove lock wire, and unscrew the strainer housing which secures the sump to the crankcase main section, using wrench (41-W-906-12). Lift out the connector which joins the oil passage in the crankcase main section to the strainer housing (fig. 39). Lift off the sump and adaptor as a unit.

p. Remove Ignition Wiring Harness. Remove the four nuts securing the ignition wiring harness to the crankcase main section parting flange (fig. 40). Separate the main conduit halves, and remove the harness assembly from the engine (fig. 41). Avoid striking distributor blocks against engine.

q. Remove Front Section Cover. Place the crankshaft thrust bearing nut lug wrench (41-W-871-35) over crankshaft thrust bearing nut, and install the timing fixture (41-F-2997-84) to hold the crankshaft from turning. Loosen nut by striking heavily on the end of the wrench with a lead hammer while holding the timing adapter handle (fig. 42). Remove the nut from the crankshaft. Remove lock wire, nuts, and washers, and remove the front cover. If necessary, loosen the cover by striking lightly with a fiber hammer.

ORDNANCE MAINTENANCE — 9-CYLINDER, RADIAL, GASOLINE ENGINE
(CONTINENTAL MODEL R975-C1)

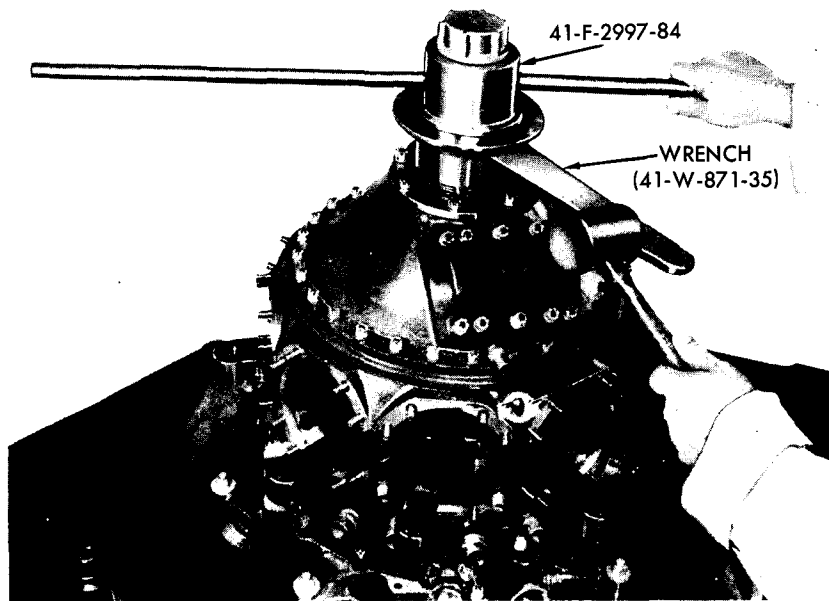

RA PD 309808

Figure 42 — Loosening Crankshaft Thrust Bearing Nut

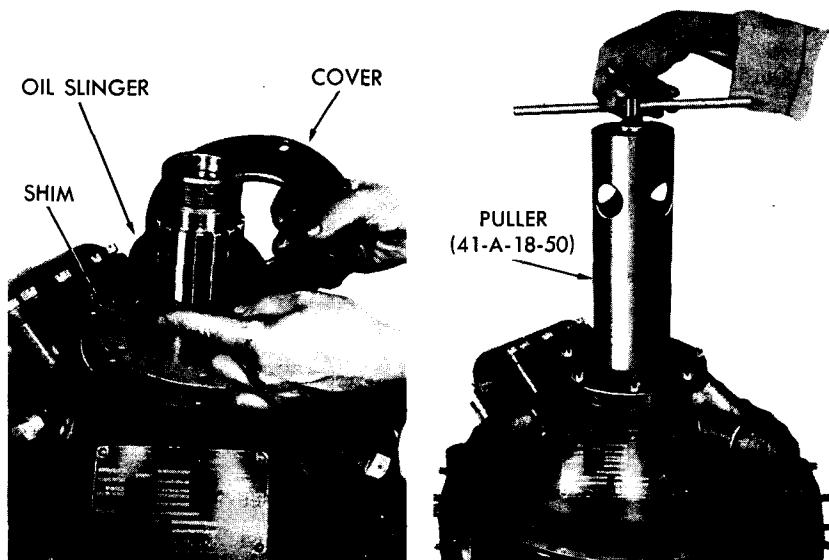

A—REMOVING OR INSTALLING
COVER SHIM AND OIL SLINGER

B—PULLING FRONT SECTION

RA PD 309809

Figure 43 — Removing Crankcase Front Section Cover, Shim, Oil Slinger, and Housing

R975-C1 ENGINE (CONTINENTAL)

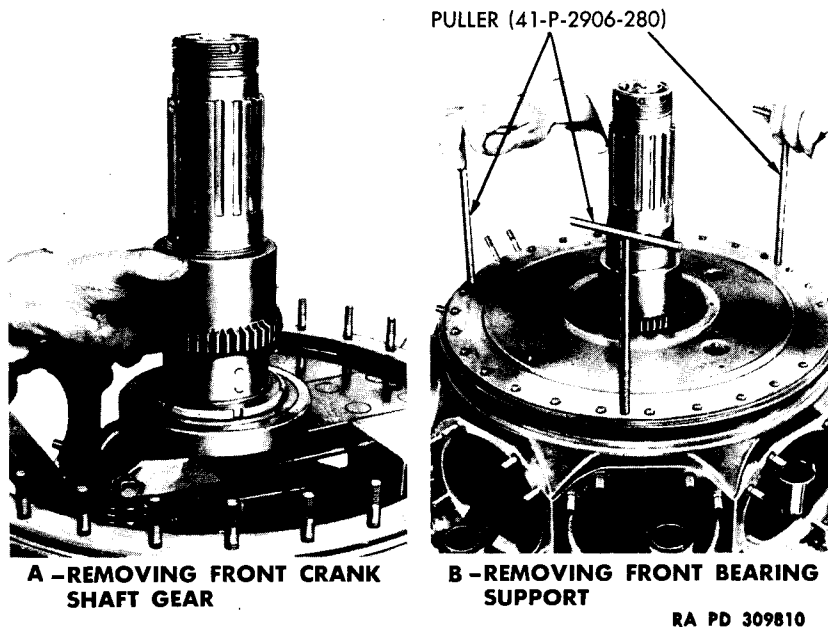

Figure 44 – Removing Front Main Bearing Support and Crankshaft Gear

CAUTION: Do not use a tool to pry between the cover and the front section. Remove the oil slinger and the cover shim (fig. 43).

r. **Remove Crankcase Front Section.** Detach lock wire, and remove the nuts and washers. Install the crankcase front section puller adapter (41-A-18-50) and secure to the front cover flange with seven nuts (fig. 43). Turn down on the handle of the puller until the front section is free, and lift off the entire assembly.

s. **Remove Front Main Bearing Support.** Insert pullers (41-P-2906-280) in the three tapped holes provided for removal of the support. Turn pullers down one or two turns at a time, following in order, to lift the support parallel to the crankcase main section (fig. 44). As soon as the cover is free, lift it off.

t. **Remove Front Crankshaft Gear.** Lift the front crankshaft gear off the crankshaft (fig. 44). Remove the gear key set in the crankshaft, and place in a box for safekeeping.

u. **Remove Crankcase Main Section.** Detach lock wire, and remove the nuts and washers from the crankcase main to rear section

ORDNANCE MAINTENANCE — 9-CYLINDER, RADIAL, GASOLINE ENGINE
(CONTINENTAL MODEL R975-C1)

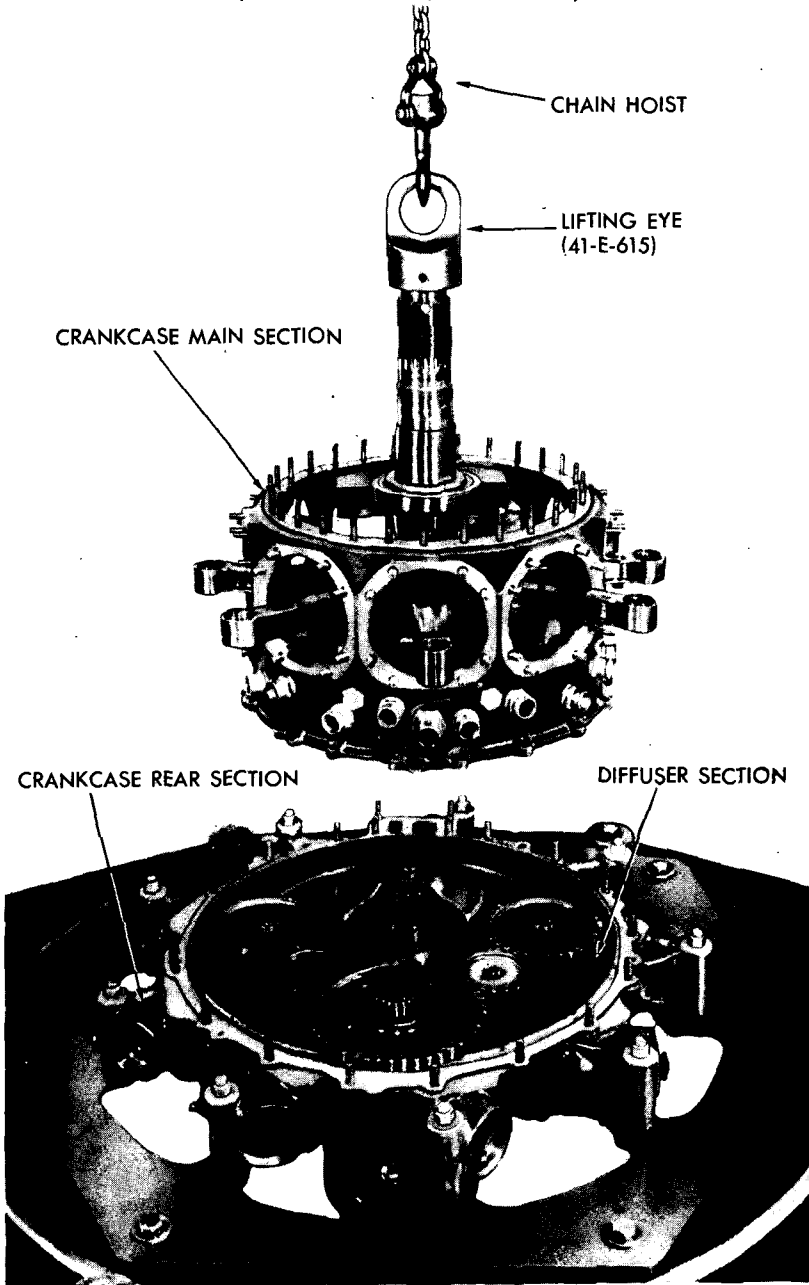

RA PD 309762

Figure 45 — Raising Crankcase Main Section From Diffuser and Rear Sections

R975-C1 ENGINE (CONTINENTAL)

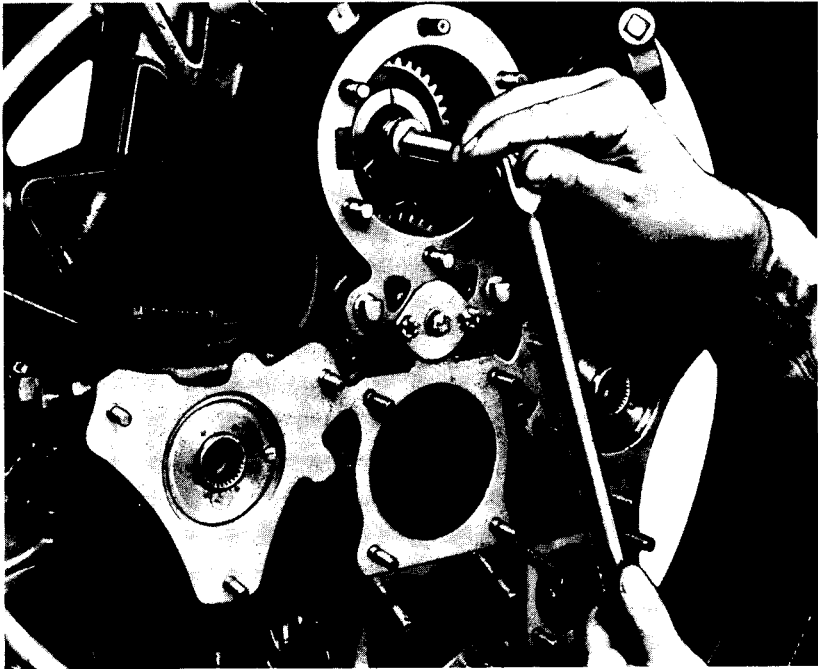

RA PD 309768

Figure 46 – Removing Cranking Motor Shaft Nut

studs. Install the lifting eye (41-E-615) on the front end of the crankshaft, and attach a chain hoist, removing the crankshaft together with the crankcase main section as a unit (fig. 45). To prevent damage raise the chain hoist slowly, at the same time tapping lightly on the rear section at the mounting lugs with a fiber hammer to assist in separation of the parts. When clear of the diffuser section, remove the main section.

v. **Remove Cranking Motor Drive Gear and Cranking Motor Shaft.** The diffuser section is secured to the crankcase rear section by means of three nuts tightened on studs mounted in the rear section. These nuts are obscured by gears that must be removed before the diffuser section can be lifted. To remove the cranking motor gear and shaft, take out the cotter pin, and back the nut off the cranking motor shaft bolt (fig. 46). To prevent the cranking motor shaft from turning with the nut, place a piece of fiber between the teeth of the cranking motor drive gear and an accessory drive idler gear.

ORDNANCE MAINTENANCE — 9-CYLINDER, RADIAL, GASOLINE ENGINE
(CONTINENTAL MODEL R975-C1)

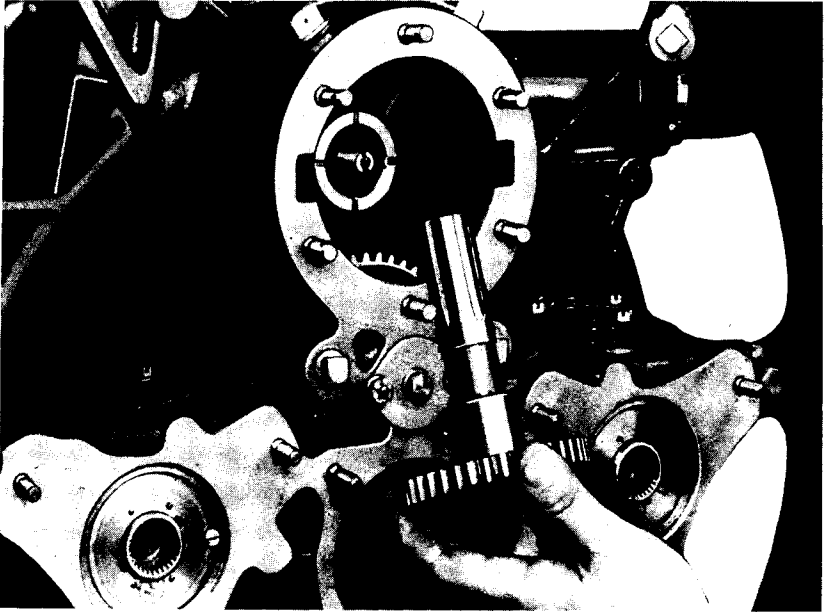

RA PD 309769

Figure 47 — Removing Cranking Motor Shaft

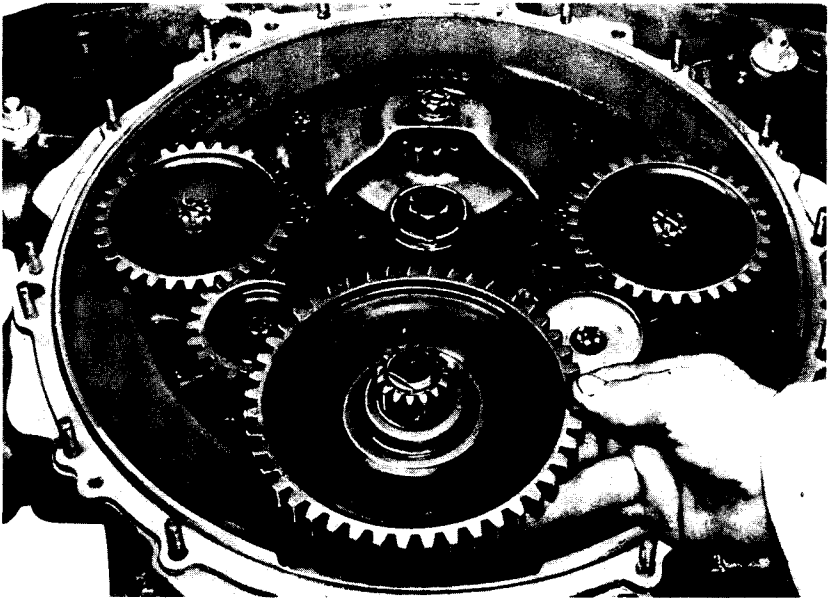

RA PD 309811

*Figure 48 — Removing Cranking Motor Drive Gear and
Cam Drive Pinion*

R975-C1 ENGINE (CONTINENTAL)

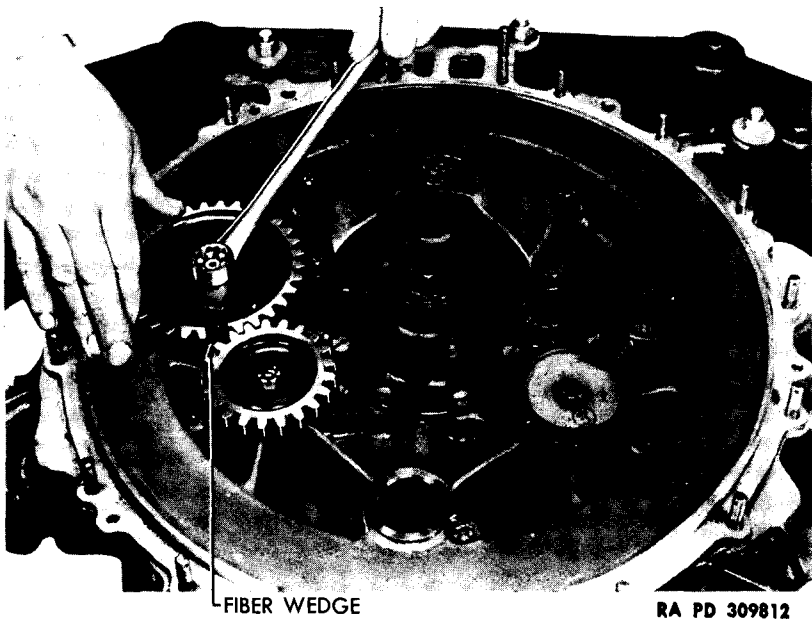

Figure 49 – Removing Accessory Drive Gear Nut (Magneto Drive)

Withdraw the cranking motor shaft through the opening in the rear section (fig. 47). Turn the overhaul stand to place the engine front side up, and remove the cranking motor gear and pinion assembly (fig. 48).

w. **Remove Accessory Drive Gears.** Remove cotter pins from the accessory drive shafts, and block the gears from turning with a piece of fiber. Remove nuts from the two accessory drive shafts, and lift the gears off the shafts (fig. 49). Remove the two accessory drive gear keys from the shafts, and place in a container where they will not be lost.

x. **Remove Diffuser Section.** Remove cotter pins, nuts, and flat washers from the studs exposed by the removal of the above mentioned three gears (fig. 50). Three tapped holes are provided in the diffuser section flange for removal of the diffuser from the crankcase rear section. Install three pullers (41-P-2906-280) in the holes provided, and screw down one to two turns at a time, alternating in order, to keep the parting flanges parallel (fig. 51). The diffuser section flange is comparatively thin, so care must be exercised in

ORDNANCE MAINTENANCE — 9-CYLINDER, RADIAL, GASOLINE ENGINE
(CONTINENTAL MODEL R975-C1)

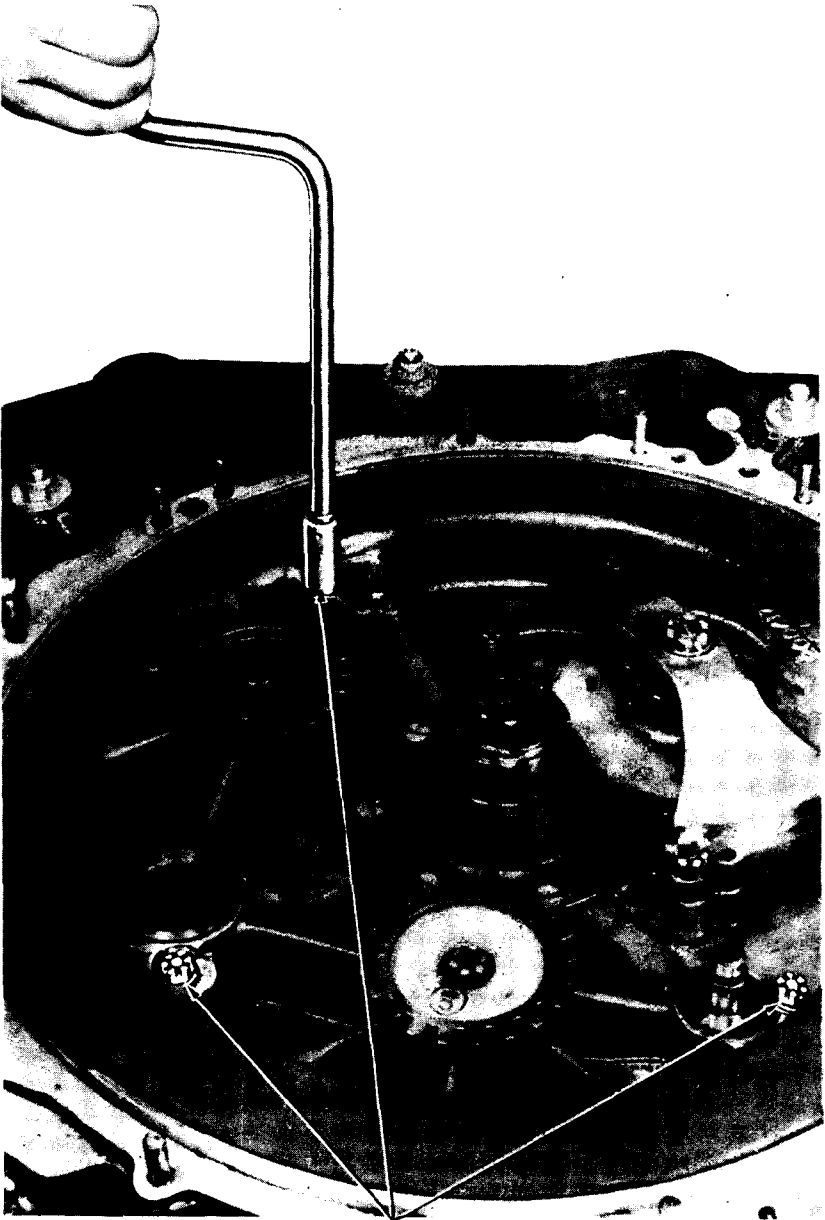

DIFFUSER SECTION STUD NUTS

RA PD 309813

Figure 50 — Loosening Diffuser Section Spacer Stud Nuts

R975-C1 ENGINE (CONTINENTAL)

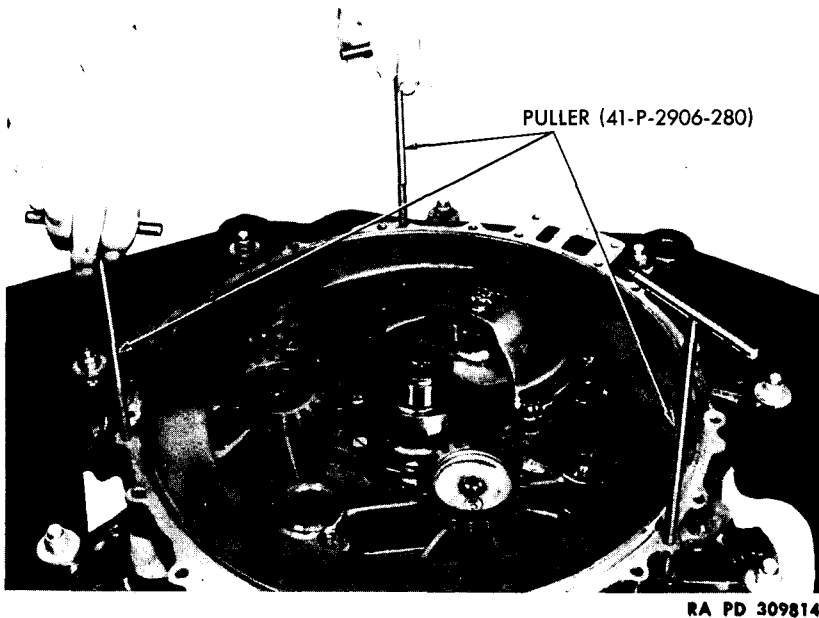

RA PD 309814

Figure 51 – Removing Crankcase Diffuser Section From Rear Section

removal of the unit. Do not force pullers to remove the diffuser section. If it appears to stick, tap lightly around the edges while slowly turning the pullers.

Section III

**INTRODUCTION TO OVERHAUL OF ENGINE
SUBASSEMBLIES**

8. GENERAL DISASSEMBLY INSTRUCTIONS.

a. General instructions applying to the disassembly of unit sub-assemblies correspond to those outlined in paragraph 5.

9. GENERAL CLEANING INSTRUCTIONS.

a. **Water Soluble Cleaners.** The use of water soluble cleaning compounds on engine parts is strongly discouraged. It has been found that small traces of water soluble alkaline cleaners sometimes remain impregnated in the pores of the metal. Later, during engine operation, the alkali may be released and get into the lubrication system to cause violent oil foaming.

**ORDNANCE MAINTENANCE — 9-CYLINDER, RADIAL, GASOLINE ENGINE
(CONTINENTAL MODEL R975-C1)**

b. **Volatile Cleaners.** Engine cleaner or dry-cleaning solvent are generally satisfactory for cleaning engine parts. Vapor cleaning is very effective for the same purpose. However, vapor degreasers leave the parts perfectly dry when removed from the cleaning tank, and a light oil spray is needed for protection against corrosion.

c. **Antifriction Bearings.** Space on perfectly clean benches should be provided for bearings. When abrasive dirt once gets into the separator pockets and on the races, it is not always easy to remove. Be careful not to risk adding more dirt by laying bearings on a dirty bench, either before or after cleaning. Use dry-cleaning solvent in a clean container. Do not wash bearings in the same fluid used to wash other engine parts. Slush the bearings around in the solvent, and finally revolve by hand while submerged to remove all grease, oil, or dirt. Compressed air may be used to blow bearings dry provided that the air is clean and free from all traces of moisture, and provided that the bearing races are held tightly to prevent spinning. **NOTE: Under no circumstances will a ball or roller bearing be permitted to spin when drying with an air blast.** Always relubricate bearings immediately after they have been washed and allowed to drain. They should be turned slowly by hand in clean new engine oil until the dry-cleaning solvent has been removed. As soon as bearings are cleaned and oiled, they should be wrapped in oiled paper or placed in a dustproof container.

d. **Oil-impregnated Bearings.** The cleaning of engine parts, in which oil-impregnated bearings have been installed, will be accomplished by immersion in dry-cleaning solvent or engine cleaner. The impregnated bearing is, in effect, a metallic sponge designed to retain oil within its pores, and cleaning or immersion in a solvent removes this oil supply. In some instances, the oil-impregnated bearing may be required to handle heavy loads before the engine oil pump has been operating long enough to saturate the bearing. For that reason, the pores of the oil-impregnated bearing must be refilled with oil after each cleaning and before reuse. For quick impregnation, heat a quantity of fresh engine oil, and submerge the part containing the bearing in the hot oil for a period of 15 minutes.

10. GENERAL INSPECTION INSTRUCTIONS.

a. **Engine Inspector.** The services of a competent and thoroughly trained engine inspector are to be considered as indispensable in arriving at decisions affecting further serviceability of any parts. An understanding of the function of every part of the engine, together with a knowledge of the conditions under which each operates, is essential.

R975-C1 ENGINE (CONTINENTAL)

b. **Magnetic Inspection.** The magnetic method of inspection for steel parts will aid in the detection of defects and fatigue cracks which otherwise could not be seen in the normal course of inspection. Its use is highly recommended for all steel parts in the engine except ball or roller bearings. The reason is that even very small traces of residual magnetism may cause pick-up of foreign particles that would be detrimental to satisfactory bearing operation. The operator of magnetic testing equipment must be a specialist in that field, who has been trained to evaluate correctly the various indications which may be encountered. Make sure all parts are completely demagnetized before reinstalling in the engine.

c. **Table of Limits.** The Table of Limits is to be used as a guide to the advisability of replacing any of the worn parts of the engine. It contains limits beyond which it is not considered good policy to continue parts in service.

11. GENERAL REPAIR INSTRUCTIONS.

a. **Standard Practice.** Certain repair instructions such as those concerning replacement of studs, polishing and reconditioning of bearing or bushing surfaces, repainting, installation of liners and bushings with the use of heat or dry ice, removal of scratches, nicks, and burs, and replacement of synthetic rubber oil seals and hose connections are common to similar parts used in all high-powered internal combustion engines. The requirements for reconditioning work of this nature will not be repeated under the detailed repair instructions unless there is a deviation from the accepted practices.

b. **Drive Fit Parts.** Where possible, all parts with a drive fit should be assembled with the aid of heat or dry ice, or both. Excessive heating or cooling of parts for ease of installation will not be used when there are obvious disadvantages to the procedure.

c. **Emery Cloth and Steel Wool.** Emery cloth and steel wool have no place in the reconditioning shop for high-powered engines. It is difficult to completely remove abrasive particles from the parts, and, if allowed to remain, they are particularly detrimental to engine life. In addition, the use of these materials may cause scratches which will not be visible to the eye, but which may develop into cracks that could easily be responsible for an engine failure.

d. **Identification Numbers.** Care should be used when remarking position numbers on parts. The numbers should be located in the same area used by the manufacturer when the engine was originally assembled. *CAUTION: When using an electric etching pencil to identify antifriction bearings, make certain that the bearing race on which the writing will be done is grounded to the machine and the other race*

**ORDNANCE MAINTENANCE — 9-CYLINDER, RADIAL, GASOLINE ENGINE
(CONTINENTAL MODEL R975-C1)**

is hanging free. If the electric circuit is completed across the bearing rollers or balls, arcing will probably occur and burn the highly polished rolling surfaces. Difficulty of this nature will seldom be detected by the usual inspection procedures, but it represents a serious hazard to safe engine performance.

e. Machining Dimensions. Where maximum and minimum limits on any dimension are given in the text, it is to be understood that an attempt will be made to obtain the mean dimension between the two limits. It is not always easy, or even possible, to machine parts to an exact specific size. For that reason only, permissible tolerances are given between which satisfactory operation can be expected. Always work to the mean dimension between specified limits, and there will be less possibility of parts being discarded because they are undersize or oversize.

f. Sealing Compounds. Unless otherwise noted in the text, sealing compounds of any kind are not to be applied to bushings, bearings, or adapters prior to installation. Sealing compounds clog pores in oilite bushings, plug drilled oil passages, and are generally detrimental to satisfactory engine operation when used for any purpose other than that for which they are intended. If necessary, a light coating of graphite lubricant may be used to aid in assembling, but no other material.

g. Replacement of Studs. Replacement of steel studs driven in aluminum alloy parts requires good judgment as well as a great deal of care on the part of the mechanic. Unless the replacement is properly made, more difficulties may be encountered than would have been, had no attempt been made to correct the original trouble.

(1) The first problem is not just to get the broken or damaged stud out, but to get it out without injury to the part in which it has been set. A stud driver or a small pipe wrench may be used if only the outside threads are damaged. Apply pressure on the handle of the tool being used in such a manner that there will be no tendency to bend the stud. Back the stud out slowly to avoid overheating of the threads. It should be remembered that any thread lubricant or sealing material used when the part was originally installed has probably congealed, and rapid withdrawal of the parts may cause damage to the mating threads.

(2) Either of two methods has been used successfully to remove studs broken off at or near the surface. The center section of the stud may be drilled out, where size permits, and a square-shanked stud remover installed. Use a wrench of the proper size, and back the stud out carefully. If this method does not work satisfactorily, it

R975-C1 ENGINE (CONTINENTAL)

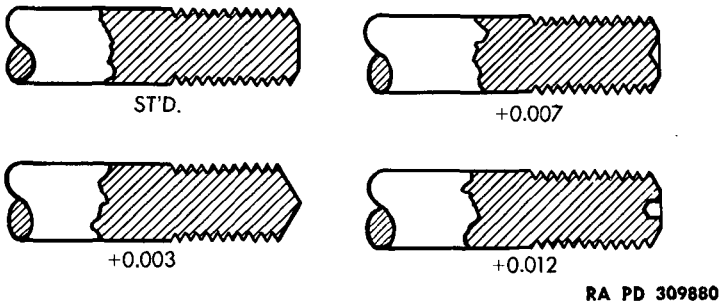

Figure 52 – Identification of Oversize Studs

may be possible to electric weld a short piece of steel bar stock or a steel nut to the broken stud. The bar stock or the nut may then be used to withdraw the broken piece. Welding must be done carefully to avoid melting or damaging the metal around the base of the stud.

(3) The threads in whatever part the stud is to be replaced should be cleaned up before attempting to drive a new stud. Be sure that the tap to be used for this operation is the correct size. New taps usually cut oversize, and the mechanic should handle them carefully. If the tap appears to be cutting material away instead of just cleaning out the threads, withdraw it and use an older tool. Rough edges or burrs on a tap will cut an improper thread and such a tap should not be used.

(4) Oversizes of 0.003 inch, 0.007 inch, and 0.012 inch are supplied to replace the standard studs. These studs may be identified by the machining on the end that is driven into the housing (fig. 52). Examine the stud removed to determine what size it is, and install the next oversize stud available.

(5) Apply a conservative quantity of thread lubricant to the threads on all studs before installation. Some types of thread lubricant require that they be stirred before use.

(6) Before installing a stud, make certain that it is the correct part and that the right end will be inserted in the housing. Examine the new stud carefully, since these parts easily become mixed in stock.

(7) When driving the stud, feed it in carefully until reasonably sure the threads are meshing properly. Then turn in slowly and steadily until the stud is approximately in position. A torque-indicating T-handle should always be used in conjunction with the stud driver. Drive to the specified torque values. Care must be taken that studs do not bottom in blind holes or false torque readings will result.

**ORDNANCE MAINTENANCE — 9-CYLINDER, RADIAL, GASOLINE ENGINE
(CONTINENTAL MODEL R975-C1)**

(8) Do not turn the studs in rapidly, or it is possible that the threads may overheat and either seize or be damaged.

h. Removal of Scratches. Certain precautions outlined in the following text must be observed when removing scratches, nicks, or burs from engine parts.

(1) Probably the most important item to remember in connection with repairs of this nature is that a large percentage of the scratches and surface damage that may be found is the result of careless handling in the shops. If the parts are handled carefully throughout every department of the repair shop, there is little chance that they will be damaged. The only way that a part can be scratched while it is in the engine is to have dirt or solid material get into the oil and induction systems. So it is well to keep in mind that there will be little need for instructions on the correct way to repair damage of this kind if good shop methods are practiced.

(2) Crocus cloth is recommended as the best material available for removing small scratches in comparatively hard metals. Always keep the cloth wet with dry-cleaning solvent. Clean off a sufficient amount of material to eliminate all traces of the original scratch. It may be necessary at times to use a fine stone in order to completely remove deep scratches. The use of a stone is permissible where necessary, but crocus cloth is preferred in most cases.

(3) The glazed surfaces of bushings should not be disturbed by cleaning with crocus cloth or a stone unless this is necessary to clean up scratches or scoring.

(4) Greatest care will be used when stoning gear teeth to remove nicks or burs. The tooth profile is altered by excessive stoning, and flat spots are usually formed. Any alteration of the contour on a gear tooth imposes heavy loads on the remaining high spots, and may lead to failure. Nicks, burs, or pitting below the normal tooth surface will not be removed, as no operating improvement is thereby accomplished. The gear can be expected to operate more satisfactorily with small pits than it would if the defects were removed by stoning. If the gear is severely pitted or damaged, it should be discarded and a new gear installed.

i. Installation of Spare Parts. Certain assemblies and detail parts supplied for replacements may require line reaming or similar operations at first assembly on the engine. Whenever possible, special fixtures are used to perform these operations during manufacture, to eliminate this machining at assembly. In either case, wax or semisolid grease is often used to fill oil passages where metal chips from the machining operations might collect. If the wax or grease used for

R975-C1 ENGINE (CONTINENTAL)

this purpose is not completely removed before the engine is assembled, improper lubrication will result. It is recommended that whenever spare parts are to be assembled in an engine, an inspection be made to insure that all oil passages are clear. Remove all traces of corrosion preventive compound from the parts by thoroughly washing in dry-cleaning solvent.

j. Machining Oilite Bushings. Never ream, scrape, bore, or hand burnish an oilite type bushing. This type of metal is porous in nature and provides lubrication to the shaft by means of oil seepage through the porous openings. If reaming, scraping, or hand burnishing is attempted, these operations will seal the pores and prevent proper lubrication. Broaching to size is the only recommended method.

12. GENERAL ASSEMBLY INSTRUCTIONS.

a. Cleaning Parts. Before any part is installed, the mechanic should make sure it is thoroughly clean. If parts cleaned in dry-cleaning solvent are not thoroughly dry before assembly, the lubricating oil will be diluted. For this reason, the parts may suffer from lack of initial lubrication. Never use a cloth to remove dust or dirt from engine parts. Lint from the rag collects in the lubricating system and may clog oil lines or filters.

b. Pre-oiling. When an engine is started, it may require several revolutions before the oil pump is delivering a supply of lubricant to the farthest points. This means that unless these parts have been well coated with oil at assembly, they will probably operate dry for a few seconds when the engine is first started.

c. Torque Wrenches. The use of a suitable torque-indicating wrench shall be considered as an absolute requirement when tightening any parts for which torque values are specified.

d. Standard Replacements. Certain items such as gaskets, hose, clamps, lock wire, oil seals, cotter pins, palnuts and bolt head locking plates should not be used a second time. Reuse of any such parts is poor economy from the standpoint of safe engine operation. Therefore, use all new safety, locking, and gasket material each time the engine is assembled.

e. Cotter Pin and Lock Wire Installation. Cotter pins and lock wire should be selected to fit snugly in the drilled holes where they are used. When the cotter pin is used to lock a castle nut, the looped end of the pin should set inside the castellation; not outside or across it. Unless otherwise specified, one tab of the cottor pin should be bent up and over flat against the top of the bolt or stud. The other tab should be bent down against the side of the nut. Lock wire should be twisted evenly and drawn up tightly. Loose lock wire may

**ORDNANCE MAINTENANCE — 9-CYLINDER, RADIAL, GASOLINE ENGINE
(CONTINENTAL MODEL R975-C1)**

vibrate a sufficient amount during operation of the engine to wear through the wire. This is especially true since the lock wire is most generally assembled around sharp edged parts.

f. Castellated Nut Installation. Never back off a nut to line up castellations with the hole drilled in a bolt or stud for inserting lock wire. If the nut must be tightened excessively, or the specified torque limit exceeded, use either a new washer or a new nut.

g. Free Movement of Parts. When a unit subassembly of the engine is being built up, it will be advisable to check for free movement after each moving part is installed and secured in place. See that the part turns freely with no binding, rubbing, or interference of any kind. If difficulty is noted immediately after any particular part has been assembled and it was not evident before, there should be little trouble in locating the cause and taking corrective action.

h. Assembly Order. Lock all bolts, nuts, and other items requiring it as the assembly progresses. Do not wait until the subassembly has been completed, or some of the nuts will be missed. Every assembly should be completed before leaving it. If there is not sufficient time left to finish the work, it should not be started. As soon as each subassembly is completed, plug or cover all external openings, and leave them plugged until it is necessary to open them. This is important, since nuts, washers, and palnuts may be accidentally dropped in and result in damage to the engine when it is operated. The mechanic should guard against small pieces of lock wire getting into the engine when trimming the ends with side cutters.

Section IV**OVERHAUL OF THE CRANKCASE FRONT SECTION****13. DISASSEMBLY OF THE FRONT SECTION.**

a. Separate Parts. Disassembly of the crankcase front section will be confined to removal and separation of the front scavenge oil pump since that is the only unit included as a part of this section and normally disassembled at overhaul of the engine. Remove the cotter pin and castellated nut that secure the oil scavenge pump drive gear, and lift the gear off (fig. 53). A fiber hammer may be used to loosen the gear. Unscrew castellated nuts that retain the pump housing, and lift the pump out (fig. 54). The pump gears may then be removed by separating the housing and cover. Do not pry under the cover to get it off.

R975-C1 ENGINE (CONTINENTAL)

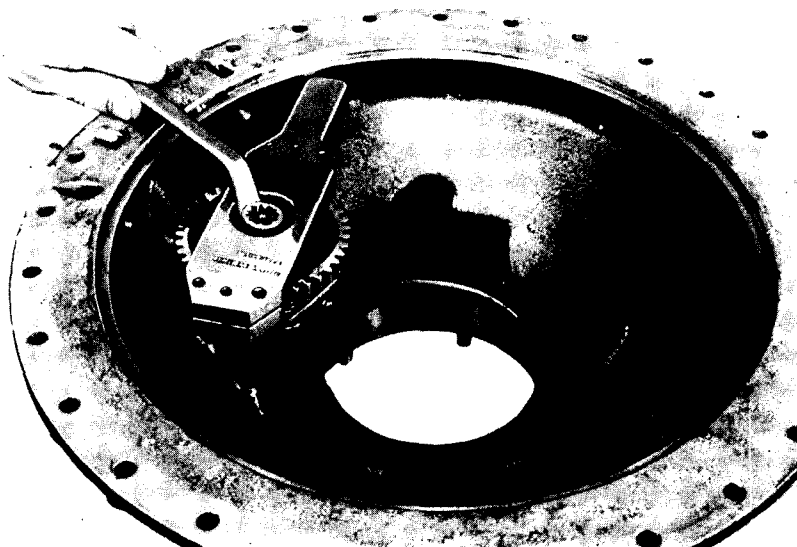

RA PD 309835

Figure 53 — Removing Front Section Scavenge Pump Gear Nut

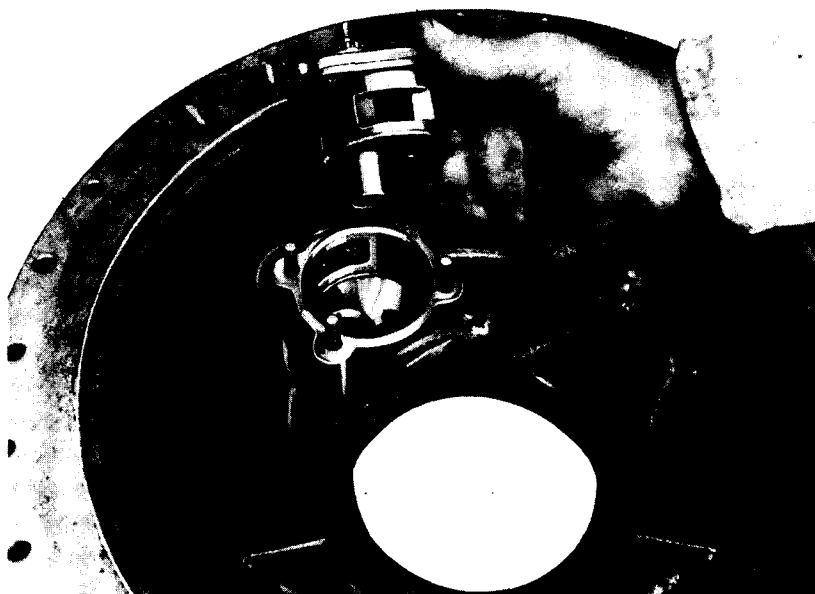

RA PD 309836

Figure 54 — Removing Front Section Scavenge Pump

ORDNANCE MAINTENANCE — 9-CYLINDER, RADIAL, GASOLINE ENGINE
(CONTINENTAL MODEL R975-C1)

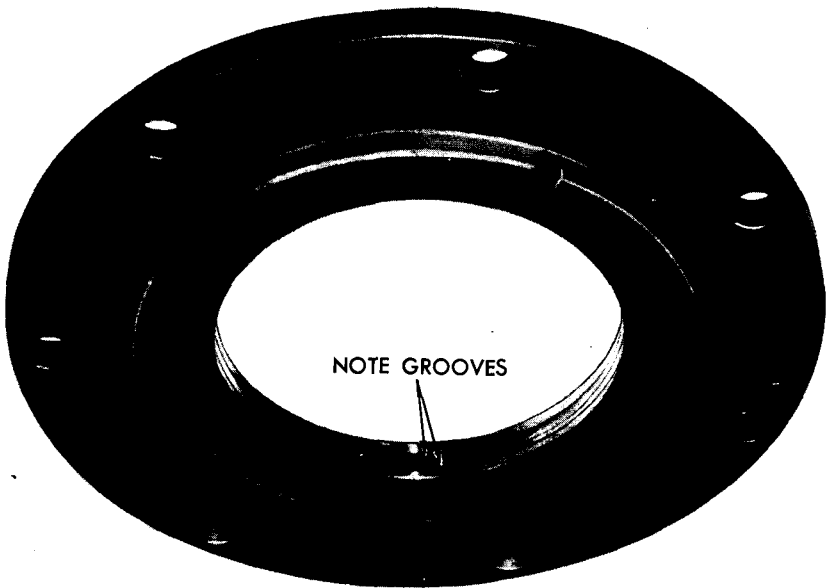

RA PD 309886

Figure 55 — Front Section Cover

14. CLEANING THE FRONT SECTION.

a. **Wash Parts.** All parts must be washed in dry-cleaning solvent and laid out for inspection. The thrust ball bearing must be cleaned in a separate container from other front section parts. Refer to the instructions contained in paragraph 9 c.

15. INSPECTION OF THE FRONT SECTION.

a. **Inspect Front Section Cover.** Examine the cover closely for cracks, and see that it has not been grooved by failure to put flat washers under the castellated nuts at previous assembly. The oil seal sleeve should be in place, tight, and show no evidence of grooving or burning caused by possible rotation of the oil seal rings (fig. 55). Check the front cover shims for bends or breaks. The shims must lay flat when assembled so there should be no sharp bends or creases. There should be no signs of rubbing, either on the oil slinger or the recess in the rear of the front plate. See that the flywheel hub cones have not been galled, grooved, or battered by a loose flywheel (fig. 56).

b. **Inspect Front Section Housing.** Check the housing closely for cracks, especially at the base of the studs and around the engine support tube attaching cap. Try all studs for security in the case, and notice condition of threads. Examine finished surfaces for scratches,

R975-C1 ENGINE (CONTINENTAL)

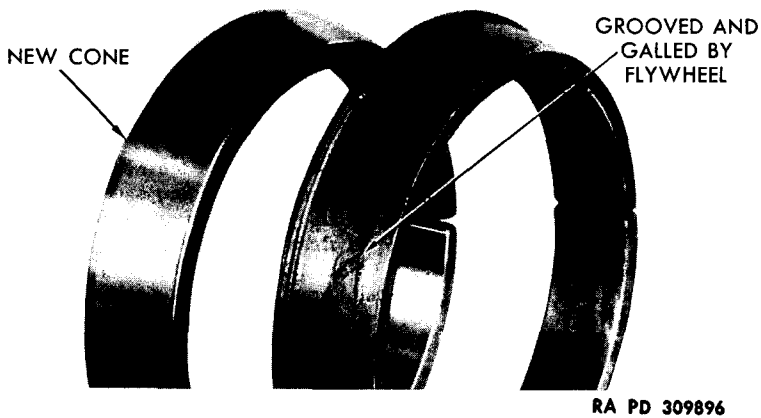

Figure 56 – Flywheel Hub Rear Cone

nicks, or high spots that might contribute to or cause oil leakage or misalignment. See that oil drain holes are clean and free from obstructions. There should be no indications of the thrust bearing turning in the housing. The housing is to provide a 0.0002- to 0.0022-inch loose fit for the outer race of the bearing.

c. **Inspect Front Crankshaft Gear.** Check the gear for wear, chipping, or pitting of the case hardened tooth faces. Examine the keyway and key for wear or damage.

d. **Inspect Front Scavenge Pump.** Examine the oil gear chamber of the housing to determine that no excessive scratching or damage has occurred. See that the gears have not worn into and grooved the housing or cover. Deep scratches or excessive wear (maximum 0.010-inch clearance) caused by the two gears seriously affects the efficiency of the pump. The gears should be free from nicks, burs, or sharp edges. Note particularly that the ends of the gears and the tops of the teeth are smooth. Allowable end clearance of the gears in the housing is a maximum of 0.006 inch. The driven gear rides on a stationary shaft mounted in the housing cover. Check for excessive wear (maximum 0.003-inch clearance) of the shaft.

e. **Inspect Front Main Bearing Support.** Inspect the support for cracks, and see that there are no nicks or burs on the parting flanges. The front main bearing support ring should be tight in the support and free from galling that may be caused by possible turning of the bearing outer race. Check fit of the support pilots with the crankcase front and main sections by placing one section on top of the other. The oil deflector plate should not be removed from the support unless it has been damaged; in which event, locate and correct the cause before replacing parts. Inspect oil deflector plate to see

ORDNANCE MAINTENANCE — 9-CYLINDER, RADIAL, GASOLINE ENGINE
(CONTINENTAL MODEL R975-C1)

that the opening in the deflector plate is towards the right side of the engine as viewed from the rear.

16. REPAIR OF THE FRONT SECTION.

a. Repair Front Section Cover. Slight irregularities of the steel oil sleeve may be smoothed over with crocus cloth wrapped around a small wood block. Deep grooving may be removed by grinding the sleeve oversize in the amount of either 0.005 or 0.010 inch. Mount the plate in the chuck of an internal grinder and center by indicating on the undamaged part of the sleeve. Oversized rings will be installed when the sleeve is ground oversize.

b. Repair Front Section Housing. Remove all traces of old gasket material from the parting flanges, and smooth over nicks or fine scratches with crocus cloth wrapped around a small wood block. Do not remove small dents or scratches; merely smooth the projecting edges over, flush with the main surface. No attempt will be made to weld or otherwise repair a cracked front section. If cracks are found, the part must be discarded.

c. Repair Front Crankshaft Gear. The gear may be stoned to remove nicks or burrs, but no other repairs should be necessary. Observe the precautions outlined in paragraph 10 h (4) when making repairs of this nature.

d. Repair Front Scavenge Pump. Excessive wear or damage to the pump housing can be corrected only by replacement with new parts. First be sure the oil pump gears are free from sharp edges, nicks, or burrs that could damage the new housing. Check to see that the gears turn freely in the new housing when it is tightened in place in the crankcase front section. Do not replace either the housing or the cover separately. If either part is damaged, they should both be replaced because the parts are machined together and doweled at original assembly. Observe the precautions outlined in paragraph 10 h (4), when stoning the gears.

e. Repair Front Main Bearing Support. The bronze front main bearing support ring is not serviced separately. Therefore, if this part loosens or is damaged, replace the entire front main bearing support assembly. Supports in which only the bearing ring is damaged will be reported to higher authority and held for reclamation by replacement of the ring at the factory. When installing a new support, check the pilot fits on the crankcase main and front sections, particularly around the stud hole locations. It is important that this fit be correct to prevent the front main bearing loads being carried by the studs at the parting flange of the crankcase main section.

R975-C1 ENGINE (CONTINENTAL)

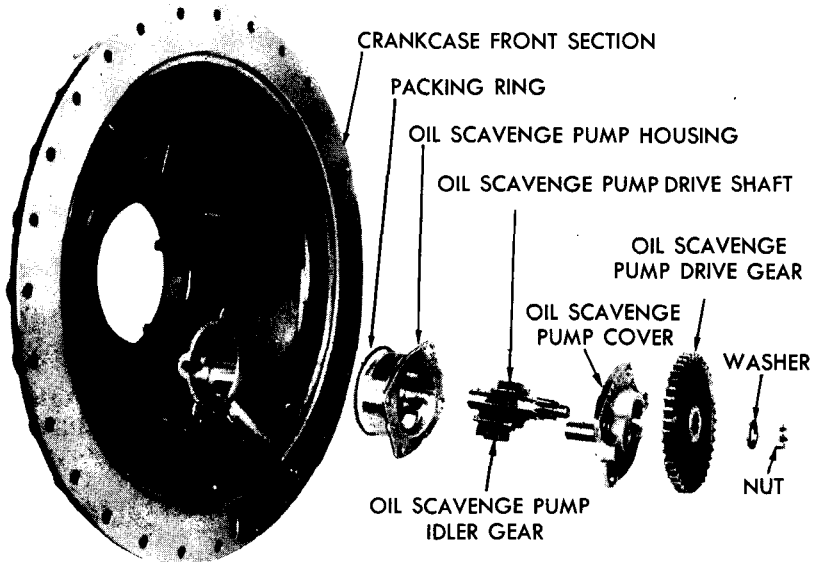

RA PD 309755

Figure 57 — Front Section Scavenge Oil Pump Disassembled

17. ASSEMBLY OF THE FRONT SECTION.

a. **Assemble Scavenge Pump.** Reinstall front oil scavenge pump parts in the crankcase front section, and check for free movement (fig. 57). Secure the castellated nuts with cotter pins, and assemble the drive gear on the splined shaft. Other parts of the front section will not be assembled until final assembly of the engine.

Section V

OVERHAUL OF THE CRANKCASE MAIN SECTION

18. DISASSEMBLY OF THE MAIN SECTION.

a. **Remove Piston Rings.** Disassembly requirements include only removal of the piston rings. No particular effort need be made to remove the rings in good condition, since it is recommended that all new rings be installed at each engine overhaul. However, it is important that no damage be done to the piston at this time. Avoid scratching or marking the piston in any way, particularly the sides of the ring grooves.

b. **Remove Knuckle Pins and Articulated Connecting Rods.** Flatten the screw locking tabs, and remove the knuckle pin lock

ORDNANCE MAINTENANCE — 9-CYLINDER, RADIAL, GASOLINE ENGINE
(CONTINENTAL MODEL R975-C1)

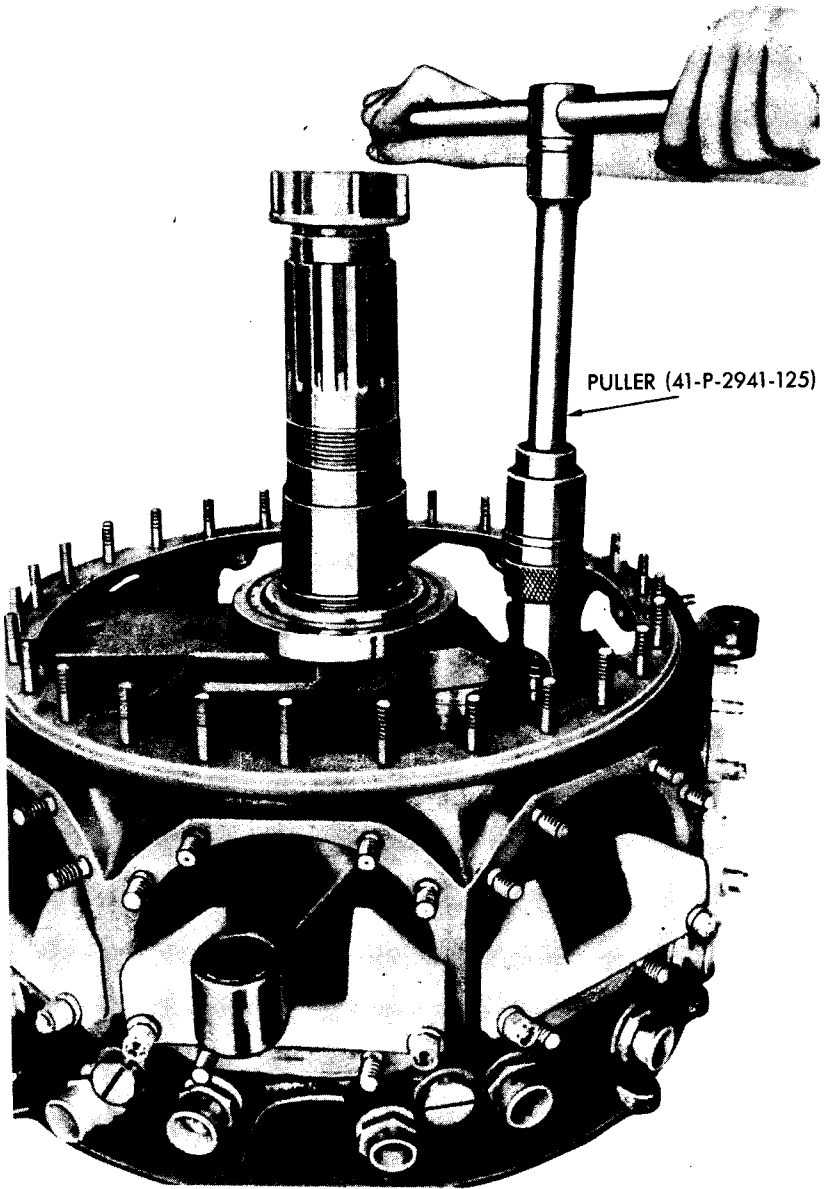

RA PD 309819

Figure 58 — Removing Knuckle Pin

R975-C1 ENGINE (CONTINENTAL)

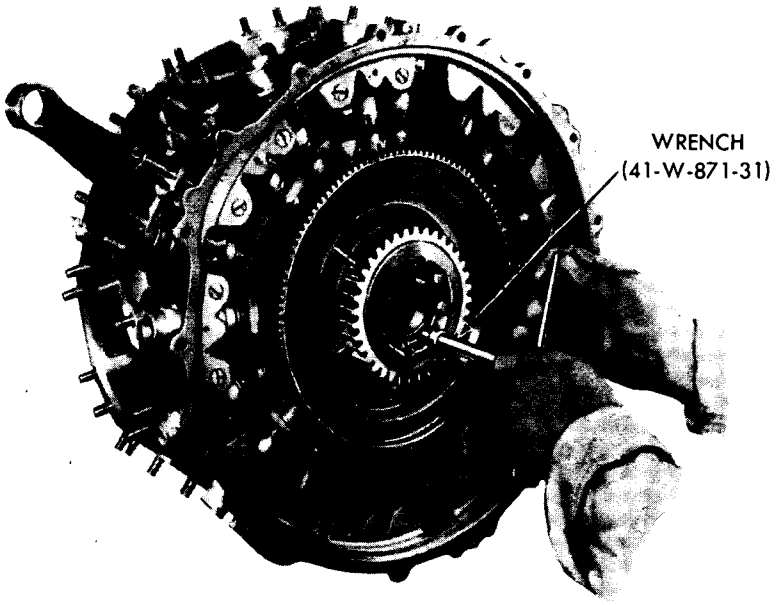

RA PD 309820

Figure 59 – Removing Rear Crankshaft Gear Hub Screws

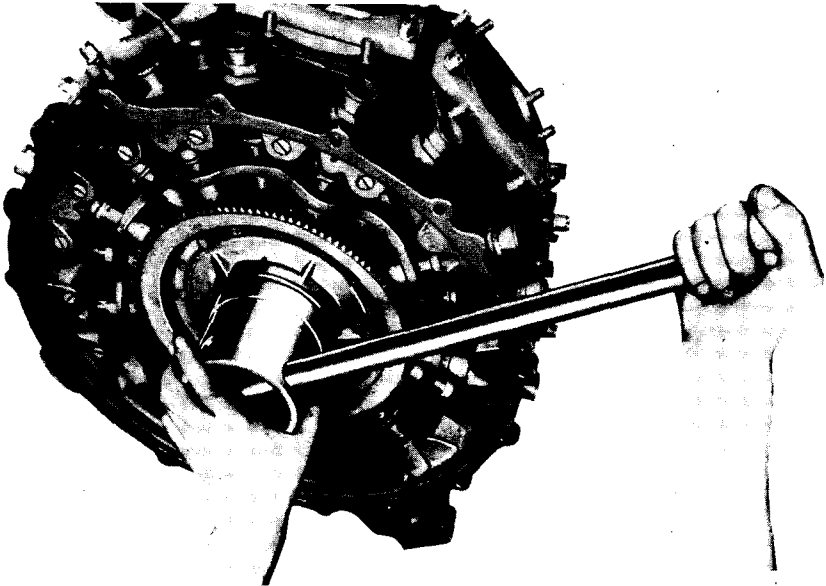

RA PD 309822

Figure 60 – Removing Cam Hub Bearing Support

ORDNANCE MAINTENANCE — 9-CYLINDER, RADIAL, GASOLINE ENGINE
(CONTINENTAL MODEL R975-C1)

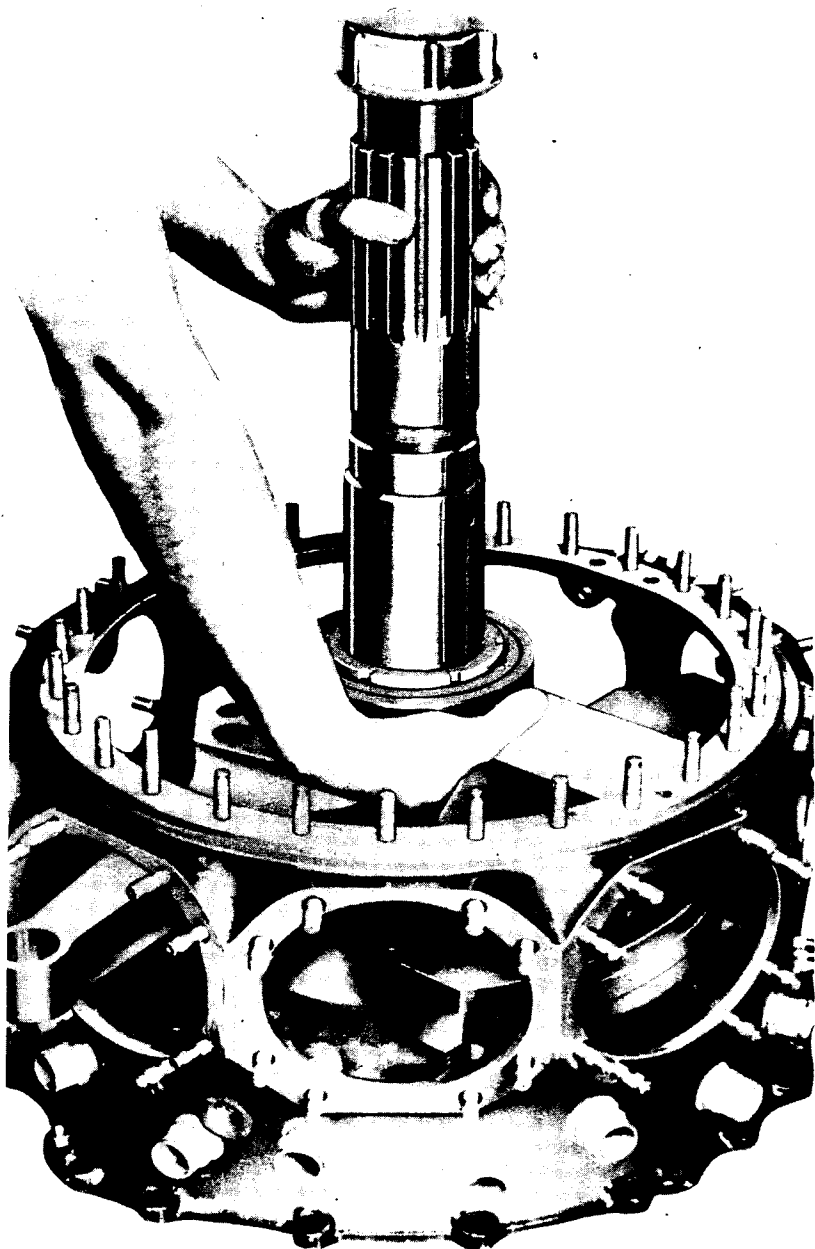

RA PD 309821

*Figure 61 — Removing Crankshaft and Master Rod From
Crankcase Main Section*

R975-C1 ENGINE (CONTINENTAL)

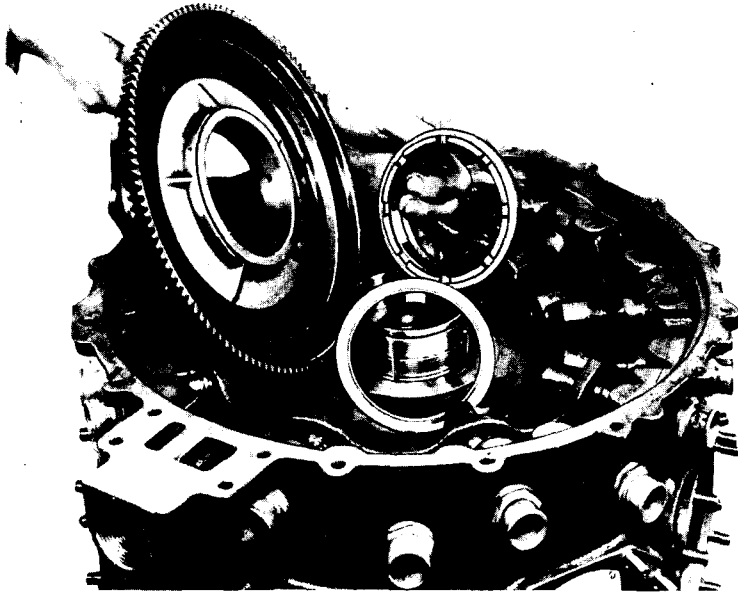

RA PD 309823

Figure 62 -- Removing Cam, Spacer, and Bearing

plate cap screws. Use a small brass drift, and drive the locking plates off the outer edge of the master rod. Do not force a screwdriver or similar tool between the lock plate and the master rod. Install the puller (41-P-2941-125), and remove all knuckle pins and articulated connecting rods (fig. 58). Do not allow the connecting rods to fall or bump against the crankcase while removing. The master rod cannot be removed until the crankshaft has been separated.

c. **Remove Crankshaft.** Detach lock wire, and remove cap screws (wrench 41-W-871-31) attaching the crankshaft gear to the rear of the crankshaft (fig. 59). Lift the gear assembly off. Remove the spring retainer from the crankshaft gear assembly, and pry out each spring with its two pins. Turn the hub within the gear until the locks of the gear are no longer engaged by the slots in the hub, and separate the hub and gear. Remove cotter pins from the cam hub bearing support, install the lug wrench, and loosen the bearing support (fig. 60). Turn the main section on its side, and withdraw the crankshaft (fig. 61). To do this, turn the shaft until the counterweights are at the right side approximately 90 degrees from No. 1 cylinder location. Be careful not to damage the rear main bearing when lifting out the crankshaft.

d. **Remove Cam and Valve Tappets.** Unscrew the loosened cam hub bearing support, and lift off the cam and the cam hub bearing

**ORDNANCE MAINTENANCE – 9-CYLINDER, RADIAL, GASOLINE ENGINE
(CONTINENTAL MODEL R975-C1)**

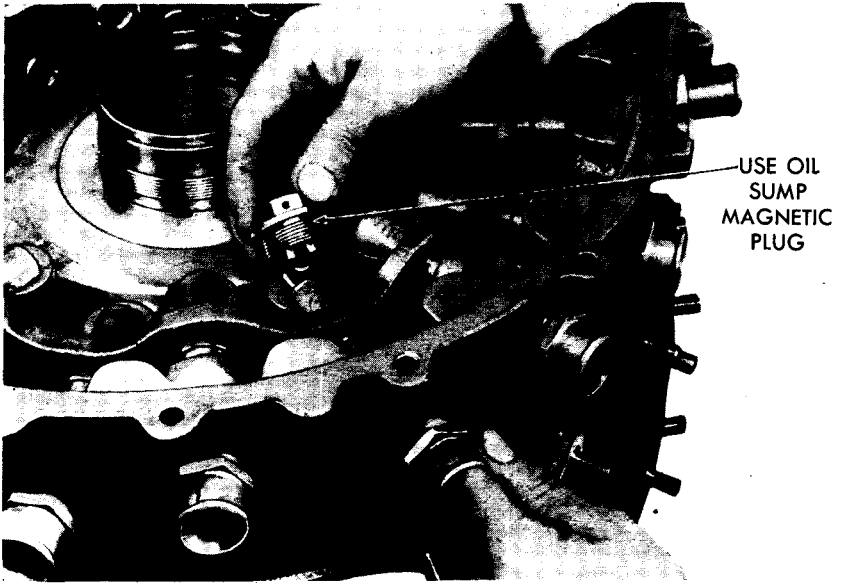

RA PD 309824

Figure 63 – Removing Tappet Roller Pins and Rollers

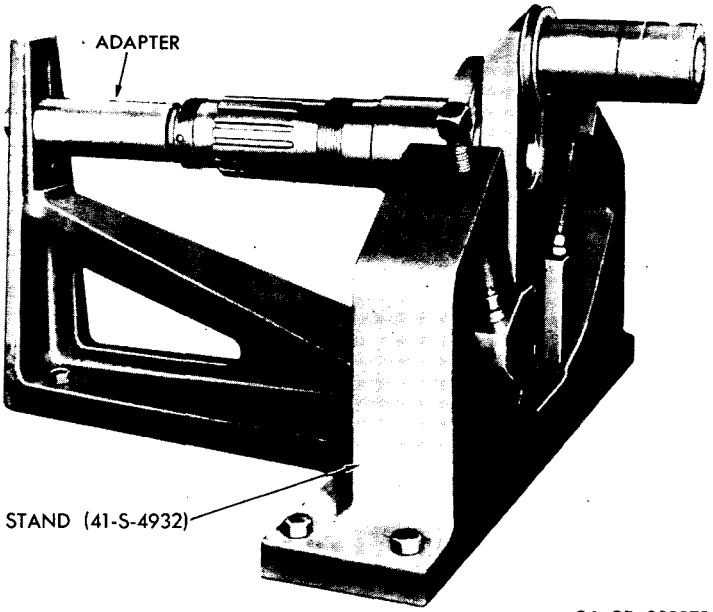

RA PD 309871

Figure 64 – Crankshaft Disassembly and Assembly Stand

R975-C1 ENGINE (CONTINENTAL)

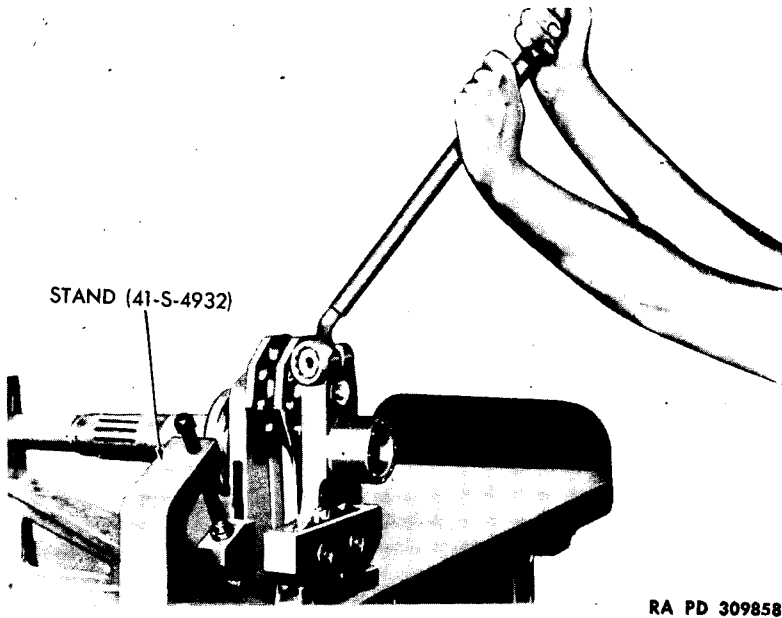

RA PD 309858

Figure 65 — Loosening Rear Crankcheek Cap Screw

spacer (fig. 62). Push tappets toward the center, and remove roller pins with a small magnet (fig. 63). Remove rollers and withdraw the tappets. Tappet guides are shrunk into the housing and should be left in place unless inspection indicates the need for replacement.

e. Rear Main Bearing. The rear main bearing is shrunk in place in the main section and should not be removed unless it is found at inspection that replacement is necessary.

f. Separate Crankshaft. Place the crankshaft in the crankshaft disassembly and assembly stand (41-S-4932) (fig. 64). Remove the cotter pin from the rear crankcheek cap screws. Remove the cap screw by attaching an extension handle to a box wrench of the correct size (fig. 65). Insert the rear crankshaft spreading tool, and pull the rear crankshaft off from the crankpin (fig. 66).

g. Remove Master Rod. Slide the master rod from the crankpin. Remove the crankshaft front end from the holding fixture and clamp in the jaws of a vice padded with copper or aluminum jaws. Remove cotter pin from the front main bearing lock nut, and unscrew the nut with the special lug wrench (41-W-871-27). Use care to prevent marring the shaft (fig. 67). Lift off the roller bearing and spacer. Bend the lock plate tab down, and remove the crankpin bore plug

ORDNANCE MAINTENANCE — 9-CYLINDER, RADIAL, GASOLINE ENGINE
(CONTINENTAL MODEL R975-C1)

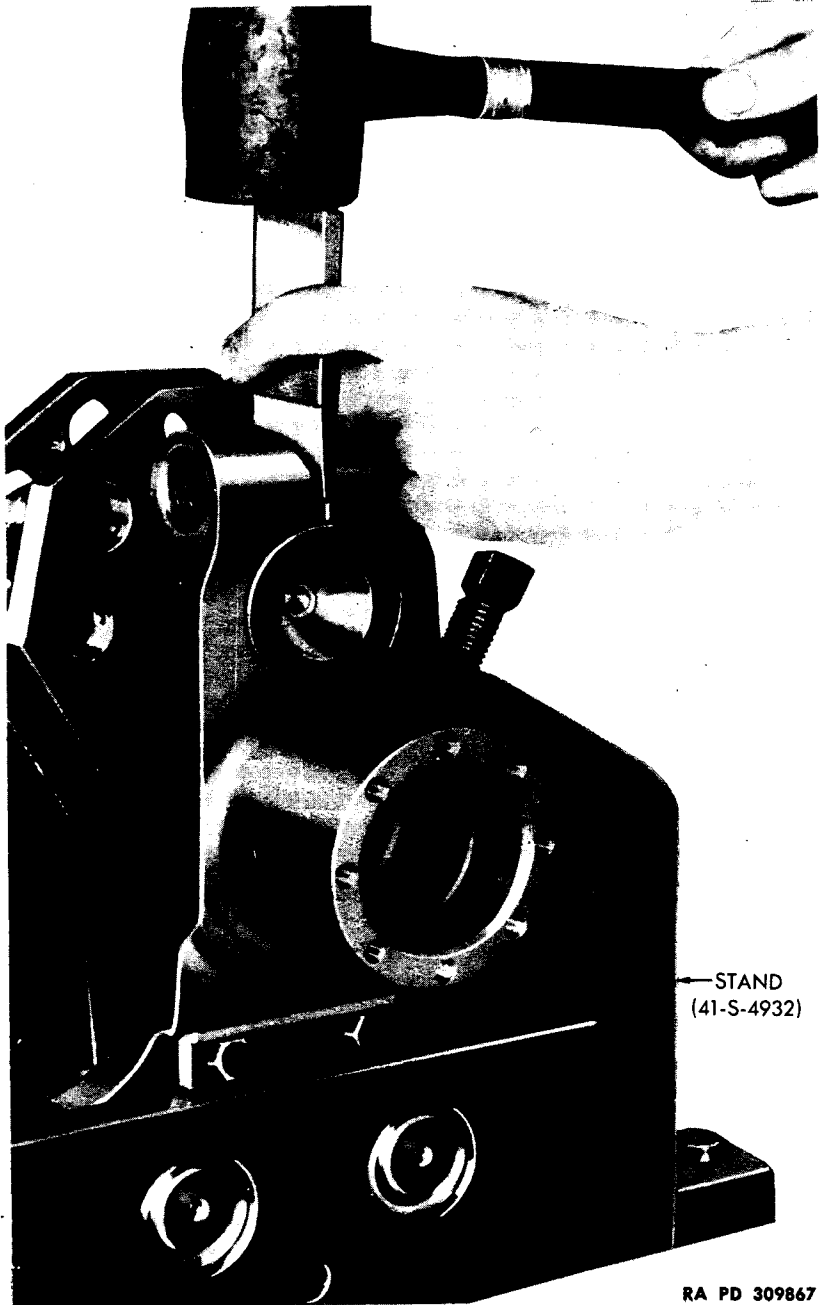

STAND
(41-S-4932)

RA PD 309867

Figure 66 — Spreading Rear Crankcheek

R975-C1 ENGINE (CONTINENTAL)

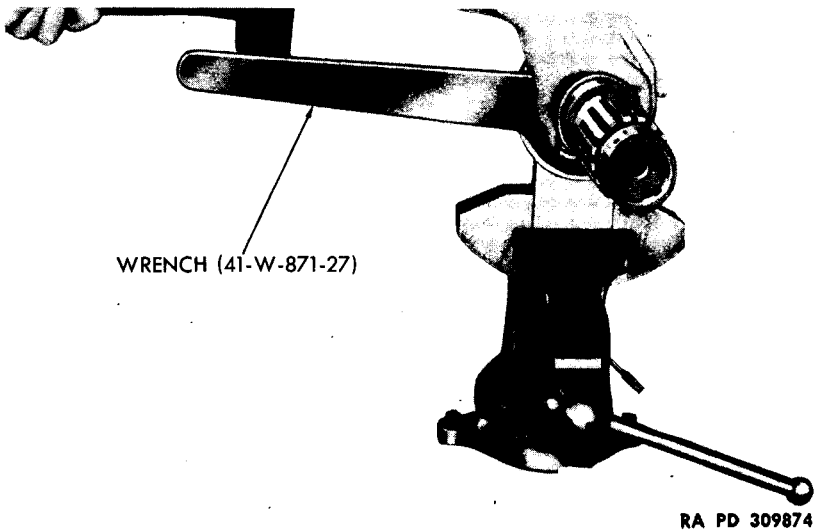

Figure 67 — Loosening Front Main Bearing Lock Nut

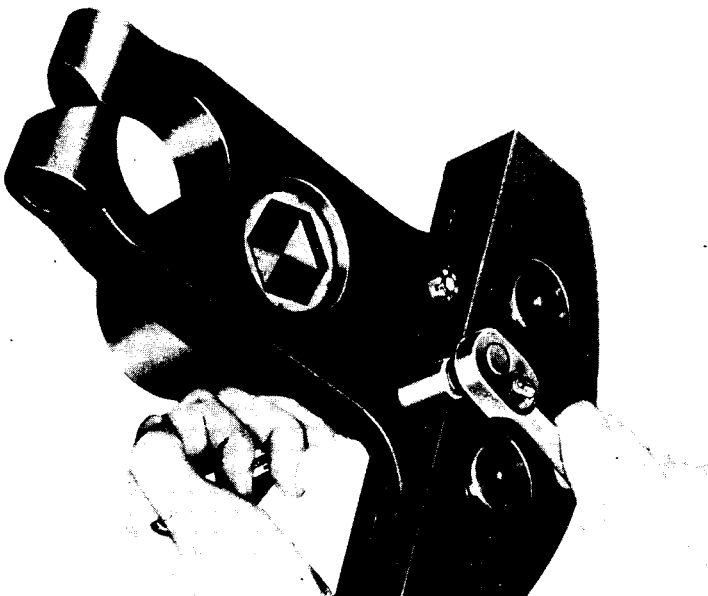
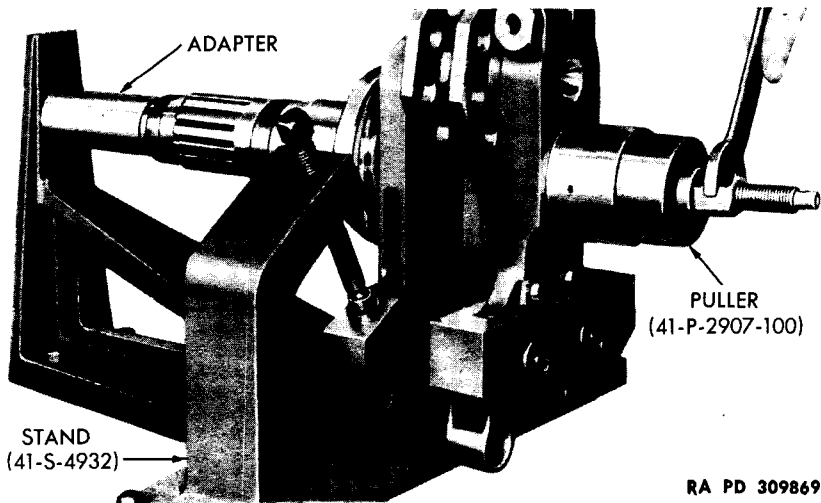

Figure 68 — Unscrewing Nut From Dynamic Damper Stop Bolt

**ORDNANCE MAINTENANCE — 9-CYLINDER, RADIAL, GASOLINE ENGINE
(CONTINENTAL MODEL R975-C1)**



RA PD 309869

Figure 69 — Removing Plug From Rear Crankshaft

retaining cap screw. The plug may be removed by installing a suitable puller in the tapped hole provided.

h. Disassemble Rear Crankshaft. Remove cotter pins from the rear crankcheek dynamic damper stop bolt nuts (fig. 68). Unscrew the nuts, and remove the bolts and stop. Align holes of the dynamic damper with those in the crankcheek extension and withdraw the pins. Slide the damper weight from the crankcheek. Install a puller (41-P-2907-100) in the tapped hole provided, and remove the crankshaft rear plug (fig. 69).

i. Loosen Valve Locks. Place a cylinder on the valve removing and installing stand (41-S-4988-77). Use a fiber drift of cylindrical cross section to loosen the valve spring retaining washer and the valve locks. Place one end of the drift on the upper washer, concentric with the valve stem, and strike sharply with a fiber hammer.

j. Remove Valve Springs. Install the valve spring compressor (41-C-2559-25), compress the valve springs (fig. 70), and remove the split locks. Remove the valve spring compressor, and lift out the springs and spring washers. Turn the cylinder around on the wood block, and remove the remaining set of springs and washers from the other valve in the same manner. Do not remove the small circllets from the valve stems at this time.

k. Remove Valves. Lift the cylinder off the wood block and set on its side on the bench. Remove safety circllets from the valve stems, and examine the protruding ends for any small nicks or burs that

R975-C1 ENGINE (CONTINENTAL)

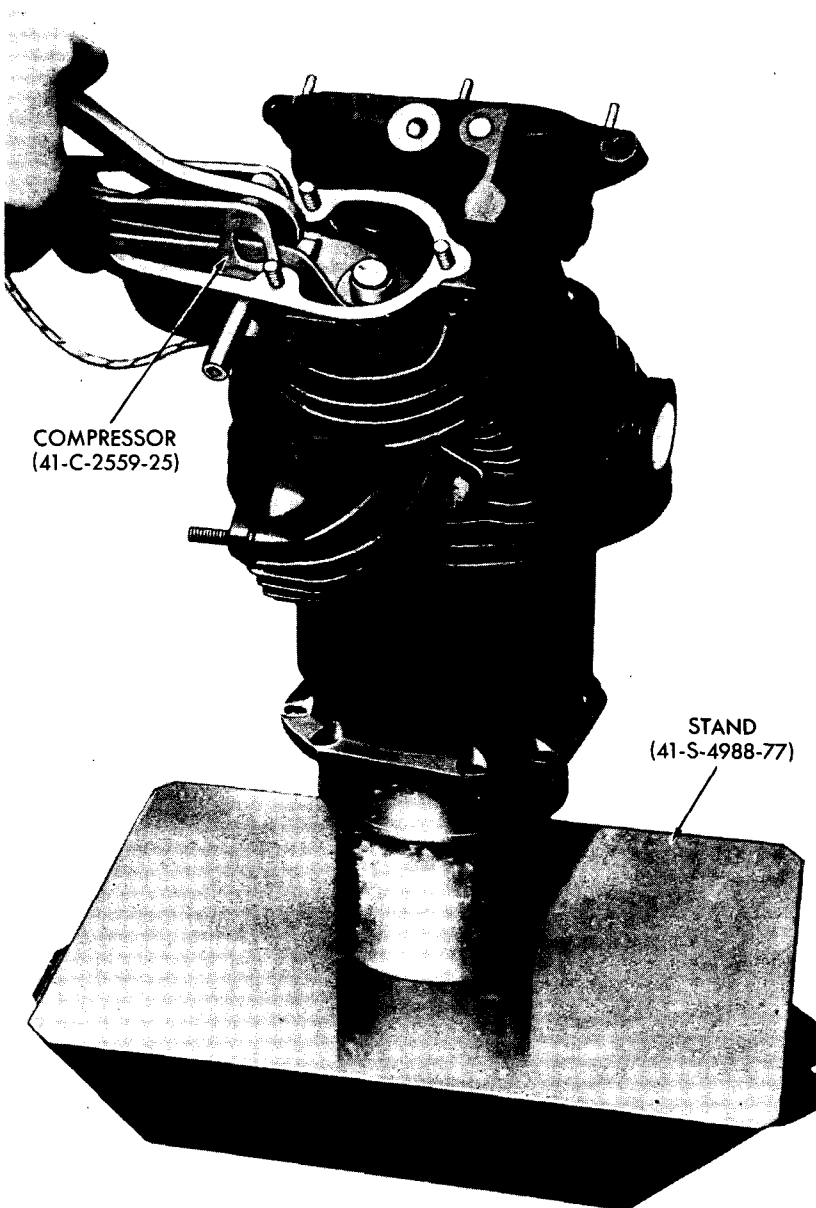

RA PD 309827

Figure 70 — Compressing Valve Spring To Remove Split Locks

ORDNANCE MAINTENANCE — 9-CYLINDER, RADIAL, GASOLINE ENGINE
(CONTINENTAL MODEL R975-C1)

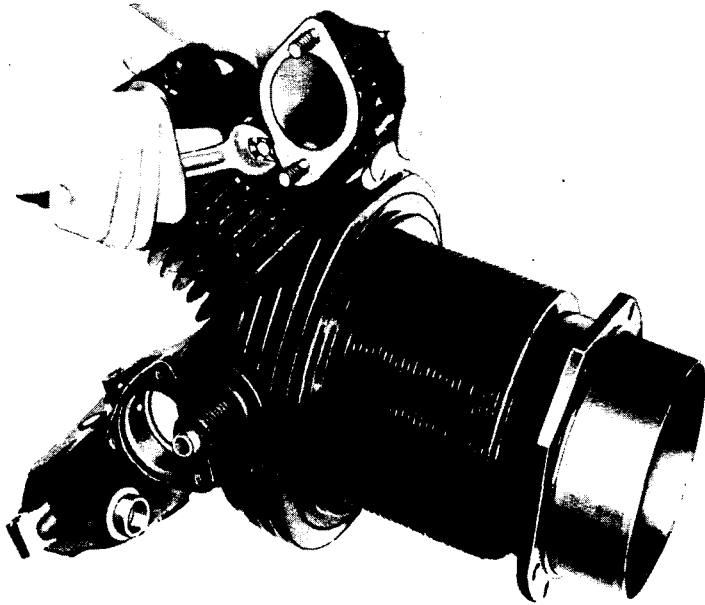

RA PD 309826

Figure 71 — Removing Exhaust Elbow, Using Wrench (41-W-1471)

could damage the guide when the valve is pulled out. Clean up any damage to the stems with a fine stone, and pull the valves out of the cylinder heads from the inside. Do not let the valves strike the cylinder wall when removing them. Valves and valve springs are to be placed in suitable racks having positions numbered for each cylinder. This will insure that the parts are reassembled in the same positions from which they were removed.

l. Remove Exhaust Elbows. Remove lock wire, nuts, and flat washers from the exhaust elbow hold-down studs, and remove the elbows (fig. 71). Use a special wrench (41-W-1471) to remove the nuts.

m. Cylinder Parts. No other parts will ordinarily be removed from the cylinders. Should inspection disclose the need for removing additional parts, the procedures outlined under repair instructions for this unit will be followed.

19. CLEANING THE MAIN SECTION.

a. Wash Crankshaft. The crankshaft journals are hollow and have plugs in the ends to provide oil reservoirs. The hollow chamber in the master rod journal will normally collect a considerable amount of sludge from the oil due to the centrifugal action of the rotating

R975-C1 ENGINE (CONTINENTAL)

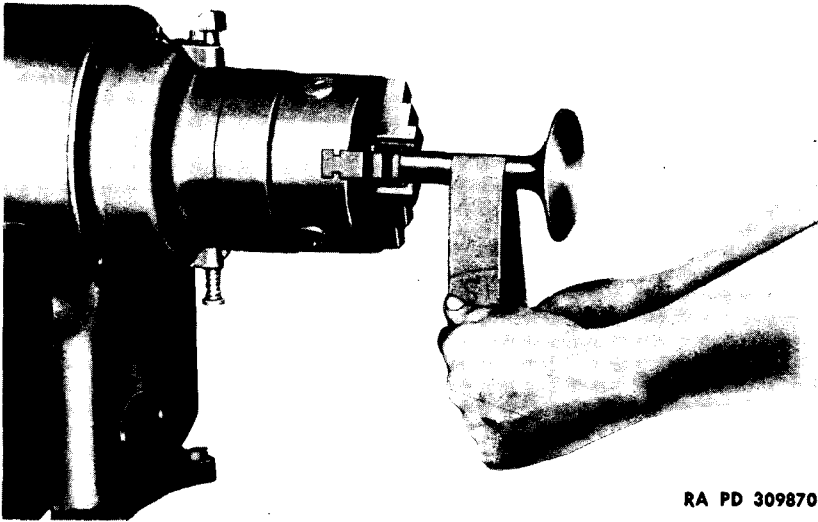

RA PD 309870

Figure 72 — Polishing Valve Stem

crankshaft. At each overhaul, the plugs should be removed (par. 18 c) and the sludge cleaned out. Use a small knife blade to loosen and scrape away the accumulated deposits, exercising care to avoid damaging the antisludge standpipe.

b. Clean Cylinders. The inside of the cylinder head may be sandblasted to remove the carbon and permit a thorough inspection of the surface. Spark plug bushings should be protected by inserting small rubber stoppers in the threaded holes. The rubber stoppers should be installed from the inside of the barrel. Unless it is known in advance that the valve seat inserts will be reground, they should be protected by using a set of discarded valves. If the seats are to be refaced, it may be desirable to sandblast them, since this cuts the carbon or glaze that may load up the grinding wheel. The ends and insides of the valve guides will be protected with rubber stoppers before sandblasting the seats. When the inside of the exhaust port is sandblasted, the valve guide should be protected with a discarded valve.

c. Clean Valves. The electrolytic method of cleaning valves is quick and effective. In this method, the valves are suspended in a melted mixture consisting of 60 parts of sodium hydroxide to 40 parts of caustic soda (sodium carbonate). Current is passed through each valve at the rate of 6 amperes for from 5 to 10 minutes, and is then reversed for approximately 10 seconds. Valves should be removed with brass lined tongs and allowed to cool; then washed in warm water,

**ORDNANCE MAINTENANCE — 9-CYLINDER, RADIAL, GASOLINE ENGINE
(CONTINENTAL MODEL R975-C1)**

dried, and brushed with a soft, fine wire brush. This method of cleaning shows up the real condition of the surface and prepares the valves for a rigid inspection. Where electrolytic cleaning equipment is not obtainable, the valve heads may be cleaned by grit blasting. However, it is necessary that the stems be well protected before starting to clean by this method. Carbon glaze may be removed from the stems by polishing with a strip of crocus cloth while spinning the valve in a grinder chuck (fig. 72). *CAUTION: Valves should never be cleaned with a harsh wire wheel or brush, as it will almost certainly damage the high finish.*

d. **Clean Front Main Bearing.** The front main bearing will be cleaned in a separate container from other engine parts. Use clean dry-cleaning solvent, kerosene and refer to the instructions contained in paragraph 9 c.

e. **Clean Pistons.** Do not immerse pistons in any compounds designed to remove hard carbon. Glazed surfaces of the piston skirts are not to be disturbed unless for removal of scratches. Carbon removing compounds destroy the glazed surfaces, and, for that reason, are not to be used. Removal of carbon deposits from the piston ring grooves shall be accomplished with greatest care. There is a small radius between the bottom of each ring groove and the ring lands. Even very light scratches on the surface of this radius seriously weaken the ring land. Suitable hand scrapers may be used to remove the carbon, but the sharp corners should be accurately rounded to preserve the radii in the bottom of the grooves. Piston heads may be cleaned of hard carbon deposit by sand blasting, provided a fine grade of sand is used and the air pressure kept below 30 pounds per square inch. Under no conditions is crushed shot, carborundum, or a coarse grade of sand to be used for cleaning any aluminum alloy parts. The piston pin bores and the sides of the piston should be well protected from damage. Plug the pin bores, and cover the entire outside diameter of the piston with tape or rubber tubing. Use every precaution not to increase or damage the small radius at the edge of the piston head. Carbon lodged in the oil drain back holes will be cleaned by reaming with an undersize drill.

20. INSPECTION OF THE MAIN SECTION.

a. **Inspect Intake Pipes.** Examine the intake pipes for any damage or defect which might cause leakage. Cracked or mutilated pipes are to be replaced. It is important that a perfect seal from the diffuser outlets in the crankcase rear section to the cylinder intake ports be maintained, as the fuel-air mixture carried therein is highly combustible. Leakage of the combustion mixture constitutes a serious

R975-C1 ENGINE (CONTINENTAL)

fire hazard, and every precaution should be taken to guarantee prevention of any difficulty of this nature.

b. Inspect Air Deflectors. Examine all deflectors to see that rivets are tight, toothed fasteners in good condition, and sheet metal not cracked or dented excessively.

c. Inspect Primer System. Examine condition of the threads on the primer tube fittings, and inspect the tubes for dents, cracks, or sharp bends. Check tightness of the fittings on the tubes.

d. Inspect Wiring Harness. At each engine overhaul, all wires in the ignition harness will be removed from the radio shielded conduits and discarded. It is considered good practice, however, to apply a standard high voltage test before the harness is disassembled. In this manner, it can be determined whether the harnesses are holding up well between regular engine overhaul periods. When the electrical test has been completed and all wires removed and discarded, the remaining conduits and shieldings should be carefully inspected. Check brazing closely for cracks, especially around the outlets and at the harness supporting brackets. There should be no dents in the manifold. Examine the terminal elbows closely for kinks or damage caused by improper use of assembly or repair tools. Inspect the wire braid shieldings for abrasions. Any worn conduits or spark plug connectors should be replaced. See that the harness supporting brackets are in good condition. Check condition of the threaded connectors on the spark plug leads and on the main conduits.

e. Inspect Oil Sump. Inspect the oil sump for cracks, particularly at the mounting flange locations. See that finished surfaces are true and will provide a good oil seal. Cleanliness is important; see that the sump has been cleaned free of all sludge and foreign material. Test the drain plug against a piece of steel for magnetism. Some magnetic plugs were not identified during manufacture. If one of these is found, stamp a letter "M" on the top face of the square end of the plug. If a nonmagnetic plug is found, replace it with a magnetic one.

f. Inspect Exhaust Manifolds. Mounting flanges should be flat, and there must be no cracks in the manifolds. Inspect for burned sections or evidence of excessive rusting. Check all clamps and bolts carefully for cracks or breakage.

g. Inspect Rocker Box Covers. Inspect all rocker box covers for warping of the parting surfaces, for cracks, and for burrs.

h. Inspect Rocker Arms. Inspect the roller for flat spots, chipped edges, cracks, and pitting (fig. 74). Look for evidence of interference between the rocker arm and the valve spring upper washer. This may be noted by scratches, nicks, or chafe marks on the lower

**ORDNANCE MAINTENANCE — 9-CYLINDER, RADIAL, GASOLINE ENGINE
(CONTINENTAL MODEL R975-C1)**

side of the rocker arm roller forks. Check wear of the roller on the hub (maximum 0.005 inch loose). Examine the ball socket of the adjusting screw for wear, nicks, or burs. See that the oil hole in the socket, and in the rocker arm are clean. Remove the roller bearings, using the plug and collar (41-P-2116), and inspect for roughness or damage. With the roller bearings removed, magnaflux inspect the rocker arm for cracks. **CAUTION:** *It is important that the bearing be removed before making the magnaflux inspection and that the rocker arm be thoroughly cleaned of all magnaflux test fluid after completing the inspection.*

i. Inspect Push Rods. Check rods for alinement by rolling on a surface plate. Do not attempt to remove ball ends for any reason. Examine ball sockets for wear or pitting and see that they are tight in the rod.

j. Inspect Push Rod Housings. Remove all hose connections and discard at each overhaul. Bent or damaged hose clamps should also be replaced. It is important that the push rod housing provide a good oil seal from the rocker box to the tappet retainer in the crankcase main section. Therefore, examine the housing closely for cracks, dents, or irregularities that might cause oil leakage.

k. Inspect Valves. Make a visual inspection of the valve faces to determine whether or not they are seating properly. Warped valves will show areas over which the face is not contacting the seat. This may be indicated by heavy discoloration, burning, or erosion of the material, or by the accumulation of carbon. Light frosting or discoloration of the shiny face in certain areas should not be cause for any particular concern if the valve otherwise appears in good condition. It is entirely possible that such evidence of difficulty is not deposited until after stopping and the valves begin to cool to the same temperature as the rest of the engine. Examine the stems and the lock grooves for wear, scores, pitting, or other damage (fig. 73). See that the tips are not cracked or excessively worn. **NOTE:** *Exhaust valves are not to be examined for cracks by the magnetic type of inspection. Do not magnaflux test exhaust valves. Bury old sodium-filled exhaust valves in the ground to avoid possible fires or injury to personnel. Never include sodium-filled valves with other parts turned in for salvage or disposal as scrap.*

l. Inspect Valve Springs and Washers. Valve springs should be examined individually for breakage. Broken spring tips at the flat grind, if not for more than $\frac{1}{2}$ inch length, are not cause for replacement. The springs should be tension tested in any of the commonly used testing machines. Refer to items 9, 10, and 11 in the Table of

R975-C1 ENGINE (CONTINENTAL)

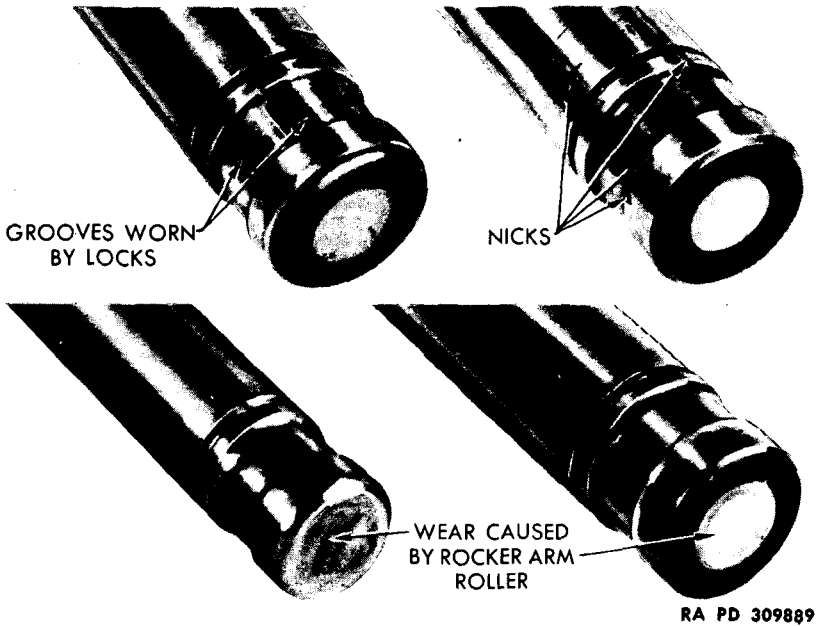

Figure 73 – Valve Stems, Worn and Damaged in Service

Limits for specifications. Check washers for indications of wear or fatigue at the seat for the two tapered valve retaining keys. This may be noted by observing whether the split keys have actually worn into the seat. Since the keys are split, they do not contact the retainer all the way around, and a ridge will be left where no wear has occurred.

m. Inspect Valve Tappets, Rollers, and Ball Sockets. Valve tappets should be examined for wear or scoring. Close tolerances are maintained on the fit between the tappet and the guide. It is important that the clearances of no more than 0.003 inch be maintained to prevent excessive oil passage around the tappets instead of into and through the push rod. Inspect the rollers for flat spots, chipped edges, cracks, and pitting (fig. 74). See that the pins are not worn excessively (maximum 0.006 inch loose). Examine the ball sockets for wear, nicks, or burs.

n. Inspect Cylinders.

(1) **INSPECT CYLINDER BORE.** Examine the surface condition of the bore for deep scratches, scuff streaks, or “bluing” due to excessive temperatures. The amount of wear, or ridge, at the end of the piston ring travel can be measured, using any of the devices commonly employed for that purpose (fig. 75). Replace cylinder assembly if the

**ORDNANCE MAINTENANCE — 9-CYLINDER, RADIAL, GASOLINE ENGINE
(CONTINENTAL MODEL R975-C1)**

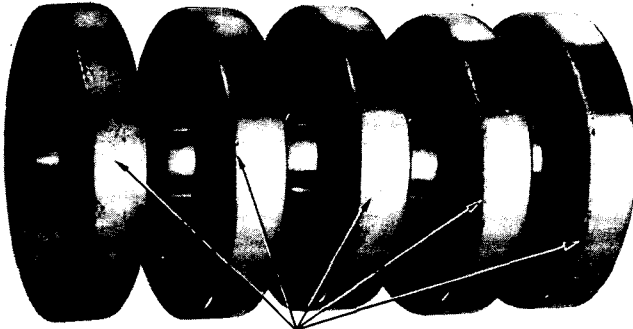

NOTE PITS IN CASE HARDENED
CONTACT SURFACE

RA PD 309887

Figure 74 — Valve Tappet Rollers

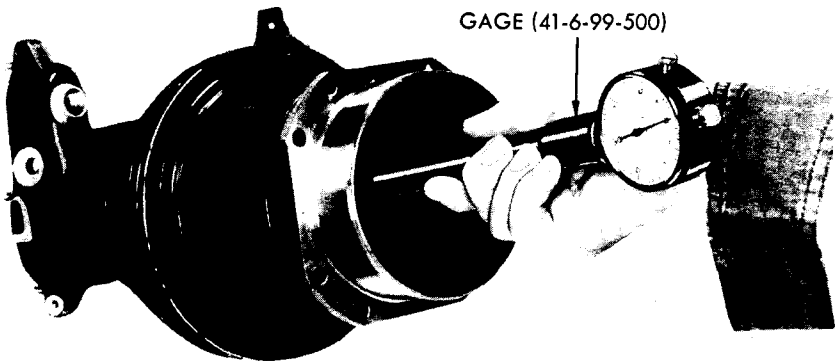

Figure 75 — Checking Cylinder Bore for Wear RA PD 336200

diameter at the flanged end exceeds 5.008 inches, or if there is less than 0.005 inch choke at the head end of the bore. Permissible out-of-round is 0.002 inch. Light red or orange colored patches that may sometimes be found on the cylinder wall can be caused by spark plug lubricant, or they may be rust. Using a small inspection mirror and a suitable light, carefully examine the head and barrel connection for evidence of erosion at that point. Any indications of this difficulty will be cause for replacement of the cylinder assembly. If there is excessive carbon deposit in the head, it is to be cleaned before inspecting the head and barrel connection for erosion.

(2) **INSPECT VALVE SEAT INSERTS.** The inserts must show no signs of loosening in the cylinder head. Carefully inspect the condition of the valve seats for pitting, burning, or evidence of poor seating of the valves.

R975-C1 ENGINE (CONTINENTAL)

(3) **INSPECT INTAKE AND EXHAUST PIPE MOUNTING FLANGES.** Carefully examine the intake and exhaust flanges for nicks, burs, erosion, or burning. Try studs for security, and see that threads for the nuts are in good condition.

(4) **INSPECT SPARK PLUG INSERTS.** Spark plug inserts should show no indications of turning in the head. Examine condition of the threads.

(5) **INSPECT VALVE GUIDES.** Inspect the inside for excessive carbon deposit, and clean out with crocus cloth and gasoline if necessary. Examine guides for looseness in the heads, cracks, and galling or scuffing of the inside surfaces. Measure maximum wear, using tapered parallel gages and a 1-inch micrometer. Maximum clearance between valve stem and inside diameter of guide is 0.005 inch on the intake and 0.008 inch on the exhaust.

(6) **INSPECT MOUNTING FLANGE.** Check the cylinder base mounting flange for scoring by the hold-down nuts. Examine both sides of the flange carefully for scratches. Even small scratches at the flange aid in the start of fatigue cracks, which, in this instance, would seriously affect engine operation.

(7) **INSPECT FINS.** Carefully check for cracked or damaged fins on the cylinder head. It is permissible to rework cracked or broken fins by profiling to the depth of the crack, provided the crack does not extend into the dome of the cylinder head, and provided only a small amount of fin metal is removed. Replace any cylinder in which a fin crack is found to extend into the cylinder head dome, or in which an appreciable area of the fin metal must be removed to make the repair.

o. Inspect Pistons.

(1) **CHECK RING GROOVES.** Examine the pistons for excessive scoring or scratching of the skirts. If sticking of any rings was noted before cleaning, find out whether or not this was caused by bent lands on the piston. First determine that all carbon is cleaned from the grooves, and then measure the side clearance between a standard size ring and the land. In determining the side clearance, measurements will be taken at several places around the piston. Say, for example, that normal side clearance is 0.007 inch and an area is found with feeler gages where it is only 0.003 or 0.004 inch. Then check the next ring above or below in the same area and note, possibly, that the clearance may be found to be 0.010 or 0.012 inch. This would indicate that the ring land between the two grooves is in all probability starting to bend or break. Any such indications are cause for immediate rejection of the piston. No attempt will be made to repair the piston in order to obtain desired side clearance.

**ORDNANCE MAINTENANCE — 9-CYLINDER, RADIAL, GASOLINE ENGINE
(CONTINENTAL MODEL R975-C1)**

Normal side clearance of the piston rings is as follows:

Top	0.0055 – 0.007	inch
Second	0.004 – 0.0055	inch
Third	0.0025 – 0.004	inch
Fourth	0.0025 – 0.004	inch
Fifth	0.0025 – 0.004	inch

(2) **INSPECT RING LANDS.** Determine that ring lands are not rubbing heavily on the cylinder barrel or starting to erode due to high temperatures of the combustion mixture. Bright spots, especially on the top land, should not necessarily be cause for alarm. They are usually caused by rubbing against carbon deposited in the head. So long as there are no definite appearances of metal-to-metal contact, the piston may be expected to continue satisfactory operation with no difficulty from this source.

(3) **INSPECT PISTON PIN BORES.** Measure diameters to determine fit of the piston pin in the piston pin bore. The pins and bores may be cleaned using crocus cloth wet with gasoline. The pin bores are to be checked for wear (maximum 0.003 inch loose) and concentricity.

(4) **INSPECT OIL DRAIN BACK HOLES.** See that oil drain back holes are clear. There must be no accumulation of burned carbon.

(5) **CHECK WEAR.** Measure piston skirt diameters for wear (maximum 0.035 inch loose at center of skirt).

p. Inspect Piston Pins. Inspect the piston pins for scoring, cracks, excessive wear (maximum 0.003 inch loose in piston and 0.005 inch loose in rod bushing), and pitting.

q. Inspect Articulated Rods.

(1) **INSPECT BUSHINGS.** Examine the piston pin bushing carefully for cracks, scoring, burning, or excessive wear (maximum 0.005 inch loose on pin). Try piston pins and knuckle pins for fit to see that they are free in the rod bushings. Carbon deposit may be removed from the bushings, using crocus cloth wet with gasoline. After removal of the carbon, recheck the bushing for cracks.

(2) **INSPECT ROD.** Inspect the rods for cracks, scratches, nicks, burs, and bending. Do not attempt to straighten a bent or misaligned connecting rod, no matter how slight the amount of bend. If alignment is not within the specifications outlined below, discard the connecting rod, and replace with a new part. To check alignment, proceed in the following manner: Select the bar (41-B-263) to fit the piston pin bushing bore, and insert in the connecting rod. Then select the bar (41-B-19-600 or 610) to fit the knuckle pin bushing bore, and insert in the rod. Install the connecting rod in the alignment

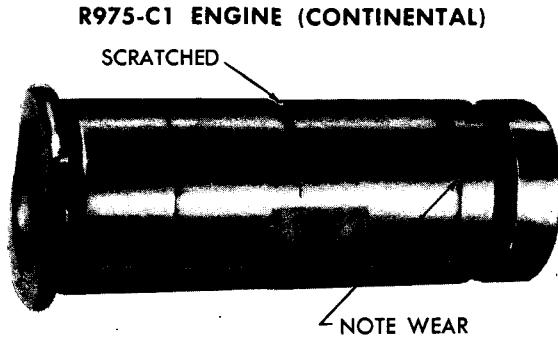

RA PD 309897

Figure 76 – Articulated Rod Knuckle Pin

checking stand (41-S-4977) by resting the bar which passes through the piston pin bushing hole on the “V” blocks of the fixture. This will permit the rod to hang freely. To check for twist, measure the clearance between one end of the bar, which is inserted through the knuckle pin bushing bore, and the corresponding rail of the fixture, when the other end of the bar is contacting the other side rail (fig. 77). The amount of twist, determined in this manner, should be no greater than 0.0045 inch. The method of this inspection for the master connecting rod is illustrated in figure 77. To check alignment, support a dial indicator on a surface gage, and measure the height of the knuckle pin bar at each end. The total difference between the two readings obtained in this manner should be no greater than 0.0045 inch (fig. 78).

r. Inspect Knuckle Pins. Examine the knuckle pins for cracks, galling, and condition of the flanges. See that the oil passages are clear. Check tightness of the plug in the antifranged end of each pin, as this plug seals the oil passage. Check fit of the knuckle pins in the master (maximum 0.0015 inch loose) and articulated (maximum 0.004 inch loose) connecting rods. See that the bearing surface is not abnormally scratched or damaged (fig. 76).

s. Inspect Master Connecting Rod and Bearing.

(1) **INSPECT ROD.** The inspection procedure outlined for articulated connecting rods will also be applied to the master rod. Alignment will be checked using the same fixture and the same piston pin bushing bore bar. Install bar (41-B-263-29) in the bearing bore and proceed as previously outlined (figs. 77 and 78). A maximum of 0.0045 inch allowable twist or misalignment, as determined by this method, is acceptable. No attempt will be made to straighten a bent connecting rod. If misalignment exceeds permissible limits, replace with a new connecting rod.

ORDNANCE MAINTENANCE — 9-CYLINDER, RADIAL, GASOLINE ENGINE
(CONTINENTAL MODEL R975-C1)

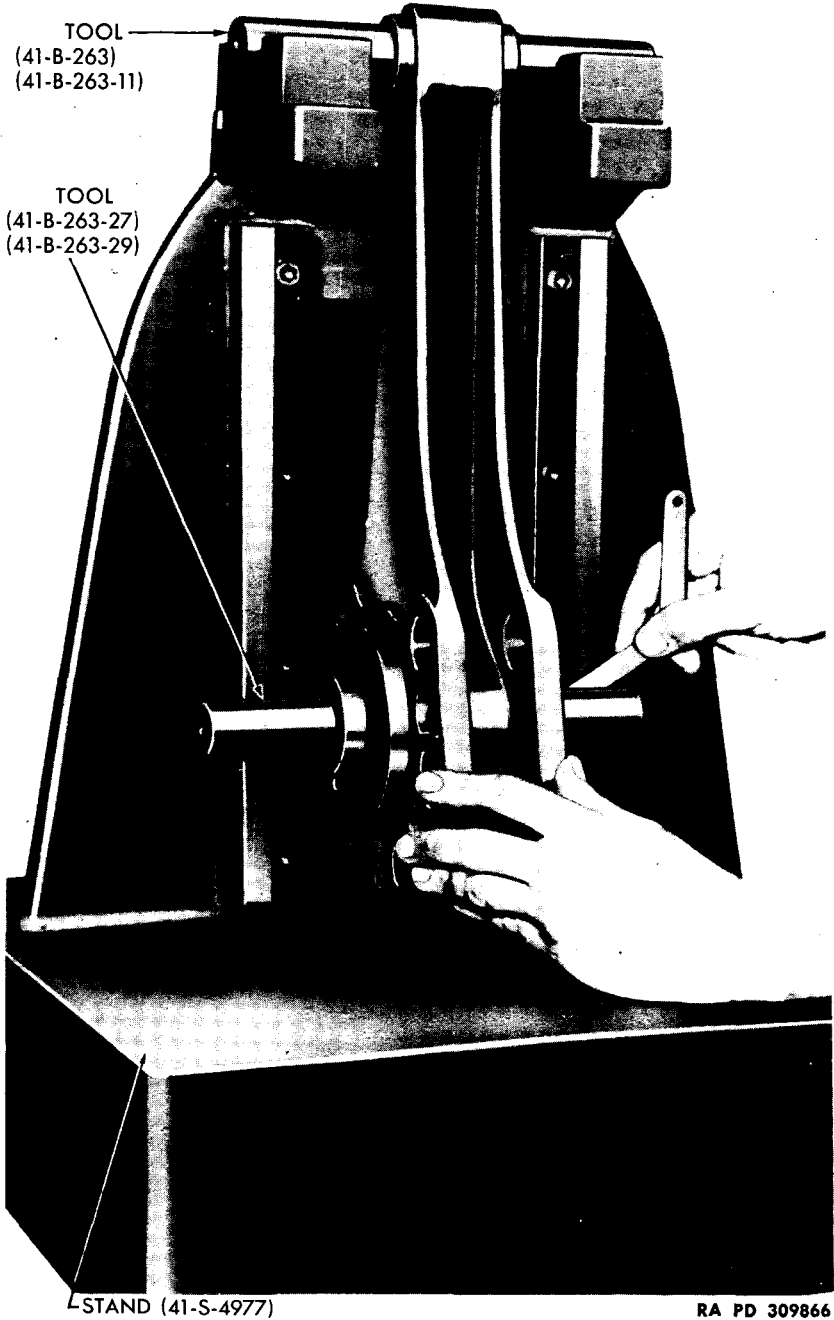

Figure 77 — Checking Master Rod for Twist

R975-C1 ENGINE (CONTINENTAL)

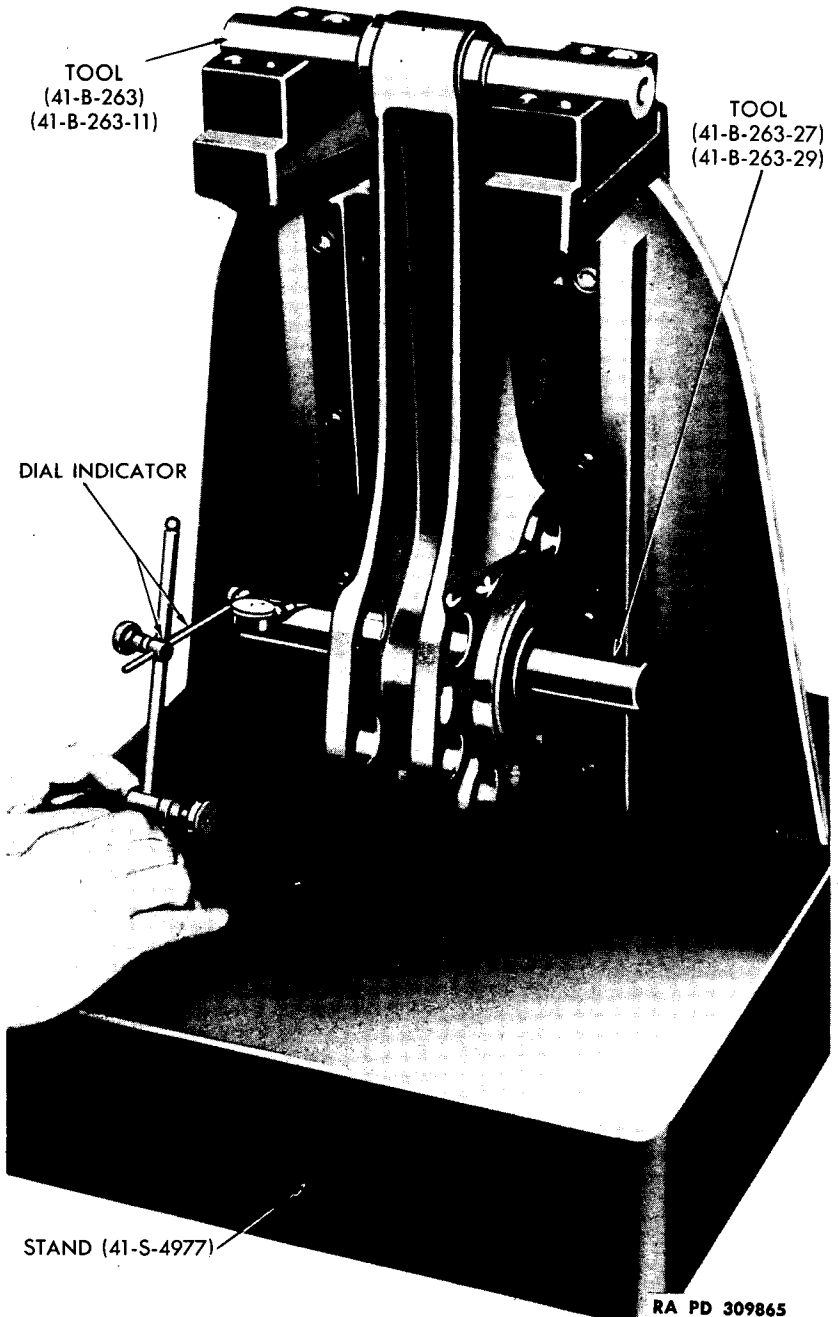

Figure 78 – Checking Master Rod Alinement

**ORDNANCE MAINTENANCE — 9-CYLINDER, RADIAL, GASOLINE ENGINE
(CONTINENTAL MODEL R975-C1)**

(2) **INSPECT KNUCKLE PIN HOLES.** Inspect the knuckle pin holes for evidence of galling, ridges, scoring, and cracks. Check fit of the knuckle pins in the knuckle pin holes (subpar. r above), measurements to be taken after any necessary polishing operations. See that the flanges on the master rod have not been damaged by removal or installation of the knuckle pins.

(3) **CHECK BEARING WEAR.** Check inside diameter of the master rod bearing and compare with the crankpin journal diameter to determine the amount of clearance. Clearance must be within the maximum limit of 0.006 inch, or the bearing is to be replaced. Check inside diameter of the bearing and outside diameter of the crankpin in several different locations, and use the average of values obtained thereby to determine the average amount of clearance.

(4) **INSPECT BEARING CONDITION.** In the examination of master rod bearings, a difficulty known as "hen tracking" may be observed. This is a form of incipient corrosion and consists of a closely knit group of interconnected furrows. Where this condition is found, and is confined to small well defined areas, not greater than ½ inch square in extent, the bearing may be continued in service. Where the "hen tracking" is extensive or shows signs of spreading all over the surface, the bearing should be replaced. In addition to an inspection of the surface condition for this difficulty, the bearing should be closely examined for cracks, scoring, overheating, flaking, high spots, and foreign material.

t. Inspect Crankcase Main Section.

(1) **INSPECT CASTING.** Examine the entire crankcase main section very carefully for cracks. Use a strong light and check over thoroughly. Even small cracks would probably lead to greater difficulty during subsequent operation of the engine. Scrap any crankcase main sections in which cracks are found.

(2) **CHECK STUDS.** See that all cylinder base studs are tight in the flanges. Each stud is to be tried with a stud driver. Check for any evidence of stretching or cracking at the necked section between the two threaded ends. All threads must be in good condition.

(3) **INSPECT MOUNTING FLANGES.** Closely inspect all mounting flanges for nicks or burs. Cylinder pads, front main bearing support flange, diffuser section flange, and other machined mounting flanges must be smooth and in good condition. Oil leaks are difficult to eliminate if these surfaces are damaged in any manner, either by careless handling or improper use of overhaul tools. If all flanges are in good condition and oil leakage starts or continues, check the flanges on a surface plate for warpage.

(4) **INSPECT CYLINDER HOLES.** See that cylinder holes in the

R975-C1 ENGINE (CONTINENTAL)

crankcase have not been dented or damaged by allowing connecting rods to swing after the cylinders were removed.

(5) **TEST OIL LINES.** Test oil lines to see that all are open. This may be done by flowing dry-cleaning solvent through the lines. Insert dry-cleaning solvent through the hole in the left-hand side of the rear parting flange. If necessary, stop all passages except the one being tested by placing the fingers over the outlets.

u. Inspect Crankshaft Front Main Bearing. Carefully inspect the front main bearing rollers and races with a magnifying glass for flat spots, cracks, or a pitted condition of the surfaces. The presence of any of these conditions will warrant replacement. Bearings are not to be inspected by the magnetic method of inspection. However, since bearings in normal operation tend to pick up a certain amount of magnetism which will hold small magnetic parts and increase wear, it is necessary that they be demagnetized. Therefore, after cleaning and inspecting the front main bearing, it is to be thoroughly demagnetized. This will be accomplished by passing through the demagnetizing coil of a magnetic type inspection machine. Reclean the bearing, pack with petrolatum, and wrap in clean, oiled paper until ready for assembly.

v. Inspect Crankshaft Rear Main Bearing. Inspection instructions outlined in paragraph 20 s (3) and (4) for the master rod bearing will be applied to the crankshaft rear main bearing. See that the bearing is tight in the main section and that threads for the cam hub bearing support are in good condition. Measure bearing diameter in several different places and compare with the average crankshaft rear journal diameter (maximum clearance 0.0055 inch).

w. Inspect Front Crankshaft.

(1) **REMOVE THRUST SPACER.** The master rod bearing thrust spacer must be removed to permit magnetic type inspection of the fillet at the crankpin shoulder. Since this spacer is shrunk on to the crankpin, a particular technique is required to accomplish its removal. The above spacer may be loosened a sufficient amount to remove by pouring oil heated to 300° to 400°F over the outside of the spacer. Hold the crankpin in a horizontal position, and pour heated oil slowly down the groove on the outside surface of the spacer. The spacer may then be removed by hand, using a cloth or asbestos gloves as protection for the hands. Attempts to remove the spacer in any other manner may result in damaging the crankpin by marking or scratching.

(2) **INSPECT SURFACE CONDITION.** Inspect the crankshaft front end for cracks. Carefully examine all surfaces for scratches, nicks, and scores. Examine the crankpin for burs, scores, and galling, par-

**ORDNANCE MAINTENANCE — 9-CYLINDER, RADIAL, GASOLINE ENGINE
(CONTINENTAL MODEL R975-C1)**

ticularly in the location of the crankpin oilhole and the fillet at the front end of the crankpin. Inspect the crankpin for evidence of overheating. Check for out-of-round condition at both front and rear of the crankpin. Diameters in each case are to be measured in two locations 90 degrees apart. Inspect the clamping surface at the rear of the crankpin for scores, burs, galling, and evidence of turning of the crankshaft rear end on the crankpin.

(3) **INSPECT SPLINES.** Examine the flywheel hub splines closely. Check condition of the flywheel hub cone journals and the flywheel hub retaining nut clevis pin holes. Inspect the splines for nicks and wear. Examine the flywheel hub retaining nut for burs, cracks, and condition of the threads.

(4) **INSPECT BEARING LOCATIONS.** Inspect the front main bearing and thrust bearing locations for galling, and check fit of the bearings on the crankshaft (front main 0.0002-0.0007 inch tight, thrust bearing 0.0002 inch tight to 0.0009 inch loose). Observe condition of the front crankcheek and extension, and check the counterweights for tightness of the rivets. Examine condition of the threads in the tapped hole which receives the crankpin bore plug retaining cap screw. See that all sludge deposits have been removed from the crankpin bore. Check the oil nozzle, or stand-pipe to determine that it has not been damaged and is free from dirt and sludge. Inspect the thrust bearing nut for burs, cracks, and for condition of the threads and oil seal ring grooves. Replace the thrust nut at each overhaul. Check the new oil seal rings for proper side clearance (0.002-0.010 inch).

(5) **INSPECT LOCK NUT.** Inspect the front main bearing lock nut for burs, cracks, and condition of the threads. Check the spacer for roughness and burs.

x. Inspect Rear Crankshaft.

(1) **MAGNAFLUX PARTS.** Inspect the crankshaft rear end for cracks by the magnetic method. Carefully examine all surfaces for scratches, nicks, and scores. Check the inside diameter of the crankpin hole for scratches, burs, and chafing. Examine threads in the cap screw hole for indications of pulling, and check the inner clamping surface for burs. Magnaflux the cap screw for cracks and check for burs. Check the cap screw washer for burs, cracks, and proper seating at the cap screw head.

(2) **INSPECT BEARING JOURNAL.** Check the rear main bearing journal for wear, grooving, or roughness. Diameters are to be measured in several different places and an average taken to determine the diameter for comparison with the rear main bearing bore (maximum

R975-C1 ENGINE (CONTINENTAL)

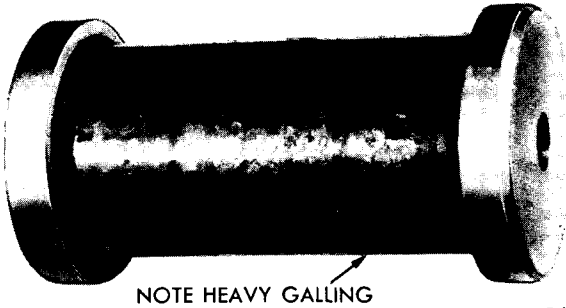

RA PD 309893

Figure 79 – Rear Counterweight Pin

0.0055 inch loose). Very fine surface marking on the bearing journal can be polished over if a new bearing is being installed. A dimensional check is to be made after polishing. See that oil passages are clear, and rear crankshaft gear retaining screw threaded holes are in good condition.

(3) **INSPECT DAMPER PIN BUSHINGS.** Check the dynamic damper pin bushings for tightness in the crankcheek. Examine the bushings for cracks, scores, wear, and out-of-round. Inspect the dynamic damper stop for nicks, burs, and cracks. Check the stop retaining bolts and nuts for burs and condition of the threads. Inspect the dynamic damper weight for burs and roughness. Check the pin bushings for tightness in the weight, cracks, scores, and out-of-round. Examine the pins for cracks, roughness, wear, galling, condition of the flanges, and out-of-round (fig. 79).

y. **Inspect Rear Crankshaft Gear.** Examine the gear teeth for chipping, pitting, or wear of the case hardened contact surfaces. There should be no evidence of improper contact with the mating gears. Examine the lugs for nicks and burs. Check the hub to see that it is not cracked. Check springs for cracks, and the pins for burs.

z. Inspect Cam and Cam Drive Gear.

(1) **INSPECT CAM.** The cam is one of the most accurately machined parts in the engine. Carefully inspect the cam lobes and tappet roller tracks for wear or scuffing (fig. 80). No attempt should be made to stone out and smooth over normal and even wear on the lobes. Light scuffing of the lobes may be removed with a very fine stone, but no further repairs are to be attempted. Examine the external gear teeth on the cam for pitting, chipping, or excessive wear.

(2) **INSPECT CAM HUB BEARING.** Check the cam hub bearing bore for scores, scratches, or burs. See that the bearing is tight in the hub. Compare clearances between the bearing bore and the cam hub bearing support outside diameter (maximum 0.008-inch

**ORDNANCE MAINTENANCE — 9-CYLINDER, RADIAL, GASOLINE ENGINE
(CONTINENTAL MODEL R975-C1)**

NOTE—CAM STARTING TO PIT

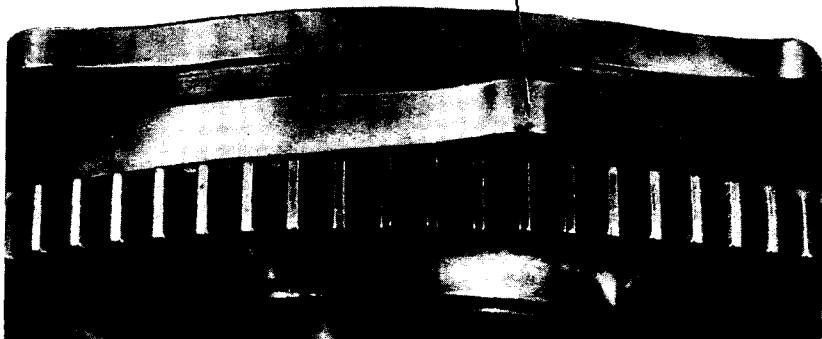

NOTE—BOTH CAMS HEAVILY PITTED

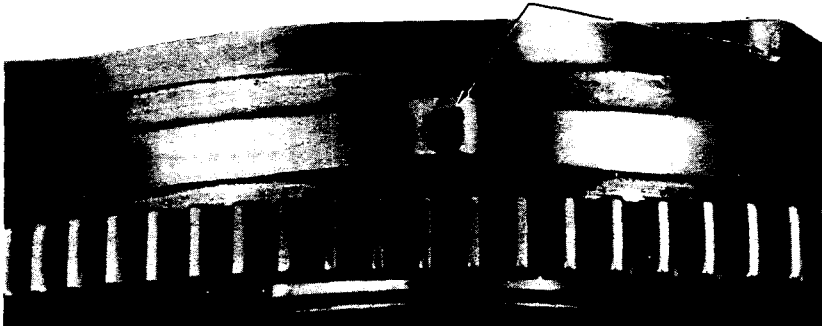

RA PD 309888

**Figure 80 — Cam Assemblies — Showing Pitted Condition of
Roller Tracks**

clearance). Diameters should be checked in four or five different places and averaged.

(3) **CHECK CAM BOLTS.** On early R975-C1 engines, the cam was fastened to the hub by means of bolts. Beginning with engine serial number 309485, a new cam assembly became effective and is available for replacements on previous engines. This new cam may be identified by noting that rivets are used to fasten the cam to the cam hub. Check the cam hub bolts or rivets, whichever are used, to be sure they are tight. Loose bolts or rivets will necessitate replacement of the entire cam and hub assembly. Never separate the hub from the cam ring.

(4) **INSPECT CAM HUB SUPPORT.** Examine the cam hub support threads for burrs. See that the outside diameter, or bearing surface, is smooth and free from nicks, burrs, or scratches. Check the cam hub bearing spacer for burrs, roughness, and uniform thickness.

R975-C1 ENGINE (CONTINENTAL)

21. REPAIR OF THE MAIN SECTION.

a. Repair Intake Pipes. Intake pipes that are not too severely damaged may be straightened. Back up the part to be straightened with a metal rod of the proper size and shape. Be careful when hammering out dents that the wall thickness is not reduced materially or cracked. Repaint the pipes if necessary. Slight nicks or dents on the flanged ends of the pipes, or on the flanges themselves, may be removed on a lapping block. Minor cracks on the flanges may be repaired by welding. Replace any pipes that are badly cracked. Replace any packing nuts that are bent or have damaged threads.

b. Repair Air Deflectors. Hammer out any dents in the air deflectors, being careful not to reduce the wall thickness appreciably. Drill out loose rivets and replace with new ones. Cracks on the deflectors may be welded if they are not located adjacent to rivets. Brackets or fasteners which are broken or mutilated should be replaced. Repaint deflectors, if necessary, after repairs have been completed.

c. Repair Primer System. Do not attempt to repair any part of the priming system. Damaged or defective parts that are unsatisfactory for further use will be replaced with new parts.

d. Repair Wiring Harness.

(1) **SOLDER TUBING.** Any cracks or loose joints in the tubular manifold housing will be repaired by torch soldering. High melting point silver solder will be used in making the repairs. As the high melting point of this solder requires the use of a torch, it is necessary that all ignition cable first be removed in order to avoid burning the insulation.

(2) **SOLDER BRAIDING.** Wire braiding that has pulled loose will be repaired by resoldering. Low melting point silver solder is to be used for repairing all of the flexible connections and braided portions of the harness. This solder will be applied with a soldering iron, properly heated. If damage other than loosening of the original solder is evident on any of the braiding, that section of the harness is to be replaced with new material. No attempt should be made to repair kinked, chafed, or dented flexible portions of the shielding.

(3) **REPLACE CONTACT SLEEVES.** Ignition contact sleeves are not to be used for reassembly of the harness if the spring is loose or broken. New parts will be used to replace those sleeves which have been cracked or burned.

(4) **DRESS THREADED PIPES.** Remove any burrs from the harness parts, and dress the threads in the outlets. A fine mill file can be used to advantage in the repair of ignition shielding.

**ORDNANCE MAINTENANCE — 9-CYLINDER, RADIAL, GASOLINE ENGINE
(CONTINENTAL MODEL R975-C1)**

(5) **REPLACE TERMINAL ELBOWS.** Replace any spark plug terminal elbows which are found to be dented or kinked. Under no circumstances will the terminal elbows be twisted or bent to alter their original angularity. Elbows on which the coupling nuts have cracked, or have had threads damaged, should be replaced.

(6) **REPLACE IGNITION WIRES.** All ignition wires are to be replaced at each overhaul of the engine, so no attempt will be made to accomplish repairs.

e. **Repair Oil Sump:** Damage to any of the flat machined surfaces will be cleaned up on a lapping block. Replace the strainer, spring, or cap screws if they are bent or mutilated.

f. **Repair Exhaust Manifold.** Small dents in the manifolds are to be removed, and any cracks repaired by welding. Thin sections that may be caused by rust or burning will be sufficient cause for replacement of the pipe. Lap or stone flanges to flatten sufficiently to provide a good seal.

g. **Repair Rocker Box Covers.** Covers that are cracked should be replaced. Nicks or burs on the machined parting flange may be removed on a lapping block.

h. **Repair Rocker Arms.**

(1) **REMOVE PIN.** Rocker arm rollers are removed by machining out the flanged end of the pin, and pushing the pin out of the forks. Use a 60-degree counter drill to machine out the flanged end.

(2) **INSTALL NEW ROLLER, HUB, AND PIN.** Select a new hub and a new roller to allow the specified clearance, and hold them in place centered with the drilled holes in the forks. Install a new pin, and drive in until the ends extend an equal distance on both sides of the arm. Hold the rocker arm with the pin resting on an anvil, and strike the upright end one hard blow with a hammer. Turn the arm over and strike the opposite end of the pin a second blow. This will swell the pin so that it fits tightly in the rocker arm forks and roller hub. Roll the ends of the pin in a rivet setter, and check to see that the roller is free on the hub. The hub is slightly wider than the roller, so the forks of the rocker arm will not be closed up on the roller when the pin is riveted.

(3) **REPLACE ROLLER BEARING.** Replacement of the hub roller bearing will be accomplished by pressing out the old bearing with rocker arm bearing removing plug and collar (41-P-2116) and installing a new one using heat and dry ice. Cool the new bearing in dry ice, and heat the rocker arm in oil to 250°F. Start the new bearing in the chamfered side of the bearing bore.

(4) **REPAIR ADJUSTING SCREWS.** Stone burs from the screw-

R975-C1 ENGINE (CONTINENTAL)

driver slot of the adjusting screw. Replace the screw if the ball socket is excessively worn, or if damage to the screwdriver slot is extensive.

i. Repair Push Rods. If the ball sockets fit loosely in the rod or if they are worn, replace with a new push rod assembly. Slightly bent push rods will be straightened by tapping lightly with a fiber hammer.

j. Repair Push Rod Housings. Straighten any housings that are not too severely dented. Ends of the housings should be smooth and well rounded to provide a good oil seal.

k. Repair Valves.

(1) **GRIND TIP.** Remove all nicks and burrs in the lock grooves by stoning with a fine stone. Wear or grooving of the tip, caused by the rocker arm roller, may be removed by grinding. Remove only the minimum amount of material necessary to provide a good contact surface for the roller. Break all sharp edges by stoning to at least a 0.010-inch radius before removing the valve from the grinding machine.

(2) **GRIND FACE.** The face angle on both valves is 44 degrees to 44 degrees 15 minutes. If inspection has indicated the need for reconditioning, this may be accomplished in any of the approved valve grinding machines. The grinding wheel on the machine must be properly dressed to make sure it is true and smooth. It is upon the condition of this wheel that the surface quality of the finished job depends. Secure the valve in the grinding machine chuck and take a very light cut on the valve face. If the wheel grinds the face on one side only, stop the machine and turn the valve halfway around in the chuck. Take another light grind and examine the cut made. If it still grinds the same side of the valve, the chuck is true, and grinding should be continued until the face is cleaned up and a good surface finish obtained. While the valve is still in the machine and turning, stone the sharp edges to provide a 0.010-inch radius. Use a fine stone, and be careful to keep off the newly ground valve face.

l. Repair Valve Springs and Washers. Valve springs on which the tips are broken off for more than $\frac{1}{2}$ -inch length, or which are weak when tension-tested, will be replaced. Washers will be replaced if indications of wear are noted upon inspection.

m. Repair Valve Tappets, Rollers, and Ball Sockets. Slight-irregularities in the tappets, rollers, or ball sockets may be polished out with crocus cloth. No other repairs are authorized.

n. Repair Cylinders.

(1) **REPAIR COOLING FINS.** If a cylinder fin is cracked parallel to the fin contour and does not go very close to the fin root, profile

**ORDNANCE MAINTENANCE — 9-CYLINDER, RADIAL, GASOLINE ENGINE
(CONTINENTAL MODEL R975-C1)**

to the depth of the crack. Cracks perpendicular to the fin contour may be removed by cutting a slot in the fin. The slots should be V-shaped and should be well rounded at both top and bottom. It will be necessary to use extreme care when profiling to avoid damage to adjacent fins. Remove all sharp corners and scratches when the work is completed.

(2) **REPAIR MOUNTING FLANGE.** A crack in the mounting flange will require replacement of the barrel. The cylinder assembly should be replaced and the old unit returned for repairs. Small nicks in the flange will be removed with a fine stone.

(3) **REMOVE VALVE GUIDE.** Valve guides will be removed by boring out until only a thin shell remains, and then collapsing the shell. Do not attempt to pull the guide, as this procedure may damage the cylinder head. If the bore in the cylinder head has not been damaged, and is smooth, a standard valve guide may be used for replacement. Otherwise, it will be necessary to ream the hole and install an oversize guide. Guides are furnished in oversizes of 0.005, 0.010, 0.020, 0.030 inch. Use the bushing (41-B-2032) in combination with a suitable size reamer, and clean any roughness or galling. Measure inside diameter of the finished hole, and select a valve guide to provide the proper amount of press fit (intake 0.001 to 0.0025 inch, exhaust 0.002 to 0.0035 inch).

(4) **INSTALL VALVE GUIDE.** Heat the cylinder in a flameless oven for 1 hour at 300°F. Chill the guide in dry ice for 20 minutes. Remove the cylinder from the oven, and insert the guide in such a position that the oversize markings (if any) stamped above the shoulder are toward the push rod end of the rocker box. Allow the cylinder to cool just long enough for the head to grip the guide. Then strike the end of the installation arbor a sharp blow with a hammer to insure that the guide is properly bottomed. Remove the arbor and allow the cylinder to cool. Ream the valve stem guide to size using the proper expansion reamer (41-R-494 for exhaust, or a suitable sized expansion reamer for the intake). Clean bores with crocus cloth, and check finished size of the guides to see that the clearance specified (intake 0.003 to 0.0035 inch, exhaust 0.005 to 0.0065 inch) will be provided. Always reface valve seats after installing new valve guides.

(5) **REPAIR VALVE SEAT INSERTS.** The surface contacting the valve face may be reconditioned by grinding, but no provision is made for replacement of the insert. Notify the proper authority if replacement is necessary.

R975-C1 ENGINE (CONTINENTAL)

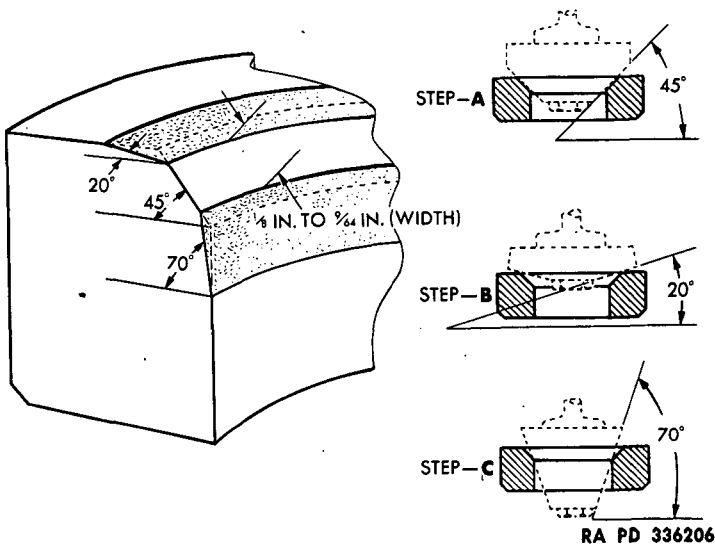

Figure 81 – Valve Seat Insert Angles for Reconditioning

(6) RECONDITION VALVE SEATS.

(a) *Check Seats.* The valve seats will be refaced by grinding whenever they are burned, pitted, show evidence of misalignment with the valve stem guide, or when new guides are installed. Both inserts are made from durable materials which normally will require very little reconditioning. Small and isolated dark spots on the seating area, especially if they are not located at the edge, should not ordinarily be sufficient cause for reconditioning the seat.

(b) *Clean Guides.* Before reconditioning seats, remove all carbon and dirt from the inserts and the valve guides. Special care should be taken to see that the valve stem guide is cleaned out thoroughly. The grinding operation depends for its accuracy upon a pilot in the valve guide. Any foreign material or guide distortion will prevent proper seating and centering of the pilot.

(c) *Dress Grinding Wheels.* Wet grinding equipment is to be used whenever possible. Three different stones will be necessary to complete a satisfactory reconditioning job. On both inserts, the seating area is a 45-degree angle off the valve head center. Both seats may be narrowed down when necessary with a 20-degree wheel across the top and a 70-degree wheel in the valve port (fig. 81). Grinding wheels should be dressed down before commencing any

**ORDNANCE MAINTENANCE — 9-CYLINDER, RADIAL, GASOLINE ENGINE
(CONTINENTAL MODEL R975-C1)**

valve seat job and after grinding each bronze seat if the metal has "picked up" on the wheel.

(d) *Grind Seats.* Install the grinder in position, and take a very light cut to remove the surface glaze from the seat. Always use the 45-degree wheel first. While throwing the grinder motor starting switch, the torque handle on the machine should be held securely to prevent the starting reaction from throwing the grinder body against the cylinder wall. Special care in feeding the grinder is necessary at the start until the high side of the seat is found. After each time the wheel is fed in, allow the grinder to cut itself free before feeding again. This will be the simplest way to avoid burning the seat, and a good finish should be obtained. Do not remove any more material than is required to clean the seat all the way around. Small isolated dark areas in the center of the seat should do no particular harm, and it is not necessary that they be completely removed.

(e) *Grind Clearance Angles.* The valve seats should now be narrowed down to the correct width. This is $\frac{1}{8}$ to $\frac{9}{64}$ inch. This operation is done principally by grinding the top of the valve seat with a 20-degree wheel ("B", fig. 81). A 70-degree wheel will be used to clean up the inside diameter of the valve seat, if necessary. When narrowing the valve seat, make sure the seat contacts in the center of the valve face. This is very important because the life of a valve grind job depends largely upon the width and location of the valve seat contact. If the valve seat is too narrow, heat will not be dissipated from the valve head fast enough. If the seat is too wide, carbon particles may lodge between the valve and seat, causing the valve to hold open and burn both the valve and the seat. After grinding the 45-degree angle, blue the seat and insert a valve to check the contact area. Then proceed with the 20- and 70-degree wheels to narrow the width as required.

(f) *Lapping Valves.* Seats reconditioned by grinding should not require lapping. There is danger, if valves are lapped in position, of some of the compound used getting on the valve stems and in the cylinder heads. This material is difficult to completely remove, and even small traces can be extremely detrimental to satisfactory operation of the cylinder. For that reason, it is recommended that valves will not be lapped after a reconditioning job.

(7) **RECONDITION CYLINDER BORE.** Cylinder barrels are ground with a tapered, or choked bore at the head end so that at operating temperatures both barrel and head expand a sufficient amount to provide a straight bore. Do not hone or grind cylinder barrels. When installing new pistons or new piston rings in a used barrel,

R975-C1 ENGINE (CONTINENTAL)

it is necessary to break the glazed surface of the cylinder with crocus cloth wetted in gasoline. This will aid in shortening the break-in required of piston rings.

(8) **SPARK PLUG INSERTS.** Do not attempt the replacement of spark plug inserts.

o. Repair Pistons. Do not perform repairs other than very light filing of the skirt diameter. The skirt may be filed lightly, using a fine mill file, but only to the extent that projecting metal at the sides of scratches is removed. Never attempt to completely remove scratches. After smoothing over the top, allow the scratch to remain; it will soon fill with carbon during engine operation. Use light pressure on the file and a rolling motion with the hand in order to avoid forming flat spots. Do not remove any metal below the normal contour of the piston skirt.

p. Repair Piston Pins. Slight scoring of the piston pins will be removed with crocus cloth and gasoline. Cracked, worn, or bent piston pins must be replaced.

q. Repair Articulated Connecting Rods.

(1) **TOOLS TO BE USED.** Tool-set 41-T-3539-8 is used to perform the operations described in this subparagraph and in subparagraphs r and s below. The components of the tool-set are identified and their use illustrated in figures 82 through 85.

(2) **REPLACE PISTON PIN BUSHINGS.**

(a) **Remove Bushing.** To remove the piston pin bushing from the connecting rod, insert the small end of the plug in the piston pin bushing. Place the base on an arbor press table, and insert the collar in the base. Support the rod over the collar so that the plug extends through the piston pin bushings and into the collar ("A", fig. 82). Press out the old bushing. Remove the plug and the rod. Clean up the rod bore and remove all burrs.

(b) **Install New Bushing.** To install new piston pin bushings, place the bushing on the small end of the plug, and screw the cap on the plug. Lubricate the outside diameter of the new bushing with castor oil. Place the piston pin end of the rod over the collar, and insert the large end of the plug through the bore so that it extends into the collar. Locate the split in the piston pin bushing in the extreme end of the rod at an angle of 45 degrees to the center line of the rod channel (fig. 83). Using an arbor press, push down on the cap on top of the plug until the press in plug bottoms against the collar ("B", fig. 82). Remove the plug and collar. The bushing should project 0.100 inch on each side of the rod after the ends have been cleaned up and polished.

ORDNANCE MAINTENANCE — 9-CYLINDER, RADIAL, GASOLINE ENGINE
(CONTINENTAL MODEL R975-C1)

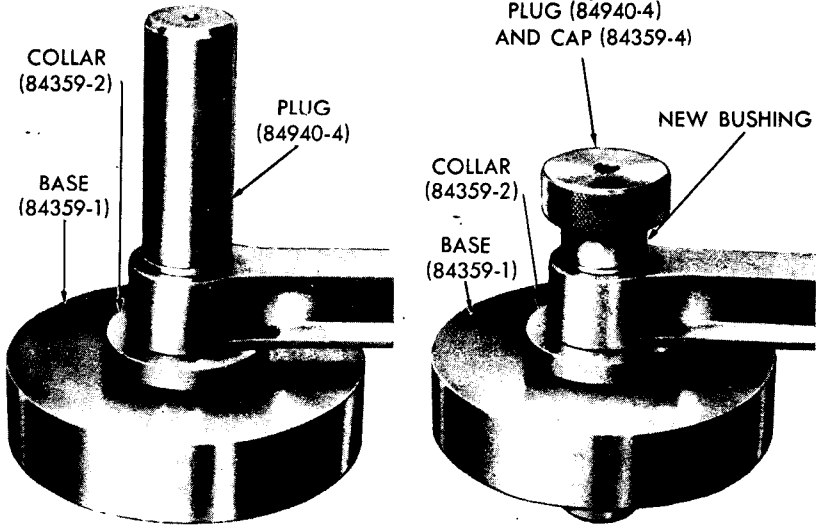

A—REMOVING BUSHING

B—INSTALLING NEW BUSHING

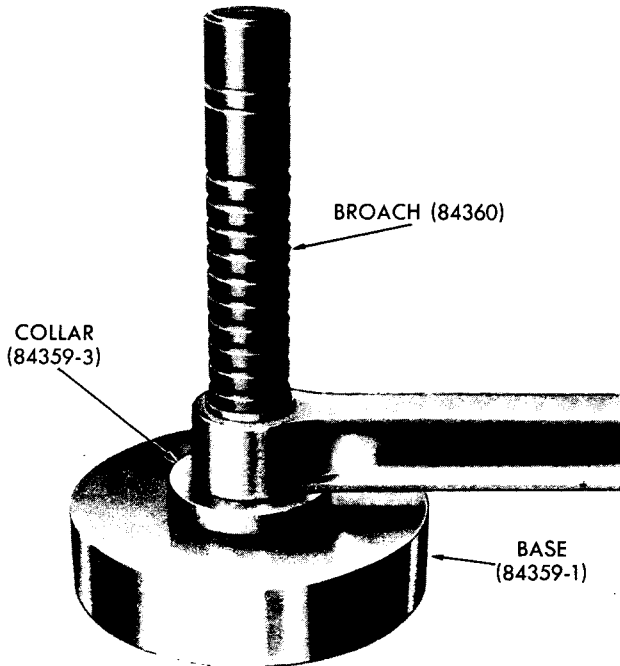

C—BURNISHING BUSHING

RA PD 309902

Figure 82 — Replacing Piston Pin Bushing in Articulated Rod

R975-C1 ENGINE (CONTINENTAL)

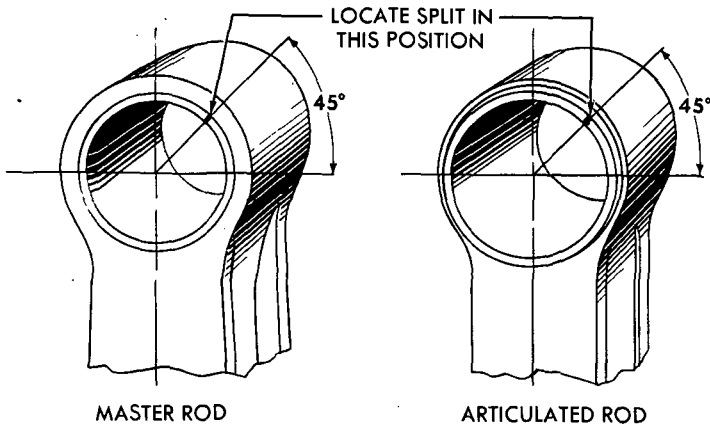

RA. PD 309885

Figure 83 — Connecting Rods, Showing Location of Split in Bushing

(c) *Broach Bushing.* After a new bushing has been installed, it should be broached to provide a full surface contact between the bushing and the bushing bore in the rod. This is accomplished by pressing a burnishing broach through the bushing by means of an arbor press ("C", fig. 82). Place the collar in the base, and set the base with the collar on an arbor press table. Locate the rod with the new piston pin bushing over the collar in the base, and burnish broach the bushing.

(d) *Bore Bushing.* Diamond bore the bushing to an inside diameter of 1.2495 to 1.2505 inches. Break sharp edges at each end of the bushing.

(3) REPLACE KNUCKLE PIN BUSHINGS.

(a) *Remove Bushing.* Remove, install, and broach knuckle pin bushings in the same manner as described in the preceding subparagraph for the piston pin bushings (fig. 84). Locate the split in the knuckle pin bushing in the extreme end of the rod and at a 45-degree angle as shown for the piston pin bushing in figure 83.

(b) *Face Bushing.* Face off both ends of the bushing to a complete over-all length within the gage dimension of 1.378 to 1.382 inches ("D", fig. 84). The bushing must project an equal amount on each side of the rod.

(c) *Bore Bushing.* Diamond bore the bushing to 0.8765 to 0.8772 inch inside diameter. Break sharp edges at each end of the bushing.

r. *Repair Knuckle Pins.* Clean out oil passages thoroughly. Polish with crocus cloth to remove scratches and galling caused by assembly or disassembly of the pins.

ORDNANCE MAINTENANCE — 9-CYLINDER, RADIAL, GASOLINE ENGINE
(CONTINENTAL MODEL R975-C1)

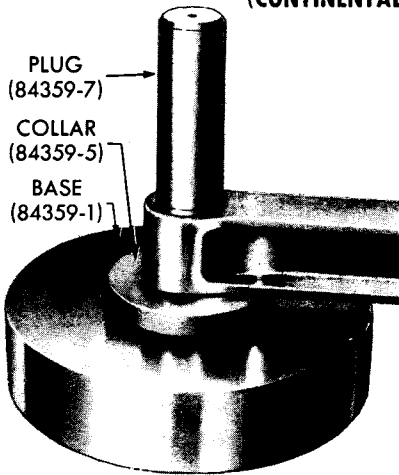

A — REMOVING BUSHING

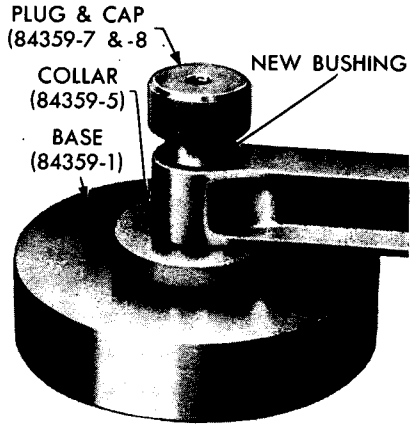

B — INSTALLING NEW BUSHING

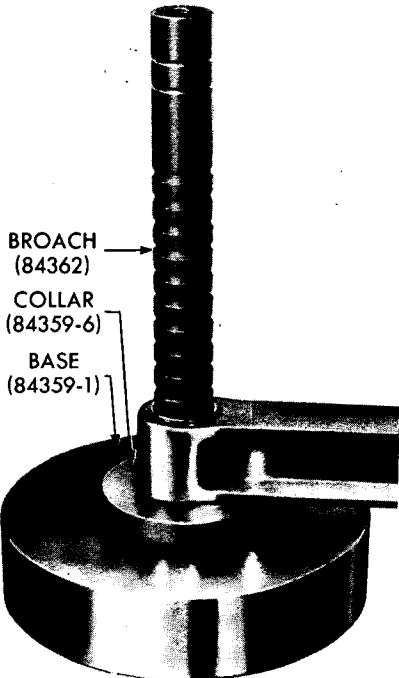

C — BURNISHING BUSHING

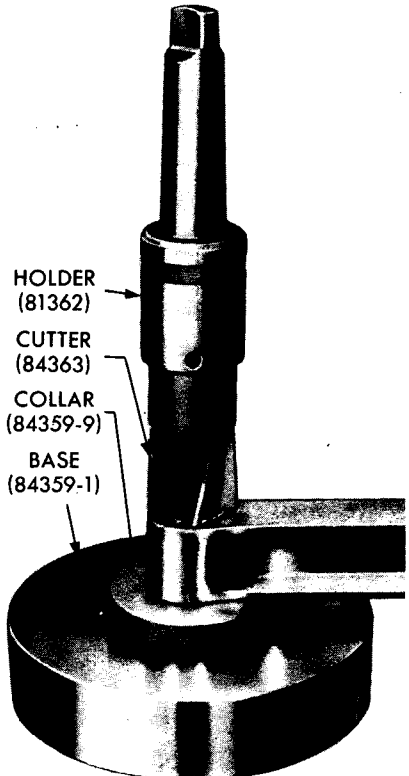

D — FACING BUSHING END

RA PD 309900

Figure 84 — Replacing Knuckle Pin Bushing in Articulated Rod

R975-C1 ENGINE (CONTINENTAL)

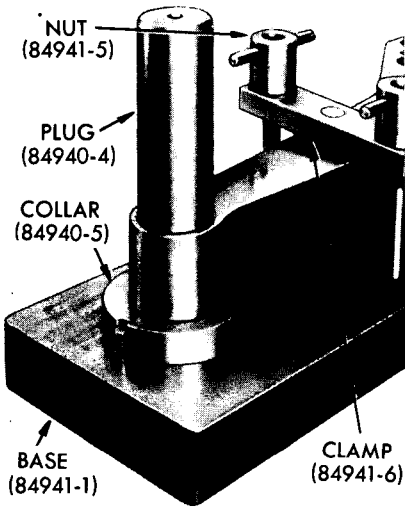

A—REMOVING BUSHING

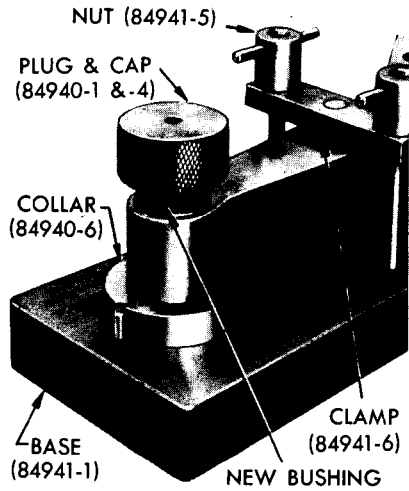

B—INSTALLING NEW BUSHING

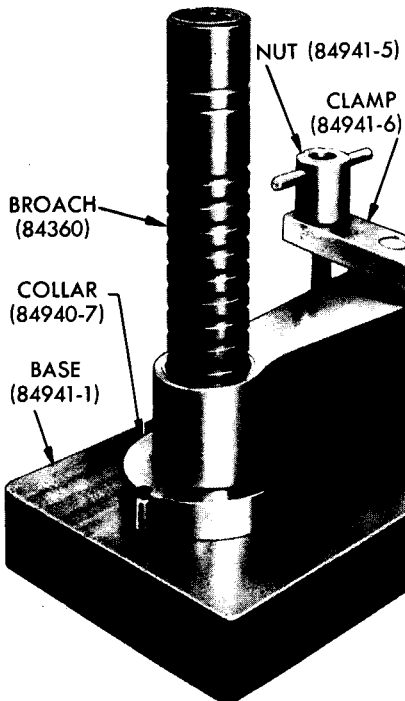

C—BURNISHING BUSHING

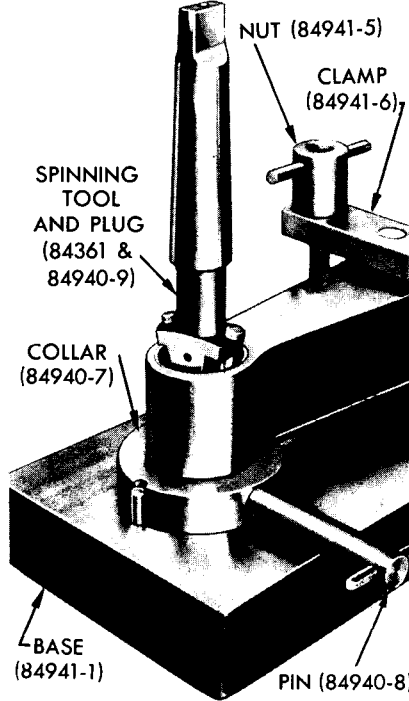

D—SPINNING OVER ENDS OF BUSHING

RA PD 309901

Figure 85 — Replacing Piston Pin Bushing in Master Rod

**ORDNANCE MAINTENANCE — 9-CYLINDER, RADIAL, GASOLINE ENGINE
(CONTINENTAL MODEL R975-C1)****a. Repair Master Connecting Rod and Bearing.****(1) REPLACE PISTON PIN BUSHING.**

(a) *Remove Bushing.* Replacement of the piston pin bushing in the master rod will be handled in accordance with the instructions outlined under repair of articulated connecting rods. The bushing will be removed and installed in the same manner except that different parts of the tool set will be used, and it will be necessary to spin over the ends of the bushing (fig. 85). See figure 83 for location of the split in the bushing, before installing a new bushing.

(b) *Spin Bushing Ends.* After installation and burnishing of the bushing, support the piston pin end of the rod on the plug and base, and spin over the end of the bushing, using the spinning tool inserted in a drill press spindle ("D", fig. 85). Invert the rod, and spin over the other end of the bushing. The ends of the bushing are to be spun over until they bottom against the chamfer machined at each end of the bushing bore in the rod.

(c) *Bore Bushing.* Diamond bore to the same sizes specified for piston pin bushings in articulated connecting rods. Break sharp edges at each end of the bushings.

(2) REPLACE MASTER ROD BEARING.

(a) *Remove Bearing.* Drill out the locking pin, and bore the bearing until the wall thickness is approximately 0.015 inch thick. Use the boring fixture (41-F-2897-425) for this operation. Collapse the remaining shell and remove from the rod. Clean and polish the master rod bore, and check the diameter against the size of the new bearing to be installed. It is highly important that specifications (0.001 to 0.003-inch press fit) be closely adhered to when fitting this bearing.

(b) *Identify New Bearing.* Beginning with engine No. 306252, a change was made in machining of oil grooves in the master rod bearing. The internal oil groove (annulus) now lines up directly with the outlet from the hollow crankpin (fig. 86). Machined slots on the steel back of the bearing liner transfer oil collected by the internal oil grooves to an external groove that registers with drilled holes to the knuckle pins. In this manner the knuckle pins and articulated rod knuckle pin bushings receive full pressure lubrication at all times. New type master rod bearings are interchangeable with those previously installed and should always be used for replacements.

(c) *Install New Bearing.* To install a new bearing, heat the rod in an oil bath at a temperature of 450°F for at least 1 hour. Remove the rod from the hot oil, and insert the new bearing, using an arbor

R975-C1 ENGINE (CONTINENTAL)

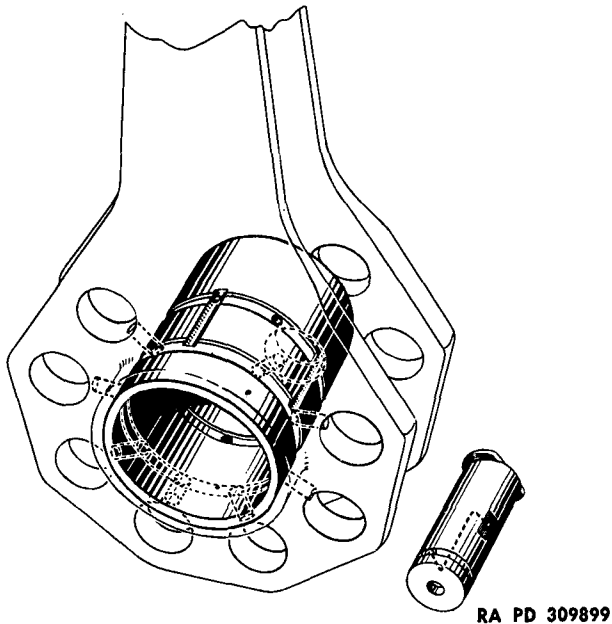
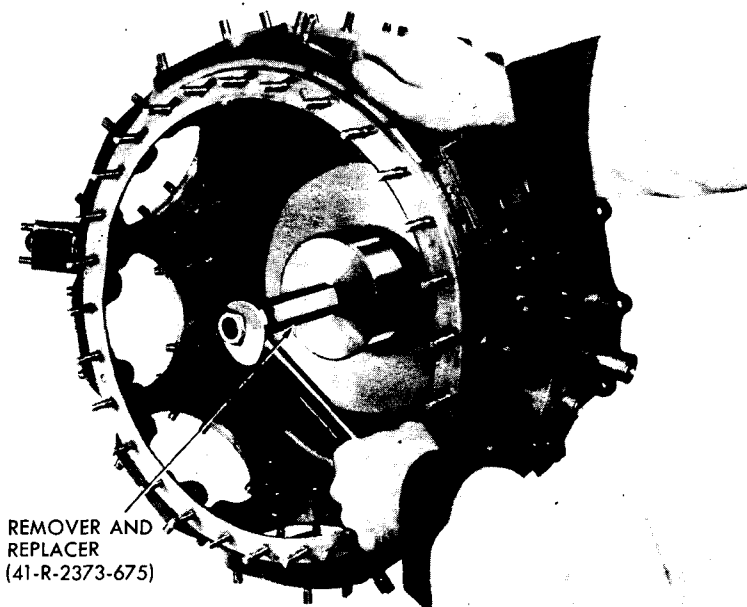

Figure 86 – Master Rod and Bearing

press and the plug and collar (41-P-2115-500). Note that small oilholes are drilled through the master rod to the knuckle pin holes in one flange only. When installing the bearing, make certain it is inserted so that the oil groove on the steel back will line up with the drilled holes in one flange of the master rod. This is important, because no supply of pressure lubricant will reach articulated rod bushings if the master rod bearing is assembled with the ends reversed.

(d) *Install Locking Pin.* Drill the locking pin hole in the bearing shell, and ream out the counterbore in the rod. Place the rod on a suitable mandrel, and tap the locking pin in place. Peen over the metal to secure the pin, using the staking punch (41-P-3762).

(e) *Bore Bearing.* Preparatory to boring the bearing, assemble the knuckle pins in the rod, except where fixture locating bars are used, to counteract any distorting effect on the bearing hole that the pressure exerted by the knuckle pins might cause. Seal the oilholes with heavy grease to prevent any metal entering the oil passages. Place the rod in a holding fixture, and bore out the bearing to allow proper clearance for the crankpin (0.0023 to 0.0035-inch clearance). Remove the rod, and break all sharp edges. Clean the rod thoroughly. Withdraw the knuckle pins, and remove grease from the oilholes. Clean the knuckle pins.

ORDNANCE MAINTENANCE — 9-CYLINDER, RADIAL, GASOLINE ENGINE
(CONTINENTAL MODEL R975-C1)REMOVER AND
REPLACER
(41-R-2373-675)

RA PD 336201

Figure 87 — Removing Rear Main Bearing

(3) **REMOVE SCRATCHES.** Connecting rods must be made and kept free of all dents and scratches, no matter how small they may appear. These parts are subjected to extremely high centrifugal forces, and heavy loads are imposed on them during the power strokes. Loads continually change and reverse direction, and fatigue cracks can easily develop if they are given a starting point. Small scratches, nicks, or dents furnish these starting points, so it is extremely important that they be located and removed. To remove damage of this kind, use the finest grained stone available and keep it wet with unleaded gasoline. Polish over any stoned areas with crocus cloth and gasoline, or with a very soft stitched cloth polishing wheel.

t. Repair Crankcase Main Section.**(1) REPLACE CRANKSHAFT REAR BEARING.**

(a) *Remove Bearing.* To replace the crankshaft rear bearing, heat the crankcase in a flameless oven to 285° F and remove the bearing with the remover (41-R-2373-675) (fig. 87). Allow the crankcase to cool to room temperature. Clean and polish the bore in the crankcase, and check diameter for comparison with size of the new bearing to see that specified press fit of 0.002 to 0.004 inch will be provided.

R975-C1 ENGINE (CONTINENTAL)

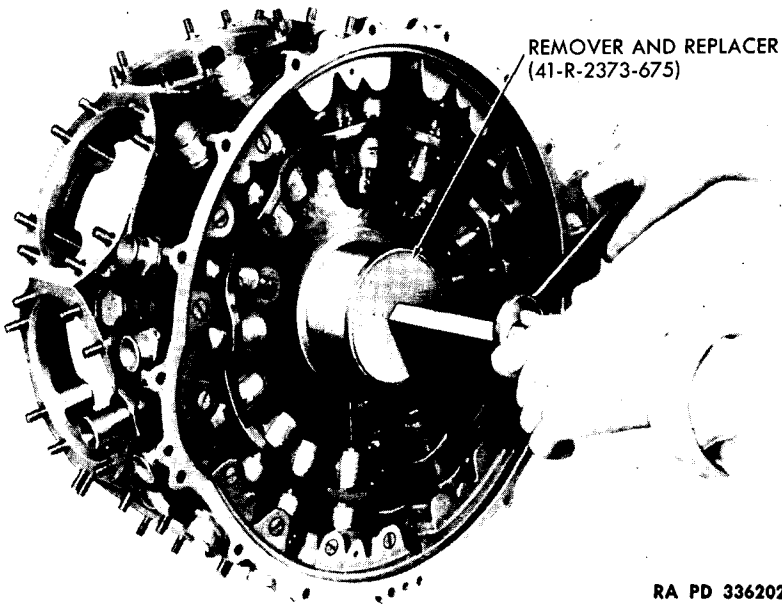

RA PD 336202

Figure 88 — Installing Rear Main Bearing

(b) *Install New Bearing.* Place the crankcase in the oven and reheat to 285°F. Install the key in its slot in the bearing shell with the rounded corners out. The key should be a light drive fit in its slot. Remove the crankcase from the oven, and install the bearing in place, using replacer (41-R-2373-675) (fig. 88). Make sure the flange is shouldered on the front face. Be sure the threads on the outer diameter of the shell are not damaged.

(c) *Ream Bearing.* Plug the oil holes in the bearing with heavy grease. Assemble the crankcase main section hand reaming fixture (41-F-2994-21), and partly ream out the bearing with a semifinish reamer (fig 89). Use the finish reamer to ream the bearing to size (0.002 to 0.004-inch clearance on crankshaft). Break all sharp edges. Remove the crankcase from the holding fixture. Clean the grease from the oilholes, and blow out the oil passages with compressed air.

(2) REPLACE VALVE TAPPET GUIDE.

(a) *Remove Guide.* Back out the push rod housing adapter using the socket wrench (41-W-2964-550) and extension (41-E-515), (fig. 90). Heat the crankcase in a flameless oven to approximately 285°F, and remove the guide. Allow the case to cool, and clean out any galling or roughness on the piloting diameters in the crankcase with crocus cloth. Measure inside diameters, and compare with

ORDNANCE MAINTENANCE — 9-CYLINDER, RADIAL, GASOLINE ENGINE
(CONTINENTAL MODEL R975-C1)

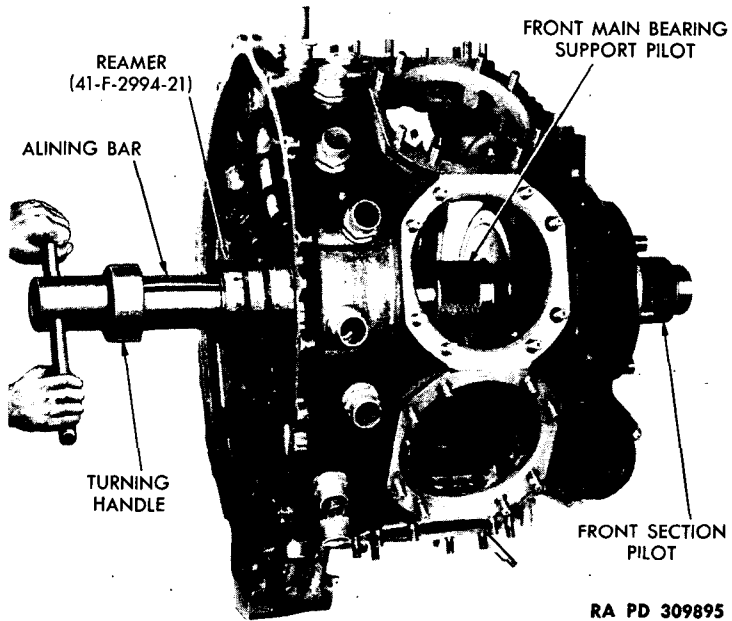

Figure 89 — Reaming Crankshaft Rear Main Bearing

a new tappet guide to determine that the proper amount of press fit (0.001 to 0.003 inch) will be provided. Oversize tappet guides are available should it be necessary to ream the hole oversize to clean up.

(b) *Install New Guide.* Tappet guides for cylinders located above the horizontal center line are drilled to provide positive lubrication of the rocker arms and valves. Other tappet guides are not drilled. Closely examine the guide removed, to determine which type it is so that a similar type guide will be installed. Heat the case in a flameless oven to 285° F, and cool the guide in dry ice. Place the guide on the installing and alining bar (41-B-332), and insert in the crankcase. Make sure the flange of the guide is bottomed before the case cools. Using a new rubber seal, install the push rod housing adapter, and tighten with the socket wrench (41-W-2964-550) and extension (41-E-515) to 700 to 750 inch-pound torque.

(c) *Hone Guide.* After installation in the crankcase and assembly of the oil seal and adapter, the valve tappet guide will be honed to size. Use a standard expansion tool together with an electric drill, and hone the guide to an inside diameter of 0.6876 to 0.6883 inch. Notice that extremely close tolerances are specified in this location,

R975-C1 ENGINE (CONTINENTAL)

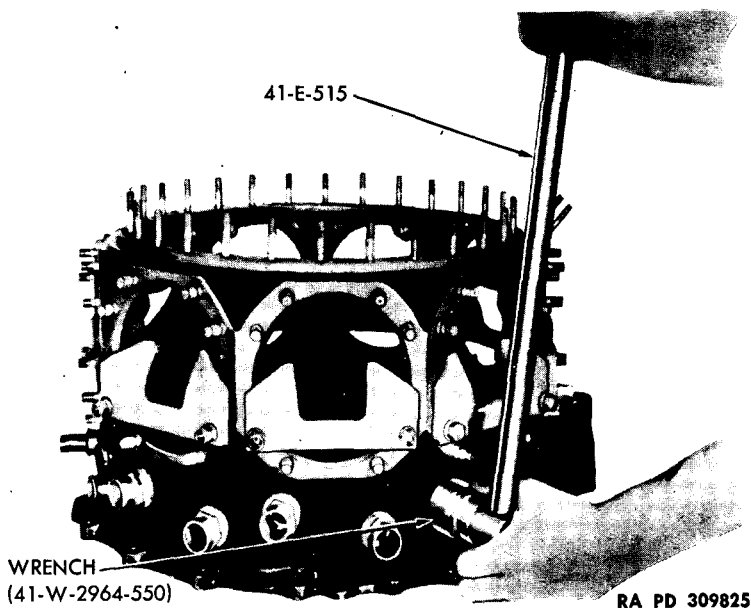

Figure 90 — Removing Valve Tappet Retainer Nut

so it will be necessary to exercise care that the guide is not honed oversize. Clean oil passages after honing.

(3) **REPAIR VALVE TAPPETS.** Remove any slight burrs or nicks that may have been incurred by rough handling. Worn, scored, or overheated valve tappet parts should be replaced.

(4) **GENERAL REPAIR.** No satisfactory method of repairing cracks in structural members of the engine has been found. If cracks are located in the crankcase main section, it must be discarded and replaced with a new assembly. Stone to smooth over any nicks, burrs, or rough edges on the machined surfaces. This is important, as alinement of the various subassemblies and oil sealing at the mating faces is thereby affected. Use care to determine that no low spots are being formed by the stoning. If a new crankshaft rear bearing is to be installed, all stud replacements should be completed before commencing the bearing job. Refer to the instructions contained in paragraph 10 g for replacement of studs.

u. Repair Front Crankshaft. Light and very fine scuff marks on the crankpin journal may be polished with a long strip of crocus cloth wetted in gasoline. Grooving of the crankpin can be corrected only by replacement with a new crankshaft. Do not attempt to stone or grind the crankpin undersize. Using a fine stone, clean up galling.

**ORDNANCE MAINTENANCE — 9-CYLINDER, RADIAL, GASOLINE ENGINE
(CONTINENTAL MODEL R975-C1)**

and remove nicks or burs wherever they may be found on the crankshaft. It is especially important that all nicks and scratches be located and removed.

v. Repair Rear Crankshaft.

(1) **POLISH BEARING JOURNAL.** The rear bearing journal will be polished with a long strip of crocus cloth, if necessary, to remove light scuffing. Grooving or nicks are not to be corrected by regrinding. If the shaft is grooved, nicked, or shows evidence of overheating on the bearing journal, it should be replaced. Remove all small nicks and burs from the crankcheek.

(2) **REPLACE DAMPER PIN BUSHINGS.** Dynamic damper pin bushings in the rear crankcheek or in the damper weight itself may be removed by pressing out with a suitable shouldered arbor. Clean up any roughness caused by removal of the old bushing. Cool a new bushing in dry ice, and coat the bushing hole in the crankcheek or damper weight with graphite grease. Remove the bushing from the dry ice, and install it in place so that the ends of the bushing are not projecting above either face of the crankcheek.

w. Repair Rear Crankshaft Gear. Remove any slight scores or nicks with a fine stone, and polish with crocus cloth.

x. Repair Cam and Cam Drive Gear.**(1) REPLACE CAM HUB BEARING.**

(a) *Remove Bearing.* Mount the cam assembly, gear side facing out, on the face plate of a lathe, and clamp firmly, but not tight. Make centering adjustments from the pitch line of the gear teeth by using a 0.184-inch diameter round pin placed between any two teeth. Tighten clamps, and bore out the old bearing until only a thin shell (approximately 0.015 inch thick) remains. This shell will then be broken out and the remaining pieces of the three retaining rivets driven out of the hub. Smooth the inside diameter of the hub and the pin holes with crocus cloth if they are rough.

(b) *Check Size.* Check inside diameter of the hub and outside diameter of the new bearing to determine that a press fit of 0.0015 to 0.0045 inch will be provided when the parts are assembled.

(c) *Install New Bearing.* Submerge the cam assembly in oil heated to 285° F for 10 minutes. Place a light coating of engine oil on the steel back of the new bearing. Remove the cam assembly from the hot oil and mount it on the collar (41-C-2482-100) placed on an arbor press. Assemble the bearing to the plug (41-P-2098-500) and, with the bearing carefully centered over the hub, press it until the shoulder seats firmly against the hub. Check to see that the

R975-C1 ENGINE (CONTINENTAL)

shoulder is well seated all the way around before the cam cools or has had time to heat the new bearing appreciably.

(d) *Install Locking Pins.* Install the cam on the locating jig, and drill three lock pin holes, using a $1\frac{1}{64}$ -inch drill. Ream the holes to size with a 0.183-inch reamer, and insert the locking pins. Lightly peen the metal around the pin hole, using the fixture (41-F-2987-500) and the punch (41-P-3160).

(e) *Bore Bearing.* Set up the new assembly in a lathe, and center on the pitch line of the gear teeth as previously described. Diamond bore the bearing to a size that will provide clearance of 0.003 to 0.005 inch on the support. Break sharp edges after boring the bearing.

(2) **GENERAL CAM REPAIR.** Light scuffing of the tappet roller tracks on the cam will be smoothed over with a very fine stone and polished with crocus cloth. No attempt shall be made to remove small pits worn into the case hardened surface of the cam. Light scratching of the hub bearing will be smoothed with a burnishing tool provided the bearing has not worn beyond the clearance limit of 0.008 inch.

22. ASSEMBLY OF THE MAIN SECTION.

a. Assemble Cylinders.

(1) **INSTALL VALVES.** Check to see that valve guides and valve stems are clean before starting to assemble the cylinders. Oil the valve stems and insert them carefully in the guides. Be sure to get the valves in the right cylinders.

(2) **INSTALL CIRCLETS.** Place the small wire locking rings, or circlets, in the grooves provided near the tip ends of the valve stems, and set the cylinder on the assembly stand (41-S-4988-77).

(3) **ASSEMBLE VALVE SPRINGS.** Place the three lower spring washers (exhaust), the three valve springs, and the upper washer over the protruding end of the valve guide. On the intake side, two lower washers are used under the springs instead of three. Install the valve spring compressor (41-C-2559-25) and compress the springs. Install the valve locks, and make certain they are properly located in the valve stem groove before releasing the compressor. Remove the compressor, and tap the valve stem end lightly to seat the split locks. Temporarily, install the rocker arm and check for interference between the underside of the arm or roller and the upper valve spring washer.

(4) **UNDERSIZED WASHERS.** A valve spring washer with an undersize bore is available for use when the valve face and seat have been ground to such an extent that interference occurs between the rocker arm and the standard washer. The undersize bore washer will seat

ORDNANCE MAINTENANCE — 9-CYLINDER, RADIAL, GASOLINE ENGINE
(CONTINENTAL MODEL R975-C1)

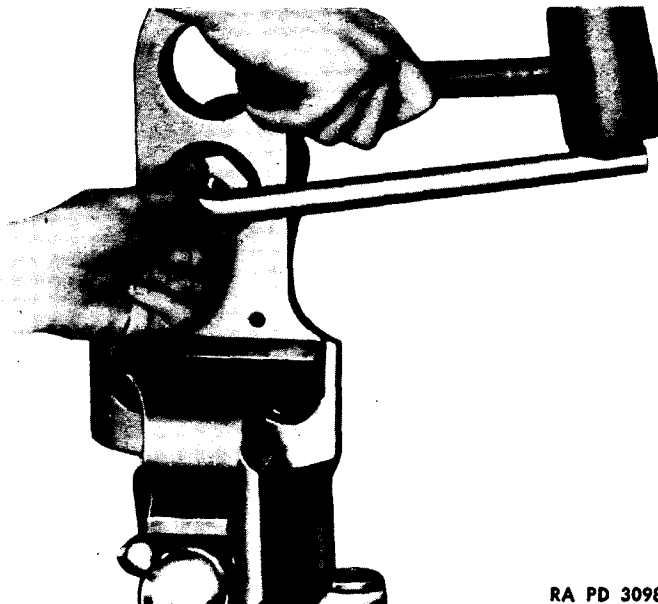

RA PD 309860

Figure 91 — Tightening Rear Crankshaft Front Plug

lower on the valve stem than the standard washer and must only be used when interference exists between the standard washer and the rocker arm or roller.

(5) **ASSEMBLE EXHAUST ELBOWS.** Use a new gasket, and install the exhaust elbows. Secure with flat washers, castellated nuts, and lock wire. Use the special wrench (41-W-1471), and tighten the nuts to 225 to 250 inch-pounds.

(6) **MISCELLANEOUS PARTS.** Other parts will not be installed until after the cylinders have been attached to the crankcase main section.

b. Assemble Crankshaft Gear, Crankshaft, and Master Connecting Rod.

(1) **ASSEMBLE GEAR.** Insert the crankshaft gear hub in the gear and turn it so the gear lugs are between the slots in the hub. Insert the pins in the end of each spring, and push the spring and pin assembly into position. Place the retainer in position on the gear assembly, aligning the cut-outs with the screw holes in the hub.

(2) **ASSEMBLE FRONT PLUG.** Slide the crankpin bore plug in place in the front crankshaft, and secure it with the retaining cap screw and a new locking plate. Do not coat the plug with white

R975-C1 ENGINE (CONTINENTAL)



RA PD 309862

Figure 92 – Installing Dynamic Damper Pin

lead or sealing compounds of any kind. Bend one prong of the lock plate over the edge of the crankcheek and the other up against a flat on the retaining cap screw head.

(3) **ASSEMBLE FRONT BEARING SPACER.** Support the front crankshaft by clamping the crankcheek between aluminum jaws in a vise. Assemble the crankshaft front bearing spacer, chamfered side toward the crankcheek, on the crankshaft. Heat the front bearing in a bath of engine oil to 180° to 200° F and assemble on the shaft with the roller retainer facing toward the front. Coat the front bearing retainer nut threads with thread lubricant and install on the shaft. Tighten the nut with the spanner wrench (41-W-871-27), using special care to avoid marking the shaft (fig. 67). Aline cotter pin holes of the lock nut at tight position with the hole in the shaft, and install a new cotter pin from the outside. If the holes do not aline, it will be necessary to drill a new hole through the shaft.

(4) **ASSEMBLE REAR PLUG.** Insert the rear crankshaft rear bearing journal bore plug in the bore and tap into place with a fiber drift. This plug is retained by the crankshaft gear.

(5) **ASSEMBLE REAR CRANKSHAFT FRONT PLUG.** Install and tighten the rear crankshaft front plug if it has been removed. If the plug has not been removed, check to see that it is tight (fig. 91).

**ORDNANCE MAINTENANCE — 9-CYLINDER, RADIAL, GASOLINE ENGINE
(CONTINENTAL MODEL R975-C1)**

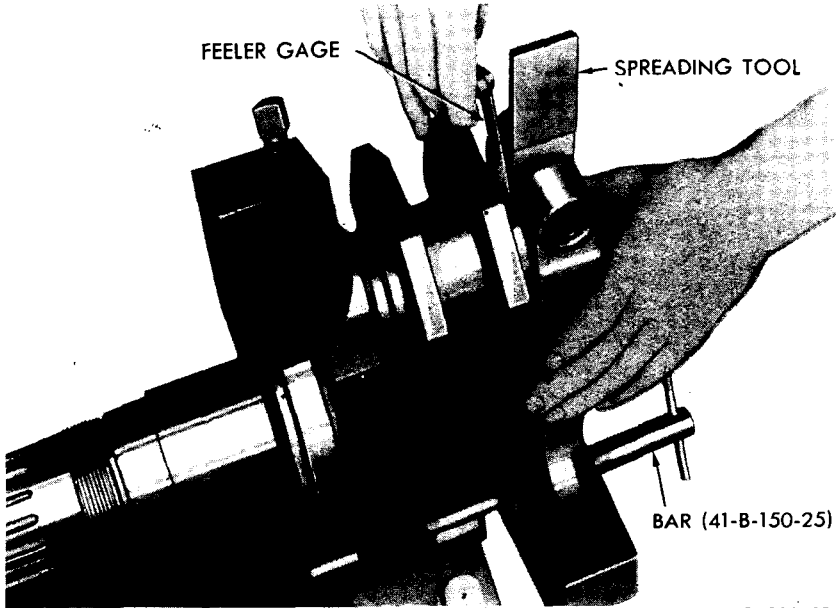

RA PD 309863

**Figure 93 — Measuring End Clearance Between Master Rod
and Rear Crankshaft**

(6) **ASSEMBLE DYNAMIC DAMPER.** Slide the crankcheek extension through the slot in the dynamic damper weight and align the pin holes. Insert the two pins and attach the stop plate (fig. 92). Line up one flat on the bolt head against the stop when inserting the bolts. Secure bolts with castellated nuts and cotter pins.

(7) **ASSEMBLE ROD BEARING SPACER.** Place the front crankshaft in the stand (41-S-4932) and again carefully examine the crankpin for nicks or burs. Heat the master rod bearing spacer in oil to 300° F and slip on the crankpin, making sure the rounded side is against the crankpin fillet. Coat the crankpin with a liberal supply of engine oil.

(8) **ASSEMBLE MASTER ROD.** Install the master rod on the crankpin, with the knuckle pin locking screw holes toward the front. Spread the rear crankcheek with the wedge tool, and slide onto the crankpin until the master rod bearing has the proper end clearance (0.017 to 0.019 inch) (fig. 93). Select the crankshaft alining bar (41-B-150-25, -27, or -30) which will give the best fit, and insert through the holes in the counterweight. Remove the spreading tool from the crankcheek. Coat threads on the crankcheek with thread lubricant. **CAUTION:** Do not put lubricant on cap screw threads. Assemble

R975-C1 ENGINE (CONTINENTAL)



RA PD 309844

Figure 94 – Measuring Crankcheek Cap Screw Stretch

the washer, chamfered side against the cap screw head, and install the two in the crankcheek, but do not tighten at this time. Place the measuring tool (41-T-3268) on the cap screw, and measure over the ends with a micrometer (fig. 94). Slide the alining bar out of the front counterweight, and remove the measuring tool from the cap screw. Tighten the cap screw with a $1\frac{3}{8}$ -inch heavy box end wrench and an extension handle (fig. 95). Tighten until the length of the cap screw has been increased by 0.005 to 0.007 inch. Stretch is determined by the difference in length measured before and after tightening. Check alinement between the crankshaft front and rear sections upon completion of tightening, to determine that they have not moved. Do not leave the alining bar through both counterweights while the cap screw is being tightened, since any movement of the rear section will cause the bar to bend. If the two sections are in line, lock the cap screw with a cotter pin inserted from the inside.

(9) **INSTALL COTTER PIN.** If the original cotter pin hole does not line up with the cap screw at any point in tightening the cap screw to stretch between 0.005 and 0.007 inch, it will be necessary to drill a new hole. The new hole must be removed from all other adjacent holes by at least $\frac{1}{4}$ inch, the distance being measured between the edges of the holes along the root diameter of the threads. If

ORDNANCE MAINTENANCE — 9-CYLINDER, RADIAL, GASOLINE ENGINE
(CONTINENTAL MODEL R975-C1)

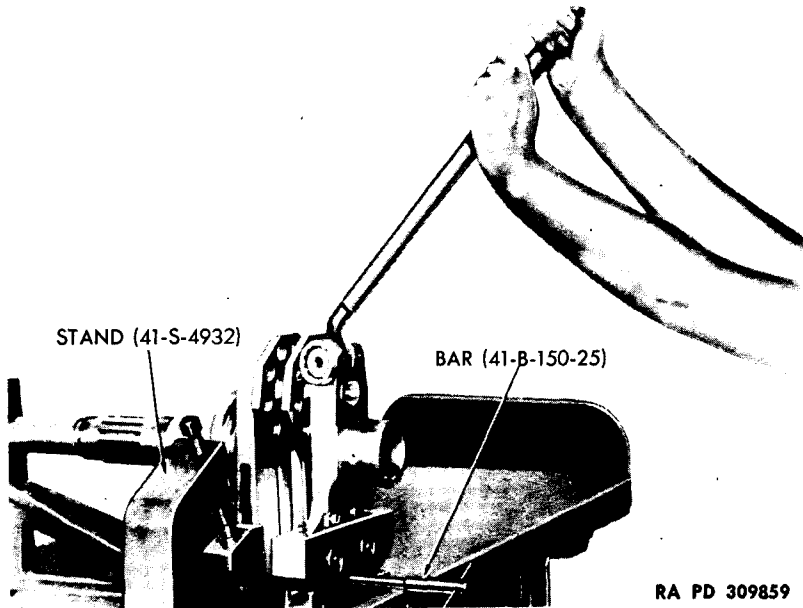

RA PD 309859

Figure 95 — Tightening Rear Crankcheek Cap Screw

the stretch limits make this impossible, it is permissible to reduce the thickness of the cap screw washer by as much as 0.010 inch by grinding from one or both sides of the washer. Care must be taken in grinding, as it is essential that all points of the washer bear evenly on the cap screw head. After grinding, break all sharp edges and check for interference on the fillet under the cap screw head.

(10) **CHECK CRANKSHAFT ALINEMENT.** Remove the crankshaft and master rod assembly from the holding fixture, and place on the adjustable rollers (41-R-2660) to check for alinement. One set of rollers should be located at the rear bearing journal and the other at the crankshaft front bearing location. The shaft and bench must be level. Locate a dial indicator so that it will register against the thrust bearing location. Rotate the shaft, and note the amount of run-out at this point. Recheck the amount of run-out at the point between the threads and the splines near the front of the shaft. The crankshaft may be out of alinement if the front and rear crankcheeks are not in perfect alinement. Any run-out greater than 0.004 inch full indicator reading will necessitate replacement of the shaft. Do not attempt to straighten a bent shaft.

R975-C1 ENGINE (CONTINENTAL)

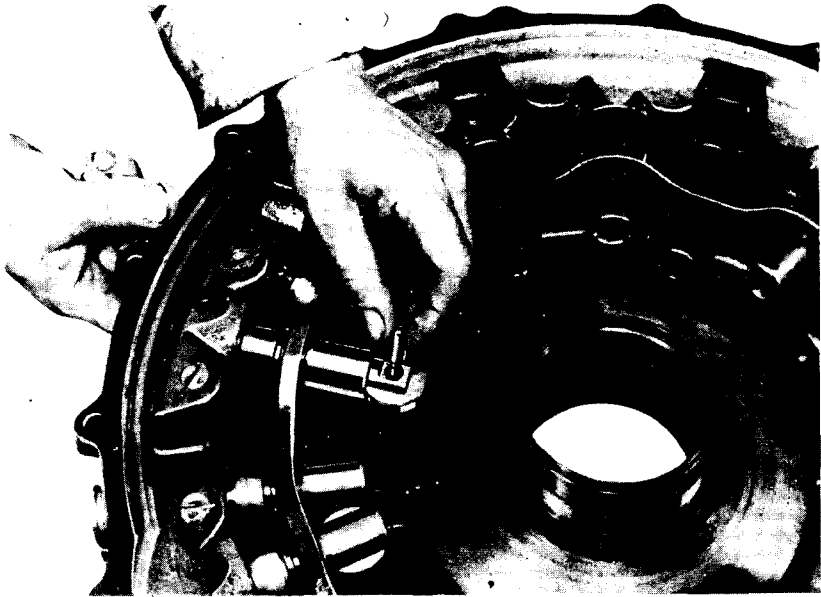

RA PD 309841

Figure 96 — Installing Tappet Roller Pins and Rollers

c. Assemble Valve Tappets and Cam.

(1) **INSTALL TAPPETS.** Use new oil seals, and reinstall the push rod housing adapters if they have been removed. To tighten the adapters, use the socket (41-W-2964-550) together with the extension (41-E-515). Try fit of each of the tappets in the guides before lubricating the parts. Tappets must slide through the guides with no interference or binding. Lubricate the valve tappets with engine oil, and insert in their respective guides. Slide toward the center of the main section until the tappet roller pin support holes are exposed (fig. 96). Place the rollers and pins in position, and slide the tappets outward until the pins are housed within the guides.

(2) **ASSEMBLE CAM.** Install the cam hub bearing spacer over the rear crankshaft bearing extension. Lubricate the cam hub bearing with engine oil, and place the cam in position (fig. 97). Apply thread lubricant to threads in the cam hub bearing support. Insert the support, and tighten with the lug wrench. Check end clearance of the cam hub bearing on the support (0.009 to 0.016 inch). Check alinement of the cam periphery with the tappet rollers. If the rollers extend over the rear edge of the cam periphery in any position, the spacer must be replaced. It may be necessary to grind the new spacer to the

**ORDNANCE MAINTENANCE — 9-CYLINDER, RADIAL, GASOLINE ENGINE
(CONTINENTAL MODEL R975-C1)**

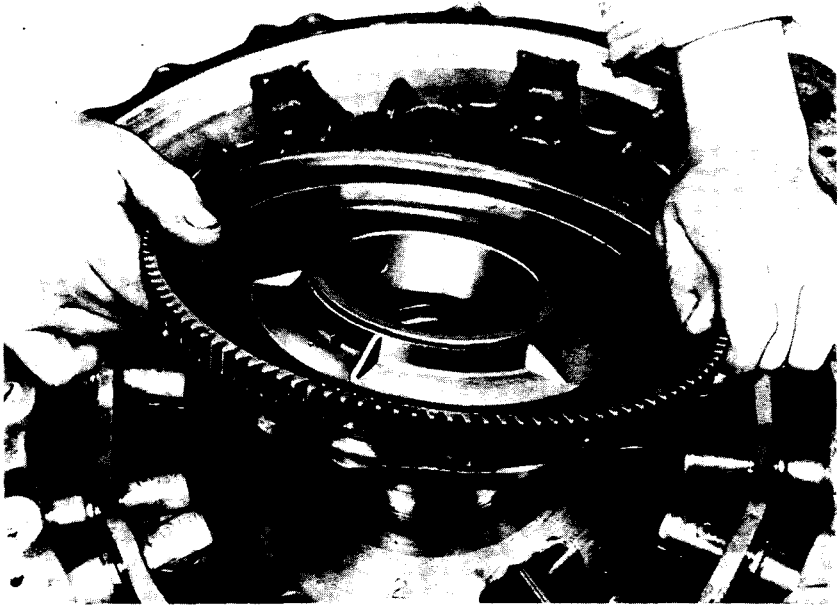

RA PD 309842

Figure 97 — Installing Cam and Bearing Assembly

desired thickness. If it is necessary to grind the spacer, it is essential that the surfaces be kept square with the inside diameter and the barrel within 0.002 inch. When the final assembly of the cam has been completed, lock the cam hub bearing support to the rear crankshaft bearing extension with two cotter pins, exercising care to select pins that will fit snugly in the holes. If the original cotter pin hole does not line up, it will be necessary to drill a new hole. The new hole must be drilled away from other adjacent holes by at least $\frac{1}{4}$ inch. At this time, a check should be made to determine that the name plate on the crankcase front section corresponds with the type of cam used in the engine. One type of cam is identified by the use of bolts in the hub. The name plate on an engine using the bolted cam must read "I. C. (Intake Valve Closes) 35° A. B. C." and "E. O. (Exhaust Valve Opens) 62° B. B. C." The other (later) type of cam is identified by the use of rivets in the hub. The name plate on an engine using the riveted cam must read "I. C. $34 \pm 4^{\circ}$ A. B. C." and "E. O. $56 \pm 4^{\circ}$ B. B. C." If the name plate and the cam used do not correspond, alter the name plate to make correction.

R975-C1 ENGINE (CONTINENTAL)

d. Assemble Crankcase Main Section and Crankshaft.

(1) **START ASSEMBLY.** Place the crankcase main section on a bench with the forward end up.

(2) **INSTALL CRANKSHAFT.** Lubricate the rear bearing journal on the assembled crankshaft and the crankshaft rear bearing in the crankcase main section with a liberal quantity of engine oil. Lower the crankshaft assembly into the crankcase, inclining the shaft at such an angle that the master rod can be thrust out No. 1 cylinder opening without the shaft striking the crankcase at any point. The counterweights are kept approximately 90 degrees to the master rod during this operation. Straighten the crankshaft assembly, and carefully lower it into the rear bearing. Place protector plate on No. 1 cylinder mounting pad, and secure with two cylinder hold-down nuts.

(3) **ASSEMBLE CRANKSHAFT GEAR.** Turn the crankcase on its side, and install the rear crankshaft gear on the rear of the crankshaft. Install the cap screws, tighten in place, and secure with lock wire.

e. Assemble Knuckle Pins and Articulated Connecting Rods.

(1) **IDENTIFY PARTS.** Clean the connecting rods and knuckle pins, and lubricate the pins and their holes in the master rod before assembling the connecting rod group. Knuckle pins, connecting rods, lock plates, and master rod flange all bear numbers which must index in assembly. This is of utmost importance, since it insures the alignment of oilholes and satisfactory fitting of the parts. The knuckle pin lock plates must be a tight fit between the pins.

(2) **ASSEMBLE ARTICULATED RODS.** Select two connecting rods which employ the same lock plate, hold them in place, and insert the two knuckle pins. Assemble the lock plate and the guides on the master rod, exercising care to see that the guides are bottomed in the lock plate screw holes. Aline the slots of the pins with the ends of the lock plates. Place the ram in position on the knuckle pins, and press the pins in with knuckle pin installing tool (fig. 98). Remove the tool and lock plate guides, and assemble the lock plate screws and screw locks in position. Tighten the screws, and bend one tab of the screw lock up against a flat on each screw head. Install the remaining articulated rods. As each rod is installed, place a protecting plate on the cylinder mounting pad, and secure with two cylinder hold-down nuts.

(3) **FIT LOCK PLATES.** Should it be necessary to install a new lock plate, select one from parts stock to provide a light tapping fit

**ORDNANCE MAINTENANCE — 9-CYLINDER, RADIAL, GASOLINE ENGINE
(CONTINENTAL MODEL R975-C1)**

Figure 98 — Installing Connecting Rod Knuckle Pins

when assembled between knuckle pins. The lock plate must be a tight fit between the knuckle pins.

f. Assemble Piston Rings on Piston.

(1) **IDENTIFY RINGS.** New piston rings are to be installed at each engine overhaul. Two important clearances must be maintained when fitting new piston rings; the gap between the ends of the rings when in place in the cylinders in which they will operate, and the side clearance between the rings and the ring grooves in the piston.

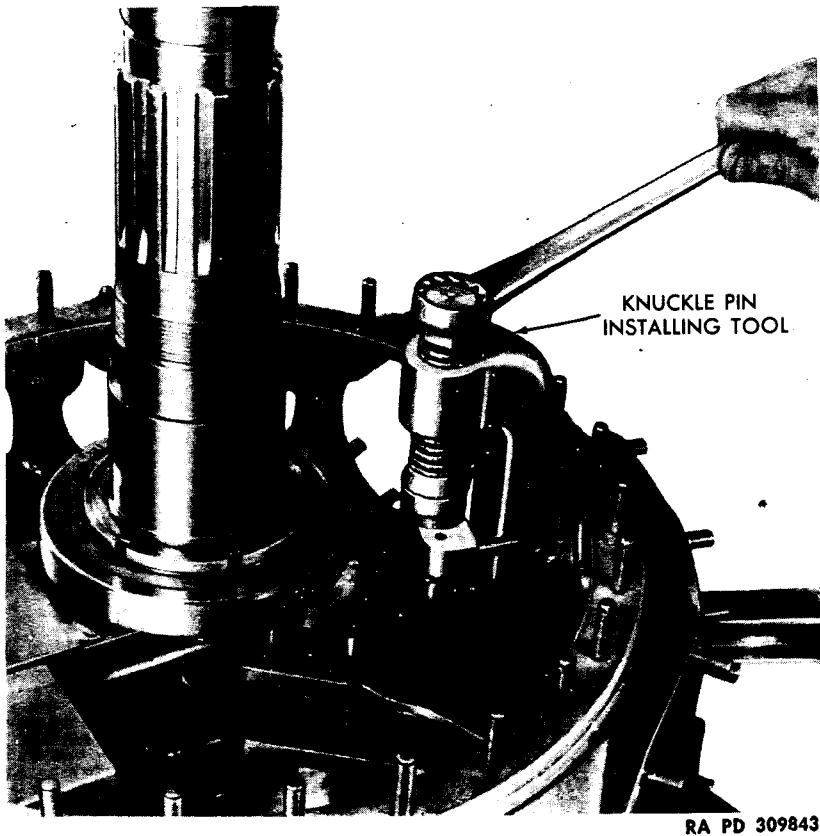
(2) **CHECK RING GAP.** To check the piston rings for gap, use a standard 5.000-inch diameter gage. Set the ring to be checked in the gage, and push in until it seats against the shoulder. With a set of thickness gages, measure the clearance between ends (0.025 to

R975-C1 ENGINE (CONTINENTAL)

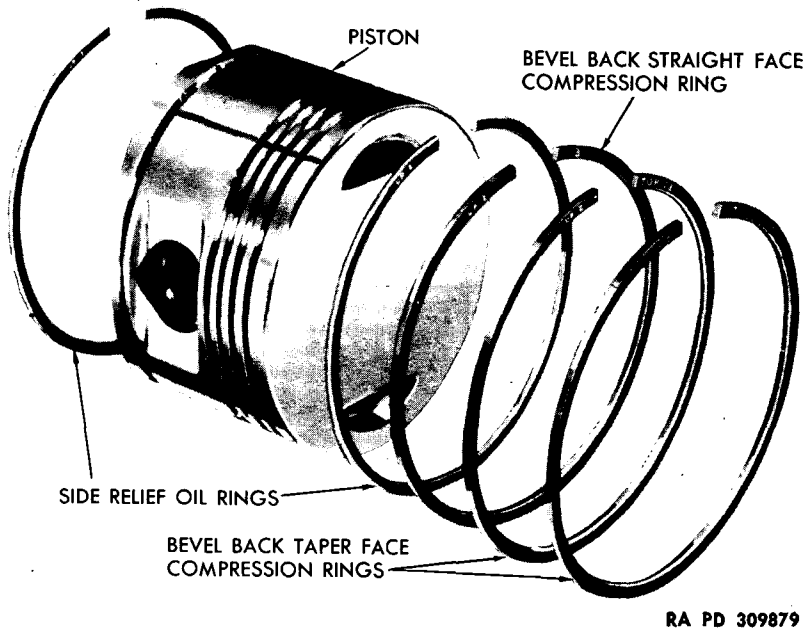

RA PD 309879

Figure 99 – Sequence of Piston Ring Assembly

0.031 inch). Only standard size piston rings are to be used since the cylinder bore is tapered and no provision made for grinding oversize.

(3) **ASSEMBLE RINGS.** Assemble all rings on the pistons, and check the amount of side clearance. Use a standard 5-inch piston ring expander to install piston rings on the pistons. All of the rings are marked with the word "UP" on the top side. Rings for the top two grooves are the same, and are identified by "1 & 2" stamped on the top side (fig. 99). The third groove ring is stamped "3". Fourth and fifth groove rings are the same, but are not identified with numbers. Check side clearance of the installed piston rings by inserting thickness gages between the top of the ring and the ring land (top ring 0.0055 to 0.007 inch, second 0.004 to 0.0055 inch, third, fourth, and fifth 0.0025 to 0.004 inch). Make certain that the grooves are clean before installing piston rings; otherwise, an accurate check of the clearance cannot be made.

g. Assemble Ignition Wiring Harness.

(1) **CUT WIRES.** New 7 millimeter ignition wire will be cut to the lengths specified in the following table and installed in the radio

**ORDNANCE MAINTENANCE — 9-CYLINDER, RADIAL, GASOLINE ENGINE
(CONTINENTAL MODEL R975-C1)**



























shielded conduits at each engine overhaul. *NOTE: Wire lengths shown in the table below are for assembly purposes only. Distributor block ends will be trimmed to the required lengths before copper ferrules are installed and magneto blocks attached.*

IGNITION MANIFOLD REWIRING CHART

Wiring Order	Rear Spark Plugs, Left Side Magneto		
	Cylinder No.	Magneto Block No.	Length
1	5R	3	64
2	4R	7	59
3	3R	2	51
4	2R	6	44
5	1R	1	36
6	6R	8	50
7	7R	4	44
8	8R	9	38
9	9R	5	32
	Front Spark Plugs, Right Side Magneto		
	Cylinder No.	Magneto Block No.	Length
10	5F	3	58
11	4F	7	58
12	3F	2	51
13	2F	6	43
14	1F	1	40
15	6F	8	72
16	7F	4	69
17	8F	9	55
18	9F	5	49

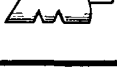
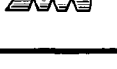
(2) **PLACE WIRES IN HOLDING FIXTURE.** A considerable amount of time will be saved, and rewiring of the harness greatly simplified if a wire-holding fixture similar to that shown in figure 100 is constructed. This simple holding fixture can be made from a piece of wood and stamped or lettered as shown. The first wire to be installed in the harness, according to the wiring order listed in the rewiring chart and on the fixture shown in figure 100, will be for the spark plug on the rear side of No. 5 cylinder, and 64 inches of new wire will be required. Cut a piece of wire to the required length, using the stripper and cutter (41-S-6010), and mark one end of it by cutting a single gash in the insulation approximately 1/4 inch from the end with a pair of wire cutters. The purpose of this identification mark is to provide a means of distinguishing between wires at the magneto

R975-C1 ENGINE (CONTINENTAL)

WIRING ORDER	1	2	3	4	5	6	7	8	9
CYL NO.	5R	4R	3R	2R	1R	6R	7R	8R	9R
WIRE LENGTH	64 IN.	59 IN.	51 IN.	44 IN.	36 IN.	50 IN.	44 IN.	38 IN.	32 IN.
									
WIRING ORDER	10	11	12	13	14	15	16	17	18
CYL NO.	5F	4F	3F	2F	1F	6F	7F	8F	9F
WIRE LENGTH	58 IN.	58 IN.	51 IN.	43 IN.	40 IN.	72 IN.	69 IN.	55 IN.	49 IN.
									
MAGNETO BLOCK NO.	3	7	2	6	1	8	4	9	5
SHAPE WIRE END									

RA PD 336205

Figure 100 — Ignition Wire Holding Fixture

**ORDNANCE MAINTENANCE — 9-CYLINDER, RADIAL, GASOLINE ENGINE
(CONTINENTAL MODEL R975-C1)**

end after they have all been installed in the radio shielded conduits. Insert the first wire (cut to length and identified on the end) into the No. 1 hole of the wire-holding fixture.

(3) **IDENTIFY WIRE ENDS.** Continue cutting wires to length, identifying the ends, and inserting in the holding fixture until all 18 wires are ready. Note in figure 100 that the end of the wire is left flat when cutting identification gashes on the first three wires. On the next three, cut the end on a taper, and on the last three, strip $\frac{1}{8}$ to $\frac{1}{4}$ inch of insulation from the end before cutting the gashes. This system provides nine differently identified wire ends for each magneto. Note that in the complete harness of 18 wires, there will be two wires bearing each identifying shape on the end, but among the nine wires in the outlet to either one of the magnetos, each wire will be identified differently from all the others in that same outlet.

(4) **TEST WIRES.** Before installing new ignition wires, they should be electrically tested for leaks or defective insulation. This test may be accomplished with any approved high tension electrical testing equipment. Dust the wire with powdered mica or talc to facilitate installation in the manifold. **CAUTION: Do not use graphite, soap, oil, or grease as a wire lubricant.** Remove only one wire at a time from the holding fixture, and reinstall it in the same position from which it was removed.

(5) **REMOVE FLEXIBLE CONDUITS.** All manifold to spark plug and manifold to magneto flexible conduits will be removed from the main conduit halves before starting to install new wires.

(6) **BEGIN INSTALLATION OF WIRES.** Remove the wire from the first hole in the holding fixture (fig. 100), and insert in the outlet for the rear spark plug of No. 5 cylinder (No. 5 rear, on fig. 101). The identified end of the wire will be inserted first. Push the wire through until it protrudes through the open end of the manifold. Install a rubber grommet over the spark plug end of the wire, with the cone on the grommet toward the manifold, and push it into position in the manifold outlet. Thread one of the short braided spark plug conduits over the remaining length of ignition wire, and tighten to the manifold nipple. Pull the ignition wire out through the open end of the manifold until approximately 6 inches of wire is left exposed at the spark plug end. This is left exposed for installation of the spark plug terminal and elbow.

(7) **INSTALL REMAINING REAR SPARK PLUG WIRES.** Continue installing wires (in the order shown in the chart and in fig. 100) until all five rear spark plug wires for that half of the manifold ring are in place. Then install the four rear spark plug wires in the other half of the manifold ring, bringing the identified ends of these wires out

R975-C1 ENGINE (CONTINENTAL)

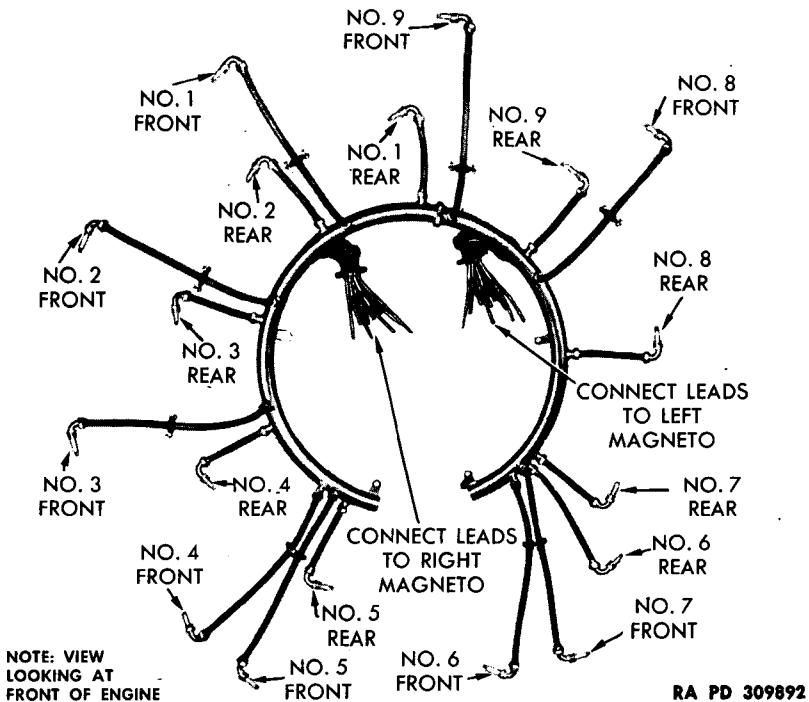

Figure 101 – Ignition Wiring Harness

through the magneto conduit outlet instead of through the open end.

(8) **INSTALL FRONT SPARK PLUG WIRES.** Continuing with No. 10 in the wiring order, install the next five ignition wires and spark plug (front) connectors. Bring these wires out through the magneto conduit outlet in that side of the manifold. Install the remaining four wires and spark plug connectors in the other half of the manifold and bring the magneto ends out of the open end of the manifold.

(9) **CONNECT MANIFOLD HALVES.** Place a new gasket over the wires extending from the open end of the conduit. Thread wires from the two manifold halves together and bring out through the magneto conduit outlets. Tighten the knurled nut to hold the two halves of the manifold together. Arrange wires so that when the magneto elbows and conduits are installed, they will fit into the magneto distributor blocks with a minimum of interference (fig. 102).

(10) **ASSEMBLE TERMINAL ELBOWS.** Install new rubber washers in the spark plug terminal elbows, and insert the spark plug ends of the wires through the elbows. Fasten the elbows with the coupling nuts.

ORDNANCE MAINTENANCE — 9-CYLINDER, RADIAL, GASOLINE ENGINE
(CONTINENTAL MODEL R975-C1)

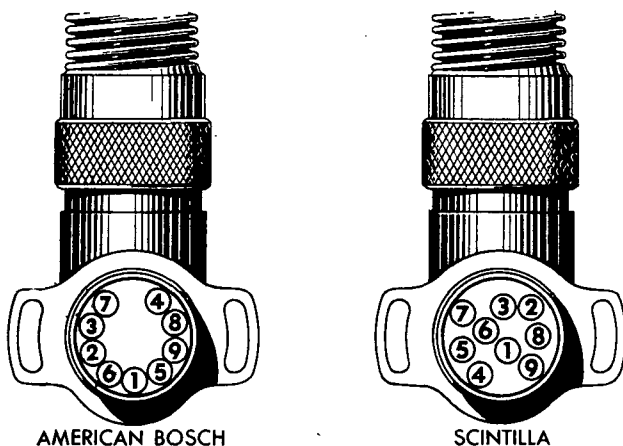

RA PD 309891

Figure 102 — Position of Wires Through Cable Outlet Adapter

(11) **ASSEMBLE TERMINAL CONDUITS.** Install a spark plug shielded terminal contact on the face end of each spark plug wire. To prepare the wires, strip $\frac{5}{16}$ inch of insulation from the ends. When removing the insulation, use care to prevent cutting into the wires. Without bending or twisting the wire strands, slide the terminal contact in position on the ignition wire. Bend the strands back over the wire opening in a flat, radial pattern. Do not solder the wire in position. Wipe the contact and wire clean. As each contact is installed, carefully pull the corresponding wire extending through the magneto outlet until the contact is drawn up snug against the terminal elbow. Be extremely careful to avoid pulling the wire core out of the connector. Immediately after a contact has been installed, attach a protector to the elbow by means of the knurled nut.

(12) **ASSEMBLE MAGNETO CONDUITS.** Using new gaskets, install the magneto conduits over the wires protruding from the two outlets and secure to the manifold. Install new gaskets on the shoulders of the conduit ferrules at the magneto end, thread the wires through the elbows, and secure to the conduits.

(13) **INSTALL FERRULES.** The wire lengths (measured from the face of the magneto elbows) shown in the following chart are for cutting at the distributor block ends. Cut wires, one at a time, to the required length, and strip $\frac{3}{8}$ inch of insulation from the end. Separate the strands, space them evenly, and fold back over the insulation. Install a copper ferrule, stamped with the distributor block number in three places, and swage in place using the tool (41-T-3369-10). Establish identity of each wire by referring to the identification marks

R975-C1 ENGINE (CONTINENTAL)

cut on the ends of the wires before installation in the manifold (fig. 100). Two different magnetos, one a Scintilla and the other an American Bosch, are used on R975-C1 engines. Determine which magneto is to be used on the engine before cutting distributor block ends of the wires.

DISTRIBUTOR BLOCK END WIRE LENGTHS

To Block No.	1	2	3	4	5	6	7	8	9
Scintilla Length	4	5½	4	4	5½	4	5	6½	5
Bosch Length	6	6	6¾	6	6	6	6	6¾	6

(14) **ARRANGE WIRES.** Arrange wires in accordance with the arrangement shown in figure 102. This is done so that the wires can be installed in the distributor block with a minimum of interference. Place a numbered ignition cable marker on the magneto end of each cable at this time.

(15) **CONNECT DISTRIBUTOR BLOCKS.** Remove piercing screws from distributor blocks, install ignition wires, and secure with the piercing screws. Numbers stamped on the copper ferrules correspond to those on the distributor blocks. These numbers represent the firing order of the magneto, not the cylinder locations.

Section VI

OVERHAUL OF THE DIFFUSER SECTION

23. DISASSEMBLY OF THE DIFFUSER SECTION.

a. **Remove Impeller Drive Gear and Support.** Remove the cotter pins, nuts, and flat washers from the four studs that secure the support for the impeller drive gear shaft. Remove the cotter pin and nut from the impeller drive gear shaft and remove the support (fig. 103). Rotate the impeller so that the flange on the rear of the impeller drive gear shaft will clear the radius between the blades of the impeller. Use a fiber drift, and tap the impeller drive gear shaft out toward the rear. Withdraw the impeller drive gear and bearing (fig. 104).

b. **Remove Accessory Drive Idler Gears.** Remove the cotter pins, nuts, flat washers, and spacers from the two accessory drive idler gear studs, and withdraw the gears (fig. 105). Refer to figure 114, and note that a washer is located under each of the idler gears. Remove these washers at this time so that they will not fall out and be lost when the housing is washed.

ORDNANCE MAINTENANCE — 9-CYLINDER, RADIAL, GASOLINE ENGINE
(CONTINENTAL MODEL R975-C1)

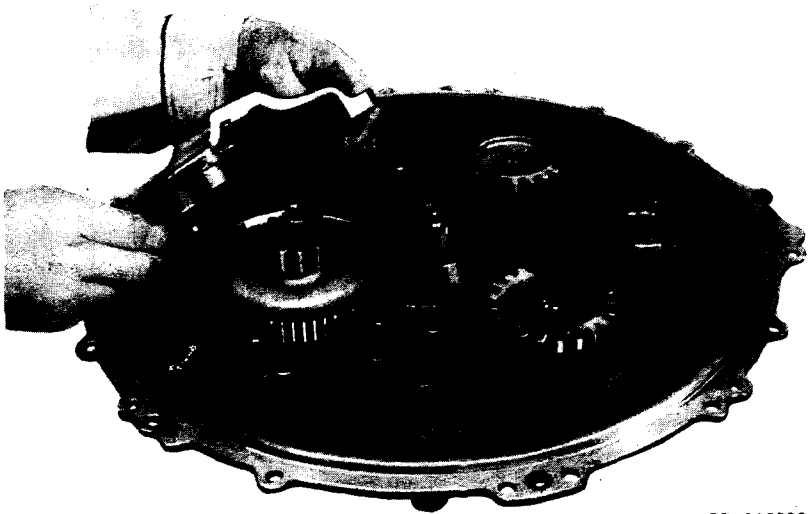

RA PD 309828

Figure 103 — Removing Impeller Drive Gear Support

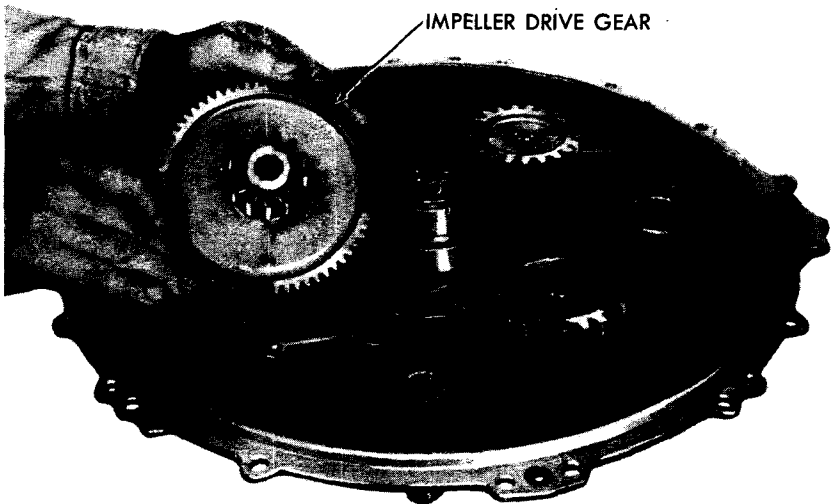

RA PD 309829

Figure 104 — Removing Impeller Drive Gear

c. **Remove Supercharger Impeller.** Install the diffuser section in the fixture, and remove the impeller rear nut lock ring, lock, and nut. To prevent the impeller and shaft from turning while removing the rear nut, hold the front nut with the tool (41-T-3217-100). Install the puller (41-P-2954-600), and remove the impeller (fig. 106).

R975-C1 ENGINE (CONTINENTAL)

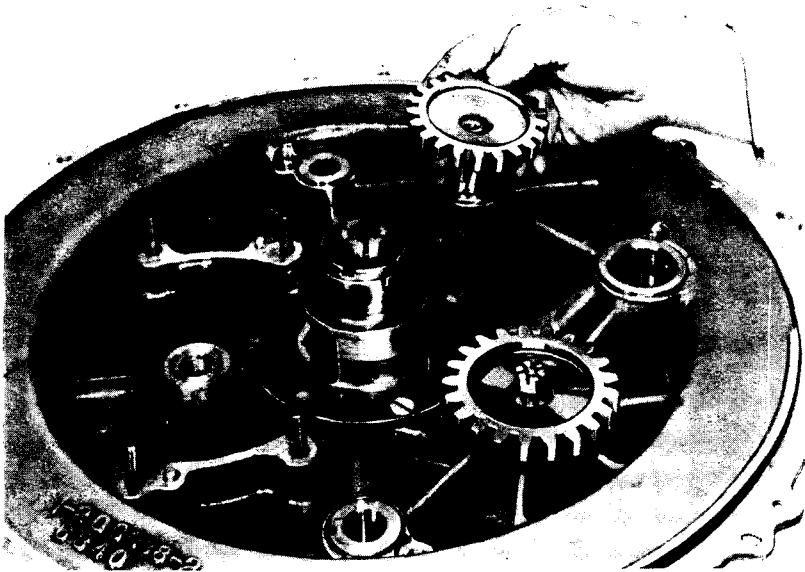

RA PD 309830

Figure 105 – Removing Accessory Drive Idler Gear

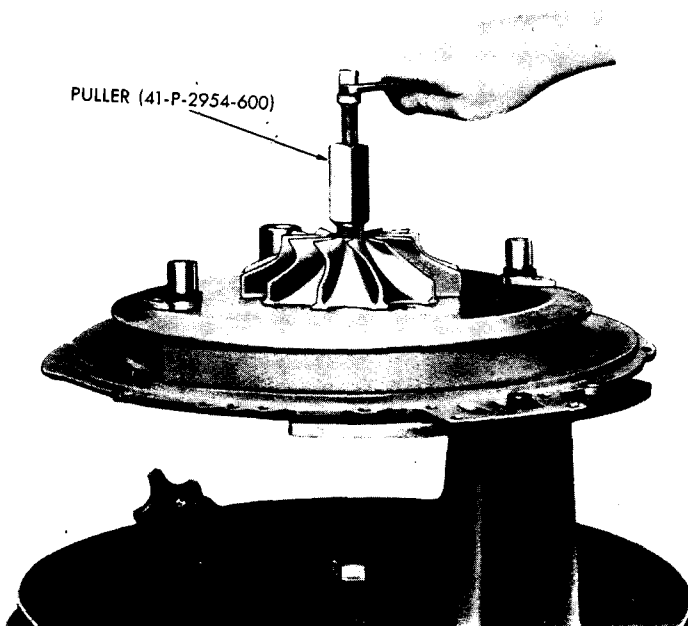

RA PD 309831

Figure 106 – Removing Supercharger Impeller

ORDNANCE MAINTENANCE — 9-CYLINDER, RADIAL, GASOLINE ENGINE
(CONTINENTAL MODEL R975-C1)

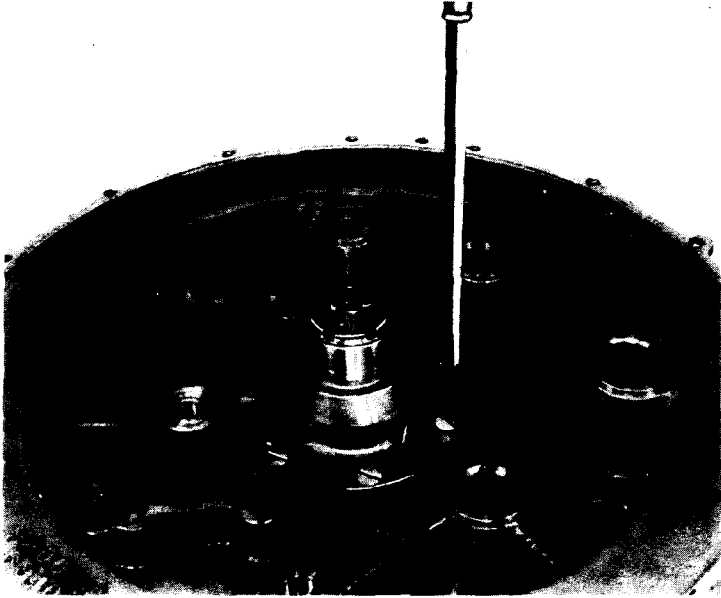

RA PD 309832

Figure 107 — Removing Impeller Drive Shaft Support Screws

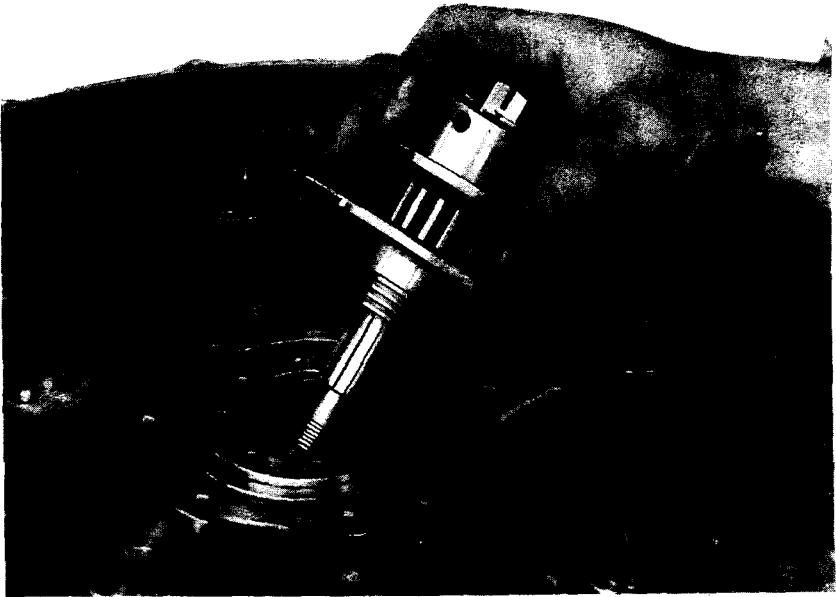

RA PD 309833

Figure 108 — Removing Impeller Drive Shaft and Support Assembly

R975-C1 ENGINE (CONTINENTAL)

d. **Remove Impeller Drive Shaft Gear and Support.** Remove the impeller shaft front ball bearing retainer nut lock ring, and loosen the retainer nut, using the wrench (41-W-1536-250). Remove the seven screws that fasten the impeller shaft front ball bearing support to the front wall of the diffuser section (fig. 107). Withdraw the impeller drive shaft, oil seal spacers, rings, and support, as a unit (fig. 108). If the oil seal rings and spacers stick in the guide, push them out at this time. Hold the impeller shaft stationary in a vise with the locking tool (41-T-3217-100), and remove the front nut lock ring, lock, and nut. Use a brass drift, and tap the impeller shaft and front bearing out of the rear bearing and support. Unscrew the front ball bearing retainer nut, using a wrench (41-W-1536-250). Use a fiber or brass drift, and tap the front bearing out of the support. Remove the shim from the support. Push the front bearing off the impeller shaft in an arbor press.

e. **Remove Spacers and Oil Seals.** Do not remove the diffuser section spacers (fish plates) from the accessory drive shaft bushings unless they are cracked or otherwise damaged. Slide the rubber oil seals off the accessory drive shaft bushings.

24. CLEANING THE DIFFUSER SECTION.

a. **General.** All parts are to be thoroughly washed in dry-cleaning solvent and laid out for inspection. Use a wire brush or scraper to clean out any sludge accumulation from the oil supply annulus around the impeller shaft hole. Blow out all oil passages with compressed air and make sure that none are plugged.

25. INSPECTION OF THE DIFFUSER SECTION.

a. **Inspect Diffuser Section Housing.** The diffuser section housing will be given a careful examination for cracks; note particularly the areas surrounding the stud holes in the flange. See that oil passages are clear and plugs in tight. Examine the bushings for evidence of overheating or other damage, and measure diameters for wear. Check clearance diameters between all shafts and bushings (maximum 0.006 inch loose). All bushings must be tight in the housing.

b. **Inspect Impeller Drive Gear, Bearing, and Support.** Examine the gear teeth faces carefully for heavy pitting or wear of the hardened contact surfaces. Check the bushing and bearing for wear, scoring, or any evidence of overheating. Check the clearance diameter between the bushing and the bearing (maximum 0.006 inch loose). See that the bushing is tight in the impeller drive gear. Inspect machined flanges on the impeller drive gear shaft support for nicks or burs. Check the flat thrust face on the support for grooving caused by the impeller drive gear (fig. 109).

ORDNANCE MAINTENANCE — 9-CYLINDER, RADIAL, GASOLINE ENGINE
(CONTINENTAL MODEL R975-C1)

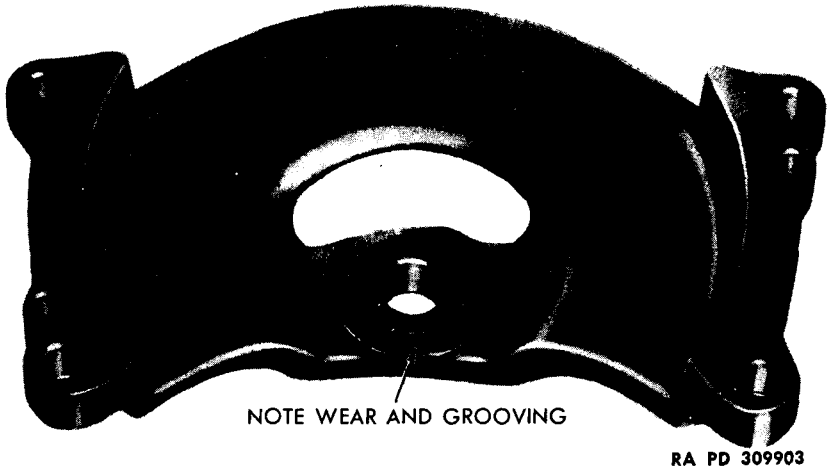

Figure 109 — Impeller Drive Gear Shaft Support

c. **Inspect Impeller Shaft Gear and Bearings.** Check the gear teeth closely for wear, chipping, or pitting of the hardened contact surfaces. Inspect the shaft for galling at the splines and bearing mounts. See that the impeller has not been setting loosely or vibrating on the shaft splines. This shaft and integral gear operate at extremely high angular velocity. The part is accurately balanced; therefore, do not attempt repairs, such as stoning, that could alter this balance. If the part is damaged, or defects are noted, it should be replaced. Both impeller shaft ball bearings will be replaced with new parts at each engine overhaul.

d. **Inspect Impeller Shaft Front Ball Bearing Support.** Examine the support for cracks, and determine if the mounting flange is smooth and flat, with no nicks or burs. Check condition of the threads on the front ball bearing retainer nut, and see that the lugs have not been damaged.

e. **Inspect Supercharger Impeller.** Closely examine the impeller blades for any nicks or burs that may have been caused by entrance of some foreign object into the induction system. Examine the front face for damage caused by insufficient clearance. Repairs that could alter the extremely accurate balance of this part will not be requested unless the necessary equipment is available for dynamic balancing. The slightest amount of unequal weight distribution will seriously affect the life and performance of this part.

f. **Inspect Oil Seal Rings and Ring Container.** New oil seal rings are to be installed at each engine overhaul, so the old rings will

R975-C1 ENGINE (CONTINENTAL)

be removed and discarded. Examine the ring spacers to determine that they have not been grooved or overheated. See that all carbon and oil sludge deposits have been cleaned from the spacers. The oil seal ring container is machined as an integral part of the impeller shaft rear ball bearing cage. Check the ring container for any signs of overheating. Look for grooves that may have been worn into the container by spinning of the rings. Replace any bearing cage in which the ring container appears damaged.

g. Inspect Cranking Motor, Cam, and Accessory Driving Gears. Inspect the gear teeth carefully for chipping, pitting, or abnormal wear of the case hardened contact surfaces. Check the bearing diameters and thrust faces for damage.

26. REPAIR OF THE DIFFUSER SECTION.

a. Repair Diffuser Section Housing.

(1) **REPLACE ACCESSORY DRIVE IDLER GEAR BUSHING.** Remove the idler gear stud with the special wrench (41-W-1536), and bore out the old bushing until only a thin shell remains. Collapse the shell, exercising care to prevent damaging the housing, and remove the remaining pieces. Clean up any roughness or galling in the housing bore, and check inside diameter for comparison with the new bushing outside diameter to ascertain if the proper fit (0.001 to 0.003 inch tight) will be provided. Cool the new bushing in dry ice, and heat the housing in a flameless oven to 285°F. Aline oilhole in the bushing with that in the housing, and press the bushing into position. Determine that the bushing flange is seated firmly against the housing before the housing cools. Plug the oilhole with a small globule of heavy grease, and ream the new bushing to size, using a 0.9995 to 1.0005-inch reamer. Exercise care to prevent striking the bottom of the hole in the housing with the reaming tool. Remove the grease and blow out all chips. Break all sharp edges on the bushing. Apply gasket cement to the head of the idler gear stud, and reinstall in the housing. Wipe off any excess gasket material from the stud.

(2) **REPLACE ACCESSORY DRIVE SHAFT BUSHING.** Bore out the old bushing until only a thin shell remains, and collapse the shell. Remove the remaining pieces of the bushing and the locking pin, using care to prevent damaging the housing. Clean up any galling or roughness in the bushing bore of the housing, and check the bore diameter to see that the proper amount of press fit (0.001 to 0.003 inch tight) will be provided. Cool the new bushing in dry ice, and heat the housing in a flameless oven to 285°F. Press the bushing into position, and determine that the flange is well seated before allowing the housing to cool. Remove the oil passage plug from the outside rim of the housing, and drill a new hole all the way through

**ORDNANCE MAINTENANCE — 9-CYLINDER, RADIAL, GASOLINE ENGINE
(CONTINENTAL MODEL R975-C1)**

both sides of the bushing, using a 0.190-inch drill. Use a No. 31 (0.120-inch) drill, and drill a new locking pin hole through the housing boss and the new bushing. Insert the locking pin and peen metal over on the outside to hold in place. Install the diffuser chamber oil seals and spacers in place, and assemble the rear and diffuser sections together. Line ream the new bushing, using the fixture (41-F-2987-210) and the reamer (41-R-390) (fig. 123). Check fit of the shaft in the bushing (0.0025 to 0.0045-inch clearance), and measure end clearance with the gear installed (0.012 to 0.050 inch). Spot face the bushing flange if necessary to obtain the specified amount of end clearance. Separate the parts and blow out all chips. Coat a new plug for the oil supply hole to the bushing with sealing compound, install in place, and stake securely. Break all sharp edges, and clean the parts thoroughly.

(3) **REPLACE CRANKING MOTOR DRIVE GEAR BUSHING.** The worn or damaged bushing will be removed and a new one installed in the same manner as outlined for the accessory drive. Lock the new bushing in place by drilling a new hole, piloting the drill (No. 31 to 0.120 inch) through the pinhole in the housing boss, and inserting a lock pin. Peen the metal over on the outside to hold in place. Plug the oilhole with heavy grease, and line ream the bushing, using reamer (41-R-2324). Break all sharp edges, and remove grease and chips from the oilhole.

(4) **REPAIR HOUSING.** Stone to smooth over any nicks or burs on the machined parting flanges or bushing flanges, and polish with crocus cloth. Light scoring of the bushings can, in some cases, be corrected by polishing with crocus cloth. Ordinarily if the bushing is scored, it will be replaced.

b. Repair Impeller Drive Gear, Bearing, and Support.

(1) **DRIVE GEAR BUSHING REPLACEMENT.** Drill out the lock pin, and push the old bushing out of the gear with an arbor press. Clean up galling or roughness of the bushing bore in the gear, and measure diameters to determine that specified press fit (0.001 to 0.003 inch) will be provided. Heat the gear in a flameless oven to 285° F, and cool the new bushing in dry ice. Assemble the bushing from the large gear end of the impeller drive gear so that the flange on the bushing will be at the large gear end when installed in place. Be sure the flange on the bushing is fully seated before the gear cools. Drill a new locking pinhole through the bushing, using a slightly undersize drill and the old hole in the gear as a guide. Ream the hole to 0.091- to 0.093-inch diameter, and insert the locking pin. Peen metal of hub over hole after inserting the pin. Center the gear in a boring machine by indicating over 0.1500-inch diameter rolls

R975-C1 ENGINE (CONTINENTAL)

placed between the teeth of the large gear. Bore out the bushing to an inside diameter of 1.1250 to 1.1255 inches. Face off the bushing flange, if necessary, so that the distance measured from the face of the bushing to the face of the small gear end is 1.795 to 1.799 inches. The bushing bore must be concentric and parallel with the pitch diameters of the gears within 0.003-inch full indicator reading.

(2) **REPAIR IMPELLER DRIVE GEAR HUB BEARING.** Very light scratching or scuffing of the hub bearing can be polished over with crocus cloth wetted in dry-cleaning solvent or clear gasoline. However, if the bearing is heavily scratched or shows evidence of overheating or abnormal wear (maximum 0.006-inch clearance), it is to be replaced with a new part.

c. Repair Impeller Shaft Gear and Bearings. Remove external galling from the splines and bearing locations, and polish with crocus cloth. The sides and bottom of the splines must not be stoned, as the impeller must be a tight fit.

d. Repair Impeller Shaft Front Ball Bearing Support. Remove any slight nicks or burs with a fine stone. If the mounting flange is warped or heavily nicked, the part should be replaced. Do not attempt to correct a warped flange by reworking on a lapping block, as alinement of the impeller shaft ball bearings will be thereby affected.

e. Repair Supercharger Impeller. Precision machinery is required for dynamic balancing of supercharger impellers; therefore, stoning or other repairs that could materially alter the distribution of weight in the impeller should not be attempted if the balancing equipment is not available. It is much safer to reinstall an impeller which has been nicked slightly than to use one in which the nicks have been stoned out without rebalancing the impeller. Light internal galling of the splines should be smoothed over with a fine stone, but use care to avoid stoning the splines undersize. The impeller must be a tight fit on the impeller shaft.

f. Repair Oil Seal Rings and Ring Container. New oil seal rings are to be installed at each overhaul. Check ring gap when installed in the ring container for comparison with specifications (0.000 to 0.006 inch). The ring container, which is an integral part of the rear ball bearing cage, should be replaced if it has been grooved or overheated during previous engine operation. Use a fine stone to remove any galling from the ball bearing location of the cage. Oil seal spacers will be polished with crocus cloth and gasoline to remove any hard carbon deposits or slight nicks. Do not smooth up spacers on a lapping block, or the thickness may be reduced to the extent that insufficient clearance is provided for the oil seal rings.

**ORDNANCE MAINTENANCE — 9-CYLINDER, RADIAL, GASOLINE ENGINE
(CONTINENTAL MODEL R975-C1)**

g. Repair Cranking Motor, Cam, and Accessory Driving Gears. Stone to remove any slight nicks and burrs from all gears. Repairs that will materially alter the shape or contour of any gear teeth are not to be attempted. If a gear tooth has worn or been damaged to the extent that considerable material will have to be removed to smooth up, the part will be replaced. Polish bearing pilots on the gears with crocus cloth wetted in dry-cleaning solvent or clear gasoline. If the bearing pilots are heavily scratched or show any evidence of overheating, replace the gear.

27. ASSEMBLY OF THE DIFFUSER SECTION.

a. Assemble Accessory Drive Shaft Spacers and Oil Seals. Slide oil seal retainers flanged end up, over the accessory drive shaft bushing extensions and down against the diffuser housing. If fish plate spacers have been removed, they should be assembled at this time. Insert the fish plate retaining screws, tighten, and stake securely in place. Assemble a new oil seal over each of the accessory drive shaft bushing extensions and down against the oil seal retainers.

b. Assemble Impeller Shaft Rear Ball Bearing Cage. If the impeller shaft rear ball bearing cage has been removed and discarded, the new part is to be assembled at this time. Place a small quantity of lapping compound on the bearing cage flange and lap into the diffuser section. This is done to provide a flat, even contacting surface and prevent misalignment and consequent distortion of the ring guide portion of the cage. Wash all traces of lapping compound off the parts. A bronze shim and two thin paper gaskets set between the cage and the diffuser section housing. Aline holes, and place a new gasket against the bearing cage. Place the bronze shim and another gasket over the first gasket, and insert two of the retaining screws through holes in the cage flange to hold the parts together and in alinement. Aline holes in the gasket and cage assembly with tapped holes in the diffuser section housing, and insert in place. Install and tighten the eight retaining screws, and secure with lock wire. The lock wire will be kept below the tops of the screw heads to prevent interference with the impeller.

c. Assemble Impeller Drive Shaft Gear and Support. Assemble a new rear ball bearing over the splined end of impeller shaft with the side marked "GEAR SIDE" against the gear. If necessary, use a hollow arbor that will clear the impeller shaft and contact only the inner race of the bearing to push the bearing on until the inner race seats solidly on a shoulder on the gear. Place the impeller shaft front bearing shim (fig. 110) in the support, and assemble a new

R975-C1 ENGINE (CONTINENTAL)

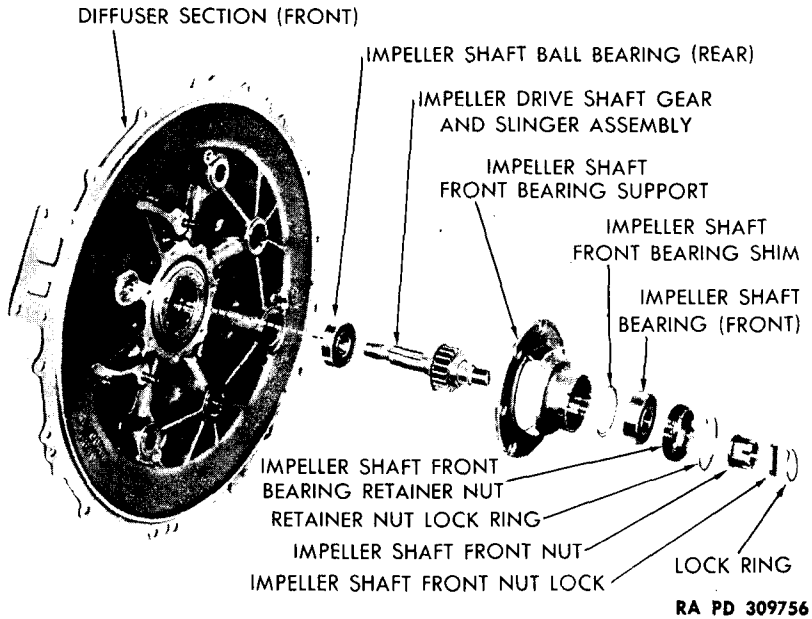
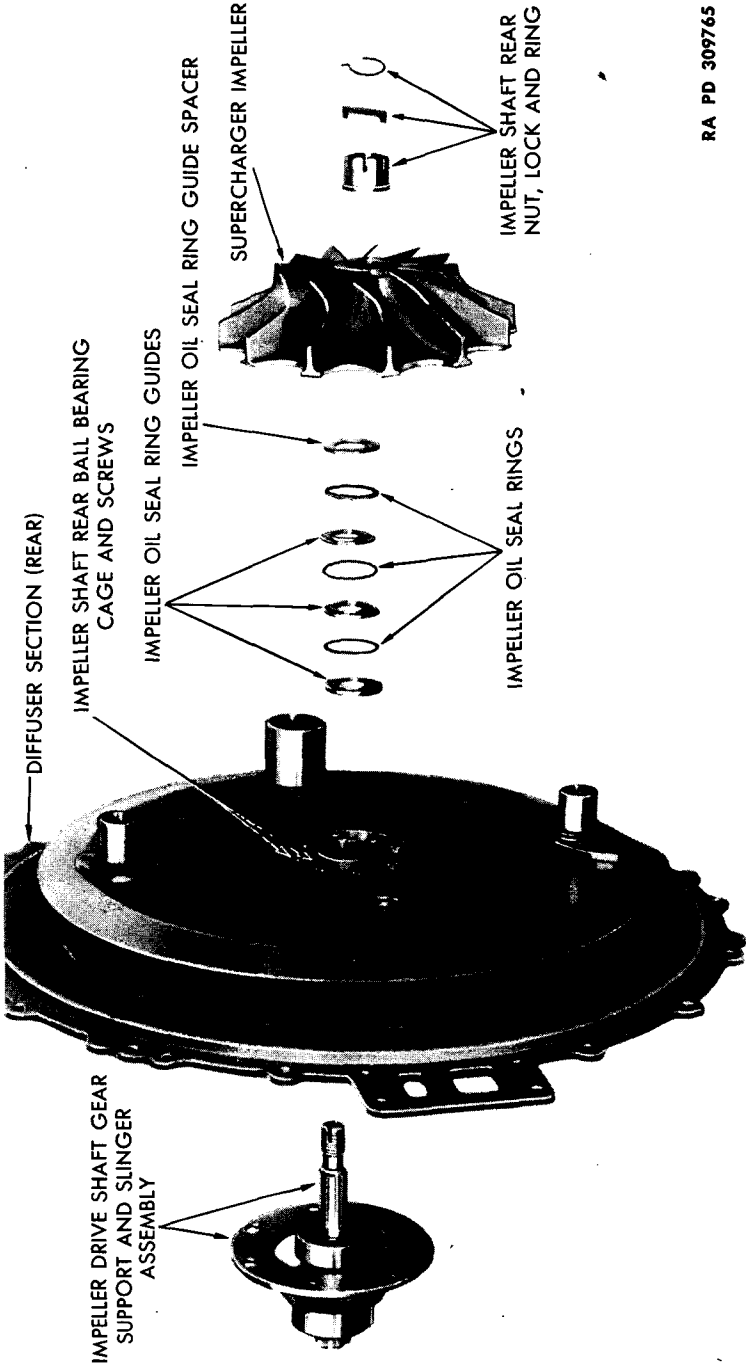

Figure 110 — Impeller Drive Shaft Gear and Support Disassembled

impeller front bearing with the side marked "GEAR SIDE" facing in or toward the flanged end of the support. Install the bearing retainer nut, and tighten snugly by hand. Set the splined end of the impeller shaft in the locking tool (41-T-3217-100), and assemble the front bearing and support assembly. Install the impeller shaft front nut and tighten securely. Assemble a used nut lock at this time. Use a new gasket, and assemble the bearing support and shaft assembly to the diffuser section housing. Insert the retaining screws, tighten securely, and stake in place. Tighten the front bearing retainer nut using the lug wrench (41-W-1536-250). Install the oil seal ring guide over impeller shaft within the bore of the rear ball bearing cage, flat face down (fig. 111). Insert an oil seal ring in a similar manner using fingers only. If the ring fails to enter the bore of the bearing cage because of insufficient gap clearance, remove, widen gap, and reinsert, checking carefully with a feeler gage to determine that the gap clearance is within the specified limit (0.000 to 0.006 inch). Under no circumstances should the rings be forced into position because of insufficient gap clearance, because this will cause damage to the contact surface and will result in oil leakage. Repeat this procedure after installing each of the remaining two guides. Lubricate the rings with a liberal supply of engine oil.

ORDNANCE MAINTENANCE — 9-CYLINDER, RADIAL, GASOLINE ENGINE
(CONTINENTAL MODEL R975-C1)



RA PD 309765

Figure 111 — Supercharger Impeller and Shaft Partially Disassembled

R975-C1 ENGINE (CONTINENTAL)

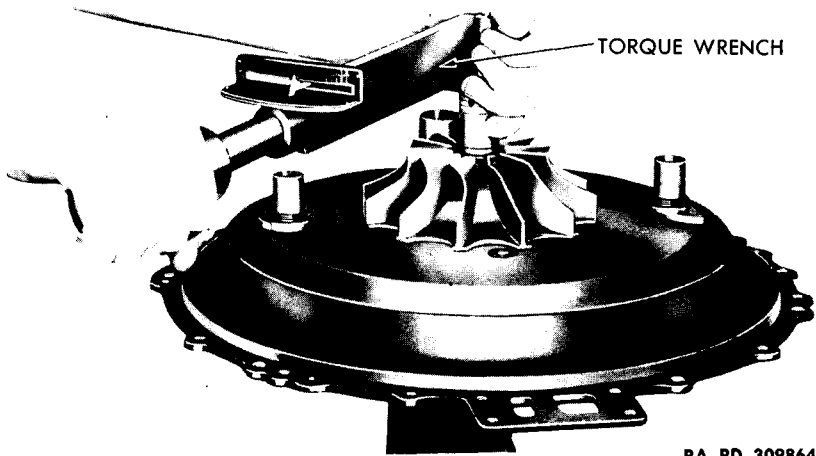

RA PD 309864

Figure 112 – Tightening Impeller Rear Nut

d. **Assemble Supercharger Impeller.** Place a little graphite on the impeller shaft splines and assemble the impeller. The impeller must be a tight fit on the shaft. A proper fit is obtained with an impeller which may be installed approximately halfway by hand. Tap the impeller onto the shaft until the nut can be installed, and tighten the nut (fig. 112). Hold the shaft stationary with the locking tool (41-T-3217-100) while tightening the nut. Check clearance by inserting feeler gages between the under side of the impeller and the diffuser chamber wall (minimum 0.022 inch, maximum 0.032 inch). If clearance is not within specifications, it will be necessary to remove parts and change the shim under the front ball bearing. To decrease clearance, use a thicker shim. Use only one shim under the bearing. Reassemble the parts, and again check the clearance. If clearance is within specified limits, install new nut locks on each end of the impeller, and secure with lock rings. Secure the front bearing retainer nut with a lock ring.

e. **Assemble Impeller Drive Gear and Support.** Insert the impeller drive gear hub bearing in the gear from the large gear end (fig. 113). Place the gear and hub bearing in position, aligning the key slot (not the oil groove) in the hub bearing, with the key slot in the diffuser section housing. Tap the key in the slot in the impeller drive gear shaft, and apply a light coating of gasket material to the flange of the shaft head. Insert the shaft in position from the rear side of the diffuser section. Place the shaft support in position, and

ORDNANCE MAINTENANCE — 9-CYLINDER, RADIAL, GASOLINE ENGINE
(CONTINENTAL MODEL R975-C1)

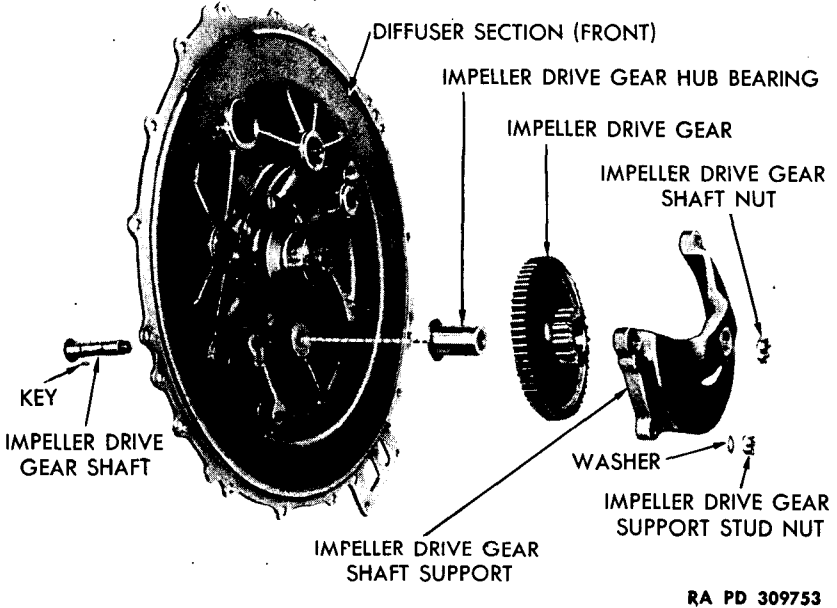

Figure 113 — Impeller Drive Gear, Shaft, and Support Disassembled

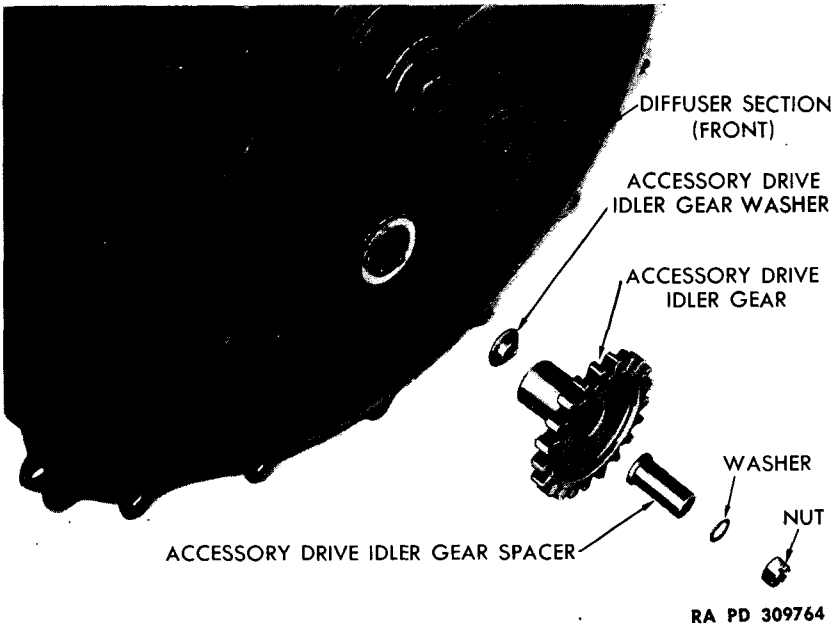

Figure 114 — Accessory Drive Idler Gear

R975-C1 ENGINE (CONTINENTAL)

screw on the shaft nut. Assemble flat washers and nuts on the four support attaching studs. Tighten the nuts, and secure with cotter pins. Tighten the drive gear shaft nut, and lock it with a cotter pin.

f. **Assemble Accessory Drive Idler Gears.** Insert the flanged accessory drive idler gear washer over the stud and into the housing (fig. 114). Note that the washer is inserted flanged end first. Assemble the gear, and insert the spacer flanged end first. Lay a flat washer over the spacer, and tighten the nut in position. Secure the nut with a cotter pin. Note carefully the position in which these parts are to be installed. Make sure the gear turns freely when the nut has been fully tightened. Assemble the remaining accessory drive idler gear in the same manner.

g. **Final Assembly Parts.** The remaining diffuser section parts will not be installed until final assembly of the engine.

Section VII

OVERHAUL OF THE REAR SECTION

28. DISASSEMBLY OF THE REAR SECTION.

a. **Disassemble Tachometer Drive.** Unscrew the two bronze bushings, and withdraw the tachometer drive gear and sleeve assemblies. Remove lock wire and the six screws that fasten the cover to the housing, and lift off the cover. Using a fiber hammer, tap lightly on the protruding end of the tachometer drive shaft to drive the shaft out together with two ball bearings. Unless inspection indicates the need for replacement, the two ball bearings will not be removed from the drive shaft.

b. **Disassemble Main Oil Pump.** Lift off the oil pump bevel drive gear, and remove the screws that attach the pressure pump body to the scavenge pump body (fig. 130). Remove the pressure pump body, and withdraw the oil pump drive shaft, driven shaft, and the gears. Separate the scavenge pump gears, the spacer, and the pressure pump parts. Unscrew the oil thermometer adapter, and withdraw the spring and screen (fig. 131). Remove the relief valve cap, and unscrew the valve body, using wrench (41-W-636-620) (fig. 115). Back the adjusting screw out of the body, and remove the remaining relief valve parts (fig. 132). Remove palnuts, nuts, washers, and cover from the bottom of the oil pump body. Withdraw the governor drive shaft and intermediate gear.

c. **Disassemble Three-way Accessory Drive Housing.** Remove palnuts, nuts, flat washers, and cover from the vacuum pump adapter.

ORDNANCE MAINTENANCE — 9-CYLINDER, RADIAL, GASOLINE ENGINE
(CONTINENTAL MODEL R975-C1)

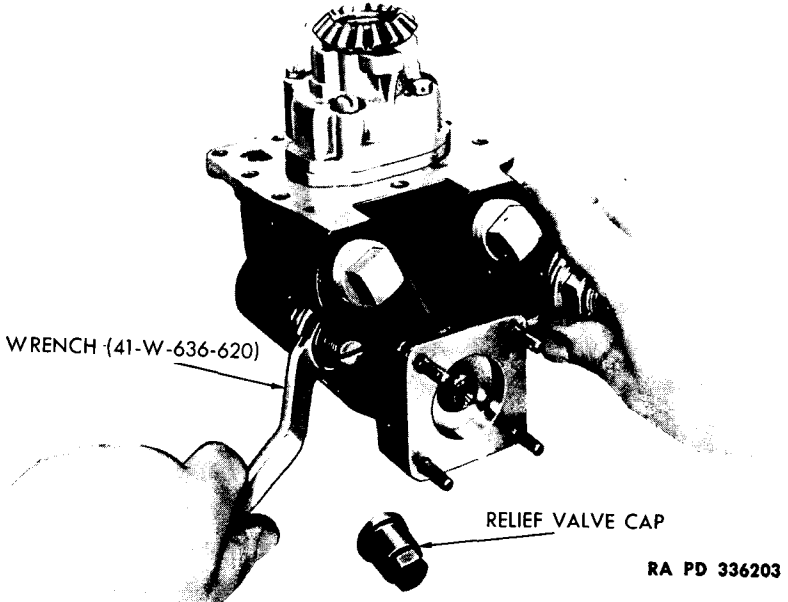

Figure 115 — Removing Oil Pressure Relief Valve

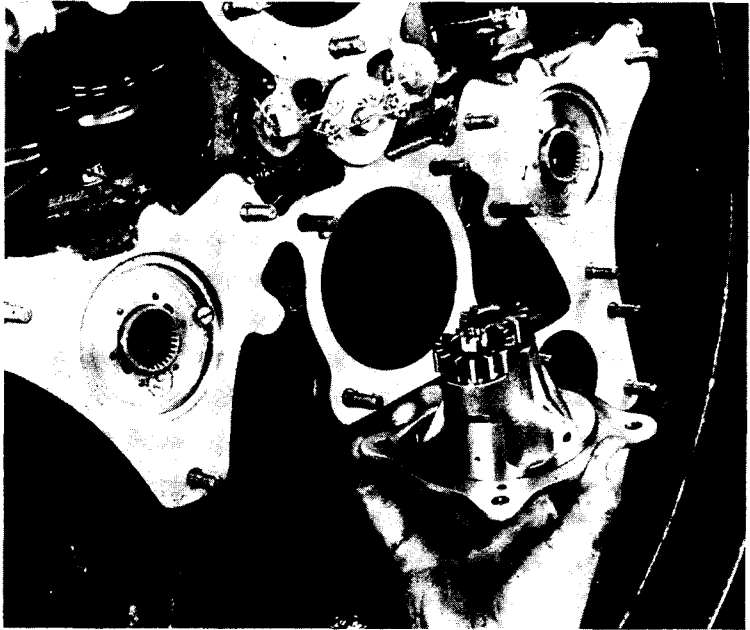

Figure 116 — Removing Generator Drive Gear Assembly

R975-C1 ENGINE (CONTINENTAL)

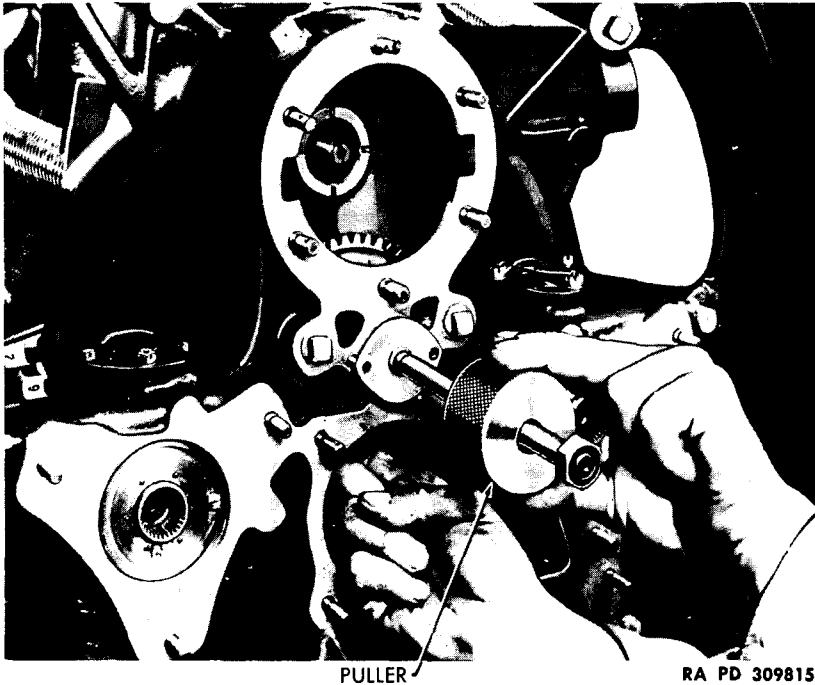

Figure 117 – Removing Generator Idler Gear Shaft

Withdraw the adapter together with the vacuum and fuel pump drive shaft. Should it be necessary to use a fiber hammer to assist removal of the adapter, tap lightly around the edges, and avoid striking at or near machined parting flanges. **CAUTION:** *Do not use a screwdriver or other tool to pry under the adapter.*

d. Disassemble A-C Fuel Pump and Adapter. Remove lock wire, nuts, and washers that attach the pump to the adapter, and withdraw the pump (fig. 128). Remove lock wire and screws holding the drive shaft bushing adapter to the pump adapter, and pull out the bushing adapter and fuel pump drive shaft.

e. Disassemble Generator Drive Gear Support. Remove the generator drive gear support assembly by withdrawing over the four studs in the rear of the crankcase rear section (fig. 116). Pry out the lock ring, and remove the generator drive gear nut (fig. 127). Block the gears from turning with a fiber wedge placed between the two gears on the inner end of the support while loosening the nut. Remove cotter pin, nut, and washer from the intermediate gear stud, and withdraw both gears.

ORDNANCE MAINTENANCE — 9-CYLINDER, RADIAL, GASOLINE ENGINE
(CONTINENTAL MODEL R975-C1)

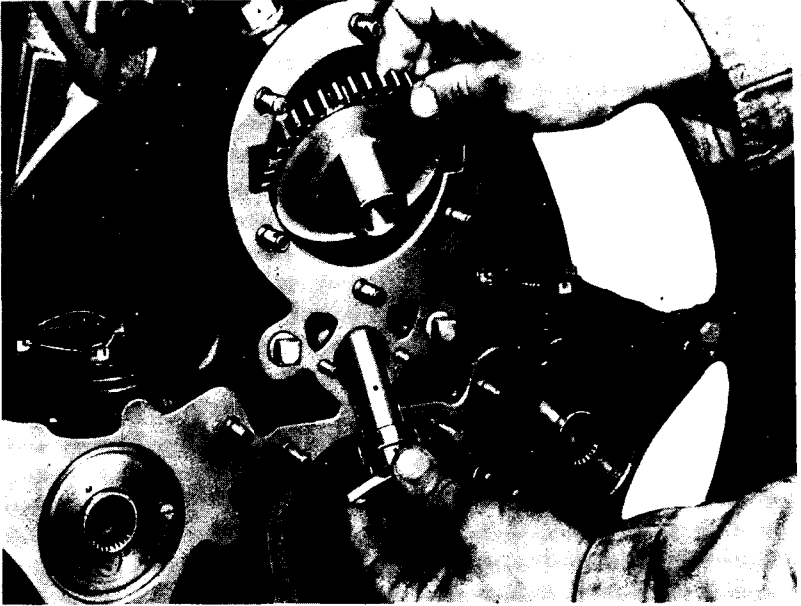

RA PD 309770

Figure 118 — Removing Generator Idler Gear

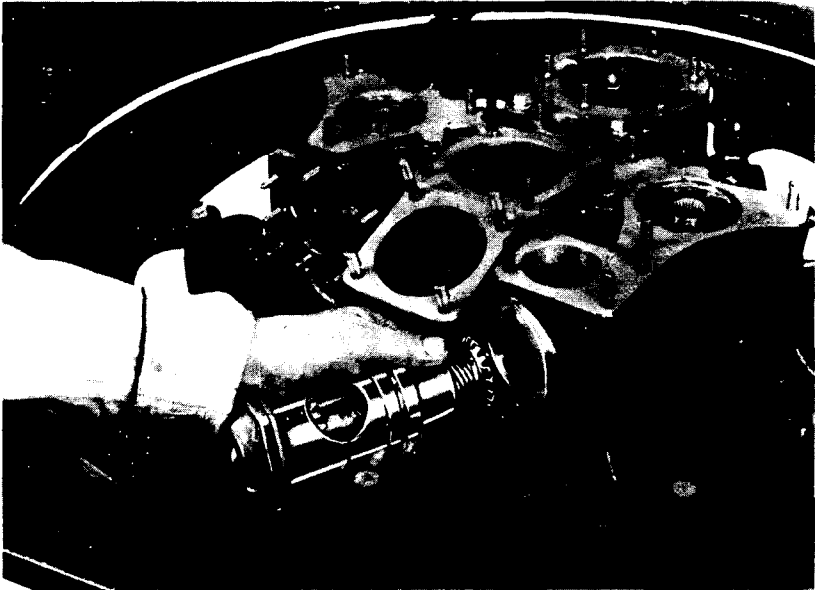

RA PD 309816

*Figure 119 — Removing Tachometer and Three-way Accessory
Drive Adapter*

R975-C1 ENGINE (CONTINENTAL)

PULLER (41-P-2951-11)

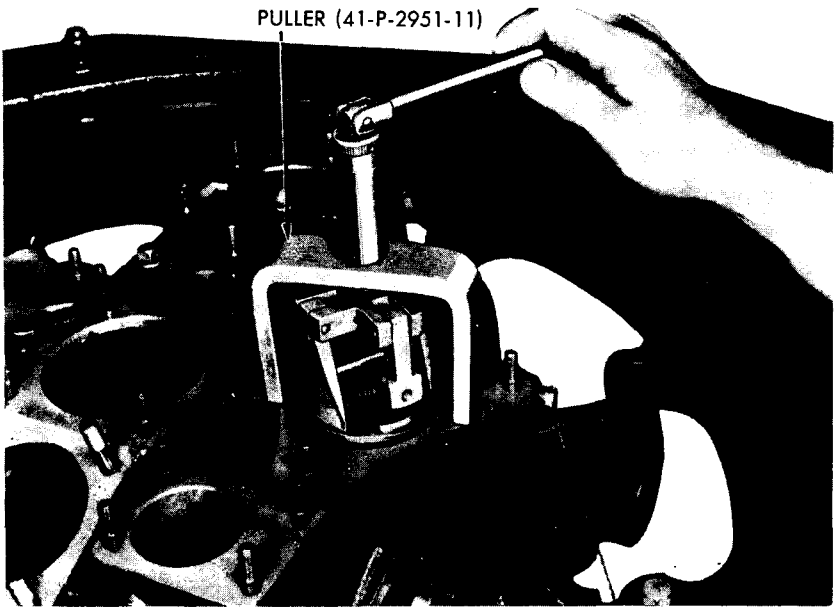

RA PD 309817

Figure 120 — Removing Magneto Drive Oil Seal

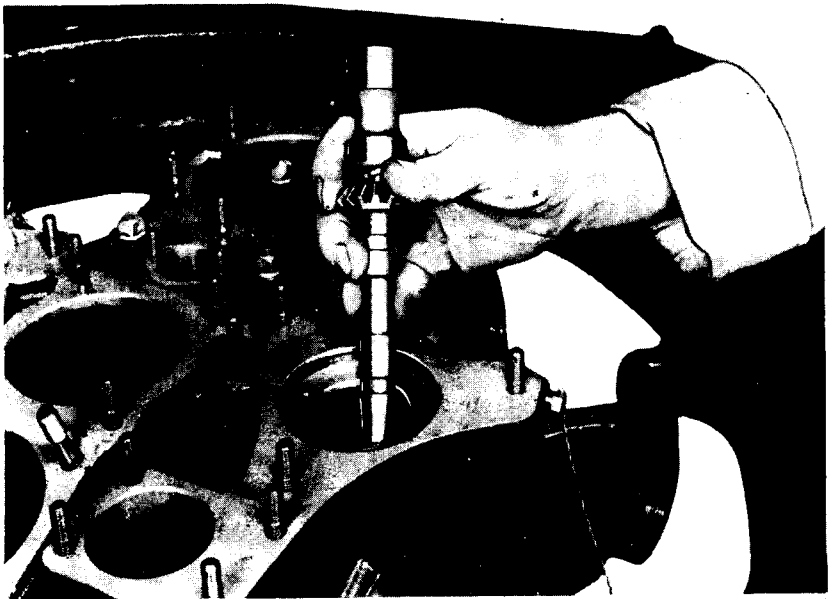

RA PD 309818

**Figure 121 — Removing Accessory Drive Shaft Assembly
(Magneto Drive)**

ORDNANCE MAINTENANCE — 9-CYLINDER, RADIAL, GASOLINE ENGINE
(CONTINENTAL MODEL R975-C1)

f. **Remove Generator Idler Gear.** Remove the lock wire, nuts, and washers that fasten the generator idler gear shaft flange to the rear section. Back out the plug, install the puller, and withdraw the shaft (fig. 117). Support the gear while removing the shaft. Withdraw the gear through the cranking motor mounting pad hole (fig. 118).

g. **Disassemble Tachometer and Three-way Accessory Drive Adapter.** Remove the lock wire, nuts, and washers that retain the three-way accessory drive adapter and cover. Remove the cover, and withdraw the adapter, drive gear, and drive gear shaft as a unit (fig. 119). Remove the cotter pin, nut, and washer from the drive gear shaft, and disassemble the gears from the adapter (fig. 125).

h. **Remove Accessory Drive Shafts (Magneto Drives).** Remove lock screws from the two oil seal assemblies located at the magneto mounting pads, and, using puller (41-P-2951-11), pull out the seals (fig. 120). Withdraw the accessory drive shafts from the rear section (fig. 121). It will not ordinarily be necessary to disengage the extension from the accessory drive shaft.

29. CLEANING THE REAR SECTION.

a. **General.** All parts are to be thoroughly washed in dry-cleaning solvent and laid out for inspection. Use a wire brush to dislodge sludge or heavy oil deposits. When washing the housing, flow dry-cleaning solvent through all of the drilled oil passages and blow out with dry compressed air. Remove any gasket material or sealing compound that may still be adhering to the parting flanges. After washing the accessory drive shaft oil seals, soak them in a bath of engine oil to keep the leather soft and pliable.

30. INSPECTION OF THE REAR SECTION.

a. **Inspect Crankcase Rear Section Housing.**

(1) **EXAMINE CASTING.** Examine the casting thoroughly for cracks. Use a strong light, and check carefully around the stud locations and engine mounting bolt holes. See that all studs and oil plugs are tight and in good condition. Examine the mounting flanges carefully for nicks or burs that could cause misalignment or oil leakage.

(2) **CHECK OIL PASSAGES.** There are four bored diameter piloting surfaces in the rear section into which drilled pressure oil lines open. These are the generator idler shaft hole, the generator drive gear support pilot, the three-way accessory drive adapter upper pilot, and the three-way accessory drive housing pilot hole. It is important that the finished inside diameter of the bore in each of these locations

R975-C1 ENGINE (CONTINENTAL)

be smooth and free from all nicks, burs, or scratches near the drilled pressure oilholes. Otherwise, engine oil under pressure will be forced through the damaged section and either out of the engine or into the return oil system, thereby causing high oil flow through the engine pump and possibly more serious difficulties. Refer to figure 6, and note location of drilled oil passages in the rear section.

(3) **CHECK BUSHINGS.** Check condition of the cranking motor and accessory drive shaft bushings. Measure inside diameters, and compare with outside diameters of the shafts to determine that clearances are in accordance with specifications (maximum 0.006-inch clearance). See that the bushings are tight in the casting.

b. Inspect Tachometer Drive. Examine the housing for cracks, and note condition of the threads and machined flanges. See that the ball bearing pilot diameters are not burred or heavily galled. Check condition of gear teeth on the drive shaft and drive gears. Inspect the ball bearings on the drive shaft, and replace if rough spots that will not wash out are found. Use new gaskets, install and tighten the drive gears and bushings, and check end clearance of the drive gears to compare with specifications (maximum 0.052 inch). Excessive end clearance here may be caused by wear of the housing, the bronze bushings, or the gears themselves. See that spiral oil grooves on the gear sleeves are clean and free from nicks or burs. **NOTE:** *Mark upper gear and housing to assure that oil grooves on sleeves rotate in proper direction so that oil is forced in towards gear.*

c. Inspect Main Oil Pump.

(1) **EXAMINE HOUSING.** Examine the housing closely for cracks, and see that all machined surfaces are free from nicks and burs. Inspect surface condition of the oil gear chambers in both sections of the housing. Deep scratches or excessive wear (pressure pump 0.003-inch maximum clearance, scavenge pump 0.005-inch maximum clearance) of the walls in these chambers increases the amount of oil slippage past the gears when the pump is operating. If there are indications that the gears have been rubbing the housing walls, it is probable that the shafts have worn and enlarged the bearings in which they are supported. See that the gear shafts fit properly in their bearings, and the gears are not scuffing or scratching where they bottom in the housings. Check the three bevel gear thrust locations on the housing for grooving or abnormal wear (wear denoted by backlash of over 0.020 inch between gears when assembled).

(2) **CHECK SPACER PLATE.** The spacer plate should be flat and free from nicks or burs. See that it has not been scuffed by the ends of the oil pump gears.

**ORDNANCE MAINTENANCE — 9-CYLINDER, RADIAL, GASOLINE ENGINE
(CONTINENTAL MODEL R975-C1)**

(3) **INSPECT GEARS.** The gears must be free from nicks, burs, or sharp edges. Examine the contacting faces of the gears for pitting, galling, or wear of the case hardened contact surfaces. Note particularly that the tops of the teeth are flat and smooth.

(4) **CHECK STRAINER.** Examine the strainer and spring to determine that the parts are clean and show no evidence of damage.

(5) **INSPECT RELIEF VALVE.** Inspect all parts of the pressure relief valve, and note that none are nicked or burred. If the ball is pitted, it must be replaced.

d. Inspect Three-way Accessory Drive.

(1) **EXAMINE HOUSING.** Examine the housing carefully for cracks, and see that all machined surfaces are free from nicks, burs, and scratches. See that all studs are secure and in good condition. It is particularly important that piloting diameters for the accessory drive adapters be free from scratches in the vicinity of the drilled pressure oilholes. Scratches leading away from the oilholes will permit release of the pressure oil and cause high oil flow.

(2) **INSPECT FLANGES.** Inspect machined flanges on the adapters for nicks or burs. See that the adapters are not cracked, noting locations around the stud holes in particular. Piloting surfaces on the adapters must be smooth and free from nicks or scratches. Examine bushings for scratching or indications of overheating due to lack of sufficient lubrication. Measure inside diameters of the bushings for wear, and compare with specifications (fuel pump maximum 0.006-inch clearance, vacuum pump maximum 0.005-inch clearance).

(3) **EXAMINE GEARS.** Examine splines, bearing diameters, and tooth contact faces on the three-way accessory drive gears for abnormal wear (note clearance diameters) or pitting of the hardened surfaces. Look for indications of overheating on the bearing journals.

e. Inspect Generator Drive Gear Support. Inspect the bushings closely for damage, abnormal wear (maximum 0.006-inch clearance), or evidence of overheating. See that locations around both ends of the drilled oil passage are free from nicks, burs, and scratches (fig. 122). Examine contact surfaces on the gear teeth, and see that the shafts show no evidence of excessive wear (note clearance diameters) or overheating.

f. Inspect Generator Idler Gear and Shaft. Examine tooth surfaces on the gear for wear or pitting. Check bushings to see that they are tight in the gear, and measure inside diameters for comparison with the shaft diameter (maximum 0.005-inch clearance). Inspect the shaft to see that drilled oilholes are clear, and look for

R975-C1 ENGINE (CONTINENTAL)

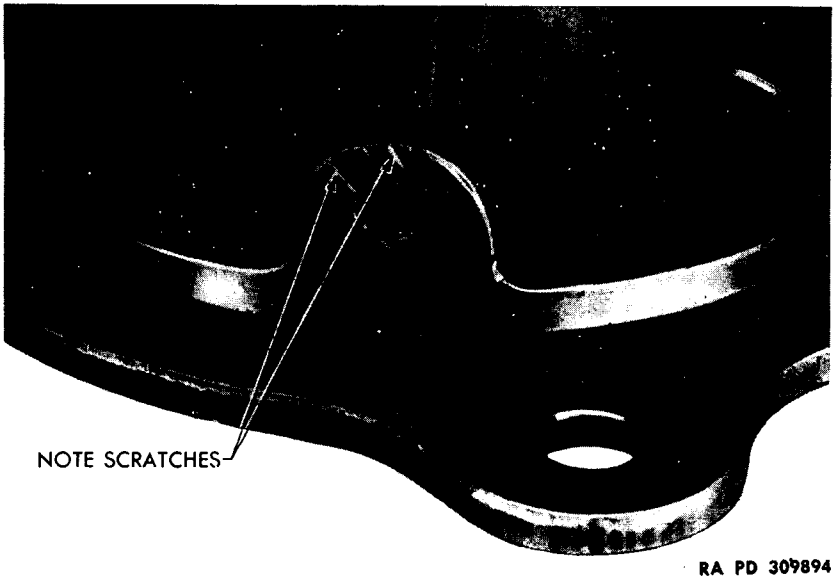

Figure 122 — Generator Drive Gear Support

nicks or burs, particularly around the piloting diameter at the flanged end.

g. Inspect Tachometer and Three-way Accessory Drive Adapter. Inspect condition of the upper piloting diameter surface on the adapter for scratches or other damage on either side of the annular oil groove. Grooves, scratches, or galling in this location will permit oil under pressure to be forced out and into the drain system, thereby causing high oil flow through the engine oil pump. Measure bearing bore in the upper end for wear, and compare with the drive gear supporting shaft diameter to determine that specifications (maximum 0.005-inch clearance) are maintained. Check the adapter all over for nicks or burs that could cause misalignment or oil leakage. See that the gear teeth and splines are in good condition with no abnormal indications of wear or pitting. Examine the cover bushing for scoring and tightness in position. Measure inside diameter for wear (maximum 0.004-inch clearance).

h. Inspect Accessory Drive Shafts. Check bearing location diameters closely for wear, and compare with bushing inside diameters in the rear section housing (maximum 0.006-inch clearance). It is important that specifications be rigidly maintained in this location. See that oil passages in the shafts are clear. Examine the gear teeth for wear or pitting of the hardened contact surfaces.

**ORDNANCE MAINTENANCE — 9-CYLINDER, RADIAL, GASOLINE ENGINE
(CONTINENTAL MODEL R975-C1)****31. REPAIR OF THE REAR SECTION.****a. Repair Crankcase Rear Section Housing.**

(1) **REPLACE ACCESSORY DRIVE SHAFT BUSHING.** The old bushing will be removed by pushing out with suitable sized arbor. It is not necessary to remove the pin from the bushing flange. Clean up any galling in the bushing bore of the housing with crocus cloth. Check size of the new bushing to determine that the specified fit (0.001 to 0.003 inch tight) will be provided. Heat the rear section in a flameless oven to 285° F, and cool the new bushing in dry ice. Aline slot in the bushing with the pin in the boss and press in place, making sure the bushing flange has seated against the housing before the housing cools. Install the diffuser chamber oil seals and spacers in place, and assemble the rear and diffuser sections together. Line ream the new bushing, using the fixture (41-F-2987-210) and the reamer (41-R-390) (fig. 123). Check fit of the shaft in the new bushing (0.0025 to 0.0045-inch clearance). Assemble the shaft and the three-way accessory drive adapter parts to the rear case, and check backlash between the bevel gears (0.004 to 0.012 inch). Spot face the bushing flange, if necessary, to provide the required amount of backlash. Separate the parts, and blow out all chips. Break all sharp edges, and clean the parts thoroughly.

(2) **REPLACE CRANKING MOTOR DRIVE GEAR BUSHING.** Bore out the old bushing until only a thin shell remains, and collapse the shell. Remove the remaining pieces of the bushing and the locking pin, using care to prevent damage to the housing. Clean up any galling or roughness in the bushing bore of the housing, and check the bore diameter to see that the specified amount of press fit (0.001 to 0.003 inch) will be provided. Cool the new bushing in dry ice, and heat the housing in a flameless oven to 285° F. Assemble the new bushing with the locking pin hole approximately ¼ inch away from the previous hole in the housing. Determine that the bushing flange is well seated before allowing the housing to cool. Using the hole in the bushing as a guide and a No. 31 (0.120-inch) drill, drill a new lock pin hole, and install the lock pin. Assemble the diffuser section to the rear section, and line ream the bushing, using the reamer (41-R-2324). Separate the parts, and blow out all chips. Break all sharp edges, and clean the parts thoroughly.

(3) **REPAIR HOUSING.** Stone to smooth over any nicks or burs on the machined parting flanges or bushing flanges, and polish with crocus cloth. Light scoring of the bushings can, in some cases, be corrected by polishing with crocus cloth. Ordinarily if the bushing is scored, it will be replaced.

R975-C1 ENGINE (CONTINENTAL)

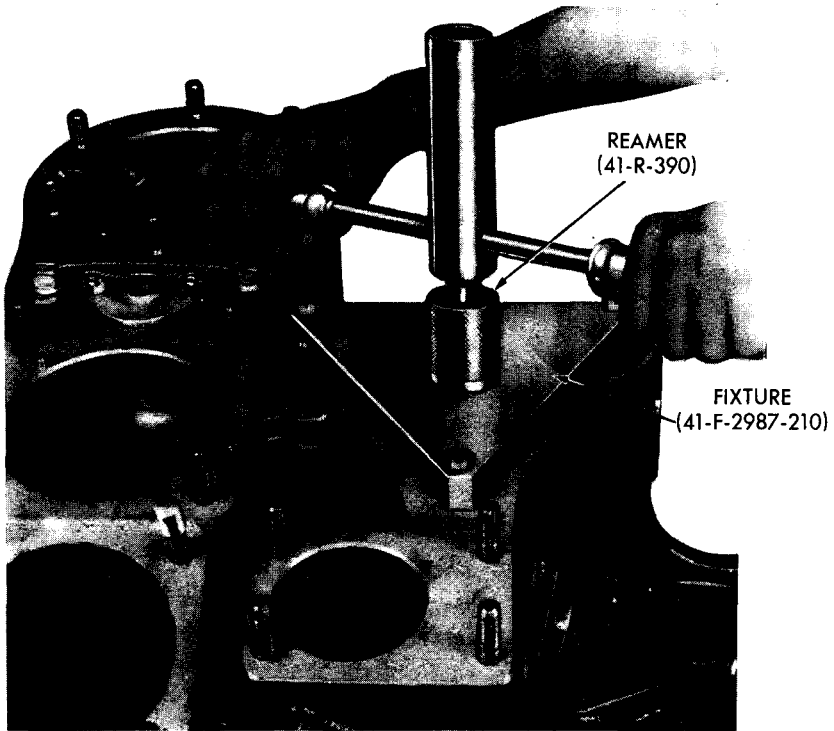

RA PD 309906

Figure 123 – Line Reaming Accessory Drive Shaft Bushing

b. Repair Tachometer Drive. Polish with crocus cloth to smooth over any nicks or burs on the gear teeth or machined flanges of the housing. Replace drive gears if the spirally grooved sleeves are worn (maximum 0.0035-inch clearance) or damaged.

c. Repair Main Oil Pump.

(1) **REPAIR OIL PUMP BODY.** Abnormal wear or damage to the pump housing can be corrected only by replacement with new parts. Deep scratches or excessive wear of the walls in the oil gear chambers increases the amount of oil slippage past the gears when the pump is operating. Light scratches will be smoothed over, but any further damage will be cause for replacement of the housing. The scavenge and pressure section of the pump body and the body spacer are not serviced separately. If any of these parts is damaged, replace the assembly. The gear separating plate may be smoothed up by rubbing lightly over a lapping block. Use light pressure, and lap carefully to remove only the minimum amount of material necessary to smooth up any ridges or nicks.

(2) **REPAIR GEARS.** Stone to smooth up any slight irregularities

**ORDNANCE MAINTENANCE — 9-CYLINDER, RADIAL, GASOLINE ENGINE
(CONTINENTAL MODEL R975-C1)**

such as nicks or burs, and polish with crocus cloth. It is particularly important that the tips of the teeth be smooth and free from sharp edges, since any slight imperfections will probably damage the pump housing during operation. This same condition is true of the flat ends of the gears.

(3) **REPAIR OIL PRESSURE RELIEF VALVE.** Damaged, worn, or defective oil pressure relief valve parts will be replaced with new parts from stock. No repair operations are authorized.

(4) **REPAIR OIL SUCTION STRAINER.** Parts of the oil suction strainer assembly will be replaced if defects or damages are noted.

d. Repair Three-way Accessory Drive.

(1) **REPLACE THREE-WAY ACCESSORY DRIVE GEAR BUSHING.** Bore out the old bushing until a thin shell remains, and collapse the shell. Remove the remaining pieces of the bushing, and clean up any galling of the housing with crocus cloth. Check the bore diameter and the new bushing diameter, to see that the specified amount of press fit (0.0015 to 0.0035 inch) will be provided. Cool the new bushing in dry ice, and heat the housing in hot oil or a flameless oven to 285°F. Aline oilholes and press the bushing in place, making sure the bushing flange is seated solidly before the housing is allowed to cool. Measure bearing diameter of the three-way accessory drive gear, and bore the new bushing to allow clearance of 0.001 to 0.003 inch. Oilholes in the bushing will be plugged with heavy grease before boring the bushing. The bushing bore must be in alinement with the vacuum pump adapter bore of the housing within 0.002 inch full indicator reading. Likewise, the bushing flange must be in alinement with the bore within 0.002-inch full indicator reading when the flange has been faced off to a distance of 0.654 to 0.656 inch from the three-way accessory drive housing mounting flange. Remove all grease and chips after machining, and break sharp edges.

(2) **REPAIR HOUSING.** Smooth over all nicks and burs on the machined flanges with stone, and polish with crocus cloth. Deep scratches or damage near the drilled pressure oilhole locations will be sufficient cause for replacement of the housing. No attempt will be made to correct difficulty of this nature since clearances would be increased, thereby increasing oil leakage under pressure and causing high oil flow.

(3) **REPLACE ADAPTER BUSHINGS.** Oilite bushings are used in both the fuel and vacuum pump drive adapters. These bushings are not to be reworked with a reamer or with an abrasive of any kind. The bearing structure is porous and there is the danger either of sealing the pores or embedding abrasive particles. To remove either bushing, machine out to a thin shell, collapse the shell, and remove the pieces.

R975-C1 ENGINE (CONTINENTAL)

Clean up the adapter bore with crocus cloth, and check for size to determine that specified press fit (fuel pump 0.0025 to 0.0045 inch, vacuum pump 0.0035 to 0.0045 inch) will be provided. To install the fuel pump adapter bushing, set the new bushing over a 0.7515-inch diameter shouldered sizing arbor, and press in place. Face off the bushing flange, if necessary, to obtain a distance of 1.714 to 1.720 inches to the adapter mounting flange. To install the vacuum pump adapter bushing, use a 0.6255-inch diameter shouldered sizing arbor to press in place. Face off the bushing flange, if necessary, to obtain a distance of 1.263 to 1.267 inches to the adapter mounting flange. Under no circumstances will a sealing compound of any kind be used when assembling an Oilite bushing. Burnishing broaches may be used to obtain the desired size after installation of a new bushing, but no reamers are to be used.

e. Repair Generator Drive Gear Support.

(1) **REPLACE GENERATOR DRIVE GEAR SUPPORT BUSHING.** This bushing is made of Oilite material, and the same replacement instructions outlined in the preceding subparagraph d (3) will apply here. For installation of the new bushing, use a 1.1260-inch diameter shouldered sizing arbor. Face off the bushing flange, if necessary, to obtain a distance of 1.523 to 1.527 inches to the support mounting flange.

(2) **REPLACE INTERMEDIATE GEAR BUSHING.** Replacement of the intermediate gear bushing requires the use of specialized equipment, and a more satisfactory repair job will be effected by replacement of the support assembly.

(3) **REPAIR SUPPORT CASTING.** Remove all nicks and burs from machined surfaces of the support casting. It is particularly important that all nicks or burs in the vicinity of the drilled oilhole be located and smoothed over. Do not remove any metal below the normal contour of the machined surfaces in these locations, or oil under pressure will be released directly into the scavenge system.

(4) **REPAIR GEARS.** Remove any nicks on the gear teeth with a fine stone. Polish bearing diameters on the gear shafts with crocus cloth wetted in gasoline.

(5) **DRILL DRIVE GEAR RETAINER NUT.** If a new nut is to be used at assembly of the engine, it will be necessary to drill a new locking pin hole at this time. Assemble the nut, shouldered side toward the gear, and tighten securely. Using a 0.078-inch diameter drill, drill the new hole to break through the gear shaft in the middle of the spline opposite from that which already has been drilled.

f. Repair Generator Idler Gear and Shaft.

(1) **REPLACE GEAR BUSHINGS.** The idler gear bushings may be removed by machining out until a thin shell remains, and col-

**ORDNANCE MAINTENANCE — 9-CYLINDER, RADIAL, GASOLINE ENGINE
(CONTINENTAL MODEL R975-C1)**

lapping the shell. Smooth the inside diameter of the gear with crocus cloth, and check for size together with the new bushing (0.0005 to 0.0035 inch tight). Press the new bushing in place, drill the lock pinhole (No. 43 drill, 0.089-inch), and install a new locking pin. Peen metal over after inserting the pin. Attach the gear and bushing assembly to the face plate of a lathe, and center on the pitch line by indicating over a 0.1800-inch diameter round pin placed between any two teeth. Bore the bushing to a size that will provide the specified clearance (0.001 to 0.003 inch). Face off each bushing flange to provide an over-all length of 1.654 to 1.658 inches across the two bushings. Chamfer each end of the bushing bore 45 degrees by 0.040 inch, and break all sharp edges.

(2) **REPAIR SHAFT.** Remove all nicks or burs on the shaft, particularly on the pilot locations at both sides of the annular oil groove. Be careful that no metal is removed below the normal contour of the piloting diameters, or the clearance between that and the rear section housing will permit escape of the engine oil under pressure.

g. Repair Tachometer and Three-way Accessory Drive Adapter.

(1) **REPLACE COVER BUSHING.** Remove the bushing by machining out to a thin shell and collapsing the shell. Clean up any galling in the cover bore with crocus cloth and check size to determine that the proper amount of press (0.0005 to 0.0025 inch) will be provided on the new bushing. Cool the new bushing in dry ice, and heat the cover in a hot oil bath to 285°F. Push the bushing in place, and make certain the flange is seated before the cover cools. Fasten the new assembly to the table of a boring machine, and center the spindle by indicating around the piloting diameter of the cover. Determine that the cover mounting flange is perpendicular to the axis of the spindle, and bore the bushing to allow clearance over the shaft of 0.0005 to 0.0025 inch. Face off the bushing flange parallel with the cover mounting flange and at a distance of 0.998 to 1.000 inch therefrom. Remove the assembly, break sharp edges, and thoroughly clean out.

(2) **REPAIR GEARS AND SHAFT.** Polish all bearing surfaces on the gears and shaft, and stone splines to smooth over any roughness or galling.

(3) **REPAIR ADAPTER.** Replace the adapter if it is badly scratched or damaged around the piloting surfaces on either side of the annular oil groove. Care will be exercised when removing slight nicks or damage in these surfaces that no metal is removed below the normal machined contour. Use a new adapter if the bearing bore for the

R975-C1 ENGINE (CONTINENTAL)

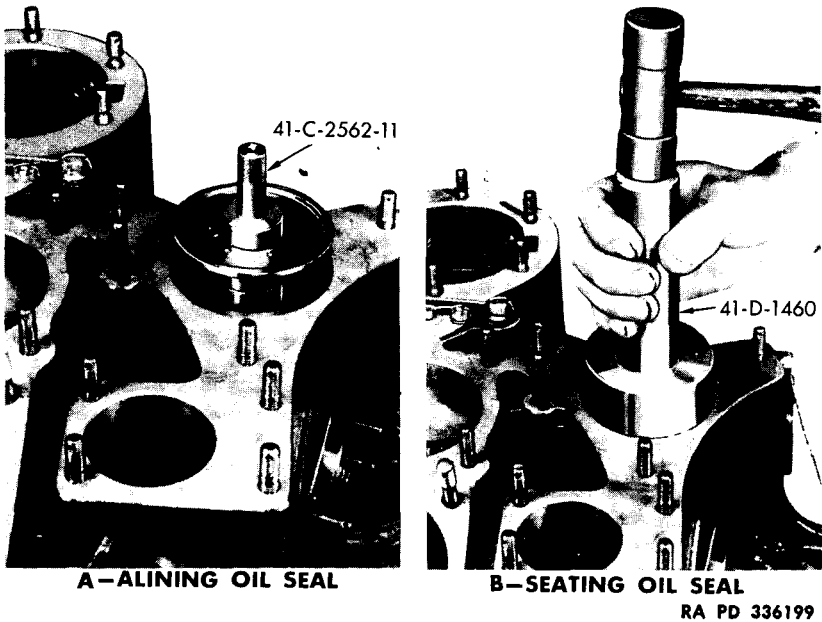

Figure 124 — Installing Magneto Drive Oil Seal

drive gear is worn beyond specified limits (maximum 0.005-inch clearance).

h. Repair Accessory Drive Shafts. Polish bearing surfaces as required, and stone splines to smooth over any roughness or galling.

32. ASSEMBLY OF THE REAR SECTION.

a. Install Accessory Drive Shafts (Magneto Drives). Check drive shafts to determine that the coupling retainer cotter pin and the rubber oil seal have been installed, and insert the shafts in the rear section. Set the oil seal installing cone (41-C-2562-11) on the end of the accessory drive shaft. Coat the leather on a new oil seal assembly with a liberal supply of engine oil and set over the cone (fig. 124). Align the attaching screw hole, and push the seal assembly in as far as possible by hand. Drive in place with a drift, and insert the attaching screw.

b. Assemble Tachometer and Three-way Drive Adapter. Assemble both gears in the adapter, and fasten together with the nut and cotter pin (fig. 125). Use a new gasket and assemble the cover. Place a new gasket over the adapter and down against the adapter mounting flange. Carefully insert the adapter assembly into the lower right side of the rear section, and secure with flat washers, nuts, and lock wire.

ORDNANCE MAINTENANCE — 9-CYLINDER, RADIAL, GASOLINE ENGINE
(CONTINENTAL MODEL R975-C1)

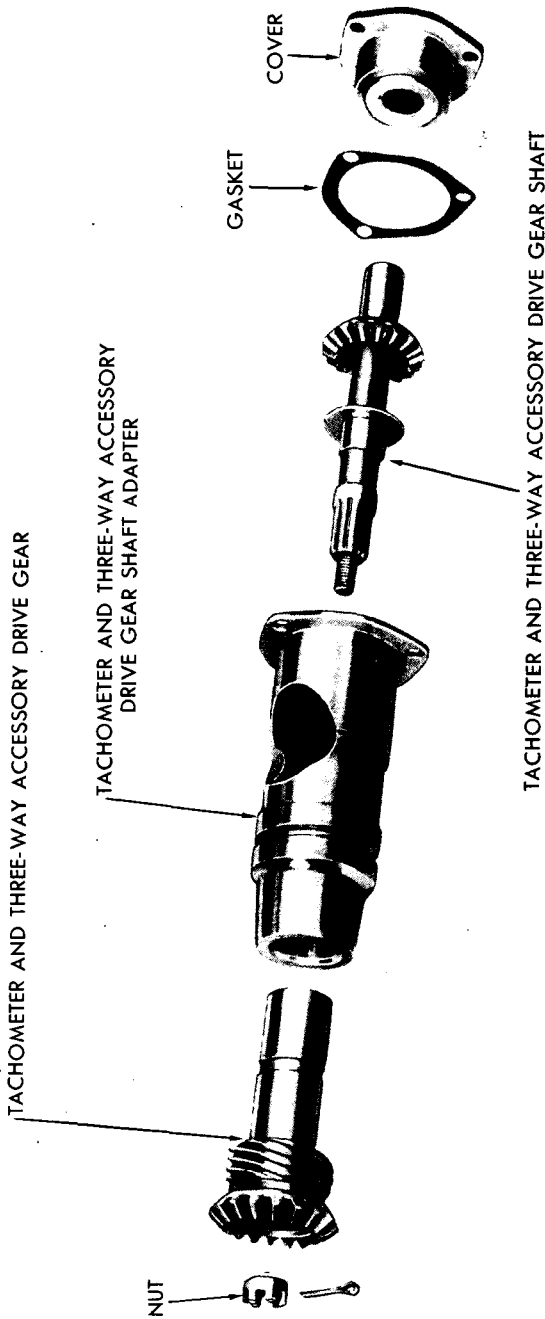

RA PD 309757

Figure 125 — Three-way Accessory Drive Adapter Disassembled

R975-C1 ENGINE (CONTINENTAL)

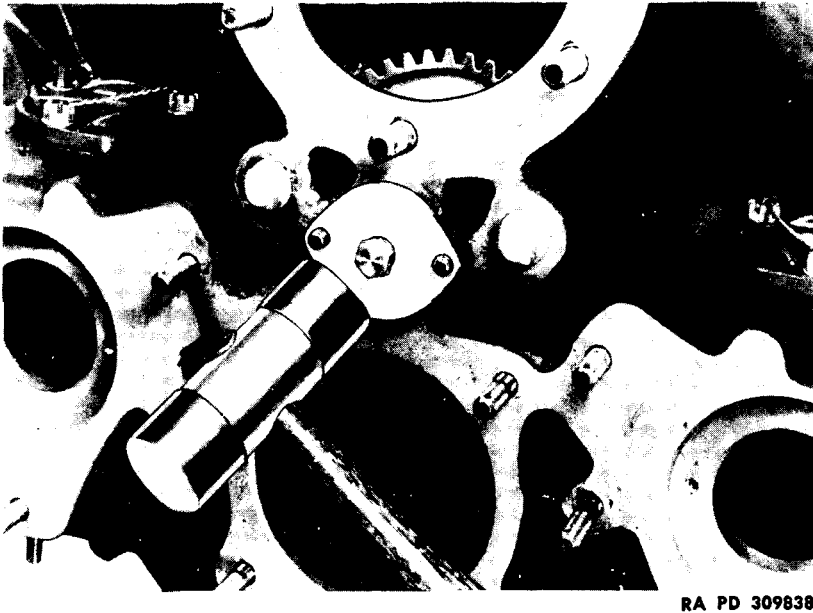

RA PD 309838

Figure 126 – Installing Generator Idler Gear Shaft

c. **Install Generator Idler Gear.** Place a new gasket over the generator idler gear shaft and down against the flange. Insert the idler gear through slots in the cranking motor mounting flange, and hold in position while the shaft is installed. Turn the shaft so that the small drilled pressure oilholes are facing up, aline holes in the flange with the two studs, and push in by hand as far as possible. Install and tighten a new shaft plug. Use a fiber hammer, and tap the shaft and plug assembly in until the flange seats solidly against the rear case (fig. 126). Fasten the shaft with flat washers, nuts and lock wire.

d. **Assemble Generator Drive Gear Support.** Submerge the support in a bath of engine oil for 15 minutes to saturate the Oilite bushing thoroughly. Remove the support from the oil bath, and assemble the generator drive gear (fig. 127). Assemble the nut (shouldered side toward the gear) on the end of the gear shaft, and tighten with the fingers. Insert the intermediate gear in the support, and secure with the thrust washer, flanged nut, and cotter pin. Block the gears from turning with a fiber wedge, and tighten the drive gear nut until the lock ring holes line up at tight position. Install the lock ring, making certain it is seated in the grooves all the way around the outside of the nut. Use a new gasket, and assemble the generator drive gear support assembly to the rear section. If a generator is

ORDNANCE MAINTENANCE — 9-CYLINDER, RADIAL, GASOLINE ENGINE
(CONTINENTAL MODEL R975-C1)

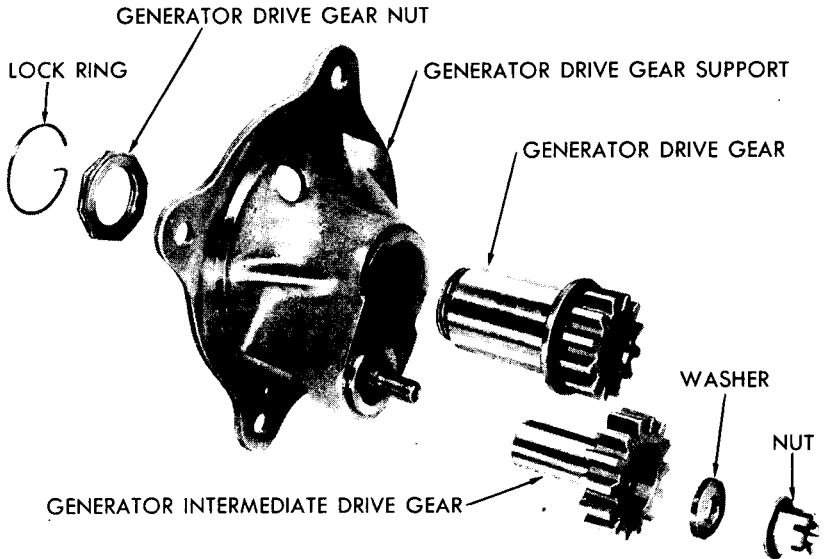

RA PD 309760

Figure 127 — Generator Drive Gear and Support Assembly Disassembled

not to be mounted directly on the engine when assembled in the vehicle, install another gasket and a cover plate, and secure with flat washers, nuts, and lock wire. Otherwise, place a nut on one of the studs to keep the support from falling until the generator is installed.

e. **Assemble A-C Fuel Pump and Adapter.** Submerge the fuel pump and drive shaft adapters in engine oil for 15 minutes to saturate the Oilite bushings thoroughly. Remove from the oil, and assemble the drive shaft (fig. 128). Set the assembly in place in the fuel pump drive adapter, and secure with screws and lock wire. Place a new gasket on the fuel pump mounting flange. Rotate the drive shaft so that the fuel pump reciprocating arm will contact the lower part of the cam, and assemble the fuel pump. Secure with flat washers, nuts, and lock wire. The adapter and pump assembly will not be installed on the three-way accessory drive until final assembly of the engine.

f. **Assemble Three-way Accessory Drive Housing.** Submerge the vacuum pump adapter in an oil bath for 15 minutes to saturate the Oilite bushing thoroughly. Assemble the three-way accessory drive gear and the vacuum and fuel pump drive shaft assembly in the housing (fig. 129). Use a new gasket, and assemble the vacuum pump adapter. Use another new gasket, and assemble the vacuum

R975-C1 ENGINE (CONTINENTAL)

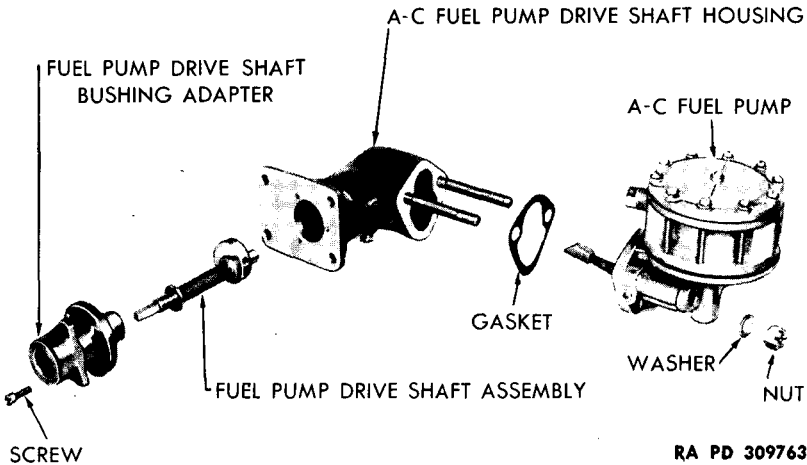

RA PD 309763

Figure 128 — A-C Fuel Pump and Adapter Assembly Disassembled

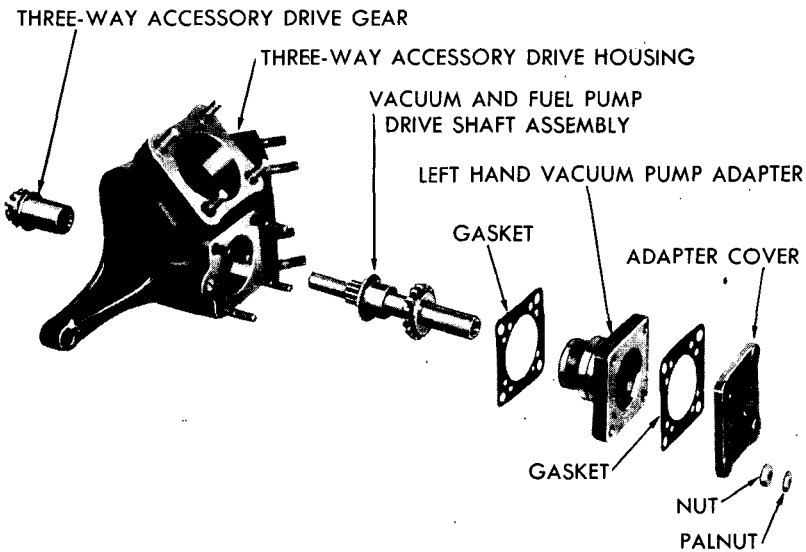

RA PD 309754

Figure 129 — Three-way Accessory Drive Housing and Fuel Pump Drive Shaft Disassembled

pump replacement cover. Secure with flat washers, nuts, and palnuts. The housing will be installed on the engine at final assembly.

g. Assemble Main Oil Pump Gears and Housing. Submerge the scavenge pump body in engine oil for 15 minutes to saturate the governor drive Oilite bushing thoroughly. Set the drive and driven

ORDNANCE MAINTENANCE — 9-CYLINDER, RADIAL, GASOLINE ENGINE
(CONTINENTAL MODEL R975-C1)

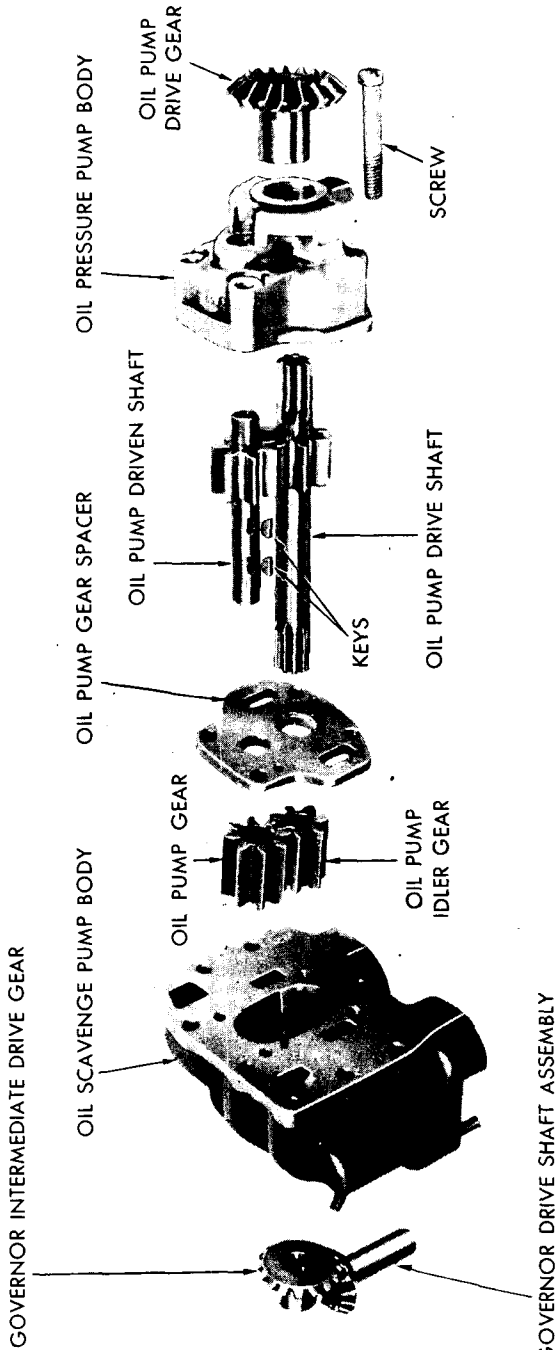

RA PD 309759

Figure 130 — Main Oil Pump Disassembled

GOVERNOR DRIVE SHAFT ASSEMBLY

R975-C1 ENGINE (CONTINENTAL)

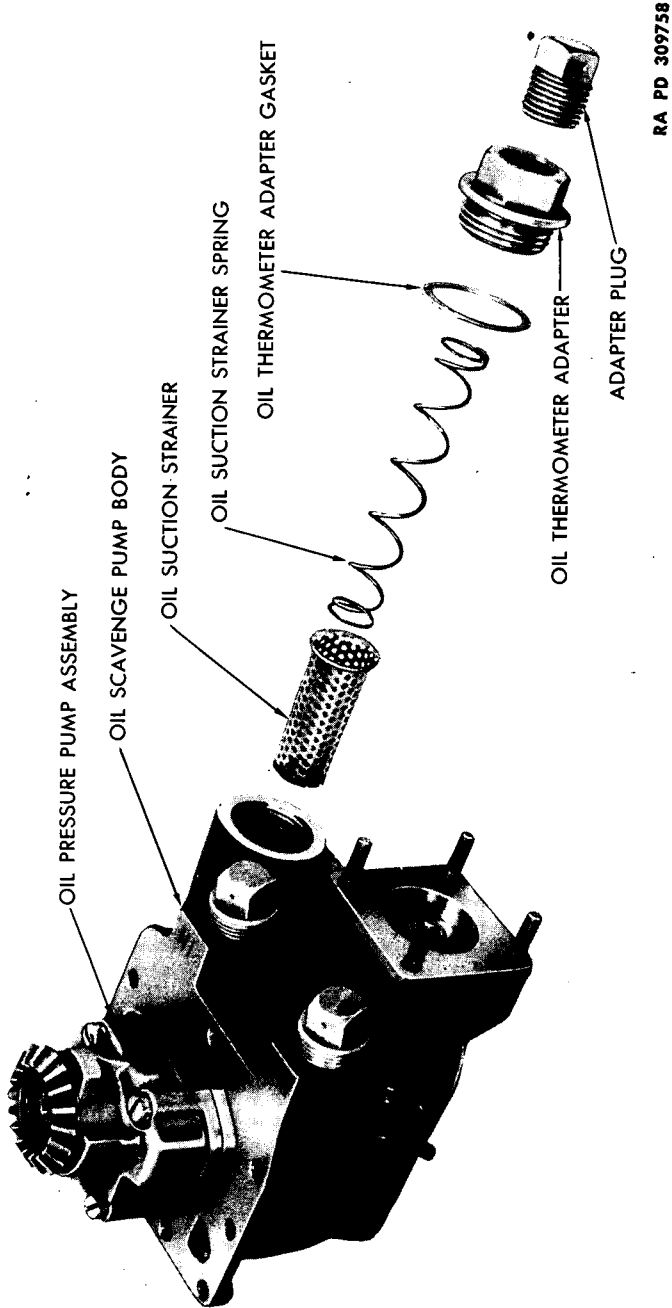

Figure 131 — Oil Pump Suction Strainer Disassembled

ORDNANCE MAINTENANCE — 9-CYLINDER, RADIAL, GASOLINE ENGINE
(CONTINENTAL MODEL R975-C1)

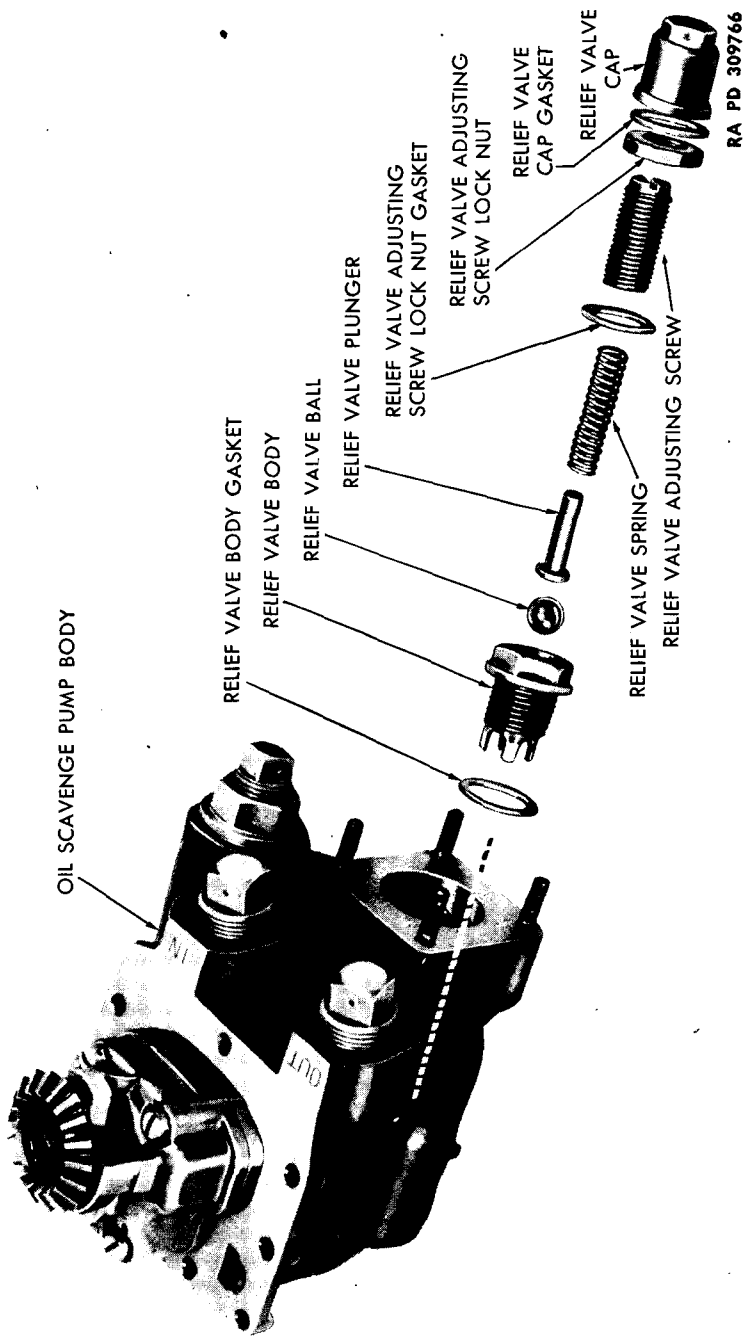

Figure 132 — Oil Pressure Relief Valve Disassembled

R975-C1 ENGINE (CONTINENTAL)

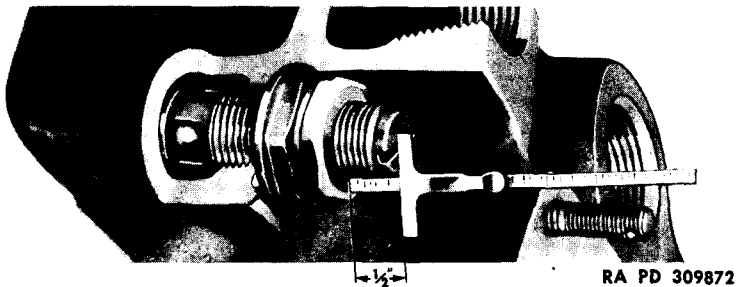

Figure 133 – Oil Pressure Relief Valve Setting

gear shafts in position in the pressure section of the oil pump body, and assemble the spacer (fig. 130). Insert keys in the driven shaft, and assemble the scavenge gears. Remove the scavenge pump body from the oil bath, and place the governor drive gears in position. Assemble the pressure section to the scavenge section, and secure with the four screws and lock wire. Use a new gasket, and assemble the oil pump body cover. Secure with flat washers, nuts, and palnuts.

h. Assemble Oil Pump Strainer. Insert the strainer and spring in the body of the pump (fig. 131). Place a new gasket on the oil thermometer adapter, and screw the adapter into the pump body. Install a plug in the adapter if the oil thermometer is not ready for installation at this time.

i. Assemble Oil Pressure Relief Valve. Using a new gasket, assemble and tighten the relief valve body (fig. 132). It is very important that the relief valve body be the first part of the valve assembly to be installed in the pump. Roll ball into the relief valve body, and insert the plunger and spring. Engage the adjusting screw threads in the relief valve body for about three turns. Use a new gasket, and assemble the lock nut to the adjusting screw. Turn the lock nut down to where it rests finger-tight against the relief valve body. Set the adjusting screw so that the distance measured from the outer face of the lock nut to the end of the adjusting screw is $\frac{1}{2}$ inch (fig. 133). Hold the adjusting screw in this position while tightening the lock nut snug. Use a new gasket, and assemble the cap, but do not lock wire at this time, as it will be necessary to readjust the oil pressure after the engine has been assembled and put in operation. The oil pump will be installed on the engine at final assembly.

j. Assemble Tachometer Drive. Slide the tachometer drive gear, shaft, and bearings assembly into the housing (fig. 134). Use a new gasket, and assemble the housing cover. Align the small cut-out section of the cover with the stud hole between the two

ORDNANCE MAINTENANCE — 9-CYLINDER, RADIAL, GASOLINE ENGINE
(CONTINENTAL MODEL R975-C1)

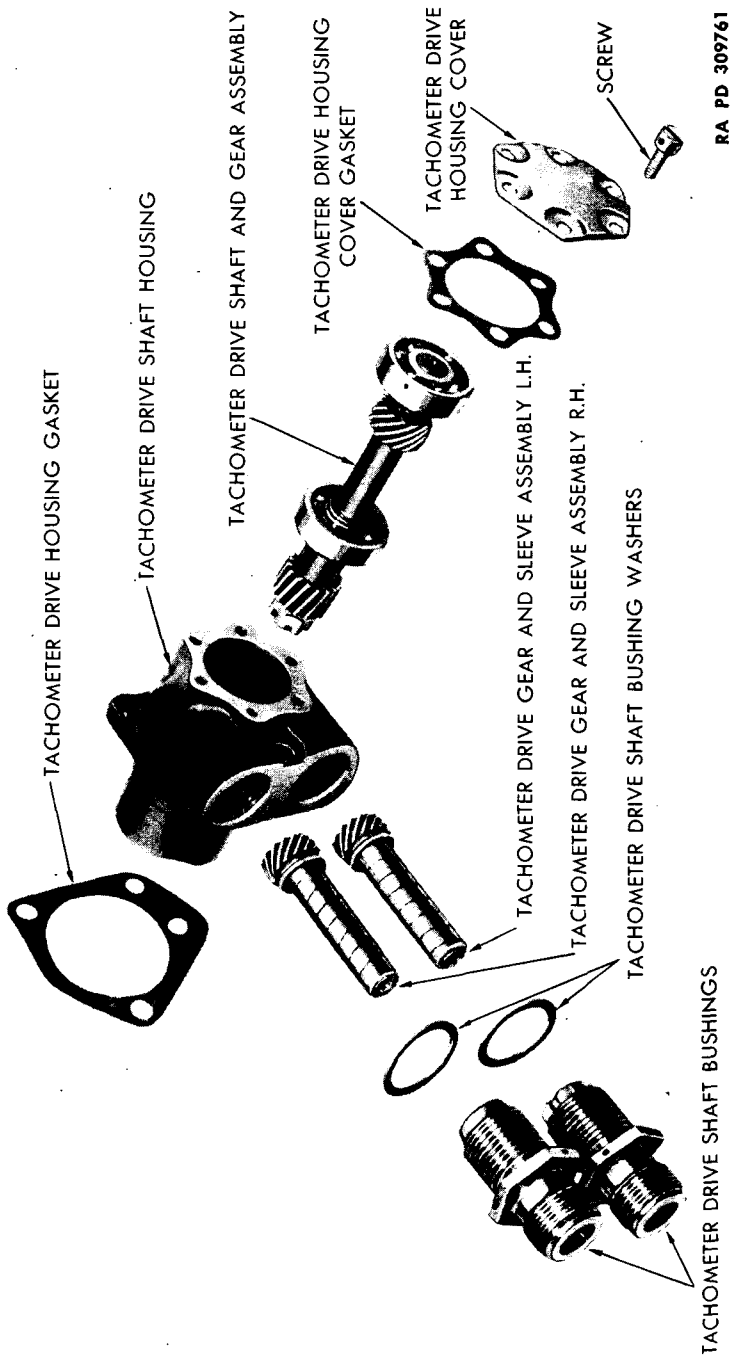

Figure 134 — Tachometer Drive Disassembled

8975-C1 ENGINE (CONTINENTAL)

tachometer drives, and install the cover retaining screws. Tighten the screws, and secure with lock wire. Refer to figure 134, and note that spiral grooves machined in the gear and sleeve assemblies turn in different directions. When the engine is assembled and operating, the upper tachometer drive turns in a counterclockwise direction. Select the gear and sleeve machined so that oil will run in toward the gear end when rotated in a counterclockwise direction, and insert in one of the drive shaft bushings. Use a new washer, and assemble this unit to the housing. Insert the other gear and sleeve assembly in the remaining bushing, select a new washer, and assemble parts to the housing. It is important that the tachometer drive gear and sleeve assemblies be installed in their correct positions, or the spiral grooves will tend to force oil out of the housing instead of keeping it in. **CAUTION:** *Gear and sleeve marked in disassembly must be installed in position as marked so that oil will flow in proper direction. If a new gear and sleeve is installed, oil grooves must be cut in same direction as on the gear and sleeve being replaced.* The tachometer drive assembly will be installed on the engine at final assembly.

Section VIII

ASSEMBLY OF THE ENGINE

33. ASSEMBLY OF ENGINE COMPONENTS.

a. **Install Cranking Motor Shaft Oil Seal.** Place a new seal over the retainer and insert, flanged end first, in the cranking motor shaft hole of the rear section (fig. 135). Drive in place with the drift (41-D-1546-55). See that the spacer (fish plate) is in position.

b. **Install Accessory Drive Shaft Oil Seals.** See that the retainer is in place, flanged end up, on each of the accessory drive shaft bushings protruding through the rear of the diffuser section, and assemble the oil seals. Check spacers (fish plates) next to each of the bushings to see that they are tight.

c. **Assemble Diffuser Section to Rear Section.** Apply a thin coating of gasket material to the parting flange of the rear section, and set the diffuser section in place. Tap lightly around the edges of the diffuser section until it is well seated all the way around. Place a new rubber oil seal around the diffuser section oil tube, and push down into the diffuser section flange. Fasten the diffuser section with three flat washers, nuts, and cotter pins (fig. 50).

d. **Assemble Accessory Drive Gears.** Place Woodruff keys in the shafts, and assemble the accessory drive gears. Block the gears

**ORDNANCE MAINTENANCE — 9-CYLINDER, RADIAL, GASOLINE ENGINE
(CONTINENTAL MODEL R975-C1)**

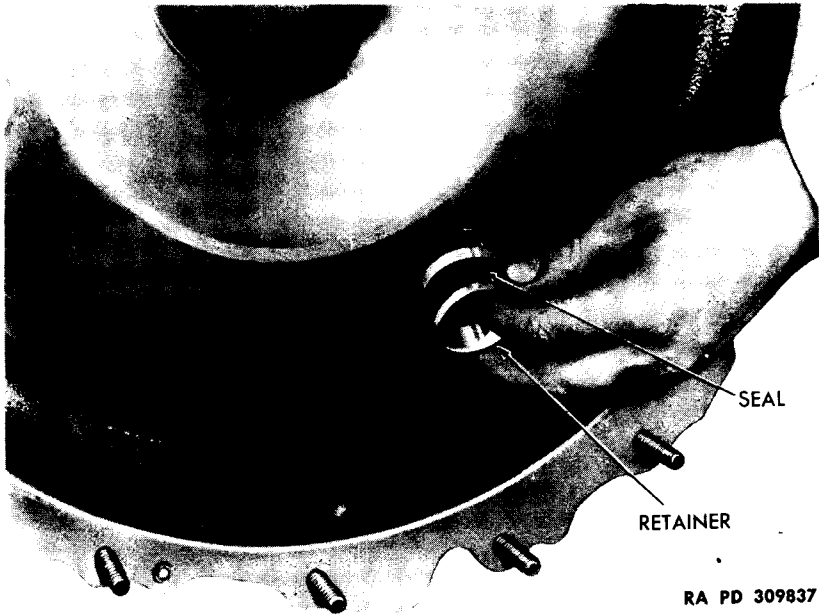

RA PD 309837

Figure 135 — Installing Cranking Motor Shaft Oil Seal and Retainer

from turning with a fiber wedge, assemble the nuts, and tighten securely (fig. 136). Lock the nuts with cotter pins.

e. **Assemble Cranking Motor Drive Gear and Cranking Motor Shaft.** Insert the cam pinion and cranking motor shaft bolt through the cranking motor drive gear, and assemble the washer, spring, and spring retainer (fig. 137). Secure the spring and retainer by inserting the retainer pin. Set the parts just assembled in place through the diffuser section. Insert the cranking motor shaft through from the rear section, and place the nut on the end of the bolt. Draw the nut up snug, but not tight. Do not insert cotter pin at this time.

f. **Assemble Main Section to Diffuser and Rear Sections.** Check to see that gears in the diffuser section turn free with no binding. Apply a thin coating of gasket material to the front flange of the diffuser section. Install the lifting eye (41-E-615) on the front of the crankshaft and attach to a chain hoist. Carefully lower the main section in place on the diffuser and rear sections assembly. Attach with flat washers, nuts, and lock wire on all studs except those over which the ignition manifold clips are to be assembled.

g. **Assemble Front Crankshaft Gear.** Set the key in place, and hold while assembling the front crankshaft gear. Do not allow the key to fall down into the main section.

R975-C1 ENGINE (CONTINENTAL)

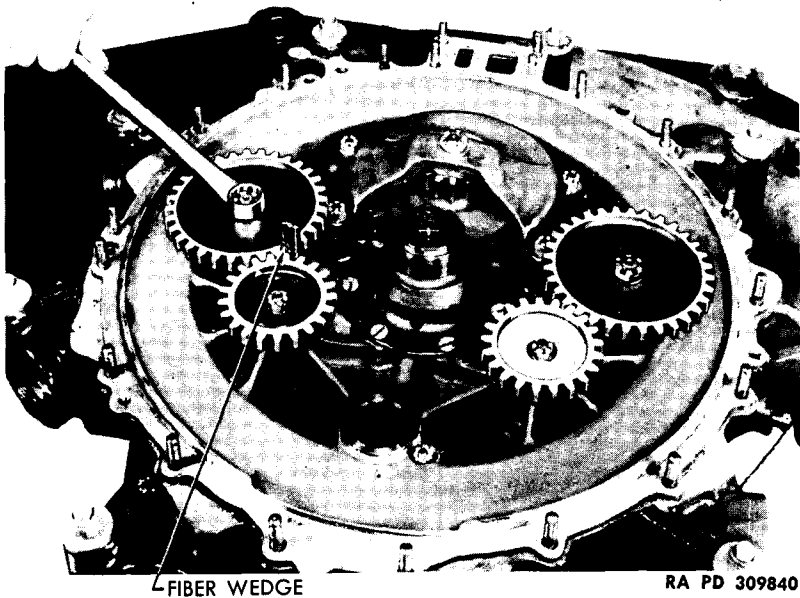

Figure 136 – Tightening Accessory Drive Gear Nut

h. Install Front Main Bearing Support. Apply joint and thread compound type “A” to the parting flange of the front main bearing support, and slip the section into position over the front end of the crankshaft (fig. 138). Aline stud holes, and tap the support in against the crankcase.

i. Assemble Crankcase Front Section. Apply joint and thread compound, type “A” to the front section parting flange, and assemble the front section (fig. 139). Make sure the crankshaft front gear and the scavenge pump gear are in mesh before attempting to push the front section all the way in against the front main bearing support. Assemble flat washers and nuts on the studs. Tighten the nuts to 175 to 200 inch-pounds, and secure with lock wire.

j. Install Thrust Bearing and Front Cover. Lightly coat the thrust bearing location on the crankshaft with graphite grease, and assemble the thrust bearing, numbered side toward the front. Use a brass drift, if necessary, and tap lightly on the inner race to seat the bearing solidly in the front section. Assemble the oil slinger, dished side up, over the end of the crankshaft and down on the bearing. Assemble the shim and the front cover. Hold the cover down firmly, and check the amount of clearance for draw by inserting feeler gage stock between the shim and cover. If the clearance is not within the

ORDNANCE MAINTENANCE — 9-CYLINDER, RADIAL, GASOLINE ENGINE
(CONTINENTAL MODEL R975-C1)

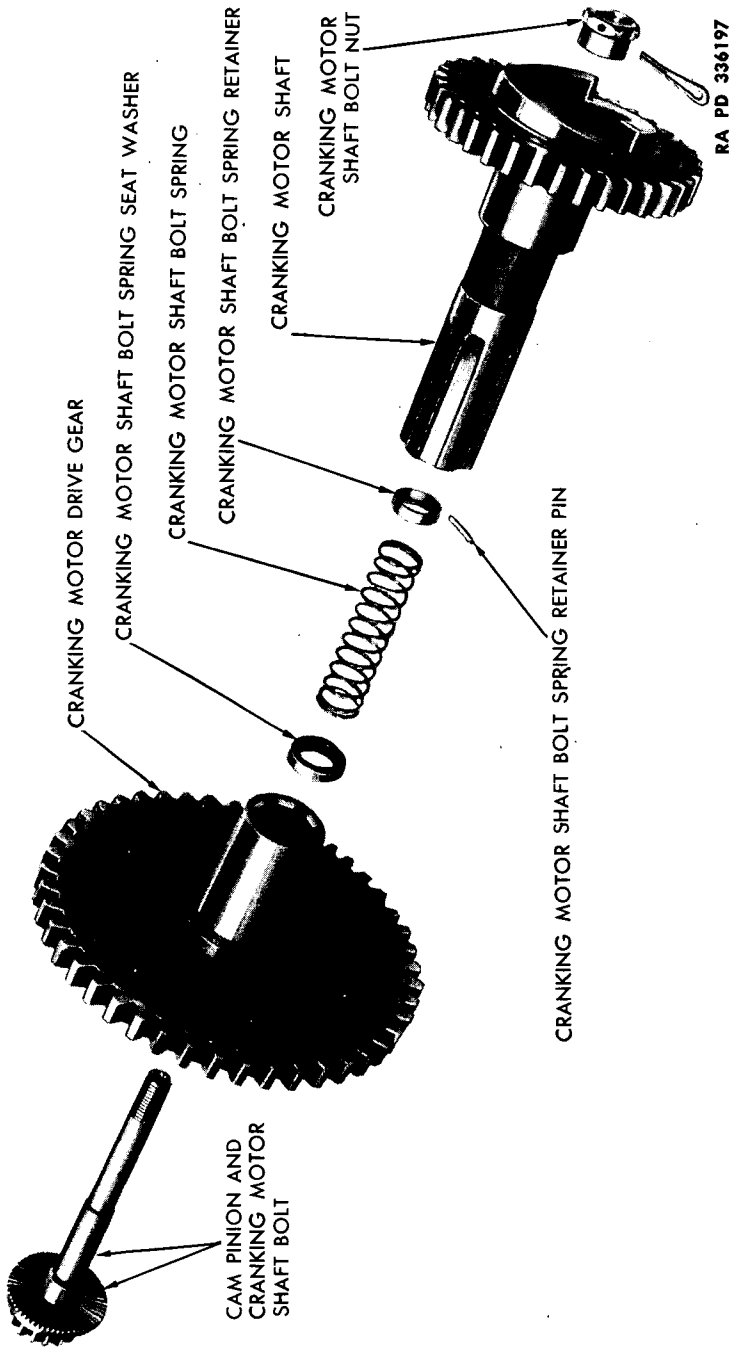
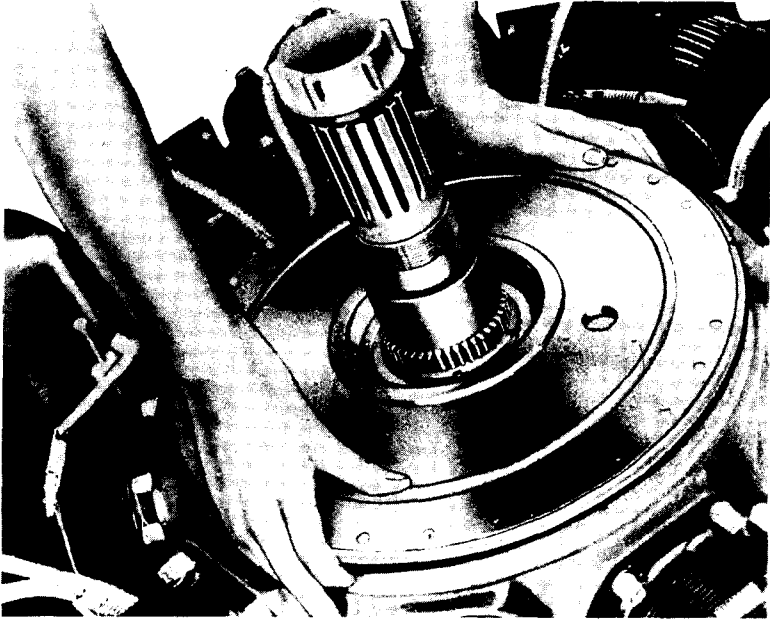

Figure 137 — Cam Drive and Cranking Motor Drive Disassembled

R975-C1 ENGINE (CONTINENTAL)



RA PD 309854

Figure 138 — Installing Front Main Bearing Support

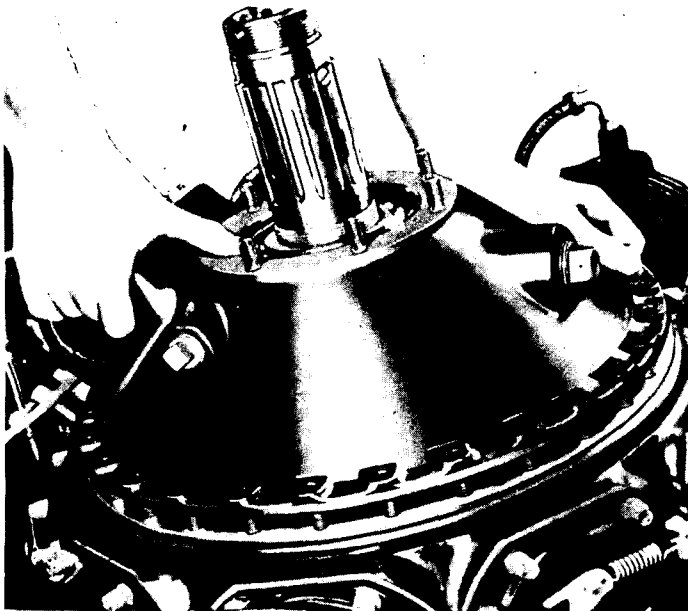

RA PD 309873

Figure 139 — Installing Crankcase Front Section

**ORDNANCE MAINTENANCE — 9-CYLINDER, RADIAL, GASOLINE ENGINE
(CONTINENTAL MODEL R975-C1)**

limits of 0.005 to 0.007 inch, correct it by removing the required number of laminations from the shim or by using a new shim. Laminations are each 0.002 inch thick. If the clearance is too great, a thicker shim will be required. When the correct amount of clearance for draw has been obtained, place flat washers over the studs and assemble the nuts. Tighten the nuts to 225 to 250 inch-pounds torque, and secure with lock wire. Install the thrust nut and oil seal ring assembly on the crankshaft. Use the oil seal ring inserting clamp to compress the rings while tightening the nuts. The thrust nut will be fully tightened after the cylinders have been assembled to the crankcase.

k. Install Ignition Wiring Harness. Install the ignition wiring harness on the engine, placing the four manifold clips over the rear to main section studs. Assemble flat washers and nuts on the studs. Tighten the nuts, and secure with lock wire. Use care to avoid striking distributor blocks against the engine while installing the harness.

l. Install Oil Sump. Use a new gasket, and assemble the adapter to the oil sump, securing with the two cap screws. Place a new gasket over the adapter studs on the lower front of the crankcase main section, and assemble the oil sump and adapter assembly. Place a new washer between the sump and the crankcase at the rear connection, insert the adapter and oil passage connector in place, and screw in the strainer housing, using wrench (41-W-906-12). Tighten and secure the strainer housing with lock wire. Install the strainer, spring, washer, and sump plug. Tighten the sump plug to 600 to 700 inch-pounds, and secure with lock wire. Nuts will not be installed on the adapter studs until after the cylinder air deflector support is assembled.

m. Assemble Pistons and Piston Pins. Space gaps on the piston rings of No. 1 piston, and cover with a liberal supply of engine oil. Hold the piston in place, numbered side toward front of the engine, on the master rod, and insert the piston pin (fig. 140). If the pin is tight in the piston, support the weight of the piston away from the rod, and use the fiber drift (41-D-1541-75) to drive in. Install new piston pin retainers in the grooves at each end, and be absolutely sure they are seated completely all the way around. See that the side of the piston bearing the number is toward the front of the engine. Double check to make certain the two piston pin retainers are in place in the grooves machined in the piston pin bore.

n. Assemble Cylinders. Install the timing fixture (41-F-2997-84) on the crankshaft, and turn the No. 1 piston up to top center. Coat the cylinder bore with engine oil, and place a new rubber oil seal ring over the barrel and down against the mounting flange. Compress the piston rings, using clamp (41-C-2550-80), and slip the

R975-C1 ENGINE (CONTINENTAL)

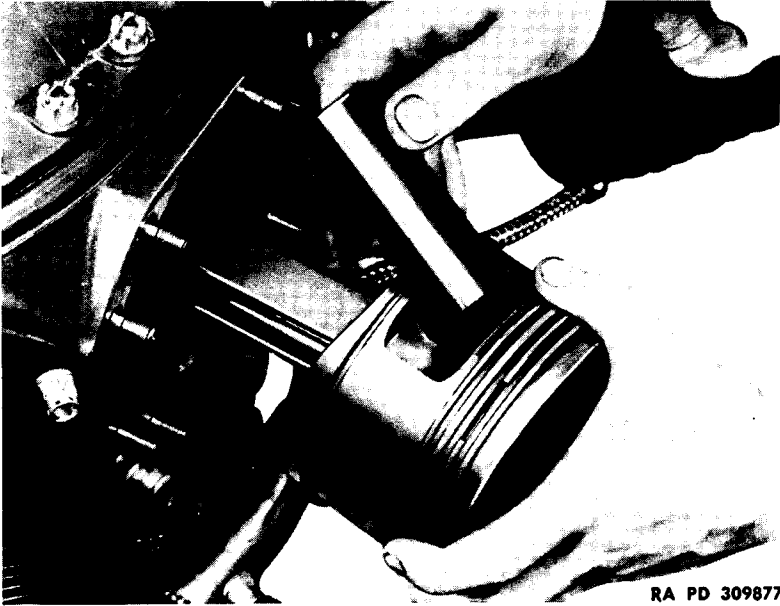
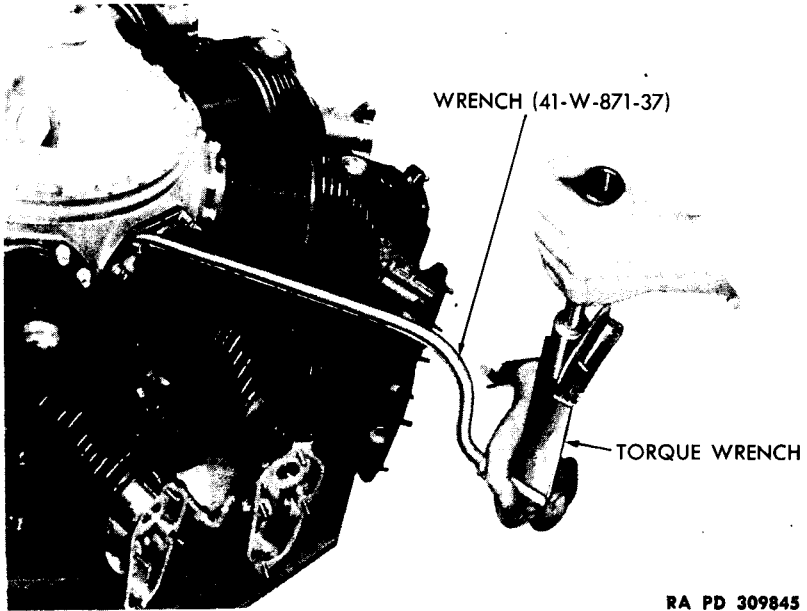

Figure 140 — Installing Piston Pin



Figure 141 — Installing Cylinder

**ORDNANCE MAINTENANCE — 9-CYLINDER, RADIAL, GASOLINE ENGINE
(CONTINENTAL MODEL R975-C1)**



RA PD 309845

Figure 142 — Tightening Cylinder Hold-down Nuts

cylinder over the piston and hold-down studs (fig. 141). Use thread lubricant on the studs, install the hold-down nuts, and tighten finger-tight. Tighten two nuts opposite each other to 250 inch-pounds, using the wrench (41-W-871-37) together with a torque-indicating handle (fig. 142). Proceed in the same general manner until all nuts are tightened. Finally, tighten all of the nuts consecutively around the cylinder, using specified torque of 425 to 450 inch-pounds. Care should be taken that the wrench does not bind on any part of the engine. See that the torque-indicating handle is in its proper position when reading tightening torque. Secure all nuts on the cylinder flange with lock wire before proceeding with installation of the next cylinder. Proceed with installation of the remaining pistons and cylinders. Set the crankshaft to place each piston on top center before installing the cylinder assembly. **CAUTION:** *The importance of using the correct procedure and tightening cylinder hold-down nuts to the specified torque cannot be too strongly emphasized. Nuts are not to be tightened beyond specified limits, as in so doing, the studs may be stretched or broken. Likewise, they must not be allowed to remain looser than required, since this alone can cause early fatigue failures of the studs.*

R975-C1 ENGINE (CONTINENTAL)

o. Install Front Oil Sump Tubes. Using a new gasket under the flange, install the internal tube to the oil sump. Place a new hose connection and two clamps on the external tube, and slide onto the oil sump hose connection nipple in the crankcase front section. Place a new gasket between the internal and external tube flanges, and install the two retaining cap screws. Secure the cap screws with lock wire and tighten the hose clamp screws.

p. Install Intercylinder Air Deflectors. Assemble the air deflector support over the two oil sump adapter studs between cylinders Nos. 5 and 6, and secure with flat washers, nuts, and lock wire. Set deflectors in place, hook clamps around the cylinders, connect springs, and snap clamps in place. Use the tie rod assembly to fasten the deflector between Nos. 5 and 6 cylinders. Fasten clamps with cotter pins. Draw ignition wire conduits through holes in the deflectors, and fasten the disks and grommets with flat washers and screws. The screws are self-locking.

q. Install Intake Pipes. Slide packing nuts and new rubber packing on the intake pipes, and assemble to the engine. Place a new gasket under each intake pipe flange, and install two of the cap screws. Draw cap screws up snug, but not tight. Slide packing down into the crankcase outlets, and tighten the packing nuts in place, using the lug wrench (41-W-1537). It is possible to swedge the pipes by excessive tightening of the packing nuts.

r. Install Push Rod Housings. Rotate the overhaul stand so that the splined, or front, end of the crankshaft is pointing down. Assemble valve tappet springs and ball sockets in the tappets. Place clamps and new hose connections on each end of the push rod housings. Set the housings on the engine, and slide the hose in place. Hold the housings against the rocker box end, and tighten clamps on the crankcase end, using the wrench (41-W-1986).

s. Install Cylinder Head Air Deflectors. Assemble air deflectors, and secure with a cap screw through the bracket and into the cylinder intake flange. Tighten all three cap screws in each intake flange, and secure with lock wire.

t. Install Push Rods and Rocker Arms. Insert the push rods, and assemble the rocker arms and rocker hub bolts in the rocker boxes (fig. 143). Insert bolts from the cylinder side of the boxes. Assemble the washers and hub bolt nuts. Tighten the nuts, using a socket wrench together with a torque-indicating handle (fig. 144). The specified torque setting is 250 to 300 inch-pounds.

u. Install Rear Spark Plugs. Use new gasket and install all rear plugs. Tighten to a torque setting of 475-inch pounds, using the socket wrench (41-W-3328). Attach wiring harness elbow coupling

**ORDNANCE MAINTENANCE — 9-CYLINDER, RADIAL, GASOLINE ENGINE
(CONTINENTAL MODEL R975-C1)**

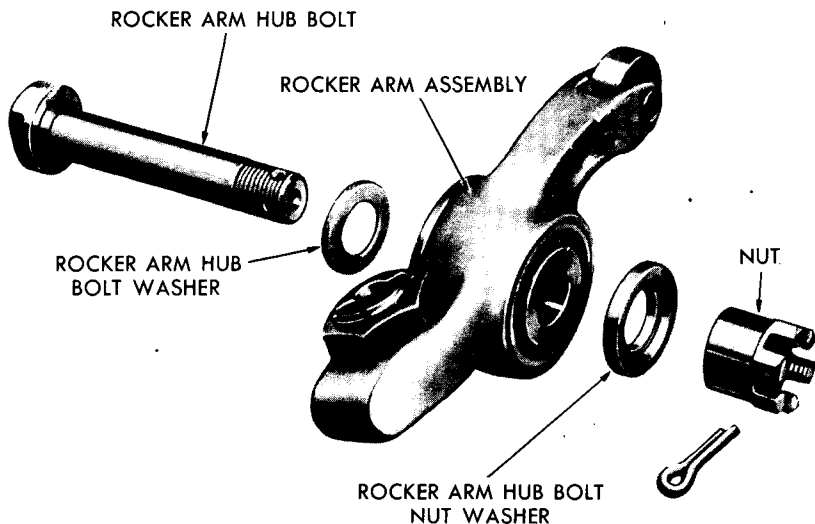

RA PD 309793

Figure 143 — Rocker Arm Assembly Disassembled

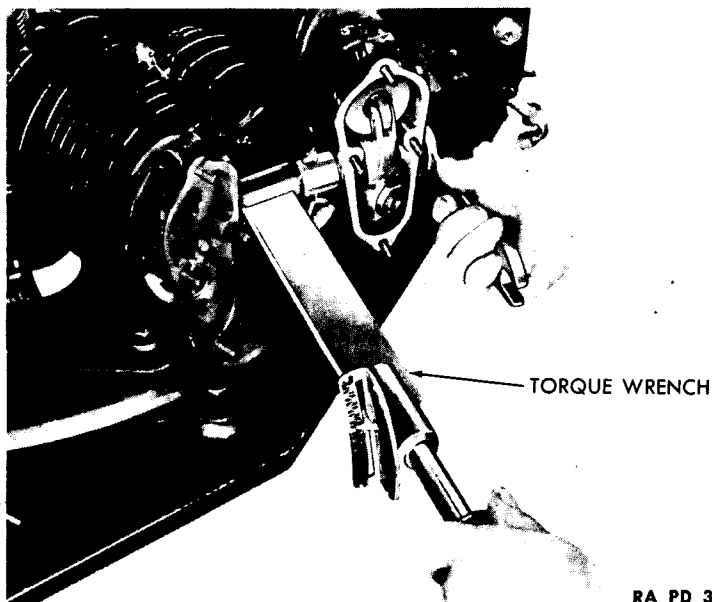

RA PD 309846

Figure 144 — Tightening Rocker Arm Hub Bolt and Nut

R975-C1 ENGINE (CONTINENTAL)

nuts, and tighten securely. Care will be exercised that the nuts are not tightened excessively, but only a sufficient amount for a snug fit. Otherwise, the terminal nut or the spark plug may be damaged.

v. **Install Atmospheric Breather.** Use new hose, and assemble the atmospheric breather to the crankcase main and rear sections (fig. 25). Fasten the supporting bracket to the cylinder head rocker box with a cap screw. Tighten the hose clamps, using the wrench (41-W-1986).

w. **Install Main Oil Pump.** Use new gasket, and assemble the main oil pump to the lower left side of the rear section. Secure with flat washers, castellated nuts, and lock wire or cotter pins as required. Tighten nuts on the front and right sides with the lug wrench (41-W-3418). Use the box end wrench (41-W-1577-500) to tighten the remaining nuts.

x. **Install Tachometer Drive.** Use a new gasket, and assemble the tachometer drive to the right side of the rear section. Fasten the drive with flat washers, nuts, and lock wire.

34. ASSEMBLY OF EXTERNAL PARTS.

a. **Install Priming System.** Attach the priming distributor to the No. 1 intake pipe, assemble the tubes in their locations, and attach to the intake pipes with the clamps. Screw the union nuts on their fittings on the upper seven intake pipes.

b. Establish Timing Disk Pointer Setting.

(1) **INSTALL TIMING DISK POINTER.** Install the timing fixture (41-F-2997-84) over the splined end of the crankshaft, and attach the pointer to the front section (fig. 145). Insert the top dead center indicator (41-I-73-110) in the front spark plug hole of No. 1 cylinder, and tighten until snug.

(2) **SET TOP DEAD CENTER INDICATOR.** Turn the crankshaft until the top dead center or zero point on the timing disk is opposite from No. 1 cylinder. This will place the No. 1 piston approximately at the bottom of its stroke. Note reading of the top dead center dial indicator. Continue turning the crankshaft in the proper direction of rotation (counterclockwise when viewed from the front) until the needle on the dial indicator has started to move and made approximately one-half revolution. Set zero on the face of the dial indicator to register with the needle pointer, and note reading on the timing disk as indicated by the pointer.

(3) **LOCATE TOP DEAD CENTER.** Continue turning the crankshaft until the dial indicator needle stops and then reverses direction, noting how many revolutions it turned before stopping. Continue turning slowly until the needle has turned the same number of revo-

ORDNANCE MAINTENANCE — 9-CYLINDER, RADIAL, GASOLINE ENGINE
(CONTINENTAL MODEL R975-C1)

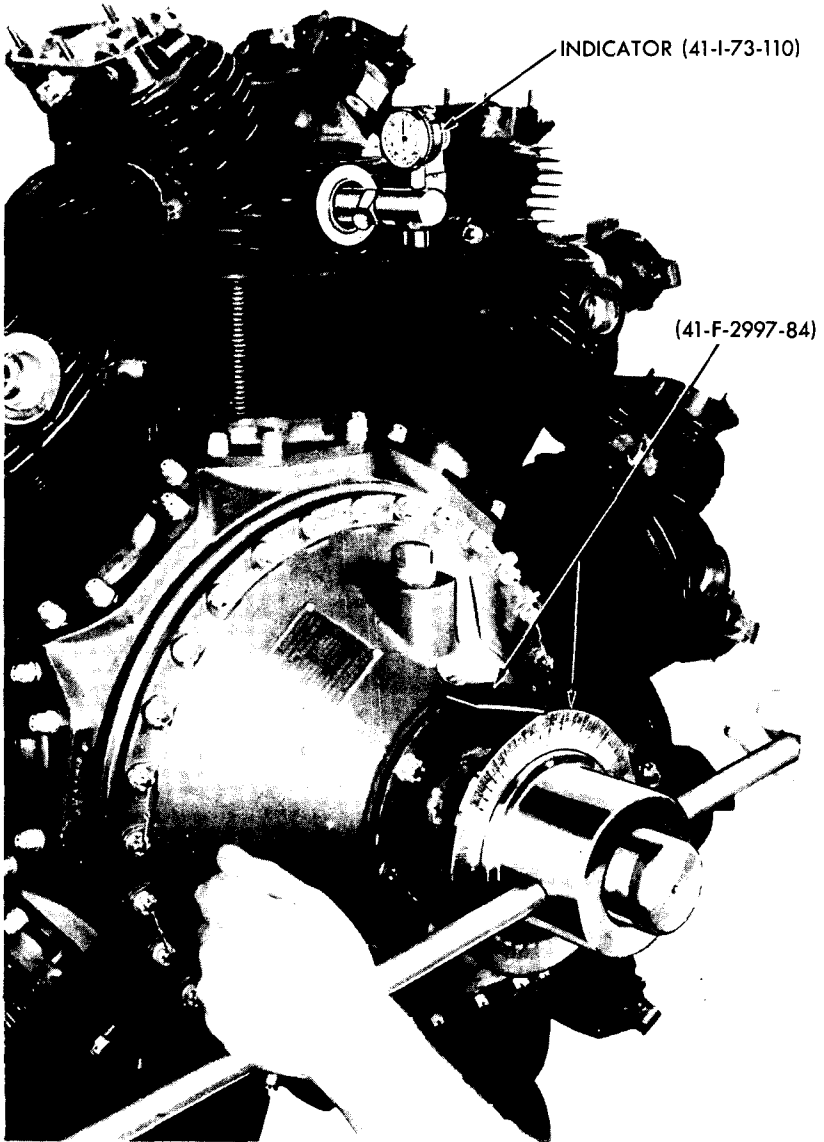

RA PD 309847

Figure 145 — Locating Top Center of Master Rod Piston

R975-C1 ENGINE (CONTINENTAL)

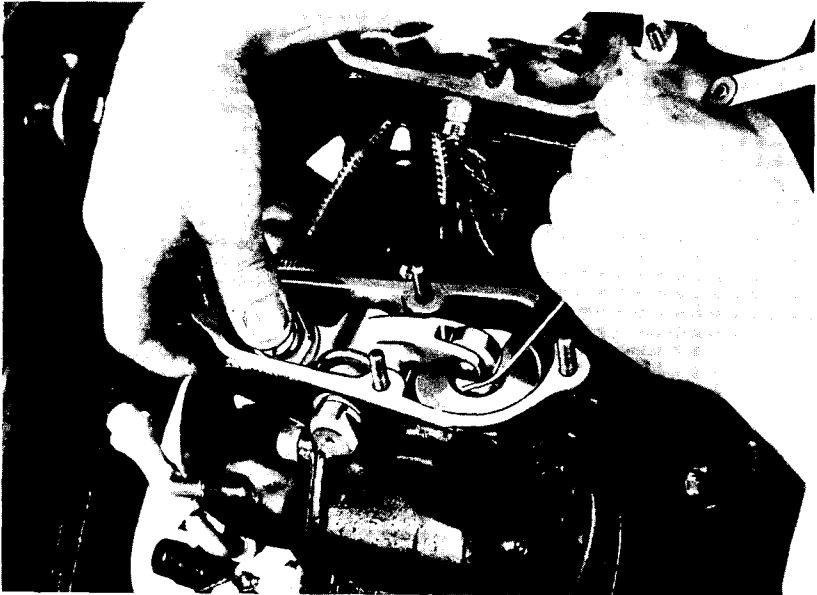

RA PD 309848

Figure 146 – Measuring Tappet Clearance

lutions in the reverse direction, and stop exactly at zero. At this point, the timing disk should indicate the same reading after top center as it did before top center when the dial indicator was originally set at zero. If the reading is not the same, adjust the timing disk pointer to a position midway between the two readings obtained, and repeat the check.

c. Time Valves.

(1) **SET NO. 9 CYLINDER ROCKER ARM.** Using the screwdriver (41-S-1725), turn the adjusting screw of No. 9 cylinder intake valve rocker arm in until about $\frac{1}{8}$ inch of the adjusting screw protrudes above the rocker arm or above the lock nut, depending upon which type of rocker arm is used on the engine.

(2) **SET NO. 1 CYLINDER ROCKER ARMS.** Turn the crankshaft in the normal direction of rotation until No. 9 cylinder intake valve just begins to open. Tap the push rod end of the rocker arms on No. 1 cylinder with a fiber hammer to seat the push rod sockets. Set the clearance of both valves of No. 1 cylinder at 0.070 inch, using the feeler gage (41-G-412-75) (fig. 146).

(3) **LOCATE VALVE OPENING.** Clasp the rocker arm roller of No. 1 intake valve between the fingers, and turn the crankshaft in the normal direction of rotation. As soon as the rocker arm roller binds,

**ORDNANCE MAINTENANCE — 9-CYLINDER, RADIAL, GASOLINE ENGINE
(CONTINENTAL MODEL R975-C1)**

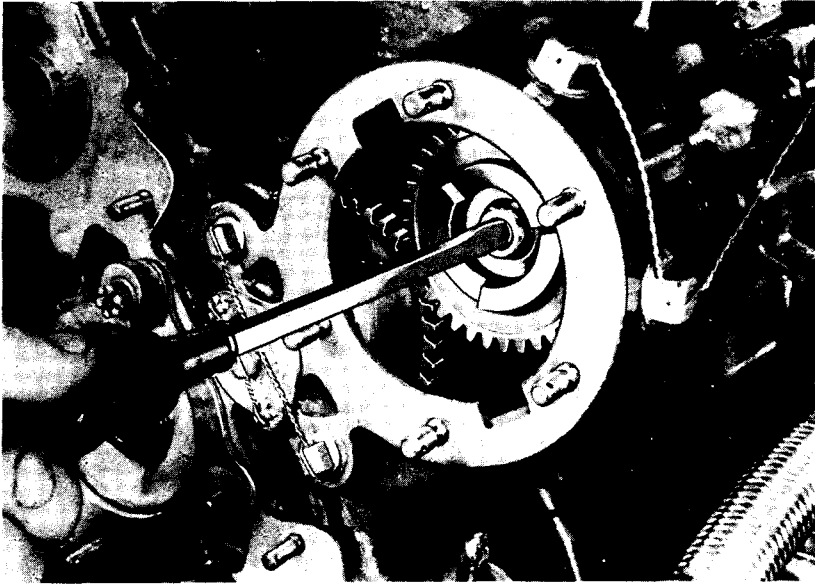

RA PD 309850

Figure 147 — Disengaging Timing Serrations

loosen the lock nut on the rear end of the cranking motor shaft bolt. Insert a screwdriver in the slot provided on the end of this bolt, and push the bolt forward to disengage the timing serrations on the front end of the bolt (fig. 147).

(4) **SET CRANKSHAFT.** While holding the timing serrations disengaged, turn the crankshaft until the timing disk and pointer register the proper setting for intake valve opening. This setting is dependent upon the type of cam used in the engine. Early R975-C1 engines (previous to engine No. 309485) have a cam (C.M.C. No. 200752) identified by use of bolts in the cam hub, and are timed in accordance with the following specifications:

Timing clearance, engine cold, int and ext.	0.070 in.
Intake valve opens	3 deg. A.T.C.
Intake valve closes	34 deg A.B.C. \pm 4 deg
Exhaust valve opens	61 deg B.B.C. \pm 4 deg
Exhaust valve closes	8 deg A.T.C.

Late R975-C1 engines (engine No. 309485 and all subsequent engines) have a cam (C.M.C. No. 202347) identified by use of rivets

R975-C1 ENGINE (CONTINENTAL)

in the cam hub, and are timed in accordance with the following specifications:

Timing clearance, engine cold, int and ext.	0.070 in.
Intake valve opens	8 deg B.T.C. \pm 4 deg
Intake valve closes	34 deg A.B.C. \pm 4 deg
Exhaust valve opens	56 deg B.B.C. \pm 4 deg
Exhaust valve closes	19 deg A.T.C. \pm 4 deg

If a new cam has been installed in an early model engine, this fact may be determined by reference to the engine name plate. With the new cam, the name plate reads "I. C. 34 \pm 4 deg A.B.C." as compared with "I. C. 35 deg A.B.C." on the name plate of an engine with the old type cam installed. If the engine has a riveted type cam, set the crankshaft to 8 degrees before top center (8 deg B.T.C.) while holding the timing serrations disengaged. If the bolted type cam is used, set the crankshaft to 3 degrees after top center (3 deg A.T.C.) while the timing serrations are held disengaged.

(5) **ENGAGE TIMING SERRATIONS.** Permit the cranking motor shaft bolt to slip back into position, reengaging the timing serrations. Tighten the nut on the rear end of the bolt. Back it off one-half turn, and attempt to rotate the bolt to make sure the serrations are in mesh. Retighten the nut. Rotate the crankshaft again in the normal direction of rotation, and note the points at which each of the No. 1 cylinder valves open and close. These points must be within the limits specified in the previous subparagraph. Lock the cranking motor shaft nut with a cotter pin when the correct valve timing has been obtained. Before starting to insert the cotter pin, spread a clean lintless cloth around the end of the cranking motor jaws so that the pin will not fall into the rear case if dropped. Remove the cloth when the pin is installed.

d. Adjust Valve Clearances.

(1) **SET CLEARANCES.** As soon as the valves are timed correctly, turn the crankshaft until the piston of No. 1 cylinder is at top center with both valves closed. Insert a 0.006-inch clearance feeler (41-G-412-75) under the rocker arm roller, and tighten the valve clearance adjusting screw with the screwdriver (41-S-1725) until the feeler is a tight fit between the roller and the valve stem. Tighten the clamping screw with wrench (41-W-3812) (fig. 148), or tighten the lock nut (fig. 149), whichever is used on the rocker arm. If a lock nut is used on the adjusting screw, tighten with a torque-indicating wrench (41-W-3630) to 600 to 650 inch-pounds.

(2) **BLANK OFF OILHOLES.** The valve clearance adjusting screw on a rocker arm using the clamping screw is marked on its outer face in line with each of three radially drilled oilholes in the screw.

**ORDNANCE MAINTENANCE — 9-CYLINDER, RADIAL, GASOLINE ENGINE
(CONTINENTAL MODEL R975-C1)**

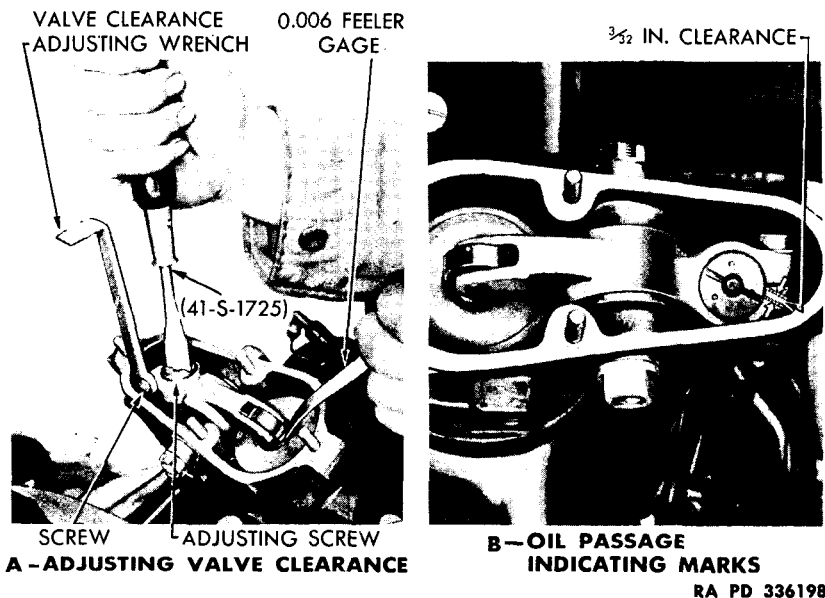

Figure 148 — Adjusting Valve Clearance (Previous to Engine No. 305029)

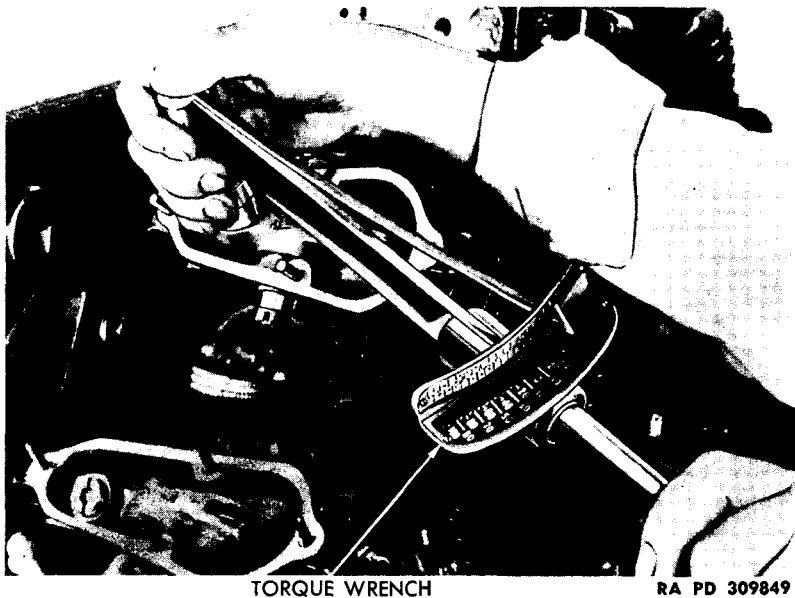

Figure 149 — Tightening Tappet Adjusting Screw Lock Nut

R975-C1 ENGINE (CONTINENTAL)

Care must be observed that the oilhole, as indicated by the marking on the outer face of the adjusting screw, is not permitted to line up with the split in the rocker arm and thus discharge pressure oil into the rocker box. Marks on the face of the screw must indicate that all oilholes are blanked off by at least $\frac{3}{32}$ inch from the nearest edge of the split in the arm. If any mark falls too close to the split when the correct clearance has been obtained, turn in the direction that will require the least turning to blank off the oilhole by $\frac{3}{32}$ inch. This precaution needs to be observed only where split-type rocker arms are used.

(3) **COMPLETE ADJUSTMENT.** Proceed with adjustment of clearance on the remaining valves, taking the cylinders in order of their firing (1-3-5-7-9-2-4-6-8), and repeating the operations explained for No. 1 cylinder. Secure clamping screws with lock wire, when used, to prevent their loosening in operation.

e. **Assemble Rocker Box Covers.** Use new gaskets, and install covers on all rocker boxes except No. 1 cylinder. Fasten the covers with flat washers, nuts tightened to 80 to 90 inch-pounds, and lock washers.

f. **Select Magnetos.** Two types of magnetos are used on R975-C1 engines, one a Scintilla, and the other an American Bosch. The magneto for use on any particular engine will be determined by referring to the engine name plate. If the name plate is stamped with 4 degrees in the spark advance block, use Bosch magnetos; if it is stamped with 25 degrees use Scintilla magnetos.

g. **Scintilla Magneto Installation.**

(1) **SET CRANKSHAFT.** Turn the crankshaft in the normal direction of rotation approximately three-fourths of a revolution beyond the point where No. 1 cylinder intake valve starts to open, and stop at exactly 25 degrees before top center as indicated by the timing disk and pointer. In this position, the piston of No. 1 cylinder is on the compression stroke and both valves are completely closed. It is important to note that backlash of the gears will throw out the timing unless the full advance firing position is attained with the crankshaft rotating in the clockwise direction.

(2) **INSERT MAGNETO.** Place a new gasket on the magneto flange, and apply a heavy grade of petrolatum to the spline of the magneto coupling gear. Turn the magneto drive shaft until the engraved marks on the teeth of the large distributor gear are opposite the corresponding marks on the inside of the front end plate. Hold in this position and mount on the engine (fig. 150).

(3) **ALINE TIMING MARKS.** Move the body of the magneto through the range provided in the elongated slots on the mounting

**ORDNANCE MAINTENANCE — 9-CYLINDER, RADIAL, GASOLINE ENGINE
(CONTINENTAL MODEL R975-C1)**

Figure 150 — Installing Magneto (Scintilla)

flange, until the timing marks on the large distributor gear are exactly opposite the corresponding marks on the inside front end plate. Use a straightedge to obtain an accurate alinement of these marks. If the marks fail to aline within the full travel of the slots, withdraw the magneto a sufficient amount to permit rotating the splined drive shaft one tooth and reengage.

(4) **LOCK MAGNETO.** When the correct timing is obtained, lock the magneto in place by tightening nuts on the flange studs. Secure the nuts with lock wire.

(5) **POINT SETTING.** It may be noted that the contact breaker screw points are not just beginning to open at a crankshaft setting of 25 degrees before top center, which is the point at which the timing marks on the gear aline with those on the inside of the front end plate. Actually when the engine is being turned over with the cranking motor or operating at very slow speeds, the breaker points will not open and cause the magneto to fire until the piston reaches approximately 4 degrees before top center. However, when the engine reaches normal operating speed, the automatic advance mechanism will cause the breaker points to open at the same instant the timing marks are in line, which is 25 degrees before top center and the desired sparking

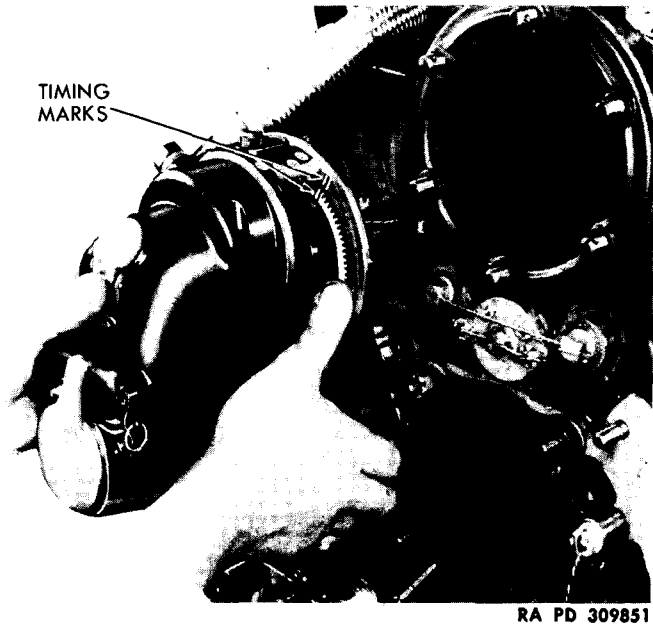
R975-C1 ENGINE (CONTINENTAL)

position for operation of the engine. The full advance position is used as preferable when setting the Scintilla-type magneto since any variation between the automatic advance mechanisms in the magnetos will occur on the retard side and not on the advance side, thus maintaining the original full advance firing setting.

h. Bosch Magneto Installation.

(1) **SET CRANKSHAFT.** Turn the crankshaft in the normal direction of rotation approximately three-fourths of a revolution beyond the point where No. 1 cylinder intake valve starts to open, and stop at exactly 4 degrees before top center as indicated by the timing disk and pointer. In this position, the piston of No. 1 cylinder is on the compression stroke, and both valves are completely closed. It is important to note that backlash of the gears will throw out the timing unless the full advance firing position is attained with the crankshaft rotating in the clockwise direction.

(2) **INSERT MAGNETO.** Place a new gasket on the magneto flange, and apply a heavy grade of petrolatum to the spline of the magneto coupling gear. Turn the magneto drive shaft until the white timing dot on the distributor drive gear aligns with the red dot on the housing flange. Hold in this position and mount on the engine (fig. 151).

(3) **ALINE TIMING MARKS.** Assemble nuts on the studs, and tighten finger-tight. Move the body of the magneto through the range provided in the elongated slots on the mounting flange until a straightedge placed across the step of the timing collar coincides with the timing marks on the outer rim of the housing (fig. 152).

(4) **LOCK MAGNETO.** When the correct timing is obtained, lock the magneto by tightening nuts on the flange studs. Secure the nuts with lock wire.

(5) **POINT SETTING.** Location of timing marks used to set the Bosch magneto is established with the breaker point cam in the full retard position. Since these magnetos are installed on the engine with the crankshaft setting at 4 degrees before top center of No. 1 cylinder, there may exist some doubt as to what position the spark occurs with the engine operating at normal speed. The automatic spark advance mechanism in the Bosch magneto is designed to advance the sparking point at total of 21 degrees from the retard position at idle speed to the fully advanced position around 1,800 revolutions per minute. This will mean, that at normal operating speeds, the ignition spark is occurring at 25 degrees before top center, which is the same point at which the Scintilla magneto fires at normal operating speeds.

ORDNANCE MAINTENANCE — 9-CYLINDER, RADIAL, GASOLINE ENGINE
(CONTINENTAL MODEL R975-C1)

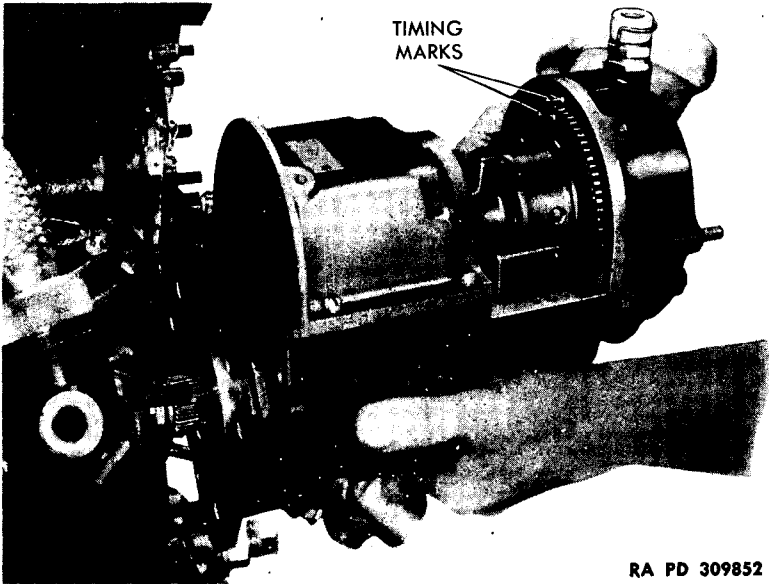

RA PD 309852

Figure 151 — Installing Magneto (Bosch)

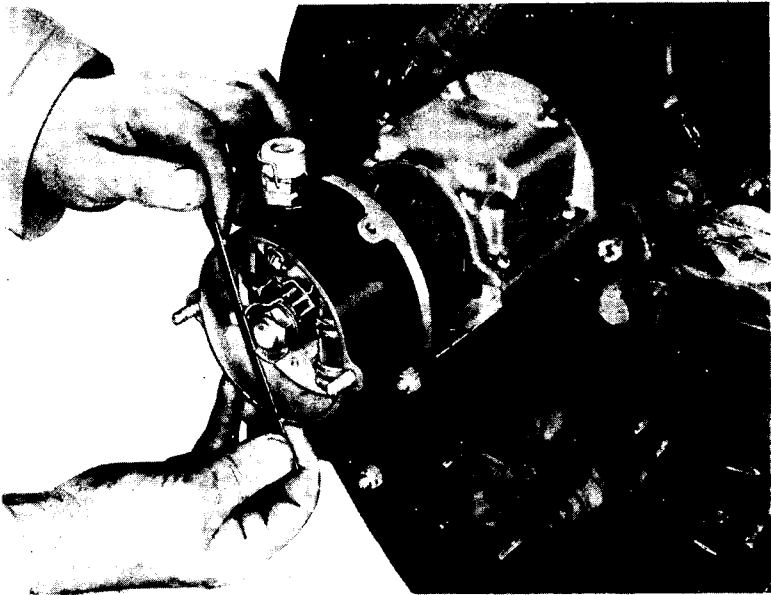

RA PD 309853

Figure 152 — Timing Bosch Magneto With Use of Straightedge

R975-C1 ENGINE (CONTINENTAL)

i. Install Front Spark Plugs. Install all front spark plugs, and connect ignition cables, observing the instructions and precautions outlined in paragraph 33 u.

j. Tighten Crankshaft Thrust Bearing Nut. Place the crankshaft thrust bearing nut lug wrench (41-W-871-35) over the crankshaft thrust bearing nut, and install the timing fixture (41-F-2997-84) to hold the crankshaft from turning. Tighten the nut as far as possible by hand. Complete tightening to 425 to 450 foot-pounds.

k. Install Cowl. Set the cowl in place, and fasten to bosses on the front of the rocker boxes with bolts, flat washers, nuts, and cotter pins. Use a torque wrench, and tighten nuts to 80 to 85 inch-pounds before installing cotter pins. Use a screwdriver, and engage the toothed fasteners which secure the intercylinder and cylinder head air deflectors to the cowl.

l. Install Support Tube. Slide the support tube through the cowl, and center in the front section bracket. Tighten the support cap nuts, and secure with lock wire.

m. Assemble Hub, Flywheel, and Fan. Assemble the flywheel hub rear cone over the crankshaft and down against the thrust bearing nut. Screw the lifting eye to the flywheel hub, attach to a chain hoist, and suspend over the crankshaft. Aline splines, and lower the flywheel and fan assembly in place. Note that splines on the crankshaft and flywheel will aline in one position only. With the fan and flywheel in place, start the front cone nut on the crankshaft (fig. 153). Check the front cone halves to determine that each bears the same identifying number. Should it be necessary to use a new cone, saw the two halves to separate, and file the ends smooth. It is particularly important that both halves of the cone bear the same identifying number. Set the cone halves over the nut and hold while turning the nut in. Place a $\frac{3}{4}$ -inch round bar through holes in the nut, and obtain leverage with a 4-foot length of pipe. Block the flywheel from turning with a piece of wood, and turn the nut to aline the retaining pin holes at tight position. Insert the retaining pin from the inside, lay a flat washer over the outlet end, and secure with a cotter pin.

n. Install Exhaust Manifolds. Assemble individual parts of the manifold halves, and install clamps loosely. Use new gaskets on the exhaust elbow mounting flanges, and assemble the manifolds to the engine. Place nuts on the exhaust elbow studs and draw up snug, but not tight. Tighten clamp screws to where the clamps can just be turned by hand. It is important that clamps are not tightened fully against the pipes when the pipes are cold. At operating temperatures, the exhaust pipes expand considerably, and clamp screws may

ORDNANCE MAINTENANCE — 9-CYLINDER, RADIAL, GASOLINE ENGINE
(CONTINENTAL MODEL R975-C1)

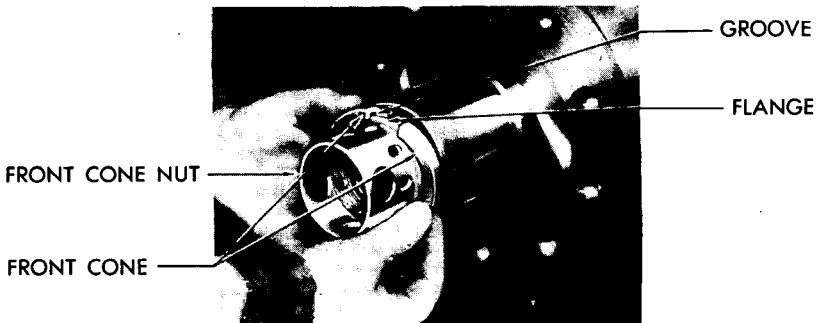

1. INSTALLING FRONT CONE

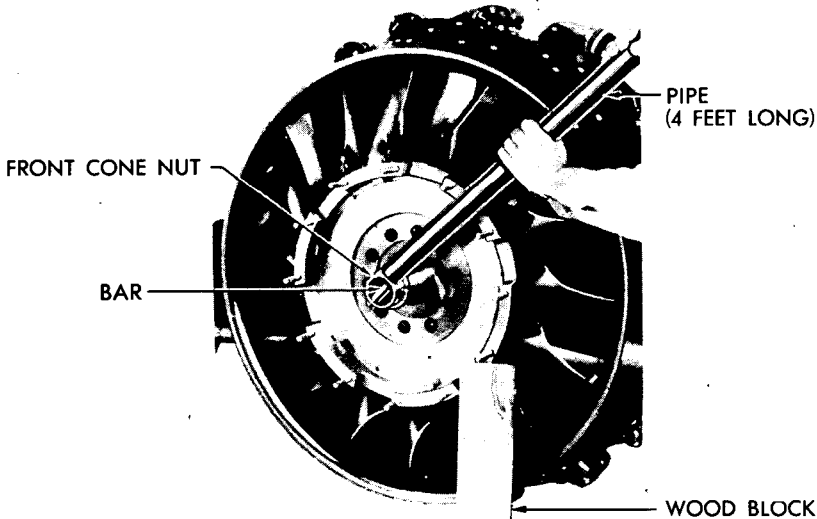

2. TIGHTENING FRONT CONE NUT

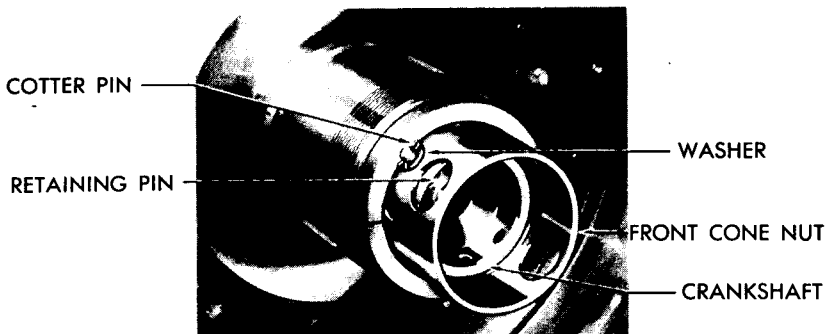

3. FRONT CONE NUT LOCKED IN POSITION

RA PD 53593

Figure 153 — Installing Front Cone and Nut

R975-C1 ENGINE (CONTINENTAL)

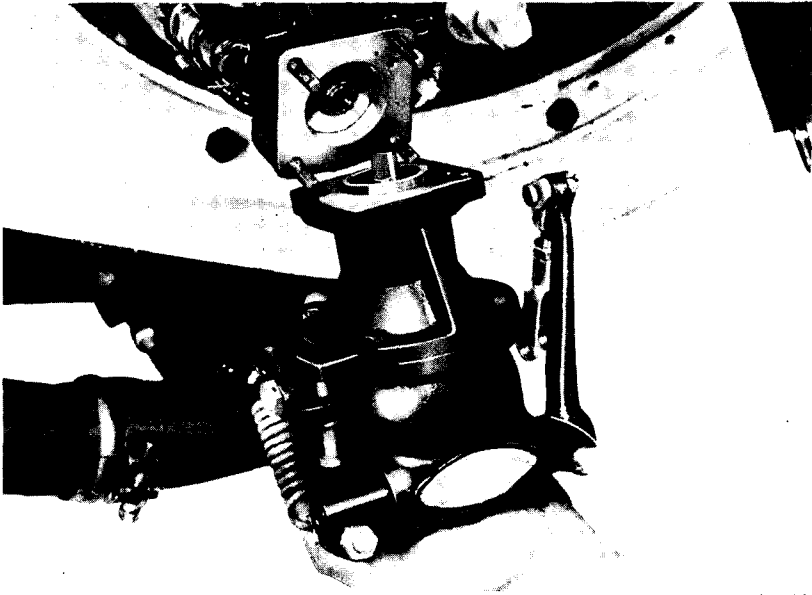

RA PD 309781

Figure 154 – Installing Governor Assembly

be overstressed if the clamps are tightened fully in the cold position. Tighten exhaust elbow flange nuts to 175 to 200 inch-pounds, and secure with lock wire.

o. Install Engine Support Beam. Attach lifting sling to the rocker arm hub bolt nut on the exhaust valve rocker arm of No. 9 cylinder and the intake rocker arm hub bolt of No. 2 cylinder. Support weight of the engine with a chain hoist, and remove bolts holding it to the overhaul stand. Place the support beam on the engine, and secure with the bolts, flat washers, castellated nuts, and cotter pins. Tighten mounting bolts to 400 to 425 inch-pounds with a torque-indicating wrench. If the cotter pin holes do not line up when a nut is fully tightened, remove the nut and either try another one or use a different washer.

p. Install Three-way Accessory Drive Housing. Use a new gasket on the flange, and install the three-way accessory drive housing assembly on the crankcase rear section. Fasten the housing with flat washers and nuts. Secure the three outside nuts with lock wire and the other two with cotter pins. Use a new gasket, and assemble the auxiliary drive replacement cover. Fasten the cover with flat washers, nuts, and palnuts.

**ORDNANCE MAINTENANCE — 9-CYLINDER, RADIAL, GASOLINE ENGINE
(CONTINENTAL MODEL R975-C1)**

Figure 155 — Installing Generator

q. Install Governor. Place a new gasket on the governor drive flange, align oilhole in the drive flange with that in the governor flange, and install the governor in place on the engine. Fasten with four washers, nuts, and palnuts.

r. Install Generator. Use a new gasket, align splines on the drive shaft, and install the generator (fig. 155). The terminals on the rear of the generator should be toward the bottom of the engine. Fasten securely to the rear section with four nuts and lock wire, using the wrench (41-W-636-550).

s. Install Cranking Motor. Place a new gasket on the engine mounting flange, and measure distance from the outside face of the gasket to the tip of the engine jaw with a depth gage. Check corresponding distance on the cranking motor jaw, and determine that $\frac{1}{16}$ - to $\frac{1}{8}$ -inch clearance will be provided between the two jaws when the cranking motor is installed. Hold cranking motor so that the cranking unit is toward the top of the engine, and assemble in place (fig. 156). Assemble washers and nuts on the studs, and tighten with the wrench (41-W-871-45) to 225 to 250 inch-pounds. Secure the nuts with lock wire.

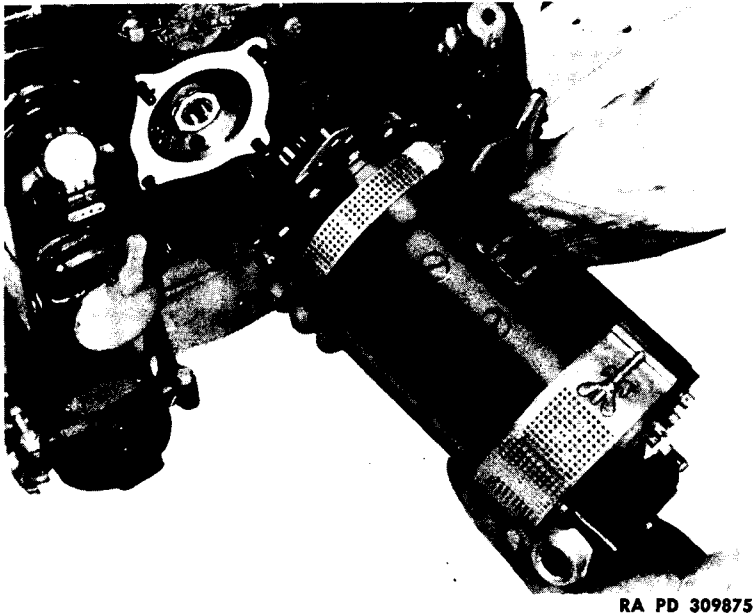
R975-C1 ENGINE (CONTINENTAL)

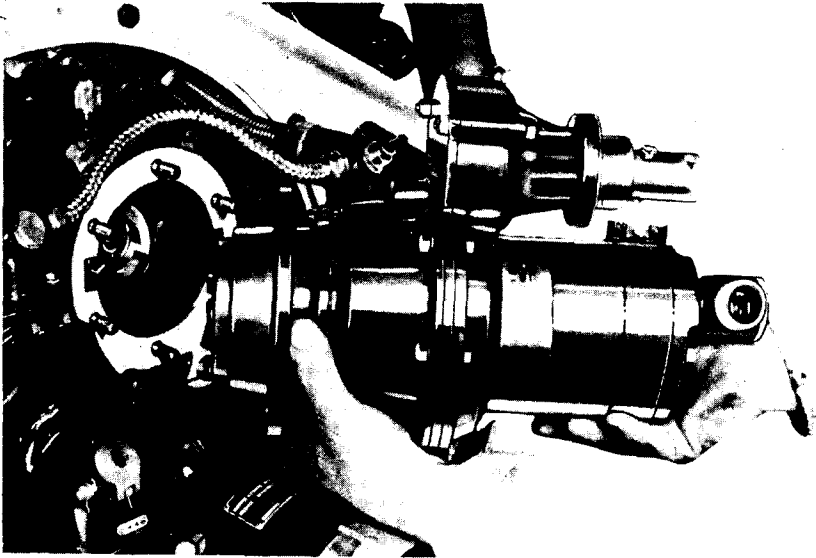

RA PD 309876

Figure 156 — Installing Cranking Motor

t. **Install Cranking Motor and Generator Support Bracket.** Slide the generator band, with split at bottom, onto rear end of generator. Remove clamping bolts from the cranking motor band, and assemble the band to the rear of the cranking motor. Reinstall clamping bolts loosely. Hold brackets in place, and install the retaining bolts and nuts. Secure the nuts with cotter pins. Brackets go on the front of the cranking motor band and the back of the generator band. Tighten clamping bolts on both bands after the brackets have been assembled and tightened.

u. **Install Carburetor, Throttle Box, and Carburetor Elbow.** These parts will be installed on the engine as a unit. Place a new gasket on the carburetor elbow mounting flange, and install the unit on the engine. Secure with washers, nuts, and lock wire. Attach the support bracket with the two washers, bolts, and lock wire. Connect the throttle rod yoke pin, and install a cotter pin. **NOTE:** *If carburetor air horn drain plug screen needs replacing, use screen A158029.*

v. **Install Fuel Pump (Romec).** Place a new gasket on the flange, and engage the square-type drive shaft in the three-way accessory drive housing. Fasten with washers, nuts, and lock wire.

w. **Install Fuel Pump (A-C).** Use a new gasket on the flange, and install the A-C fuel pump and adapter assembly on the three-way accessory drive housing. Fasten with washers, nuts, and lock wire.

**ORDNANCE MAINTENANCE — 9-CYLINDER, RADIAL, GASOLINE ENGINE
(CONTINENTAL MODEL R975-C1)****Section IX****TESTING AFTER OVERHAUL****35. METHOD.**

a. General. After each overhaul, the engine will be given a block test run in accordance with the following schedule and procedure. The purpose of test operation after overhaul is to "run-in" new parts installed, and to demonstrate that the engine may be expected to operate satisfactorily when installed in a vehicle.

b. Preliminary. The engine will be attached to a suitable dynamometer stand and operated under loads as specified in Test Schedule (par. 36). A baffle wall should be installed separating test room in 2 compartments, thereby completely eliminating recirculation of air across engine. A calibrated test club propeller designed to absorb 400 brake horsepower at 2,400 revolutions per minute may be used to apply load to engine in the event dynamometer equipment is not available. The term "brake horsepower," as used herein, means net brake horsepower available at the propeller shaft drive flange when the engine is equipped with all power consuming accessories. A positive-type pressure gage is to be used for measuring oil pressure. Before starting engine, check all items vital to safe operation such as fuel lines, oil lines, oil supply, magneto ground wires, throttle controls, and mounting bolts. Make sure test cell observation window and control room are neat and clean. Have fire extinguishers handy. On starting engine, enter time, initial speed, and oil pressure. Oil pressure must register within 30 seconds after starting engine and be not less than 30 pounds at 800 revolutions per minute. Check cylinders for firing. Prior to starting of the engine, set the governor at wide open throttle until the engine has completed its final run-in period. After the run-in adjust the governor to 2,400 revolutions per minute with no load.

c. Procedure. Enter time, speed, oil pressure, oil temperature, manifold pressure, and dynamometer scale reading as soon as engine is stabilized at start of each period. Take 3 complete readings for period 11. Run 5 minutes at full throttle (period 12), and determine proper speed for period 13 if a test club is used instead of a dynamometer. Take complete readings during period 13, and check oil consumption. Check acceleration, idle, and idle oil pressure at end of run. Adjust engine idle (for shifting gears only) to 500 revolutions per minute.

d. Magneto Check Make two magneto checks, one during period 9, and one at 2,100 revolutions per minute after completing

R975-C1 ENGINE (CONTINENTAL)

period 13. The drop in engine speed should not exceed 100 revolutions per minute when switched to one magneto.

e. **Oil Pressure.** After one hour, or beginning of 1,800 revolutions per minute run, adjust oil pressure to 65 pounds per square inch by adjusting by-pass relief valve.

f. **Fuel Pressure.** Fuel pressure should be set at 3½ to 5 pounds per square inch at 1,200 to 2,400 revolutions per minute, if engine is equipped with Romeo fuel pump. If engine is equipped with A.C. fuel pump, no adjustment is necessary.

g. **Cylinder Head Temperature.** Never allow head temperature to go over 500° F. as measured at rear spark plug gasket.

36. TEST SCHEDULE.

Period	Time (Min)	Speed (rpm)	Man Press (In Hg Approx)	Power (B H P Approx)
1	10	Warm up to 1,200		None
2	10	1,200	13-14	50
3	10	1,500	17-18	75
4	15	1,600	19-20	95
5	15	1,700	20-21	110
6	15	1,800	21-22	130
7	20	1,900	23-24	155
8	20	2,000	25-26	180
9	20	2,100	27-28	210
10	30	2,200	30-31	240
11	30	2,300	33-34	280
12	5	2,400	35-36	345
13	30	2,340 (97.5%)	34-35	295
14	10	Cool off period (Progressive reduction of engine speed from 1,200 rpm)		

37. INSPECTION.

a. **General.** During the last 10 minutes of test run, engine is to be carefully inspected and notations made of oil leaks or other evidence of difficulty. If oil consumption check showed usage in excess of 5 pounds per hour, determine the cause. Remove No. 1 cylinder, and inspect the piston rings for "feathering," "scuffing," or evidence of incomplete or improper seating within the cylinder. If no difficulties are noted, it may be assumed that other cylinders are in good condition, provided other indications are normal. Should inspection of the No. 1 cylinder and pistons indicate further investigation, remove the remaining cylinders. Following disassembly and repair or replacement of engine parts, engine will be given a "penalty" test run under same conditions as first test run.

ORDNANCE MAINTENANCE — 9-CYLINDER, RADIAL, GASOLINE ENGINE
(CONTINENTAL MODEL R975-C1)

Section X

TABLE OF LIMITS

38. TABLE OF LIMITS.

a. Clearance Values.		Replace Beyond	Reft to	
POINT OF CLEARANCE			Min	Max
1	Rocker roller hub and pin (diameter)	—	0.000	0.0025L
2	Rocker roller hub and roller (diameter)	0.005L	0.0015L	0.0035L
3	Rocker roller hub and rocker arm (side clearance)		Rivet tight	
4	Rocker roller and rocker arm (side clearance)	0.025	0.009	0.015
5	Rocker box & rocker brg (side clear. before clamping)	0.010	0.004	0.010
6	Rocker bearing bore & rocker bolt (diameter)	0.005L	0.000	0.001L
7	Rocker bearing OD & rocker arm (diameter)	—	0.001T	0.002T
8	Rocker bolt & rocker box (diameter)	—	0.0005L	0.003L
9	Valve spring (outer)			
	Compressed to 1.34 in. height	90 lb	94.8 lb	104.8 lb
	Compressed to 1.96 in. height	50 lb	54.5 lb	66.5 lb
10	Valve spring (intermediate)			
	Compressed to 1.40 in. height	69 lb	73.0 lb	80.6 lb
	Compressed to 1.96 in. height	38 lb	42.0 lb	51.5 lb
11	Valve spring (inner)			
	Compressed to 1.32 in. height	35 lb	38.6 lb	42.6 lb
	Compressed to 1.88 in. height	20 lb	22.4 lb	27.4 lb
12	Valve guide and valve (intake diameter)	0.005L	0.003L	0.0035L
13	Valve guide and valve (exhaust diameter)	0.008L	0.005L	0.0065L
14	Valve guide and cylinder head (intake)	—	0.001T	0.0025T
15	Valve guide and cylinder head (exhaust)	—	0.002T	0.0035T
16	Valve seat and cylinder head (exhaust)	—	0.011T	0.015T
17	Valve seat and cylinder head (intake)	—	0.014T	0.017T
18	Valve tappet ball socket spring			
	Compressed to 2.18 in. height	6 lb	7.74 lb	9.46 lb
19	Valve tappet guide and valve tappet (diameter)	0.003L	0.0005L	0.0015L
20	Valve tappet guide & crankcase (diameter)	—	0.001T	0.003T
21	Valve tappet roller and roller pin (diameter)	0.006L	0.003L	0.0045L
22	Piston & piston pin (diameter)	0.003L	0.000	0.001L
23	Piston groove No. 1 (top) & ring-side clearance	—	0.0055	0.007
24	Piston groove No. 2 & ring (side clearance)	—	0.004	0.0055
25	Piston groove No. 3 & ring (side clearance)	—	0.0025	0.004
26	Piston groove No. 4 & ring (side clearance)	—	0.0025	0.004
27	Piston groove No. 5 & ring (side clearance)	—	0.0025	0.004

R975-C1 ENGINE (CONTINENTAL)

POINT OF CLEARANCE		Replace Beyond	Min	Refit to Max
28	Piston ring gap (ring in std 5.000-inch diameter gage)	—	0.025	0.031
29	Piston forged (center of skirt & cylinder) (diameter)	0.035L	0.025L	0.029L
29A	Piston cast (center of skirt & cylinder) (diameter)	0.035L	0.015L	0.019L
30	Piston pin bushing and master and art. rods (diameter)	—	0.0045T	0.0065T
31	Piston pin & bushing (diameter)	0.005L	0.0015L	0.003L
31A	Piston pin & retainer (end clearance)	0.035	0.003	0.027
32	Master rod (end clearance on crankpin)	—	0.017	0.019
32A	Master rod (twist or misalignment)	Maximum	0.0045 in 6 in.	
32B	Articulated rod (twist or misalignment)	Maximum	0.0045 in 6 in.	
33	Crankpin bearing & master rod (diameter)	—	0.001T	0.003T
34	Crankpin bearing & crankpin (diameter)	0.006L	0.003L	0.0042L
35	Knuckle pin & master rod (diameter)	0.001L	0.000	0.0008T
36	Knuckle pin bushing & master rod (side clear.)	0.020	0.006	0.014
37	Knuckle pin bushing & knuckle pin (diameter)	0.004L	0.0015L	0.0025L
38	Knuckle pin bushing & art rod (diameter)	—	0.0045T	0.0065T
39	Main bearing support & crankcase front section (diameter)	—	0.003T	0.003L
40	Front main bearing support & bearing ring (diameter)	—	0.003T	0.006T
41	Front main bearing & bearing ring (diameter)	—	0.002T	0.0015L
42	Front main bearing & crankshaft (diameter)	—	0.0002T	0.0007T
43	Allowable run-out of crankshaft at center bearing journal when supporting at thrust & rear main bearings	0.004 full indicator reading		
44	Thrust bearing & front section (diameter)	0.0022L	0.0002L	0.0022L
45	Thrust bearing & crankshaft (diameter)	—	0.0002T	0.0009L
46	Thrust bearing & front cover clamp (shim to obtain)	—	0.005T	0.007T
47	Allowable run-out of crankshaft at thrust bearing journal when supported at front main bearing & rear main bearing	0.004 full indicator reading		
48	Crankcase front cover & front cover sleeve (dia)	—	0.003T	0.006T
49	Main bearing support & crankcase main section (diameter)	—	0.000	0.006L
50	C'shaft thrust bearing nut & oil seal ring (side clearance)	0.010	0.002	0.006
51	Thrust bearing (total end movement)	0.020	0.006	0.010
52	Crankshaft front & crankshaft rear (diameter before tightening screw)	0.001L	0.001T	0.001L
52A	Crankcheek cap screws (tighten nut to obtain elongation)	—	0.005	0.007

**ORDNANCE MAINTENANCE — 9-CYLINDER, RADIAL, GASOLINE ENGINE
(CONTINENTAL MODEL R975-C1)**

	POINT OF CLEARANCE	Replace Beyond	Reft to	
			Min	Max
53	Crankshaft rear end plug & crankshaft (diameter)	—	0.000	0.002T
54	Crankshaft gear hub & crankshaft gear (diameter)	0.005L	0.001L	0.003L
55	Crankshaft gear hub & crankshaft gear (side clearance)	0.010	0.003	0.005
56	Crankshaft gear spring Compressed to 0.71 in. height	170 lb	181 lb	191 lb
57	Crankshaft bearing & rear crankshaft (diameter)	0.0055L	0.002L	0.004L
58	Crankshaft bearing & crankcase main section (diameter)	—	0.002T	0.004T
59	Rear crankshaft & counterweight pin bushing (diameter)	—	0.001T	0.0025T
60	Rear crankshaft & counterweight (side clear total)	0.015	0.006	0.012
61	Rear counterweight & stop (clearance)	0.060	0.041	0.057
62	Rear counterweight & bushing (diameter)	—	0.0015T	0.003T
63	Cranking motor drive gear bushing & diffuser section (diameter)	—	0.001T	0.003T
64	Cranking motor drive gear & bushing (diameter)	0.006L	0.0025L	0.004L
65	Cranking motor shaft bushing & shaft (diameter)	0.006L	0.0025L	0.004L
66	Cranking motor shaft bushing & rear section (diameter)	—	0.001T	0.003T
67	Cranking motor shaft (end clearance)	0.050	0.013	0.045
68	Cranking motor drive & crankshaft gear (backlash)	0.020	0.008	0.016
70	Oil suction strainer spring Compressed to 3.125 in. (height)	5 lb	6 lb	—
71	Governor drive gear & governor shaft gear (backlash)	0.018	0.004	0.012
72	Oil pump idler shaft & oil pressure pump body (diameter)	0.003L	0.001L	0.0025L
73	Oil pump idler shaft & pump spacer (diameter)	0.0025L	0.0007L	0.0017L
74	Oil sump connection adapter & crankcase main section (diameter)	0.034L	0.004L	0.034L
75	Oil sump connection & oil seal (diameter)	—	0.006T	0.061T
76	Oil pressure relief valve seat & oil pump body (diameter)	—	0.002T	0.003T
77	Oil pressure relief valve spring compressed to 1.25 in. (height)	4.0 lb	4.95 lb	6.05 lb
78	Oil pump drive shaft & oil pump idler shaft (backlash)	0.005	0.003	0.004
79	Oil pressure pump body & oil pump idler shaft (end clearance)	0.005	0.001	0.0025
80	Oil pump body & oil pump idler shaft (diameter)	0.0025L	0.001L	0.0025L

R975-C1 ENGINE (CONTINENTAL)

	POINT OF CLEARANCE	Replace Beyond	Min	Reft to Max
81	Oil pump body & pump gear (side clearance)	0.005	0.002	0.0035
82	Oil pressure pump body & oil pump idler shaft (side clearance)	0.003	0.001	0.0025
83	Oil pump body & oil pump idler gear (side clearance)	0.005	0.002	0.0035
84	Oil pump body & oil pump drive shaft (diameter)	0.003L	0.001L	0.002L
85	Oil pump body & governor drive shaft bushing (diameter)	—	0.001T	0.003T
86	Oil pump idler gear & body (end clearance)	0.005	0.002	0.0035
87	Oil pump drive shaft & oil pressure pump body (diameter)	0.003L	0.001L	0.0025L
88	Oil pump drive gear & oil pressure pump body (diameter)	0.003	0.001	0.003
89	Oil pump drive shaft & oil pump gear spacer (diameter)	0.0025L	0.0007L	0.0017L
90	Oil pump drive shaft gear & oil pressure pump body (side clearance).....	0.0035	0.002	0.0035
91	Oil pump gear & oil pump idler gear (backlash)	0.008	0.004	0.006
92	Oil pump body bushing & governor drive shaft (diameter)	0.005L	0.001L	0.003L
93	Impeller shaft rear ball bearing (side clearance)	0.006	0.004	0.006
94	Ball bearing & impeller shaft (diameter)	—	0.0001T	0.0004T
95	Impeller shaft bearing support & bearing (diameter)	0.0015L	0.0005L	0.0013L
96	Impeller shaft rear bearing & cage (diameter)	0.0015L	0.0005L	0.0013L
97	Impeller oil seal ring (side clearance) ..	0.010	0.006	0.008
98	Impeller oil seal ring (gap).....	0.008	0.000	0.006
99	Impeller & impeller shaft.....	(Impeller splines)	must be tight fit on	
100	Impeller shaft nut lock & nut (end clearance)	0.002L	0.000	0.002L
101	Impeller shaft nut lock (side clearance)	—	0.000	0.003
102	Impeller & supercharger housing (clearance front)	—	0.022	0.032
103	Impeller & supercharger housing (clearance rear)	—	0.018	0.072
104	Impeller drive gear hub bearing clearance between shaft support and diffuser section	—	0.000	0.008T
105	Impeller drive gear pinion & bearing (end clearance)	0.025	0.008	0.016
106	Supercharger intermediate gear & bushing (diameter)	—	0.001T	0.003T
107	Impeller drive gear hub bearing & impeller drive gear bushing (diameter) .	0.006L	0.003L	0.004L
108	Impeller shaft gear & drive gear (backlash)	0.012	0.002	0.008

**ORDNANCE MAINTENANCE — 9-CYLINDER, RADIAL, GASOLINE ENGINE
(CONTINENTAL MODEL R975-C1)**

	POINT OF CLEARANCE	Replace Beyond	Refit to	
			Min	Max
109	Impeller drive pinion & crankshaft gear (backlash)	0.025	0.010	0.018
110	Cam drive pinion spring compressed to 1.375 in. (height)	6 lb	8 lb	—
111	Cam hub & cam bearing (diameter)	—	0.0015T	0.0045T
112	Cam hub support & cam bearing (diameter)	0.008L	0.003L	0.005L
113	Cam hub (end clearance)	0.016	0.009	0.016
114	Cam & cam drive pinion (backlash)	0.020	0.006	0.014
115	Accessory drive shaft & bushing (diameter)	0.008L	0.0025L	0.0045L
116	Oil scavenge pump drive gear & oil scavenge pump drive shaft (diameter)	0.0025L	0.0005L	0.0017L
117	Accessory drive idler cranking motor & accessory drive gears (backlash)	0.020	0.004	0.012
118	Accessory drive idler gear (end clearance)	0.030	0.011	0.021
119	Accessory drive idler gear bushing & diffuser section (diameter)	—	0.001T	0.003T
120	Accessory drive idler gear & bushing (diameter)	0.006L	0.0025L	0.0045L
121	Accessory drive shaft bushing & crankcase rear section (diameter)	0.003L	0.000	0.002L
122	Accessory drive shaft & rear bushing (diameter)	0.006L	0.0025L	0.0045L
123	Accessory drive shaft rear bushing & crankcase rear section (diameter)	—	0.001T	0.003T
124	Magneto shaft (end clearance)	0.035	0.012	0.035
125	Accessory drive shaft bevel gear & accessory drive gear (backlash)	0.020	0.004	0.012
126	Tachometer drive gear sleeve & tachometer shaft bushing (diameter)	—	0.0005L	0.0035L
127	Tachometer, three-way acc drive shaft & accessory drive gear (diameter)	0.005L	0.001L	0.003L
128	Accessory drive gear, tachometer & three-way acc drive shaft adapter (diameter)	0.005L	0.0015L	0.0035L
129	Tachometer drive gear & driveshaft gear (backlash)	0.020	0.004	0.012
130	Tachometer drive gear & sleeve (diameter)	—	0.0005T	0.0035T
131	Tachometer drive gear & housing (end clearance)	—	0.002	0.052
132	Rear C'case, tachometer, & three-way accessory drive shaft adapter (large diameter)	—	0.001L	0.005L
133	Fuel pump adapter bushing & fuel pump drive gear (diameter)	0.006L	0.002L	0.004L
134	Rear C'case, tachometer, & three-way accessory drive shaft adapter (small diameter)	—	0.000	0.002L
135	C'case rear section & mag shaft oil seal retainer ring (diameter)	—	0.001T	0.004T
136	Fuel pump dr gear & vac pump dr shaft (backlash)	0.020	0.004	0.012

R975-C1 ENGINE (CONTINENTAL)

	POINT OF CLEARANCE	Replace Beyond	Min	Reft to Max
137	Fuel pump adapter & bushing (diameter)	—	0.0025T	0.0045T
138	Accessory drive shaft bushing & diffuser section (diameter)	—	0.001T	0.003T
139	C'case front section & oil scavenge pump housing (diameter)	—	0.000	0.002L
140	C'shaft and front c'shaft gear (diameter)	—	0.0005L	0.002L
141	Oil scavenge pump idler gear shaft & oil scavenge pump housing (diameter) . .	—	0.0005L	0.0015L
142	Oil scavenge pump idler shaft & pump idler gear (diameter)	0.003L	0.0005L	0.0015L
143	Oil scavenge pump hsg & pump idler gear (end clearance)	0.006	0.002	0.006
144	Oil scavenge pump idler gear shaft & oil scav pump cover (diameter)	—	0.001T	0.003T
145	Oil scav pump hsg & oil scav pump cover (diameter)	—	0.010L	0.030L
146	Oil scav pump housing & oil scav pump drive shaft (diameter)	0.0035L	0.001L	0.0025L
147	Oil scav pump cover & oil scav pump drive shaft	0.0035L	0.001L	0.0025L
148	Oil scav pump hsg & oil scav pump drive shaft (end clearance)	0.006	0.002	0.006
149	Oil scav pump hsg & oil scav pump dr shaft (side clearance)	0.010	0.004	0.010
150	Oil scav pump hsg & pump idler gear (side clearance)	0.010	0.005	0.0095
151	Oil scav pump cover & oil scav pump dr gear (diameter)	0.005L	0.001L	0.0025L
152	Oil scav pump dr shaft & pump idler gear (backlash)	0.014	0.002	0.006
153	Oil scav pump dr gear & c'shaft gear (backlash)	0.020	0.004	0.012
154	Oil sump strainer spring compressed to 1.0 in. height	1.25 lb	1.45 lb	—
155	Allowable run-out of crankshaft between threads and splines at forward end when supported at front main bearing and rear main bearing	(Maximum reading)	0.004	full indicator reading
156	Spine side clearance—movement of hub on crankshaft measured at 15 in. radius from center of crankshaft	0.050	—	0.040
157	Generator idler gear & cranking motor (backlash)	0.020	0.004	0.012
158	Generator idler gear bushing & shaft (diameter)	0.005L	0.001L	0.003L
159	Generator idler gear & bushing (diameter)	—	0.0005T	0.0035T
160	Generator idler gear (end clearance) . .	0.035	0.003	0.023
161	Generator drive gear support & bushing (diameter)	—	0.0015T	0.0035T
162	Generator drive gear & bushing (diameter)	0.007L	0.0025L	0.0055L
163	Generator drive gear & generator drive gear support (end clearance)	—	0.006	0.020

**ORDNANCE MAINTENANCE — 9-CYLINDER, RADIAL, GASOLINE ENGINE
(CONTINENTAL MODEL R975-C1)**

	POINT OF CLEARANCE	Replace Beyond	Refit to	
			Min	Max
164	Generator intermediate gear & gen idler gear (backlash)	0.020	0.004	0.012
165	Generator drive intermediate gear & gen dr support (end clearance).....	0.045	0.006	0.030
166	Generator intermediate gear support & bshg (diameter)	—	0.001T	0.003T
167	Gen dr intermediate gear & gen intermediate gear support bushing (diameter)	0.006L	0.0015L	0.0045L
168	Gen dr gear & gen dr interm gear (backlash)	0.020	0.004	0.012
169	Gen dr gear support & rear crankcase..	—	0.001T	0.003L
170	Gen idler gear shaft bushing & rear c'case	—	0.001T	0.003T
171	Gen idler gear shaft & rear case.....	—	0.000	0.002L
172	Generator idler gear shaft & bushing (diameter)	0.005L	0.001L	0.003L
173	Select knuckle pin locks to obtain a light tapping fit when assembled between knuckle pins	—	—	—
174	Tach & three-way accessory drive adapter cover & bushing (diameter).....	—	0.0005T	0.0025T
175	Tach & three-way accessory drive adapter and cover (diameter)	—	0.0005L	0.0025L
176	Tach & three-way accessory drive shaft & adapter cover bushing (diameter) ..	0.004L	0.0005L	0.0025L
177	Tach & three-way accessory drive shaft & three-way accessory drive gear (backlash)	0.020	0.004	0.012
178	Three-way accessory drive gear & bushing (diameter)	0.005L	0.001L	0.003L
179	Three-way accessory drive gear bushing & housing (diameter).....	—	0.0015T	0.0035T
180	Vac pump drive shaft adapter & bushing (diameter)	—	0.0035T	0.0055T
181	Vac pump dr shaft & adapter bushing (diameter)	0.005L	0.0016L	0.0036L
182	Vac pump dr shaft & collar (diameter)	—	0.0005T	0.0025T
183	Vac pump dr shaft adapter & accessory drive housing (diameter).....	—	0.0005L	0.0025L
184	Fuel pump drive gear thrust plug spring compressed to 0.56 in. height.....	8 lb	8.9 lb	9.1 lb
185	Fuel pump drive gear & thrust plug retainer (diameter)	0.003L	0.0005L	0.0015L
186	Rear c'case & three-way accessory drive housing (diameter)	0.005L	0.001L	0.003L
187	Fuel pump adapter & three-way accessory drive housing (diameter).....	—	0.0005L	0.0025L
188	Cylinder barrel bore (taper choke in upper) 4 5/16 in. of bore.....	0.005	0.008	0.010
189	Cylinder barrel bore (out of round)..	0.002	—	0.002
190	Cylinder barrel bore (diameter at flange end)	5.008	5.001	5.003

Figure 157 - Table of Limits Chart I

RA PD 309905

R975-C1 ENGINE (CONTINENTAL)

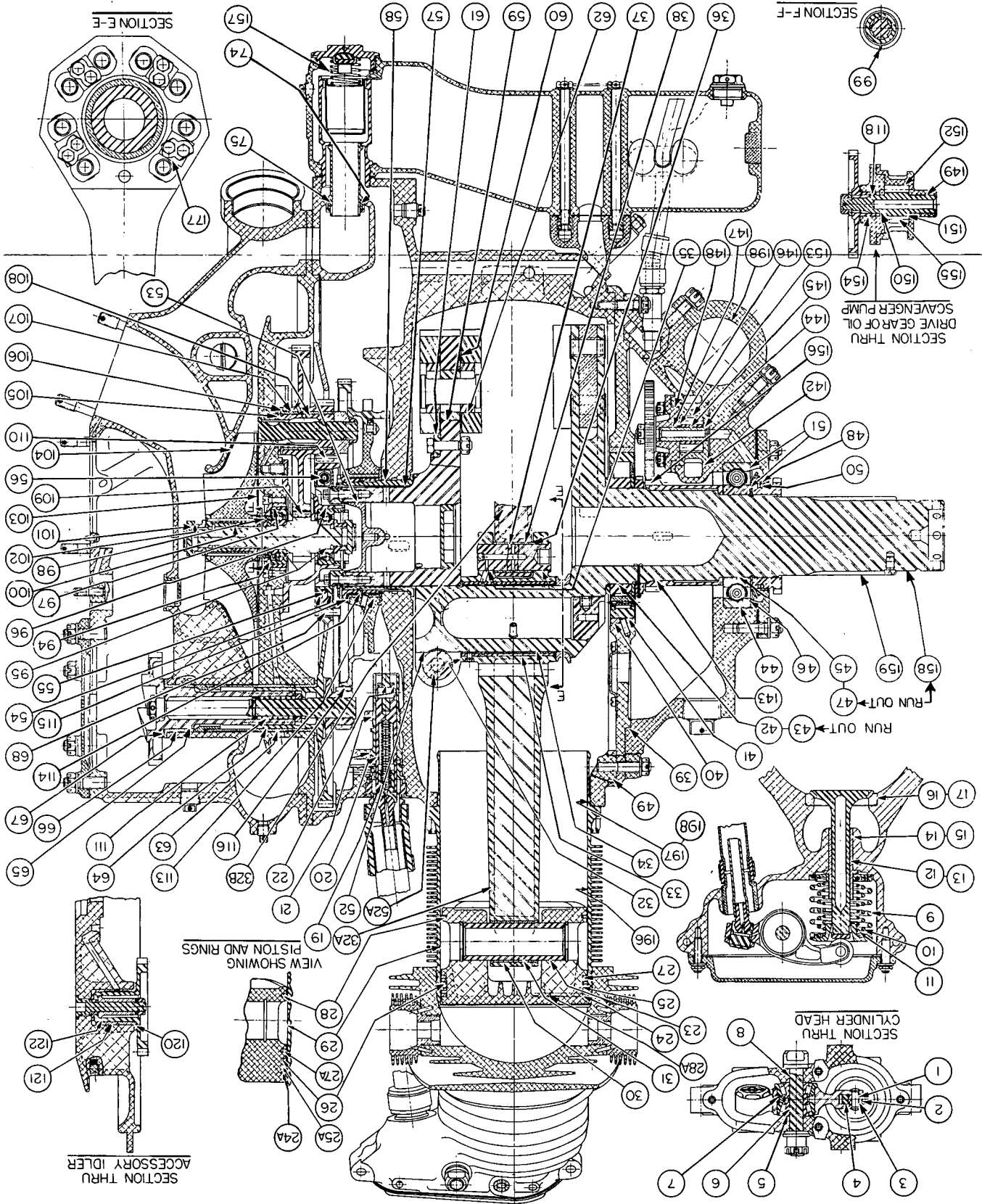

ORDNANCE MAINTENANCE -- 9-CYLINDER, RADIAL, GASOLINE ENGINE (CONTINENTAL MODEL R975-C1)

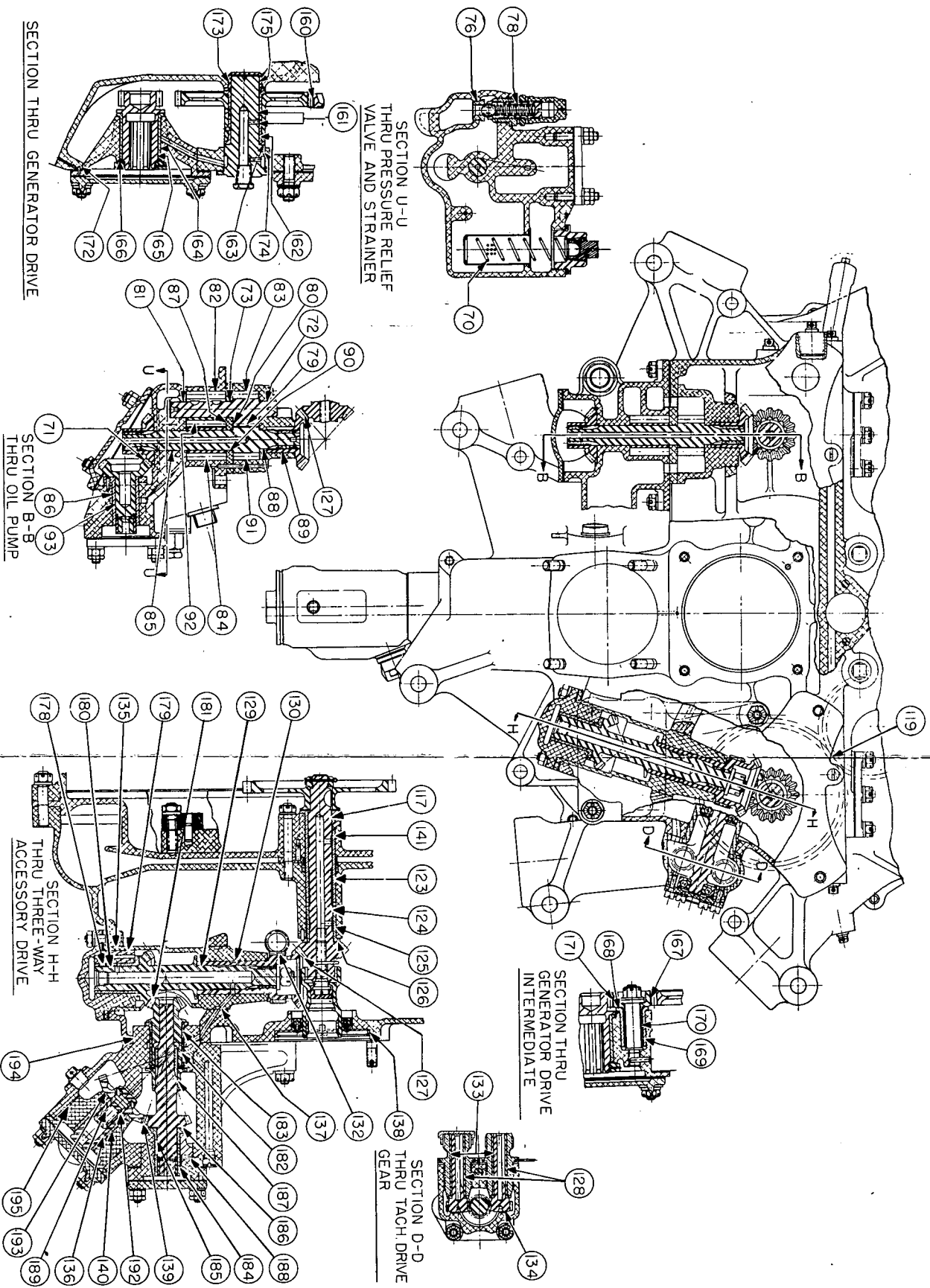

Figure 158 -- Table of Limits Chart II

RA PD 309907

R975-C1 ENGINE (CONTINENTAL)

b. Tightening and Installation Torque Values.

Cowl bracket nuts	80-85 in.-lb
Cranking motor retaining nuts.....	225-250 in.-lb
Crankshaft thrust bearing nut.....	425-450 ft.-lb
Cylinder base hold-down nuts.....	400-425 in.-lb
Cylinder exhaust elbow nuts.....	225-250 in.-lb
Engine support beam (banjo) nuts.....	400-425 in.-lb
Exhaust manifold nuts	175-200 in.-lb
Front cover hold-down nuts	225-250 in.-lb
Front to main section nuts.....	175-200 in.-lb
Intake pipe packing nuts	450-500 in.-lb
Oil sump drain plug	600-700 in.-lb
Push rod housing adapter	700-750 in.-lb
Rocker arm adjusting screw lock nut.....	600-650 in.-lb
Rocker box cover nuts	80-90 in.-lb
Rocker hub bolt nuts	250-325 in.-lb
Spark plugs	450-480 in.-lb
Studs, installation torque	
$\frac{1}{4}$ —28 Thread	50-70 in.-lb
$\frac{5}{16}$ —24 Thread	100-150 in.-lb
$\frac{3}{8}$ —24 Thread	200-275 in.-lb
$\frac{7}{16}$ —20 Thread	300-425 in.-lb
$\frac{1}{2}$ —20 Thread	500-700 in.-lb
$\frac{9}{16}$ —18 Thread	750-975 in.-lb
$\frac{5}{8}$ —18 Thread	1100-1400 in.-lb
Cap Screws, tightening torque	
$\frac{1}{4}$ —28 Thread	80-85 in.-lb
$\frac{5}{16}$ —24 Thread	160-175 in.-lb
$\frac{3}{8}$ —24 Thread	225-250 in.-lb
$\frac{7}{16}$ —20 Thread	350-375 in.-lb
$\frac{1}{2}$ —20 Thread	550-600 in.-lb
$\frac{9}{16}$ —18 Thread	825-875 in.-lb
$\frac{5}{8}$ —18 Thread.....	1125-1200 in.-lb

ORDNANCE MAINTENANCE — 9-CYLINDER, RADIAL, GASOLINE ENGINE
(CONTINENTAL MODEL R975-C1)

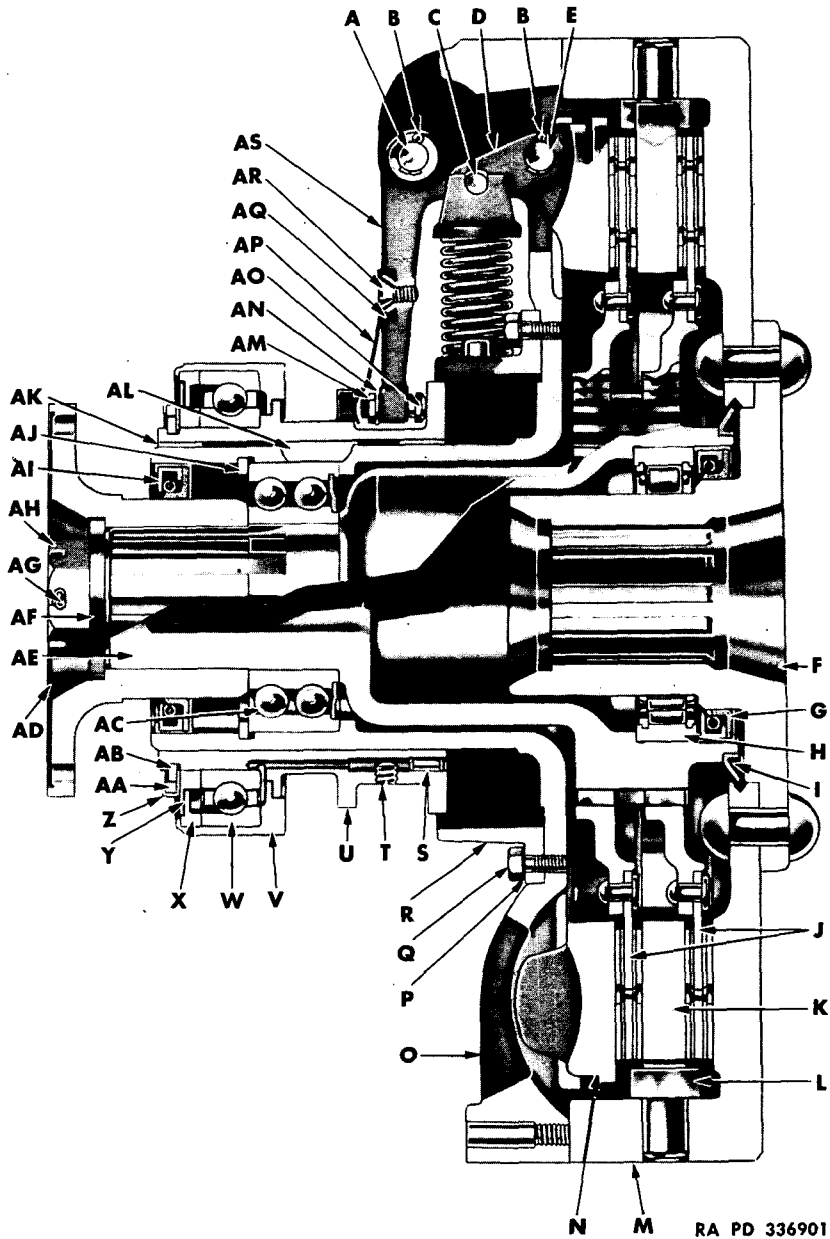

Figure 159 — Clutch Assembly — Sectional View

CLUTCH

- | | |
|---|---|
| A —RELEASE LEVER TO FLYWHEEL RING PIN | X —INNER SEAL |
| B —COTTER PIN | Y —OUTER SEAL |
| C —LINK PIN | Z —RETAINER |
| D —LINK | AA —LOCK RING |
| E —PRESSURE PLATE TO LINK PIN | AB —SNAP RING |
| F —FLYWHEEL HUB | AC —SPINDLE BALL BEARING |
| G —SPINDLE OIL RETAINER (LARGE) | AD —SPINDLE FLANGE |
| H —SPINDLE ROLLER BEARING | AE —SPINDLE |
| I —OIL SLINGER | AF —SPINDLE NUT WASHER |
| J —DRIVEN DISK ASSEMBLY | AG —COTTER PIN |
| K —DRIVING PLATE | AH —SPINDLE NUT |
| L —DRIVING PLATE DRIVING PIN | AI —SPINDLE OIL RETAINER (SMALL) |
| M —FLYWHEEL | AJ —LOCK RING |
| N —PRESSURE PLATE | AK —OIL WICK |
| O —FLYWHEEL RING | AL —SLEEVE KEY |
| P —PRESSURE SPRING CARRIER LOCK WASHER | AM —ADJUSTING SCREW LOCK NUT |
| Q —PRESSURE SPRING CARRIER CAP SCREW | AN —ADJUSTING SCREW LOCK WASHER |
| R —PRESSURE SPRING CARRIER | AO —ADJUSTING SCREW |
| S —PIN | AP —RELEASE LEVER SPRING |
| T —PIPE PLUG | AQ —RELEASE LEVER SPRING SCREW LOCK WASHER |
| U —SLEEVE | AR —RELEASE LEVER SPRING SCREW |
| V —BEARING HOUSING | AS —RELEASE LEVER |
| W —BEARING | |

RA PD 336901B

Legend for Figure 159 — Clutch Assembly — Sectional View

ORDNANCE MAINTENANCE — 9-CYLINDER, RADIAL, GASOLINE ENGINE
(CONTINENTAL MODEL R975-C1)

CHAPTER 3

CLUTCH

Section I

DESCRIPTION AND DATA

39. DESCRIPTION (fig. 159 and 160).

a. The clutch is of the dry, ventilated, two-plate type, having two driven members. It is mounted inside a recessed flywheel. The clutch assembly consists of the flywheel, spindle, spindle flange, two driven disks (one inner and one outer), a center or driving plate, a release sleeve with a coaxial throw-out bearing, and a flywheel ring assembly. The flywheel ring assembly includes the clutch release levers and linkage attached to the master pressure plate, and the pressure springs attached to the spring carrier. The clutch facings are riveted to both sides of the clutch driven disks. Plates separating adjusting screws and spring-loaded separator pins are used to assist in separating the clutch driving plate from the clutch driven disks.

b. For removal, installation, and adjustment of clutch, refer to pertinent 100-series operators' manuals.

40. TABULATED DATA AND SPECIFICATIONS.

a. Clutch Assembly.

Make.....	Lipe-Rollway and Rockford Drilling Machine Co.
Type	Multiple plate, dry
Weight	Approximately 309 lb
O.D. of flywheel.....	19.495 in.
O.D. of facing	16 in.
I.D. of facing	11½ in.
Width of facing	2¼ in.
Thickness of facing	5/32 in.
Number of pressure springs.....	6
Free height of springs.....	Approximately 27/8 in.
Assembled height of spring (at 460 — 480-lb load)	23/16 in.

CLUTCH

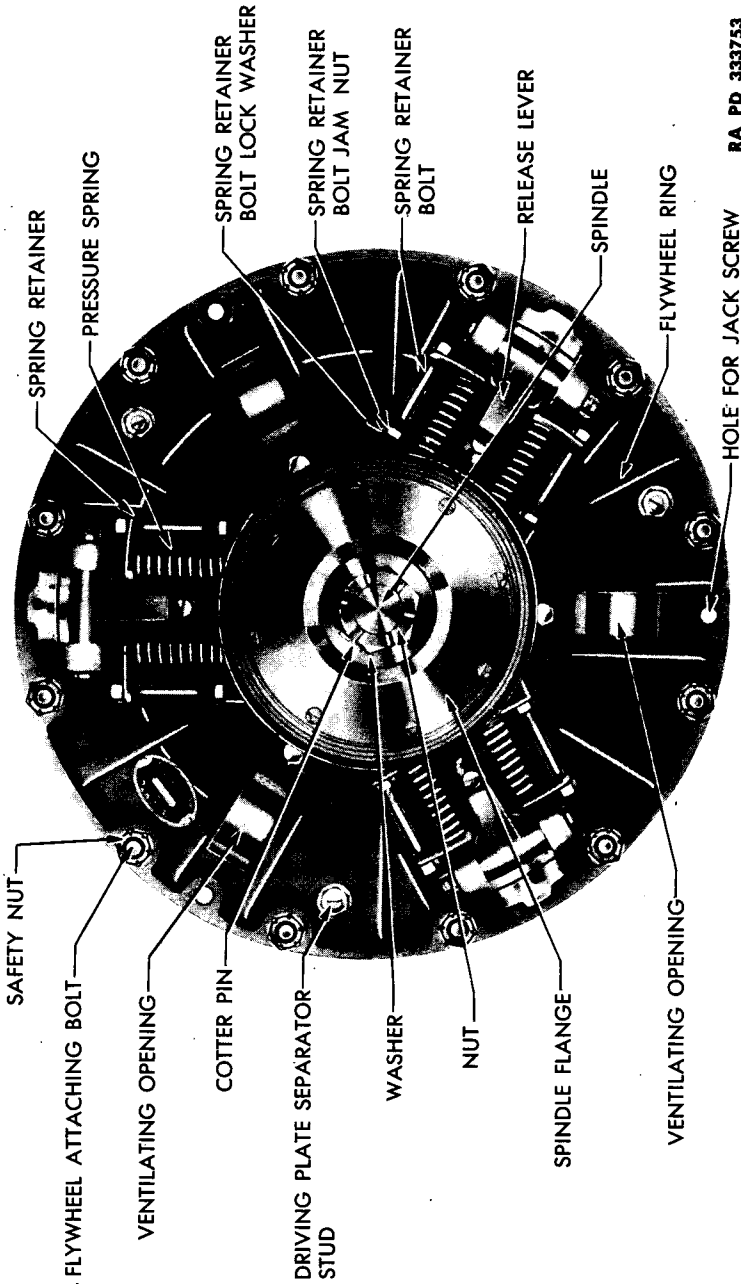

Figure 160 — Clutch Assembly—Front End View

RA PD 333753

CLUTCH

- | | | |
|-----------------------------------|--|---|
| A —COTTER PIN | W —INNER DRIVEN DISK | AQ —RELEASE LEVER TO LINK PIN |
| B —WASHER | X —SPINDLE | AR —LINK |
| C —SNAP RING | Y —RETAINER | AS —LEVER |
| D —RETAINER | Z —SLINGER | AT —FLYWHEEL RING |
| E —CASE W/BEARING ASS'Y | AA —FRONT CONE | AU —KEY |
| F —RELEASE SLEEVE | AB —FLYWHEEL | AV —RELEASE LEVER TO FLYWHEEL RING PIN |
| G —RETAINER | AC —FAN | AW —COTTER PIN |
| H —LOCK RING | AD —REAR CONE | AX —STUD |
| I —BEARING | AE —FLYWHEEL RING BOLT | AY —WASHER |
| J —SCREW | AF —SCREW | AZ —NUT |
| K —WASHER | AG —SEPARATOR PIN SPRING | BA —PRESSURE SPRING |
| L —PRESSURE SPRING CARRIER | AH —SEPARATOR PIN SPRING SPACER | BB —PRESSURE SPRING RETAINER |
| M —WICK | AI —DRIVING PLATE SEPARATOR PIN | BC —JAM NUT |
| N —SCREW | AJ —COTTER PIN | BD —WASHER |
| O —WASHER | AK —WASHER | BE —BOLT |
| P —SPRING | AL —RETAINER PIN | BF —SEAL |
| Q —NUT | AM —FRONT CONE NUT | BG —LOCK RING |
| R —WASHER | AN —BEARING | BH —SPINDLE FLANGE |
| S —SCREW | AO —COTTER PIN | BI —SPINDLE FLANGE NUT |
| T —PRESSURE PLATE | AP —PRESSURE PLATE TO LINK PIN | |
| U —OUTER DRIVEN DISK | | |
| V —DRIVING PLATE | | |

RA PD 3146498

Legend for Figure 161 — Clutch, Flywheel, and Fan Disassembled

**ORDNANCE MAINTENANCE — 9-CYLINDER, RADIAL, GASOLINE ENGINE
(CONTINENTAL MODEL R975-C1)****Section II****REMOVAL, DISASSEMBLY, CLEANING, INSPECTION,
REPAIR, AND ASSEMBLY****41. DISASSEMBLY (fig. 161).****a. Flywheel Ring and Clutch Pressure Plate Disassembly.**

(1) **REMOVE MASTER CLUTCH RELEASE LEVER SPRINGS** (fig. 159). Cover bench with clean rags to keep surface of pressure plate free from dirt. Place pressure plate and flywheel ring assembly on bench (with pressure plate down), and remove screws which secure springs to three release levers.

(2) **REMOVE CLUTCH SPINDLE FRONT BEARING** (fig. 162). Remove clutch spindle front bearing lock ring by prying one end of lock ring out of the groove in the clutch flywheel ring and pulling lock ring out of flywheel ring. Remove clutch spindle front bearing with puller (41-P-2892).

(3) **REMOVE RELEASE LEVER TO FLYWHEEL RING PINS.** Mark one of the clutch release levers with prick punch. Mark clutch pressure spring retainer and clutch spring carrier, at same locations, with same identifying mark. Mark the other two release levers, clutch pressure spring retainers, and spring carriers for identification purposes. Hold each clutch pressure spring retainer bolt with wrench, and loosen each jam nut. Back off each jam nut to the end of the bolt threads. Tighten each pair of pressure spring retainer bolts evenly, as tightly as possible, to compress the pressure springs. Remove the cotter pin from each release lever to flywheel ring pin and drive each pin out. *NOTE: These pins are serrated near head of pin and will be difficult to drive out until serrated sections are clear.*

(4) **REMOVE CLUTCH RELEASE SLEEVE AND BEARING ASSEMBLY.** Slide sleeve assembly from flywheel ring hub.

(5) **SEPARATE PRESSURE PLATE FROM FLYWHEEL RING.** Raise clutch flywheel ring, and place two wood blocks under ring. Pry clutch release lever to link pins away from the pressure spring retainer (fig. 163). Work clutch release levers down through the clutch flywheel ring, allowing pressure plate to drop (fig. 164).

(6) **REMOVE RELEASE LEVERS FROM PRESSURE PLATE.** Mark clutch pressure plate with prick punch marks to correspond with marks on each release lever. Drive out the clutch release lever to link pins. Remove release lever from the pressure plate (fig. 165).

(7) **REMOVE CLUTCH PRESSURE SPRING CARRIER.** Remove the six clutch pressure spring carrier cap screws (fig. 166). Mark master

CLUTCH

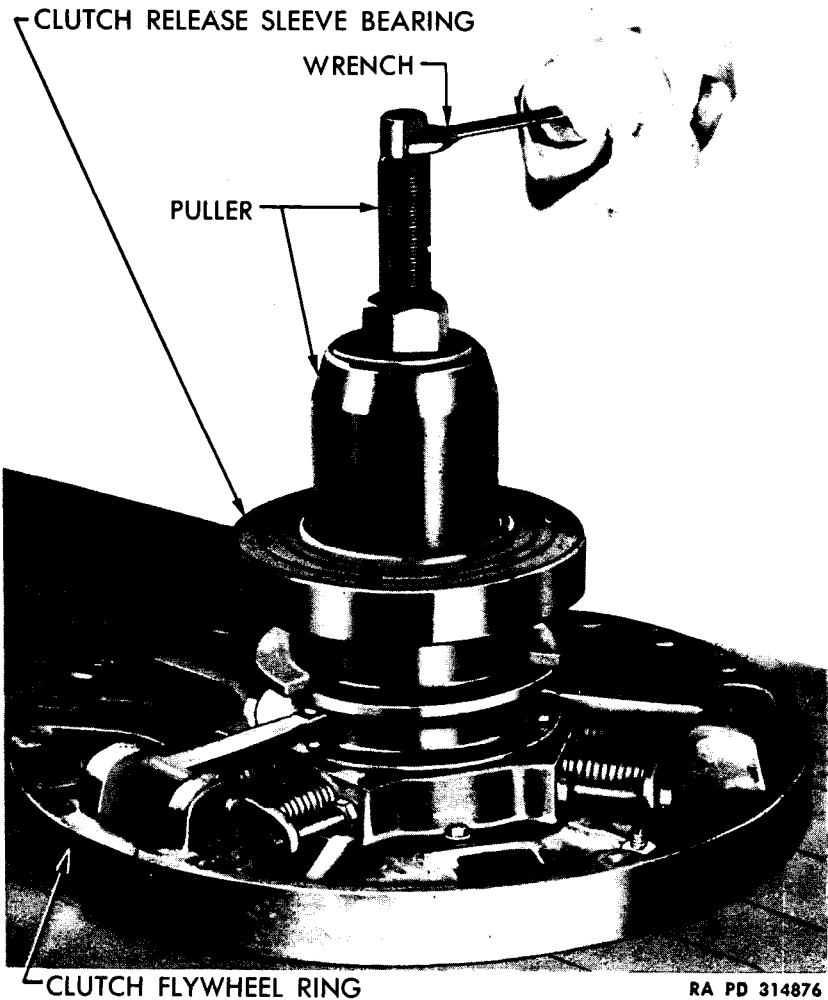

RA PD 314876

Figure 162 – Removing Clutch Spindle Front Bearing, Using Puller (41-P-2892)

clutch spring retainers with prick punch for identification when re-assembling, and remove carrier (fig. 167).

(8) **REMOVE CLUTCH PRESSURE SPRING RETAINERS** (fig. 168). Mark clutch pressure spring carrier with prick punch for identification. Loosen clutch pressure spring retainer bolts evenly. Remove bolts, retainers, springs, jam nuts, and lock washers.

(9) **REMOVE CLUTCH PRESSURE PLATE TO SPRING RETAINER LINK.** Remove cotter pins from clutch pressure plate to spring retainer link pins. Remove pins and links (fig. 169).

**ORDNANCE MAINTENANCE — 9-CYLINDER, RADIAL, GASOLINE ENGINE
(CONTINENTAL MODEL R975-C1)**

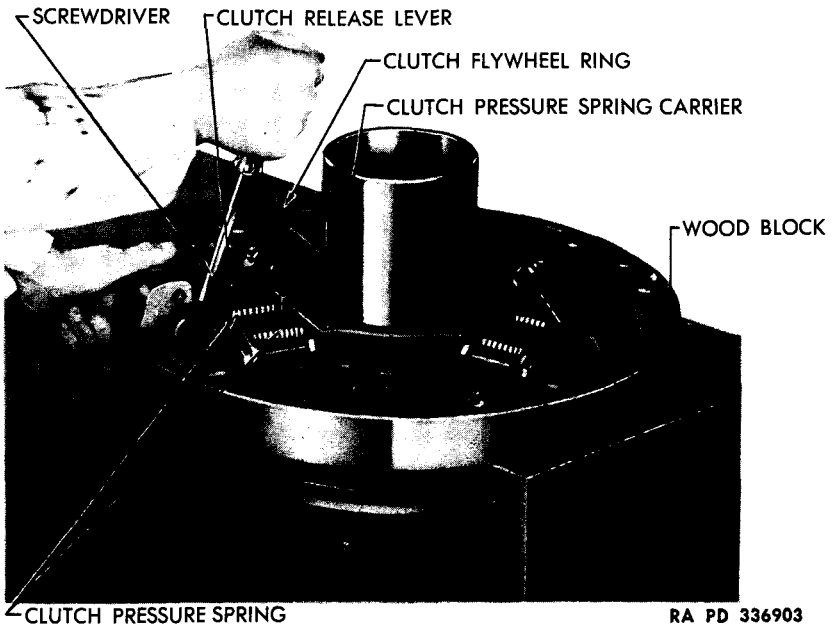

Figure 163 — Separating Pressure Plate From Flywheel Ring

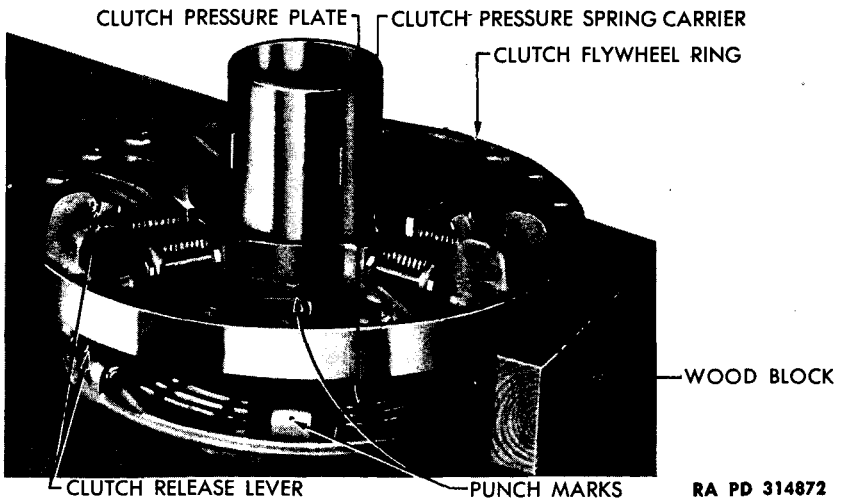
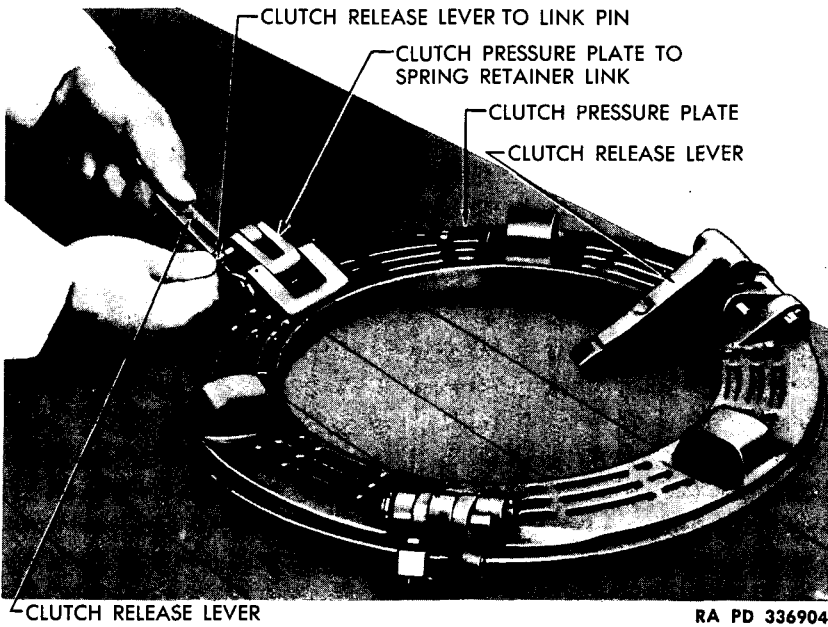

Figure 164 — Pressure Plate Removed From Flywheel Ring

b. Remove Clutch Release Bearing.

(1) REMOVE CLUTCH RELEASE BEARING FROM SLEEVE. Bend up eight tabs on the clutch release sleeve bearing retainer. With

CLUTCH



RA PD 336904

Figure 165 — Removing Release Lever From Pressure Plate

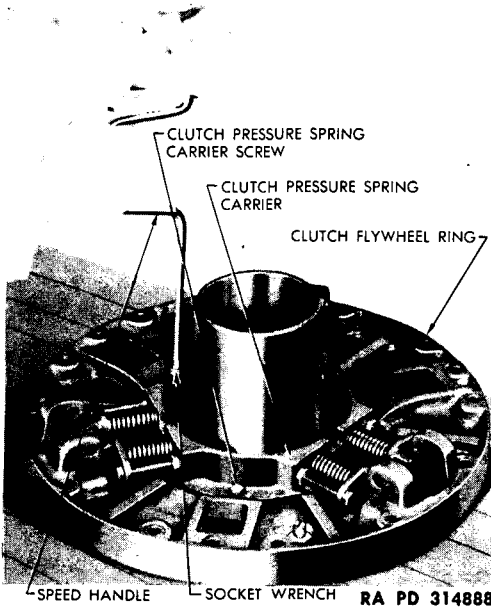

RA PD 314888

Figure 166 — Removing Pressure Spring Carrier Cap Screws

**ORDNANCE MAINTENANCE — 9-CYLINDER, RADIAL, GASOLINE ENGINE
(CONTINENTAL MODEL R975-C1)**

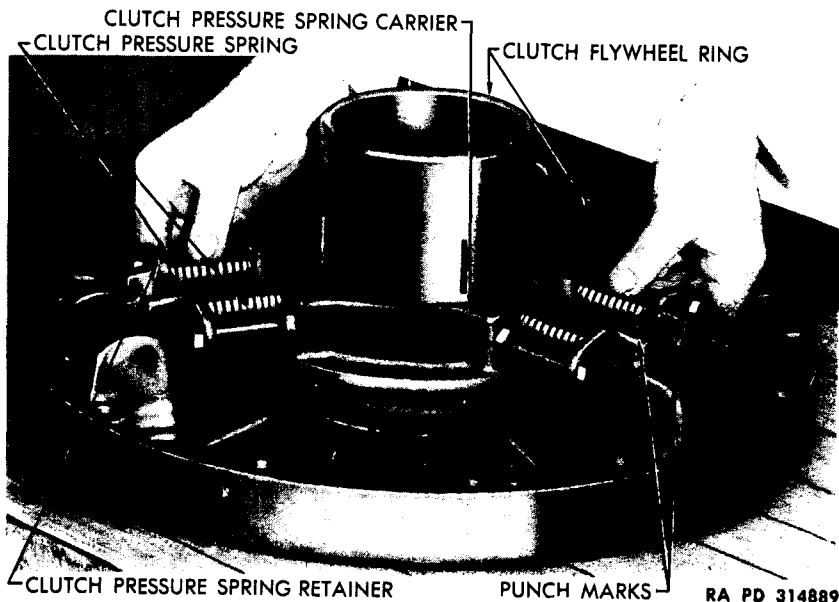

Figure 167 — Removing Pressure Spring Carrier

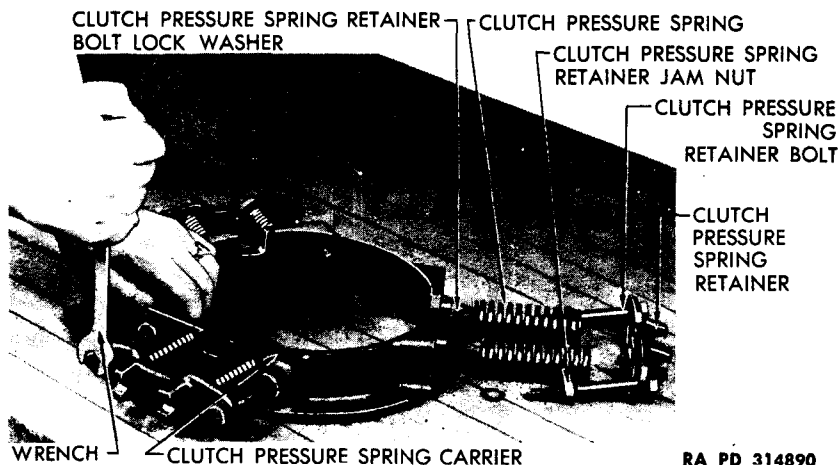

Figure 168 — Removing Clutch Pressure Spring Retainers

fingers, remove release bearing lock ring from over the snap ring. Pry up one end of the snap ring with a screwdriver, and remove snap ring from clutch release sleeve. With fingers, remove release sleeve bearing retainer and the inner seal. Place the base of removing tool (41-P-2906-75) in a vise (fig. 170). Slide the clutch release

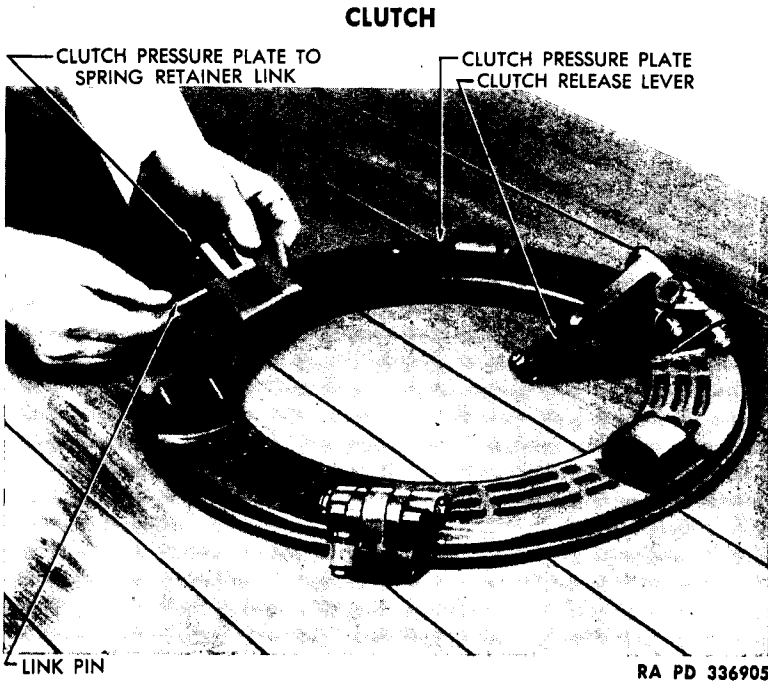

Figure 169 – Removing Pressure Plate to Release Lever Link

sleeve and bearing assembly over the tubular part of tool, aligning the two keyways in the sleeve with the two keys on the tool. Place the round plate on the sleeve, and assemble the puller of the tool in position with the $\frac{7}{16}$ -inch diameter ball bearing resting in the depression in the plate and the recess in the puller screw over the ball bearing. Hold the puller screw steady with an open-end wrench, and turn the puller clockwise to remove bearing (fig. 170).

c. Disassemble Spindle (fig. 161).

(1) **REMOVE CLUTCH SPINDLE OIL SLINGER.** If oil slinger is damaged, remove it by placing spindle in vise. Drive oil slinger off large end of the spindle.

(2) **REMOVE CLUTCH SPINDLE REAR BEARING AND OIL RETAINER.** Place bearing puller in position with the hooks of puller behind the outer race of the bearing. Pull rear bearing and oil retainer out of spindle.

42. CLEANING.

a. Wash all parts thoroughly in dry-cleaning solvent to remove dirt and grease, and other foreign matter. Dry with compressed air. Coat parts with light engine oil to prevent rusting.

ORDNANCE MAINTENANCE — 9-CYLINDER, RADIAL, GASOLINE ENGINE
(CONTINENTAL MODEL R975-C1)

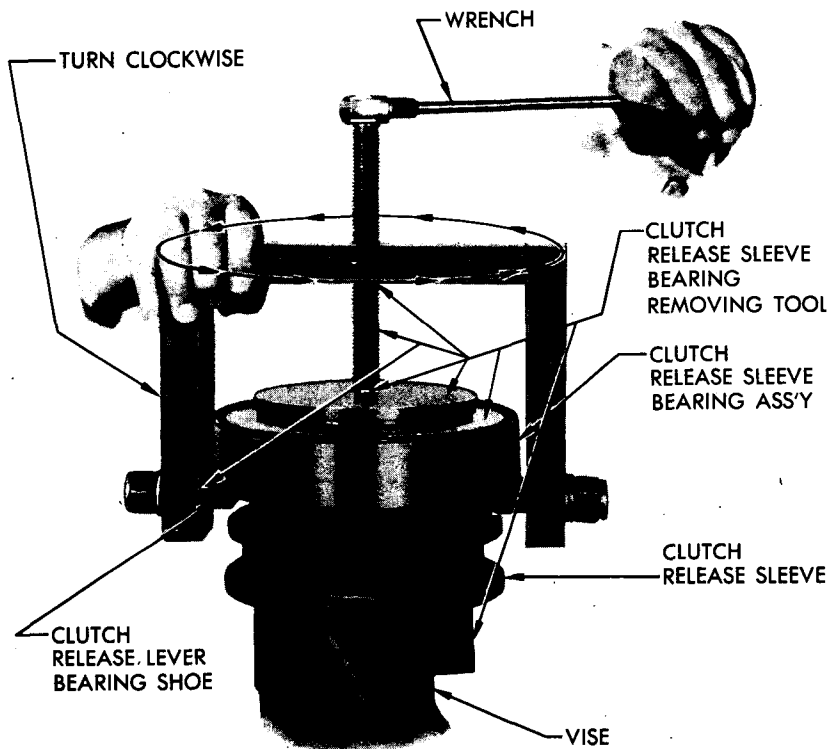

RA PD 314891

Figure 170 — Removing Clutch Release Sleeve Bearing, Using Puller (41-P-2906-75)

43. INSPECTION AND REPAIR.

a. **Inspect Flywheel Ring.** Give flywheel ring and all other steel parts a magnaflux inspection for cracks. Inspect surface of ring for cracks. Replace cracked ring. Inspect all threaded openings for damage to threads. Inspect release sleeve surface for any nicks or irregularities which will restrict travel of sleeve. Inspect clutch release sleeve keys and keyways in sleeve for damage. Inspect release lever to flywheel ring pins for wear. Inspect openings for pins in flywheel ring for any indication of scores. Inspect bearing bore and oil retainer bore in ring for scores or other damage. Inspect spindle front bearing for roughness in races and any irregularities on exterior of bearing. Replace unserviceable parts.

b. **Inspect Pressure Spring Carrier.** Inspect carrier carefully for cracks. Inspect threaded openings, to be sure threads are not damaged. Test pressure of springs by compressing to $2\frac{3}{16}$ inch.

CLUTCH

Pressure at this height should be from 460 to 480 pounds. Inspect the three clutch spring retainers for cracks or any indication of failure. Inspect spring retainer bolts and jam nuts for condition of threads, replacing with new parts if threads are damaged.

c. **Inspect Pressure Plate.** Inspect pressure plate carefully for cracks or any indication of failure. Inspect surface which contacts clutch facing for any nicks or irregularities which might not permit good contact with facing. Inspect release levers, links, and pins for cracks, wear, or any indication of failure. Inspect pressure plate to link pins for wear. Replace unserviceable parts.

d. **Inspect Driven Disks.** Remove all foreign matter from surfaces of driven disk facings with a fine mill file. Inspect surfaces for wear. If facings are worn to the point where rivets are worn approximately even with the surface of facing, replace facing. Remove rivets and facing. Inspect disk for cracks, and replace if necessary. Check disk for warpage. If warpage exceeds 0.015 inch, straighten disk before installing new facing. Rivet new facing to disk. If facings are not worn, check tightness of rivets. If any rivet is loose, replace facing. Inspect splined surfaces in hub of disk for scores. Replace disk if splines are damaged or scored.

e. **Inspect Driving Plate.** Inspect plate carefully for any cracks. Inspect surfaces, which contact facings, for any rough spots or irregularities which will not permit a good contact between plate and facing. Inspect condition of slots in outer periphery of plate for scores.

f. **Inspect Spindle.** Magnaflux with bearing and oil retainer removed; inspect both bores, to be sure they are free from scores. Inspect teeth on large diameter of spindle for any signs of brinelling. If brinelled to a point where movement of disks will be restricted, replace spindle. Inspect splines for nicks and, if nicked, remove with fine file. Inspect threads for damage. Inspect bearing for roughness or flat spots in races. Clean up rough or flat spots with fine stone.

44. ASSEMBLY.

a. Assemble Flywheel Ring and Clutch Pressure Plate.

(1) **ASSEMBLE CLUTCH PRESSURE SPRING CARRIER** (fig. 168). Insert two clutch pressure spring retainer bolts through the holes in one of the retainers, screw two jam nuts onto the bolts, and slide two lock washers over the bolts. Place springs in position, and screw the two bolts into one pair of holes in the clutch pressure spring carrier with the fingers. Hold each pressure spring retainer bolt, and screw the jam nuts back on the bolts until the jam nuts reach the ends of the bolt threads. Tighten the pressure spring retainer bolts evenly as much as possible, to compress the pressure springs. Repeat the above operations on the other two retainers.

**ORDNANCE MAINTENANCE — 9-CYLINDER, RADIAL, GASOLINE ENGINE
(CONTINENTAL MODEL R975-C1)**

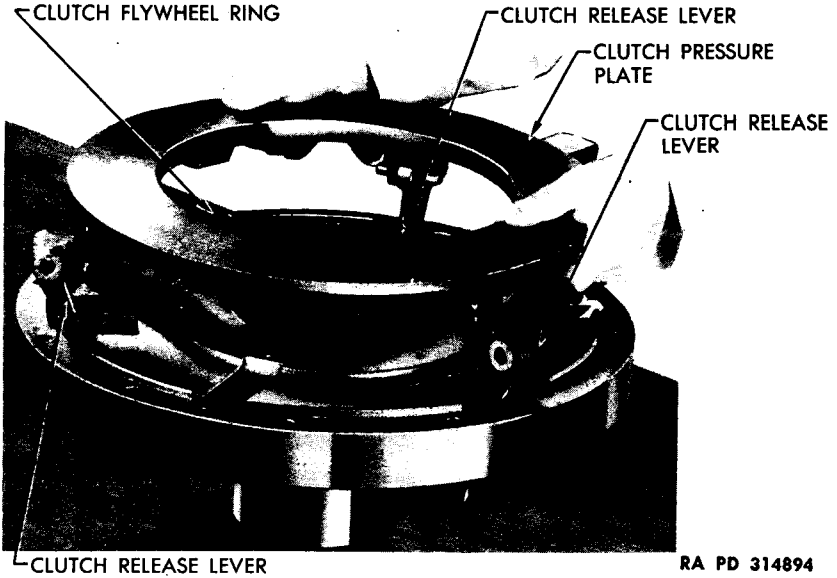

RA PD 314894

Figure 171 — Installing Pressure Plate on Flywheel Ring

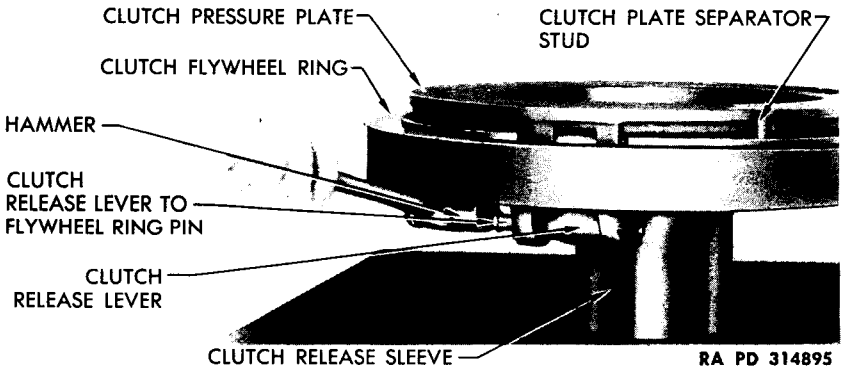

RA PD 314895

Figure 172 — Installing Release Lever to Flywheel Ring Pin

(2) **INSTALL CLUTCH PRESSURE SPRING CARRIER** (fig. 167). Place the clutch pressure spring carrier assembly in position on the clutch flywheel ring. Fasten the carrier to the ring with six cap screws and lock washers. Tighten the cap screws securely.

(3) **INSTALL CLUTCH PRESSURE PLATE TO SPRING RETAINER LINKS** (fig. 169). Place clean rags on the bench to protect the surface of the pressure plate from dirt. Aline the hole in the solid end of

CLUTCH

the link with the two holes in the pressure plate, and insert the link pin through the hole. Secure pin with cotter pins.

(4) **ATTACH CLUTCH RELEASE LEVERS TO LINKS** (fig. 165). Select the release lever that has one prick punch mark, and place it in position in the link at the location of the pressure plate that has one prick punch mark. Aline the hole in the release lever with the holes in the link, and insert the release lever to link pin through the hole. Repeat the above operation with the other two levers, selecting in each instance the lever with marks that match the marks on the pressure plate.

(5) **INSTALL PRESSURE PLATE ON FLYWHEEL RING.** Place the flywheel ring on the bench with the sleeve down. Hold the pressure plate in position, matching the prick punch marks on the clutch flywheel ring with those on the clutch release levers and pressure plate. Insert the ends of the clutch release levers through the holes in the flywheel. Insert pins through levers and holes in flywheel ring far enough to hold pressure plate to flywheel ring to permit turning assembly on bench (fig. 171).

(6) **INSTALL CLUTCH RELEASE SLEEVE BEARING.** Place clutch release sleeve on a press with the bearing end up. Place the bearing in position on the sleeve and the installing tool in position on top of the bearing. Then press the bearing into place until it seats firmly against the flange of the sleeve. Install inner seal and bearing retainer on sleeve. Install snap ring in groove in sleeve, and install lock ring. Bend the eight tabs of release bearing retainer to secure assembly.

(7) **INSTALL CLUTCH RELEASE SLEEVE.** Turn clutch flywheel ring and pressure plate assembly over on bench so that the flywheel ring is up. Aline two keyways in sleeve with the two keys on flywheel ring. Slide sleeve over hub of flywheel ring. Remove release lever to flywheel ring pins, and raise levers to allow sleeve to pass levers. Place three blocks between two rear flanges of sleeve, where levers enter, to prevent levers from slipping. Aline holes in flywheel ring and pressure plate to spring retainer links, and install the three release levers to flywheel ring pins. Always turn the pins so that the serrations on pin will seat in new location in openings. Drive pins into position with hammer, and insert cotter pins through holes in pins to secure them before adjustment is made to the lever adjusting screw.

(8) **ADJUST CLUTCH PRESSURE SPRING RETAINER BOLTS.** Loosen clutch pressure spring retainer bolts evenly until pressure of springs holds retainers on clutch release lever to link pins. Continue to loosen the bolts until distance from the underside of the bolt head to the face of the pressure spring carrier is $2\frac{3}{4}$ inches. This will allow the bolt to clear the spring retainer. Tighten the jam nuts securely.

ORDNANCE MAINTENANCE — 9-CYLINDER, RADIAL, GASOLINE ENGINE
(CONTINENTAL MODEL R975-C1)

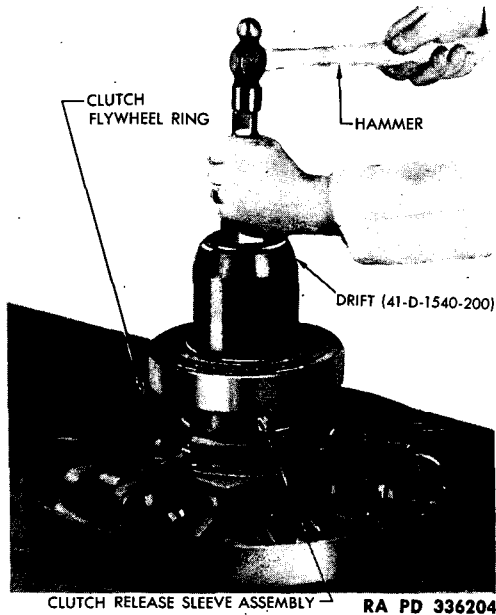

Figure 173 — Installing Spindle Front Bearing

(9) **ADJUST CLUTCH RELEASE LEVER HEIGHT.** Hold head of clutch release lever adjusting screw, and loosen the adjusting screw lock nut. Turn adjusting screw until it is in the approximate position of the screws in the other two levers, or until screw just contacts the inner flange of the clutch release sleeve. Leave lock nut loose, to permit final adjustment after assembly of flywheel ring and pressure plate to flywheel. **NOTE:** *After flywheel ring and pressure plate assembly is installed on flywheel, make final adjustment by turning adjusting screw until head of screw just contacts the inner flange of the clutch release sleeve, and secure by tightening lock nut.*

(10) **INSTALL CLUTCH RELEASE LEVER SPRINGS.** Place clutch release lever springs in position on the clutch release levers. Fasten springs in place with screws and lock washers. Tighten screws securely.

(11) **INSTALL DRIVING PLATE SEPARATOR STUDS.** Install driving plate separator studs and lock nuts. Turn nuts in with fingers a few turns to hold them in place.

b. Assemble Spindle.

(1) **INSTALL CLUTCH SPINDLE FRONT BEARING (fig. 173).** Place clutch flywheel ring on bench with hub up. Place clutch spindle front

CLUTCH

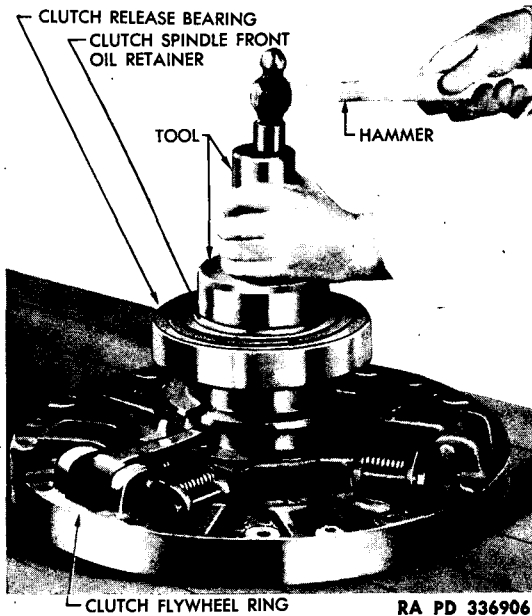

Figure 174 – Installing Spindle Front Bearing Oil Retainer, Using Drift (41-D-1540-800)

bearing in position at opening of hub. Drive bearing into sleeve with drift (41-D-1540-200) and hammer. Insert clutch spindle front bearing lock ring in hub. Force lock ring in place in groove with a screwdriver. Place a film of grease on clutch spindle front oil retainer leather. Place oil retainer in position at opening of hub, with the leather lip of the retainer away from the bearing. Drive retainer into place in sleeve with a drift and a hammer (fig. 174). Pack the clutch spindle front bearing with ball and roller bearing grease and fill the cavity between the bearing and the oil retainer three-quarters full of grease.

(2) **INSTALL CLUTCH SPINDLE REAR BEARING** (fig. 175). Place spindle in vise (equipped with brass jaws). Place clutch spindle rear bearing in position at opening in spindle. Place bearing installing tool in position with the edge of the tool applied against outer race of bearing. Drive bearing into place with hammer.

(3) **INSTALL CLUTCH SPINDLE REAR BEARING OIL RETAINER.** Place oil retainer in position at opening in spindle (with lip of seal toward bearing). Drive retainer into place with hammer and oil seal installing tool.

ORDNANCE MAINTENANCE — 9-CYLINDER, RADIAL, GASOLINE ENGINE
(CONTINENTAL MODEL R975-C1)

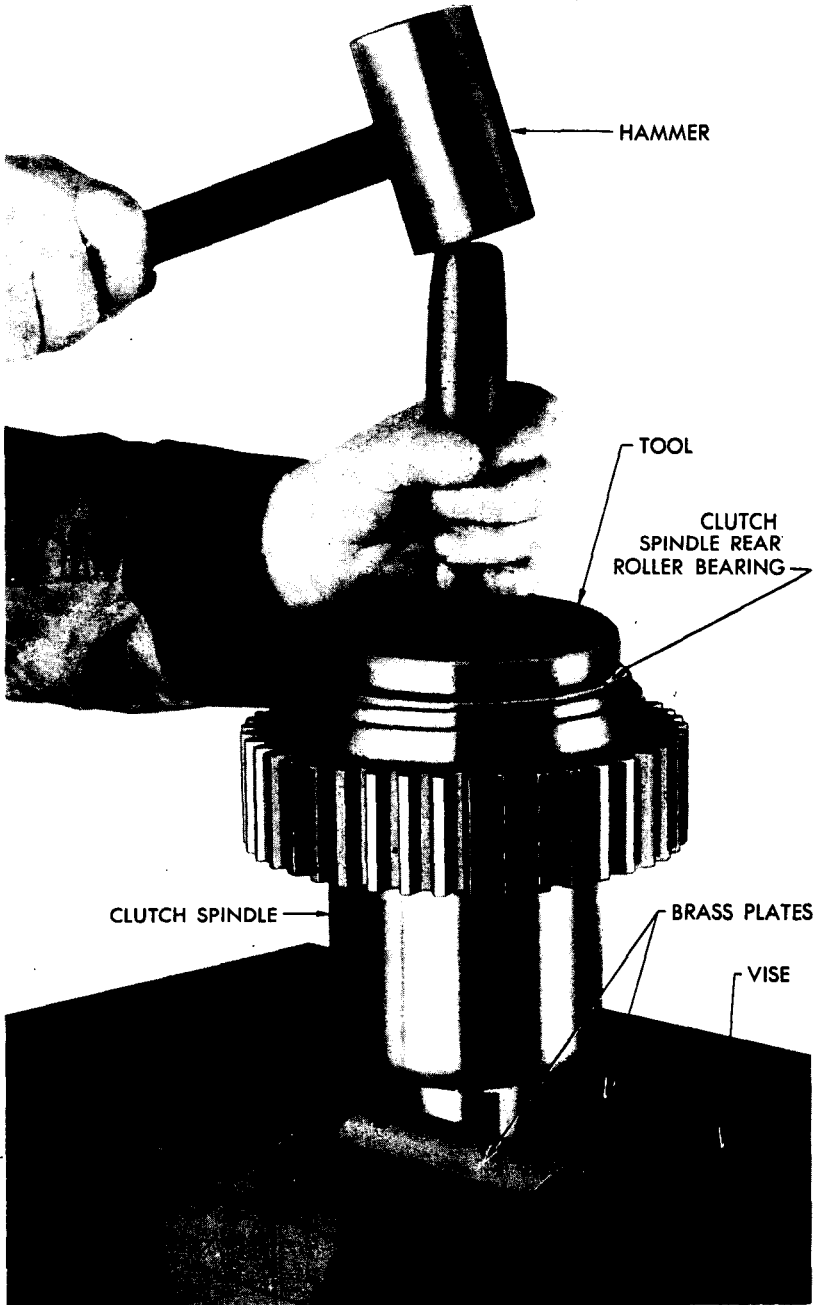

RA PD 336907
Figure 175 — Installing Spindle Rear Bearing, Using Drift
(41-D-1540-150)

CLUTCH

(4) **INSTALL CLUTCH SPINDLE OIL SLINGER.** If slinger was removed, place spindle in position on press with large end up. Place oil slinger in position on large end of spindle. Press oil slinger into position.

Section III

TABLE OF LIMITS

45. FITS AND TOLERANCES.

a. **General.** The following limits and tolerances are production standards under which new clutches are manufactured. Due to varying conditions of service, no attempt is made to list wear limits allowed before replacement of clutch parts.

b. Flywheel Ring.

	Min.	Max.
Outside diameter of front spindle bearing . . .	4.7244 in.	4.7244 in.
Diameter of front spindle bearing seat	4.7234 in.	4.7244 in.
Outside diameter of front spindle oil seal . . .	4.754 in.	4.758 in.
Diameter of front spindle oil seal seat	4.749 in.	4.751 in.
Diameter of release lever to flywheel ring pin holes	0.4995 in.	0.5005 in.
Diameter of release lever to flywheel ring pin	0.4970 in.	0.4985 in.
Outside diameter of flywheel ring hub	5.305 in.	5.307 in.
Inside diameter of release sleeve	5.312 in.	5.314 in.

c. Pressure Plate.

Diameter of link pin holes	0.4995 in.	0.5005 in.
Diameter of pressure plate to link pin	0.4970 in.	0.4985 in.

d. Pressure Spring.

Load at assembled height of $2\frac{3}{16}$ in.	460 lb	480 lb
---	--------	--------

e. Clutch Release Sleeve.

Outside diameter of sleeve hub	5.9998 in.	6.0008 in.
Inside diameter of release sleeve bearing . . .	5.9990 in.	6.0000 in.
Inside diameter of bearing inner seal	5.9990 in.	6.0000 in.

f. Driven Disk.

Inside diameter of splines	6.750 in.	6.760 in.
Backlash on splines	0.004 in.	0.006 in.
Thickness of disk and facings	0.434 in.	0.450 in.

ORDNANCE MAINTENANCE — 9-CYLINDER, RADIAL, GASOLINE ENGINE
(CONTINENTAL MODEL R975-C1)

g. Driving Plate.

	Min.	Max.
Width of slots	1.005 in.	1.008 in.
Width of driving pins	0.990 in.	0.992 in.
Thickness of plate	0.684 in.	0.687 in.

h. Spindle.

Outside diameter of front splines	2.497 in.	2.498 in.
Inside diameter of front splines	2.261 in.	2.271 in.
Inside diameter of front bearing	2.5591 in.	2.5591 in.
Diameter of front bearing seat	2.5580 in.	2.5586 in.
Outside diameter of rear bearing	5.1181 in.	5.1181 in.
Rear bearing seat diameter	5.1174 in.	5.1186 in.
Outside diameter of rear oil retainer	5.129 in.	5.133 in.
Diameter of rear oil retainer seat	5.1250 in.	5.133 in.
Inside diameter of oil slinger	5.494 in.	5.496 in.
Diameter of oil slinger seat	5.499 in.	5.502 in.

CHAPTER 4
SPECIAL TOOLS

46. SPECIAL TOOLS.

a. Special tools mentioned in this technical manual are listed below. The list is provided for information only and is not to be used as a basis of requisition. Refer to the appropriate SNL when procuring tools.

b. Tool List.

Tool	Federal Stock No.
ADAPTER, puller, front crankcase section removing (used w/universal puller)	41-A-18-50
BAR, articulating, rod knuckle pin bushing, finish bore, 0.8764-in. diameter; selective fit No. 1 . . .	41-B-19-600
BAR, articulating, rod knuckle pin bushing, finish bore, 0.8769-in. diameter; selective fit No. 2 . . .	41-B-19-610
BAR, crankshaft alining, 0.4995-in. diameter; selective fit No. 1	41-B-150-25
BAR, crankshaft alining, 0.4997-in. diameter; selective fit No. 2	41-B-150-27
BAR, crankshaft alining, 0.4999-in. diameter; selective fit No. 3	41-B-150-30
BAR, master and articulating rod, piston pin bushing, finish bore alinement checking, 1,250-in. diameter; selective fit No. 1	41-B-263-11
BAR, master rod crankshaft bearing, finished bore alinement, 2.2530-in. diameter	41-B-263-29
BAR, valve tappet guide, installing	41-B-332
BUSHING, exhaust valve guide cylinder hole (used w/41-R-493)	41-B-2032
COLLAR, cam hub bearing installing	41-C-2482-100
COMPRESSOR, piston ring, 5-in. diameter, special	41-C-2550-80
COMPRESSOR, valve spring	41-C-2559-25
CONE, accessory drive shaft, leather oil seal, installing	41-C-2562-11
DRIFT, clutch spindle bearing, inner, installing . . .	41-D-1540-150
DRIFT, clutch spindle bearing, outer, installing . . .	41-D-1540-200
DRIFT, engine clutch, oil retainer, installing	41-D-1540-800
DRIFT, piston (round fiber)	41-D-1541-75
DRIFT, cranking motor shaft cork, oil seal and spacer, removing and installing	41-D-1546-55
EYE, crankshaft and engine lifting	41-E-615
FIXTURE, accessory drive shaft bushing, diffuser section, and rear crankcase section holes, line ream	41-F-2987-210

**ORDNANCE MAINTENANCE — 9-CYLINDER, RADIAL, GASOLINE ENGINE
(CONTINENTAL MODEL R975-C1)**

Tool	Federal Stock No.
FIXTURE, boring, master and articulated rod bearing	41-F-2987-425
FIXTURE, cam hub bearing hole, peen.....	41-F-2987-500
FIXTURE, rear bearing, reconditioning.....	41-F-2994-21
Consisting of:	
1 REAMER, finish (standard 0.010-in. under)	
1 REAMER, semifinish (standard 0.010-in. under)	
1 REAMER, crankcase hole (0.004- to 0.010-in.)	
FIXTURE, timing, including disk, pointer and handle (bare engine)	41-F-2997-84
GAGE, thickness, special, 0.010-in. and 0.070-in....	41-G-412-75
INDICATOR, piston, top dead center, dial-type (with box)	41-I-73-110
PLUG, cam hub bearing, installing.....	41-P-2098-500
PLUG and COLLAR, master rod crankshaft bearing, removing and installing.....	41-P-2115-500
PLUG and COLLAR, rocker arm bearing, removing and installing	41-P-2116
PULLER, clutch front spindle bearing.....	41-P-2892
PULLER, clutch release bearing.....	41-P-2906-75
PULLER, crankcase section removing (3 per engine required)	41-P-2906-280
PULLER, crankshaft rear end plug.....	41-P-2907-100
PULLER, knuckle pin	41-P-2941-125
PULLER, leather oil seal, accessory drive.....	41-P-2951-11
PULLER, supercharger, impeller	41-P-2954-600
PUNCH, cam hub bearing pin hole peening.....	41-P-3160
PUNCH, master rod, crankshaft bearing dowel staking	41-P-3762
REAMER, carbon steel, accessory drive shaft short and long bushing hand, line ream, standard size..	41-R-390
REAMER, carbon steel, exhaust valve guide stem hole, expansion, standard.....	41-R-494
REAMER and BUSHING, cranking motor shaft and cranking motor drive gear bushing.....	41-R-2324
REMOVER and REPLACER, rear main bearing..	41-R-2373-675
ROLLERS, crankshaft alinement	41-R-2660
SCREWDRIVER, valve clearance adjusting.....	41-S-1725
SLING, engine	41-S-3832
STAND, crankshaft assembly and disassembly....	41-S-4932
STAND, master and articulating rod hole alinement checking	41-S-4977

SPECIAL TOOLS

Tool	Federal Stock No.
STAND, valve removing and installing.....	41-S-4988-77
STRIPPER and CUTTER, for high and low tension cable	41-S-6010
TOOL, impeller shaft and front nut, locking.....	41-T-3217-100
TOOL, measuring, crankshaft check, cap screw stretch	41-T-3268
TOOL, swaging, ignition wire ferrule.....	41-T-3369-10
TOOL-SET, piston pin and knuckle bushing replace- ment	41-T-3539-8
WRENCH, box, generator attaching, 1/2-in., special	41-W-636-550
WRENCH, box, oil relief valve body check nut and cap, 7/8-in. x 9/16-in. hex.....	41-W-636-620
WRENCH, crankshaft bearing lock nut, front main	41-W-871-27
WRENCH, crankshaft gear hub screw (O.D., 0.550 to 0.555 in.)	41-W-871-31
WRENCH, crankshaft thrust bearing nut.....	41-W-871-35
WRENCH, cylinder hold-down nut, 1/2-in. hex (used on Model EC-1 and EC-2).....	41-W-871-37
WRENCH, crowfoot, cranking motor attaching, 9/16-in., special	41-W-871-45
WRENCH, engine oil sump retainer.....	41-W-906-12
WRENCH, exhaust elbow to cylinder stud nut....	41-W-1471
WRENCH, idler accessory drive gear nut.....	41-W-1536
WRENCH, impeller shaft front ball bearing retainer nut	41-W-1536-250
WRENCH, intake pipe packing nut.....	41-W-1537
WRENCH, oil pump to crankcase rear section at- taching nut, 7/16-in. hex	41-W-1577-500
WRENCH, push rod housing adapter.....	41-W-1985
Consisting of:	
1 EXTENSION, wrench, crowfoot	41-E-515
1 HANDLE, wrench, crowfoot	41-H-1543-85
1 WRENCH, crowfoot, 1 1/8-in.	41-
WRENCH, push rod housing clamp screw (flexible)	41-W-1986
WRENCH, socket, valve tappet retainer nut, 1 1/8-in. hex	41-W-2964-550
WRENCH, socket, spark-plug type, 1/2-in. sq-drive, 1-in.	41-W-3328
WRENCH, tachometer housing and oil pump at- taching	41-W-3418
WRENCH, valve adjusting and clamp screw.....	41-W-3812-480

**ORDNANCE MAINTENANCE — 9-CYLINDER, RADIAL, GASOLINE ENGINE
(CONTINENTAL MODEL R975-C1)**

REFERENCES

PUBLICATIONS INDEXES.

The following publications indexes should be consulted frequently for latest changes to or revisions of the publications given in this list of references and for new publications relating to materiel covered in this manual:

- a. Introduction to Ordnance Catalog (explaining ASF Cat. SNL system) ORD 1 IOC
- b. Ordnance Publications for Supply Index (index to SNL's) ASF Cat. ORD 2 OPSI
- c. Index to Ordnance Publications (listing FM's, TM's, TC's and TB's of interest to ordnance personnel, OPSR's, MWO's, BSD, S of SR's, OSSC's, and OFSB's; and includes Alphabetical List of Major Items with Publications Pertaining Thereto) OFSB 1-1
- d. List of Publications for Training (listing MR's, MTP's, T/BA's, T/A's, FM's, TM's, and TR's concerning training) FM 21-6
- e. List of Training Films, Film Strips, and Film Bulletins (listing TF's, FS's, and FB's by serial number and subject)..... FM 21-7
- f. Military Training Aids (listing Graphic Training Aids, Models, Devices, and Displays)..... FM 21-8

STANDARD NOMENCLATURE LISTS.

- Carriage, motor, 105-mm howitzer, M7..... SNL G-128
- Carriage, motor, 155-mm gun, M12..... SNL G-158
- Carrier, cargo, M30 (T14)..... SNL G-158
- Cleaning, preserving and lubrication materials; recoil fluids, special oils, and miscellaneous related items SNL K-1
- General tools, and supplies, ordnance base automotive maintenance company (engine rebuild) SNL N-327
- Ordnance maintenance sets SNL N-21
- Soldering, brazing and welding materials, gases and related items SNL K-2
- Tank, medium, M4 (75-mm gun, dry)..... SNL G-104
Vol. 6

REFERENCES

Tank, medium, M4 (76-mm gun, wet)	SNL G-206
Tank, medium, M4 (105-mm howitzer)	SNL G-104
	Vol. 14
Tank, medium, M4A1 (75-mm gun, dry)	SNL G-104
	Vol. 11
Tank, medium, M4A1 (76-mm gun, wet)	SNL G-207
Tool-sets, motor transport	SNL N-19
Tool-sets, for ordnance service command, auto- motive shops	SNL N-30
Tools, maintenance, for repair of automotive vehicles	SNL G-27

EXPLANATORY PUBLICATIONS.

Fundamental Principles.

Automotive electricity	TM 10-580
Basic maintenance manual	TM 38-250
Electrical fundamentals	TM 1-455
Fuels, lubricants, cleaners, and preservatives . . .	TM 9-2835
Internal combustion engine, the	TM 10-570
Machinist, the	TM 10-445
Military motor vehicles	AR 850-15
Motor vehicle inspections and preventive mainte- nance service	TM 9-2810
Precautions in handling gasoline	AR 850-20
Standard military motor vehicles	TM 9-2800

Maintenance and Repair.

Cleaning, preserving, lubricating, and welding materials and similar items issued by the Ordnance Department	TM 9-850
Cold weather lubrication and service of combat vehicles and automotive materiel	OFSB 6-11
Ordnance Maintenance: Accessories for Wright F975-EC2 engine for medium tanks M3 and M4	TM 9-1750D
Ordnance Maintenance: American Bosch mag- netos MJT7A302, MJT9A304 and MJT9A306	TM 9-1750C
Ordnance Maintenance: Carburetors (Strom- berg)	TM 9-1826B
Ordnance Maintenance: Electrical equipment (Delco-Remy)	TM 9-1825A
Ordnance Maintenance: Fuel pumps	TM 9-1828A

**ORDNANCE MAINTENANCE — 9-CYLINDER, RADIAL, GASOLINE ENGINE
(CONTINENTAL MODEL R975-C1)**

Operation of Materiel.

105-mm howitzer motor carriage, M7.....	TM 9-731E
155-mm gun motor carriage M12 and cargo carrier M30 (T14)	TM 9-751
Medium tanks M4 and M4A1.....	TM 9-731A
Medium tanks M4 and M4A1 (76-mm gun and 105-mm howitzer)	TM 9-731AA

Protection of Materiel.

Camouflage	FM 5-20
Chemical decontamination, materials and equipment	TM 3-220
Decontamination of armored force vehicles....	FM 17-59
Defense against chemical attack.....	FM 21-40
Explosives and demolitions.....	FM 5-25

Storage and Shipment.

Ordnance storage and shipment chart, group G — Major items	OSSC-G
Registration of motor vehicles.....	AR 850-10
Rules governing the loading of mechanized and motorized equipment also major caliber guns, for the United States Army and Navy, on open top equipment published by Operations and Maintenance Department of Association of American Railroads.	
Storage of motor vehicle equipment.....	AR 850-18

**ORDNANCE MAINTENANCE — 9-CYLINDER, RADIAL, GASOLINE ENGINE
(CONTINENTAL MODEL R975-C1)**

C — Contd.	Page	Page	
Cam CMC 200742, valve timing....	16	repair	97
Cam CMC 202347, valve timing....	17	Cotter pins, installation.....	57, 113
Carburetor BS-NAR9D (See TM 9-1826B)		Cover, crankcase front section	
Carburetor BS-NAR9G (See TM 9-1826B)		inspection	60
Carburetor and elbow		removal	43
installation	187	repair	62
removal	18	Cowl	
Carrier, clutch pressure spring		installation	183
assembly	213	removal	26
installation	214	Crankcase	
removal	206	assembly	
Cleaners		front section	63, 165
volatile	52	main section	109, 117
water soluble	51	cleaning and inspection	
Cleaning		front section	60
clutch	211	main section	74, 76, 86
crankcase		rear section housing.....	144
front section	60	disassembly	
main section	74	front section	58
diffuser section	129	main section	63
engine		removal	45
engine	17	repair	
parts of	57	front section	62
rear section	144	main section	91, 104
general instructions	51	rear section housing.....	148
valve guides	95	Cranking motor	
Clearance values (table of limits)..	190	assembly (drive gear and shaft)..	164
Clutch		direction of rotation and ratio to crankshaft speed	8
assembly	213	inspection	131
cleaning	211	installation	
description, data, and specifica- tions	202	cranking motor	186
disassembly	206	shaft oil seals	163
inspection and repair.....	212	support bracket	187
Compression ratio	15	removal	
Conduits, flexible, removal.....	122	cranking motor	18
Conduits, magneto, assembly.....	124	drive gear and shaft.....	47
Conduits, terminal, assembly.....	124	repair	134
Connecting rod, master		replacement (drive gear bush- ing)	132, 148
assembly	112	Cranking motor DR-1108685 (See TM 9-1825A)	
inspection	83	Cranking motor EC-817 (See TM 9-1750D)	
removal	69	Crankshaft	
repair	102	assembly	
Connecting rods, articulated		crankshaft and gear.....	110
assembly	117	gear (front crankshaft).....	164
inspection of bushings and rods....	82	check alinement	114
removal	63		

INDEX

C — Contd.	Page	Description	Page
Crankshaft — Contd.			
disassembly (rear crankshaft).....	72	clutch	202
inspection		engine	8
front crankshaft	87	lubrication system	11
gear (front crankshaft).....	61	Diffuser section	
gear (rear crankshaft).....	89	assembly	
rear crankshaft	88	diffuser section	134
installation	117	to engine	163, 164
ratios of drives to crankshaft		cleaning and inspection.....	129
speed	8	description	11
removal		disassembly	125
crankshaft	67	removal	
gear (front crankshaft).....	45	diffuser section	49
repair		gear and shaft.....	47
front crankshaft	107	repair	131
gear (front crankshaft).....	62	Disassembly	
gear (rear crankshaft).....	108	clutch	206
rear crankshaft	108	crankcase	
separate		front section	58
set (magneto installation)		main section	63
Bosch magnetos	181	crankshaft (rear)	72
Scintella magnetos	179	diffuser section	125
set (timing valves)	176	engine (into subassemblies).....	17
wash	74	engine (rear section).....	139
Cylinder bore (See Bore, cylinder)		general instructions	51
Cylinder head temperature.....	189	Distributor and lines, priming, re-	
Cylinders		moval	26
assembly	168	Distributor blocks	
inspection of holes.....	86	connect	125
removal	39	end wire lengths.....	125
removal of parts.....	74	Drive, tachometer (See Tach-	
repair	93	ometer drive)	
Cylinders, crankcase main section		Drive, 3-way accessory	
assembly	109	inspection	146
cleaning	75	repair	150
inspection	79	Drive fit parts, repair.....	53
D		Drive gear, cranking motor	
Damper, dynamic		assembly	164
assembly	112	replacement of bushing.....	132, 148
inspection of bushings.....	89	Drive gear and support, impeller	
replacement of bushings.....	108	assembly	137
Data		inspection (drive gear).....	129
clutch assembly	202	removal	125
engine	8	replacement of gear bushing.....	132
ignition	16	Drive gear supports, generator	
Deflectors, air		assembly	155
inspection	77	disassembly	141
installation	171	drill retainer nut.....	151
removal	32	inspection	146
repair	91	repair	151

**ORDNANCE MAINTENANCE — 9-CYLINDER, RADIAL, GASOLINE ENGINE
(CONTINENTAL MODEL R975-C1)**

D — Contd.	Page	Page
Drive gears, accessory		disassembly
assembly	163	general instructions
inspection	131	into subassemblies
removal	49	rear section
Drive gears, cam		identification numbers (remark-
inspection (rear crankshaft).....	89	ing)
repair (crankcase main section)..	108	inspection
Drive shaft, accessory		engine
inspection	147	general instructions
installation	153	magnetic inspection
removal	144	rear section
repair	153	installation
replacement	148	front cover
Driven disk (clutch)		on overhaul stand.....
fits and tolerances.....	219	support beam
inspection	213	support tube
Drives, accessory, direction of rota-		overhaul of subassemblies
tion and ratio to crankshaft		introduction to
speed	8	testing after overhaul.....
Driving gear, accessory		removal
inspection	131	front cover
repair	134	support beam
		support tube
E		repair
Elbow, carburetor (See Carburetor		general instructions
and elbow)		rear section
Elbows, exhaust (See Exhaust		Exhaust elbows
elbows)		assembly
Elbows, terminal		removal
assembly	123	Exhaust valves (See Valves, exhaust)
replacement	92	
Emery cloth	53	F
Engine R975-C1, continental		Fan assembly
assembly		assembly
diffuser section to rear section	163	removal
engine	163	Ferrules, copper, installation.....
engine components	163	Fins (cylinder head)
engine parts	173	inspection
general instructions	57	repair
main section to rear section.....	164	Firing order (magnetos).....
rear section	153	Fits and tolerances (See Limits,
cleaning		table of; clutch)
engine	17	Flanges, intake and exhaust pipe,
engine parts	57	inspection
general instructions	51	Flanges, mounting
rear section	144	inspection
data	15	repair
description	8	Flanges, 3-way accessory drive,
		inspection

INDEX

F - Contd.	Page	Page
Flywheel		
inspection		146
assembly	183	149
data	202	
removal		
hub and flywheel.....	26	
hub retaining nut.....	25	
Flywheel ring		
assembly	213	
disassembly	206	
fits and tolerances.....	219	
inspection	213	
installation of pressure plate on..	215	
separate pressure plate from.....	206	
Fuel pressure	189	
Fuel pump AC-BF (See TM 9-1828A)		
Fuel pump RE-F8 (See TM 9-1750D)		
Fuel pumps		
assembly	156	
direction of rotation and ratio to crankshaft speed	8	
installation	187	
removal	18	
inspection		146
repair		149
Generator		
assembly of drive gear support....	155	
direction of rotation and ratio to crankshaft speed	8	
disassembly of drive gear sup- port	141	
inspection	146	
installation		
generator	186	
idler gear	155	
support bracket	187	
removal		
generator	18	
idler gear	144	
repair of drive gear support....	151	
Governor		
installation	186	
removal	18	
Guide, valve tappet, replacement..	105	
Guides (See Valve guides)		

G

Gear and support, impeller drive shaft	
assembly	134
inspection	130
removal	129
repair	133
Gears, accessory drive (3-way), inspection	146
Gears, accessory drive idler	
assembly	139
removal	125
replacement	131
Gears, crankshaft	
assembly	110, 164
inspection	
(front) gear	61
(rear) gear	89
installation	117
removal	45
repair	
(front) gear	62
(rear) gear	108
Gears, generator, repair.....	151
Gears, main oil pump	
assembly	157

H

Housing, crankcase	
inspection	
front section	60
rear section	144
repair	
front section	62
rear section	148
Housing, diffuser section	
inspection	129
repair	131, 132
Housing, main oil pump	
assembly	157
inspection	145
Housing, push rod	
inspection	78
installation	171
removal	32
repair	93
Housing, 3-way accessory drive	
assembly	156
disassembly	139
inspection	146
installation	185
removal	22
repair	150

**ORDNANCE MAINTENANCE — 9-CYLINDER, RADIAL, GASOLINE ENGINE
(CONTINENTAL MODEL R975-C1)**

I	Page	K	Page
Idler gear, generator		Knuckle pins (crankcase)	
inspection (gear and shaft).....	146	inspection	
installation	155	pin holes	86
removal	144	pins	83
repair (gear and shaft).....	151	removal	63
Idler gears, accessory drive		repair pins	99
assembly	139	replace bushings	99
removal	125		
replacement	131	L	
Ignition		Lever, clutch release	
data	16	adjustment of lever height.....	216
connect manifold halves.....	123	attach to spring retainer.....	215
manifold rewiring chart.....	120	removal	206
(See also Wires, Wiring harness, ignition and Spark plugs)		Limits, table of	
Impeller, supercharger		clutch	219
assembly		engine	
drive gear and support.....	137	clearance values	191
drive shaft gear and support....	134	tightening and installation (torque values)	199
impeller	137	use of	53
shaft rear ball bearing cage.....	134	Lubrication, description of system..	11
diameter and ratio.....	15		
direction of rotation and ratio to crankshaft speed	8	M	
inspection	129, 130	MWO (Modification Work Orders)	7
removal		Machining dimensions	54
drive gear and support.....	125	Machining Oilite bushings.....	57
drive shaft gear and support....	124	Magnaflux parts (rear crankshaft), inspection	88
impeller	126	Magneto	
repair	133	assembly (conduits)	124
replacement (drive gear bushing)	132	check after overhaul.....	188
Identification numbers, remarking..	53	data	16
Inserts (See Valve seat inserts)		direction of rotation and ratio to crankshaft speed	8
Inspection		installation	
clutch	212	Bosch magnetos	181
crankcase		magneto drives	153
front section	60	Scintella magnetos	179
main section	76, 87	point setting	
diffuser section	129	Bosch magnetos	181
engine	189	Scintella magnetos	180
engine rear section.....	144	removal	
general instructions	42	drive shafts	144
magnetic inspection	53	magnetos	18
Inspector (engine)	52	selection of	179
Intake valves (See Valves, intake and exhaust)		Magneto BO-MJT9A306 (See TM 9-1750C)	

INDEX

M — Contd.		Page		Page
Magneto SCI-VAG-9-DFÁ (See TM 9-1750D)			Oil sump	
Major unit assembly replacement record	7		inspection	77
Manifold, ignition			installation	
connect halves	123		oil sump	168
rewiring chart	120		tubes	171
Manifolds, exhaust			removal	
inspection	77		oil sump	43
installation	183		tubes	38
removal	25		repair	92
repair	92		Oilholes, blank off.....	177
			Oil-impregnated bearings, cleaning	52
			Oilite bushings, machining.....	57
			Overhaul	
			crankcase front section.....	58
			diffuser section	125
			engine	
			rear section	139
			subassemblies	51
			testing after	188
			Overhaul stand (See Stand, over- haul)	
			P	
			Pipes, exhaust, inspection of mount- ing flanges	81
			Pipes, intake	
			inspection	
			mounting flanges	81
			pipes	76
			installation	171
			removal	38
			repair	91
			Piston rings	
			assembly	
			rings	119
			rings on piston.....	118
			check gap	118
			inspection	
			groove	81
			lands	82
			removal	63
			Pistons	
			assembly	
			pistons and pins.....	168
			rings	119
			displacement	15
			inspection	
			pins and pin bores.....	82
			rings	81

ORDNANCE MAINTENANCE — 9-CYLINDER, RADIAL, GASOLINE ENGINE
(CONTINENTAL MODEL R975-C1)

P — Contd.	Page	Page
Pistons — Contd.		
removal		repair 92
pistons and pins..... 39		set 175
rings 63		Rocker box covers
repair 97		assembly 179
replacement of bushing..... 102		inspection 77
Plates (clutch)		removal 31
assembly (pressure plate)..... 213		repair 92
fits and tolerances		Rollers (crankcase)
driving plate 220		inspection 79
pressure plate 219		installation 92
disassembly (pressure plate)..... 206		repair 93
inspection 213		
installation		S
driving plate separator studs... 216		Scratches, removal
pressure plate 214, 215		connecting rods 104
separate from flywheel..... 206		engine parts 56
Plugs (crankshaft), assembly.. 110, 111		Sealing compounds 54
Primer system		Serial numbers (engine)..... 8, 15
inspection 77		Shipping (engine), data..... 15
installation 173		Sleeve, clutch release
repair 91		installation (sleeve and bearing) 215
Pump, fuel (See Fuel pumps)		removal
Pump, oil (See Oil pump, main)		bearing from sleeve..... 208
Pump, scavenger		sleeve and bearing..... 206
assembly 63		Spacers, bearing
inspection 61		assembly
repair 62		accessory drive shaft..... 134
Push rods		front bearing 111
inspection 78		rod bearing 112
installation 171		removal
removal (housing) 32		diffuser section 129
repair 93		master rod thrust bearing..... 87
		Spare parts, installation..... 57
R		Spark plugs
Repair		data 16
clutch 212		inspection (inserts) 81
crankcase		installation
front section 62		front plug wires..... 123
main section 91, 104		front plugs 183
diffuser section 131		rear plug wires..... 122
general instructions 53		rear plugs 171
rear section of engine..... 148		removal 31
Rewiring chart, ignition manifold.. 120		replacement of inserts..... 97
Rocker arms		Specifications, clutch assembly..... 202
inspection 77		Spindle, clutch
installation 171		assembly 216
removal 31		disassembly 211
		fits and tolerances..... 220

**ORDNANCE MAINTENANCE — 9-CYLINDER, RADIAL, GASOLINE ENGINE
(CONTINENTAL MODEL R975-C1)**

W	Page		Page
Washers (crankcase)		place in holding fixture.....	120
assembly of cylinders.....	109	replacement	92
inspection	78	test wires and identify ends.....	122
repair	93	Wiring harness, ignition	
Wires		assembly	119
distributor block end wire lengths	125	inspection	77
installation		installation	168
lock wire	57	removal	43
wires	122, 123	repair	91