

J  
408.3  
A5  
COPY 2

UNCLASSIFIED TM 9-1750F  
~~RESTRICTED~~

WAR DEPARTMENT  
TECHNICAL MANUAL  
ORDNANCE MAINTENANCE  
**POWER UNIT FOR  
MEDIUM TANKS M3A4 AND M4A4**  
APRIL 6, 1943

DECLASSIFIED  
Auth: MND 775126  
By NNHP NARS 3-3-78

This record was previously  
allocated to RG 319 (Entry  
No. 382) and is now assigned  
to RG 287. REGRADED UNCLASSIFIED BY  
AUTHORITY OF DOD DIR. 5200.1 R  
BY Rakes ON 06/06/06

**FOR ORDNANCE PERSONNEL ONLY**

UNCLASSIFIED

RESTRICTED

TECHNICAL MANUAL }  
 No. 9-1750F }

WAR DEPARTMENT  
 Washington, April 6, 1943

ORDNANCE MAINTENANCE

**POWER UNIT FOR  
 MEDIUM TANKS M3A4 AND M4A4**

Prepared under the direction of the  
 Chief of Ordnance

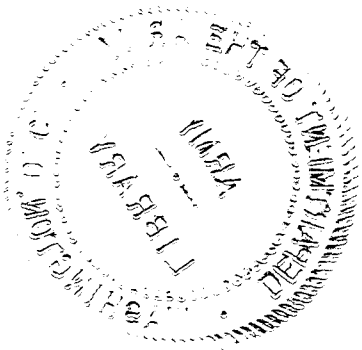
(with the cooperation of the Chrysler Corporation)

**CONTENTS**

	Paragraphs	Pages
CHAPTER 1. Introduction .....	1- 5	3-18
CHAPTER 2. Power unit .....	6-41	19-272
SECTION I. Power unit .....	6-10	19-53
II. Trouble shooting .....	11-13	54-61
III. Removal .....	14	62
IV. Disassembly of power unit .....	15-16	63-76
V. Disassembly of individual engine .....	17	77-82
VI. Inspection and repair of parts .....	18-22	83-124
VII. Assembly of individual engine .....	23	125-168

**ORDNANCE MAINTENANCE – POWER UNIT FOR  
 MEDIUM TANKS M3A4 AND M4A4**

	Paragraphs	Pages
SECTION VIII. Assembly of power unit .....	24–25	169–240
IX. Adjustments and tests before installation .....	26–29	241–252
X. Installation .....	30	253
XI. Limits and tolerances .....	31–32	254–258
XII. Special engine tools .....	33	259–260
XIII. Preparation for extreme conditions .....	34–38	261–262
XIV. Packing, shipping, and storage .....	39–41	263–272
CHAPTER 3. Power unit ignition system .....	42–64	273–300
SECTION I. Power unit ignition system .....	42–45	273–275
II. Trouble shooting .....	46–48	276–285
III. Instrument box ignition switch, ignition solenoid switch, ignition filter, ignition coil, high-tension wiring harness, and spark plugs .....	49–54	286–287
IV. Ignition distributor .....	55–63	288–299
V. Limits and tolerances .....	64	300
CHAPTER 4. References .....	65–66	301–303
INDEX .....		304–308



CHAPTER 1

INTRODUCTION

Paragraph

Scope .....	1
Nature of materiel .....	2
Characteristics .....	3
Organization maintenance .....	4
References .....	5

1. SCOPE.

a. This manual is published for the information and guidance of ordnance maintenance personnel. It contains detailed instructions for inspection, disassembly, assembly, maintenance, and repair of the power unit for Medium Tanks M3A4 and M4A4, supplementary to those in the field and technical manuals prepared for the using arms. Additional descriptive matter and illustrations are included to aid in providing a complete working knowledge of the materiel.

2. NATURE OF MATERIEL.

a. The power unit consists of 5 L-head, water-cooled engines mounted radially on a common crankcase. These power units are used in the Medium Tanks M3A4 and M4A4.

3. CHARACTERISTICS.

a. Power units are numbered serially. All power units used in the Medium Tank M3A4 and in medium tanks with serial numbers M4A4-1001 to M4A4-2304 inclusive, incorporate multiple water pumps, one mounted on each engine (figs. 1 and 2). Power units of the Medium Tank M4A4 with serial numbers following M4A4-2304 incorporate a single water pump (mounted on the distributor end of the crankcase (fig. 3). On power units equipped with multiple water pumps, the generator is mounted on No. 2 engine and driven by the No. 2 engine water pump belt (fig. 1). The fuel pump is mounted on the distributor end of the crankcase and driven by the accessory shaft (fig. 1). On power units equipped with the single water pump, the generator is mounted in the fighting compartment and belt driven from the propeller shaft. The fuel pump is mounted on the distributor end of No. 4 engine and driven by the camshaft (fig. 3). Power units of Medium Tank M4A4 with serial numbers M4A4-1001 to M4A4-3211 inclusive, are equipped

ORDNANCE MAINTENANCE — POWER UNIT FOR  
MEDIUM TANKS M3A4 AND M4A4

RA PD 300573

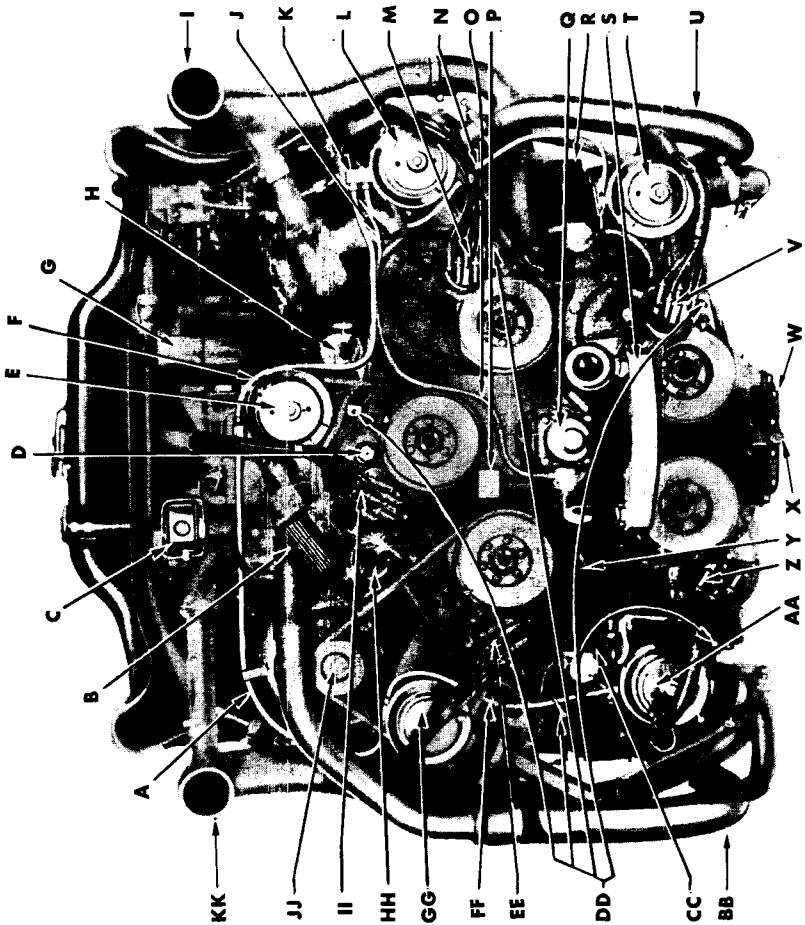


Figure 1 — M3A4 Power Unit, Distributor End

INTRODUCTION

- A—TUBE, WATER PUMP AIR RELIEF (ENGINE NO. 1 TO NO. 2)
- B—COIL, IGNITION, ASSEMBLY (NO. 1 ENGINE)
- C—CLEANER, AIR, CRANKCASE VENTILATOR, ASSEMBLY
- D—SHAFT, DRIVE, TACHOMETER
- E—PUMP, WATER, ASSEMBLY (NO. 1 TO NO. 5 ENGINE)
- F—TUBE, WATER PUMP AIR RELIEF (NO. 1 ENGINE)
- G—FILTER, OIL (ABSORPTION TYPE)
- H—COIL, IGNITION (NO. 5 ENGINE)
- I—PIPE, EXHAUST (NOS. 4 AND 5 ENGINES)
- J—TUBE, FUEL PUMP TO BRANCH CONNECTION, ASSEMBLY (FOR NOS. 4 AND 5 CARBURETORS)
- K—CONNECTION, WATER PUMP AIR RELIEF TUBE
- L—PUMP, WATER, ASSEMBLY (NO. 5 ENGINE)
- M—DISTRIBUTOR, IGNITION, ASSEMBLY (NO. 5 ENGINE)
- N—TUBE, WATER PUMP AIR RELIEF (NO. 4 TO NO. 5 ENGINE)
- O—TUBE, FUEL PUMP TO NO. 1 CARBURETOR, ASSEMBLY
- P—PLATE, SERIAL NUMBER, ENGINE
- Q—PUMP, FUEL, ASSEMBLY
- R—COIL, IGNITION, ASSEMBLY (NO. 4 ENGINE)
- S—SUPPORT, ENGINE, REAR
  
- T—PUMP, WATER, ASSEMBLY (NO. 4 ENGINE)
- U—TUBE, RADIATOR OUTLET, ASSEMBLY (NOS. 4 AND 5 ENGINES)
- V—DISTRIBUTOR, IGNITION, ASSEMBLY (NO. 4 ENGINE)
- W—PAN, OIL
- X—PLUG, DRAIN, OIL PAN
- Y—TUBE, FUEL PUMP TO BRANCH CONNECTION, ASSEMBLY (FOR NOS. 2 AND 3 CARBURETORS)
- Z—DISTRIBUTOR, IGNITION, ASSEMBLY (NO. 3 ENGINE)
- AA—PUMP, WATER, ASSEMBLY (NO. 3 ENGINE)
- BB—TUBE, RADIATOR OUTLET, ASSEMBLY (NOS. 2 AND 3 ENGINES)
- CC—COIL, IGNITION, ASSEMBLY (NO. 3 ENGINE)
- DD—COCK, DRAIN, CYLINDER WATER JACKET, ASSEMBLY
- EE—DISTRIBUTOR, IGNITION, ASSEMBLY (NO. 2 ENGINE)
- FF—TUBE, WATER PUMP AIR RELIEF (NO. 2 TO NO. 3 ENGINE)
- GG—PUMP, WATER, ASSEMBLY (NO. 2 ENGINE)
- HH—COIL, IGNITION, ASSEMBLY (NO. 2 ENGINE)
- II—DISTRIBUTOR, IGNITION, ASSEMBLY (NO. 1 ENGINE)
- JJ—GENERATOR, ASSEMBLY
- KK—PIPE, EXHAUST (NOS. 1, 2 AND 3 ENGINES)

Legend For Figure 1 — M3A4 Power Unit, Distributor End

## ORDNANCE MAINTENANCE – POWER UNIT FOR MEDIUM TANKS M3A4 AND M4A4

with thermostats in the cooling system, mounted in the engine water outlet adapter of each engine. A bypass type of thermostat, mounted in the radiator inlet adapters of engines Nos. 2, 3, 4, and 5 and in the cylinder head adapter of No. 1 engine entered production on power units starting with serial numbers M4A4-3211 of Medium Tank M4A4 (fig. 195). The clutch, of the fully enclosed type, was used in production of the power unit of the Medium Tank M4A4 with serial numbers from M4A4-1001 to M4A4-4412 inclusive (fig. 6). Beginning with the power unit for the Medium Tank M4A4 above serial numbers M4A4-4413, a clutch of the ventilated type entered production.

### 4. ORGANIZATION MAINTENANCE.

a. **Scope.** The scope of maintenance and repair by the crew and other units of the using arms is determined by the availability of suitable tools, availability of necessary parts, capabilities of the mechanics, time available, and the tactical situation. All of these are variable and no exact system of procedure can be prescribed.

b. **Allocation Of Maintenance.** Indicated below are the maintenance duties for which tools and parts have been provided for the using arm personnel. Other replacements and repairs are the responsibility of ordnance maintenance personnel but may be performed by using arm personnel when circumstances permit, within the discretion of the commander concerned. Echelons and words as used in this list of maintenance allocations are defined as follows:

**SECOND ECHELON:** Line organization regiments, battalions, companies, detachments, and separate companies.

**THIRD ECHELON:** Ordnance light maintenance companies, ordnance medium maintenance companies, ordnance divisional maintenance battalions, and post ordnance shops.

**FOURTH ECHELON:** Ordnance heavy maintenance companies, and service command shops.

**FIFTH ECHELON:** Ordnance base regiments, ordnance bases, arsenals, and manufacturers' plants.

**SERVICE** (including preventive maintenance): Refer to AR 850-15, paragraph 23 a (1) and (2). Consists of servicing, cleaning, lubricating, tightening bolts and nuts, and making external adjustments of subassemblies or assemblies and controls.

**INTRODUCTION**

**REPLACE:** Refer to AR 850-15, paragraph 23 a (4). Consists of removing the part, subassembly or assembly from the vehicles and replacing it with a new or reconditioned or rebuilt part, subassembly or assembly, whichever the case may be.

**REPAIR:** Refer to AR 850-15, paragraph 23 a (3) and (5), in part. Consists of making repairs to, or replacement of the part, subassembly or assembly that can be accomplished without completely disassembling the subassembly or assemblies, and does not require heavy welding, or riveting, machining, fitting and/or alining or balancing.

**REBUILD:** Refer to AR 850-15, paragraph 23 a (5), in part, and (6). Consists of completely reconditioning and replacing in serviceable condition any unserviceable part, subassembly or assembly of the vehicle, including welding, riveting, machining, fitting, alining, balancing, assembling and testing.

**NOTE:** Operations allocated will normally be performed in the echelon indicated by "X." Operations allocated to the echelons as indicated by "E" may be accomplished by the respective echelons in emergencies only.

	ECHELONS			
	2nd	3rd	4th	5th
<b>BOXES AND RACKS, AMMUNITION</b>				
Boxes, ammunition — replace .....	X			
Boxes, ammunition — repair .....		X		
Racks, ammunition — replace .....	X			
Racks, ammunition — repair .....		X		
<b>CONTROLS, BRACKETS AND LEVERS</b>				
Brackets and levers — replace .....	X			
Brackets and levers — repair .....		X		
Controls and linkage — replace .....	X			
Controls and linkage — repair .....		X		
<b>DRIVE, FINAL (GEAR TRAIN ASSEMBLY) (1-PIECE)</b>				
*Drive, final, gear train assembly — replace .....		X		
Drive, final, gear train assembly — repair .....		X		
Drive, final, gear train assembly — rebuild .....			E	X
<b>DIFFERENTIAL, CONTROLLED, CARRIER ASSEMBLY AND SUBASSEMBLY</b>				
Differential, controlled, assembly — replace .....		X		
Differential, controlled, assembly — repair .....		E	X	

\*The second echelon is authorized to remove and reinstall power units, transmission assemblies, final drive, gear train assemblies and other items marked by asterisk. However, when it is necessary to replace an item marked by an asterisk with a new or rebuilt part, subassembly or unit assembly, the assembly marked by asterisk will not be removed from the vehicle by the second echelon until authorization is received from a higher echelon.



ORDNANCE MAINTENANCE — POWER UNIT FOR  
MEDIUM TANKS M3A4 AND M4A4

RA PD 25426

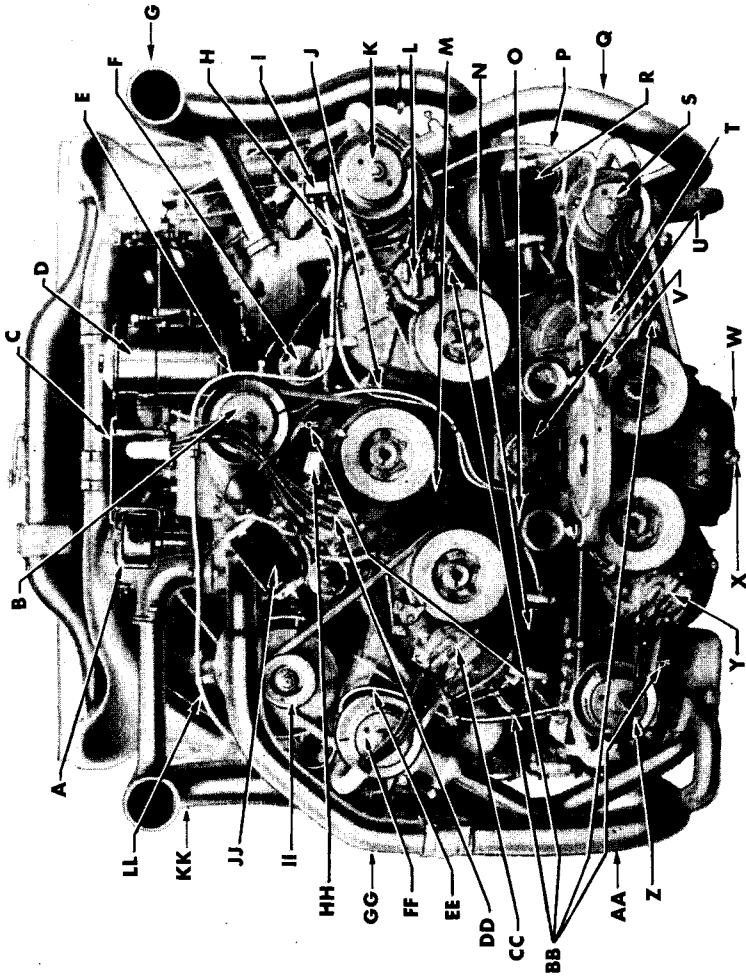


Figure 2 — M4A4 Power Unit, Distributor End (Multiple Water Pump Type)

## INTRODUCTION

- A**—CLEANER, AIR, CRANKCASE VENTILATOR, ASSEMBLY
- B**—PUMP, WATER, ASSEMBLY (NO. 1 ENGINE)
- C**—PLATE, ENGINE LIFTER AND STEP, ASSEMBLY
- D**—FILTER, OIL, W/CLAMP, ASSEMBLY
- E**—TUBE, WATER PUMP AIR RELIEF (NO. 1 TO NO. 5 ENGINE)
- F**—COIL, IGNITION, ASSEMBLY (NO. 5 ENGINE)
- G**—PIPE, EXHAUST (NOS. 4 AND 5 ENGINES)
- H**—TUBE, FUEL PUMP TO BRANCH CONNECTION, ASSEMBLY (FOR NOS. 4 AND 5 CARBURETORS)
- I**—CONNECTION, WATER PUMP AIR RELIEF
- J**—TUBE, FUEL PUMP TO NO. 1 CARBURETOR, ASSEMBLY
- K**—PUMP, WATER, ASSEMBLY (NO. 5 ENGINE)
- L**—DISTRIBUTOR, IGNITION, ASSEMBLY (NO. 5 ENGINE)
- M**—PLATE, SERIAL NUMBER, ENGINE
- N**—COIL, IGNITION, ASSEMBLY (NO. 3 ENGINE)
- O**—TUBE, FUEL PUMP TO BRANCH CONNECTION, ASSEMBLY (FOR NOS. 2 AND 3 CARBURETORS)
- P**—TUBE, WATER PUMP AIR RELIEF (NO. 4 TO NO. 5 ENGINE)
- Q**—TUBE, RADIATOR OUTLET, ASSEMBLY (NOS. 4 AND 5 ENGINES)
- R**—COIL, IGNITION, ASSEMBLY (NO. 4 ENGINE)
- S**—PUMP, WATER, ASSEMBLY (NO. 4 ENGINE)
- T**—DISTRIBUTOR, IGNITION, ASSEMBLY (NO. 4 ENGINE)
- U**—PUMP, FUEL, ASSEMBLY
- V**—SUPPORT, ENGINE, REAR
- W**—PAN, OIL, ASSEMBLY
- X**—PLUG, DRAIN, OIL PAN
- Y**—DISTRIBUTOR, IGNITION, ASSEMBLY (NO. 3 ENGINE)
- Z**—PUMP, WATER, ASSEMBLY (NO. 3 ENGINE)
- AA**—TUBE, RADIATOR OUTLET, ASSEMBLY (NOS. 2 AND 3 ENGINES)
- BB**—COCK, DRAIN, CYLINDER WATER JACKET, ASSEMBLY
- CC**—DISTRIBUTOR, IGNITION, ASSEMBLY (NO. 2 ENGINE)
- DD**—DISTRIBUTOR, IGNITION, ASSEMBLY (NO. 1 ENGINE)
- EE**—TUBE, WATER PUMP AIR RELIEF (NO. 2 TO NO. 3 ENGINE)
- FF**—PUMP, WATER, ASSEMBLY (NO. 2 ENGINE)
- GG**—CONNECTION, RADIATOR OUTLET TUBE, ASSEMBLY (NO. 1 ENGINE)
- HH**—GEAR, REDUCTION, TACHOMETER DRIVE, ASSEMBLY
- II**—GENERATOR, ASSEMBLY
- JJ**—COIL, IGNITION, ASSEMBLY (NO. 1 ENGINE)
- KK**—PIPE, EXHAUST (NOS. 1, 2 AND 3 ENGINES)
- LL**—TUBE, WATER PUMP AIR RELIEF (NO. 1 TO NO. 2 ENGINE)
- RA PD 25426B**

**Legend For Figure 2 — M4A4 Power Unit, Distributor End (Multiple Water Pump Type)**

**ORDNANCE MAINTENANCE — POWER UNIT FOR  
MEDIUM TANKS M3A4 AND M4A4**

	2nd	ECHELONS		
		3rd	4th	5th
<b>DIFFERENTIAL, CONTROLLED, CARRIER ASSEMBLY AND SUBASSEMBLY — (Cont.)</b>				
Differential, controlled, assembly — rebuild .....			E	X
Drum, steering brake — replace .....		X		
Drum, steering brake — repair .....			X	
Shoe, steering brake — replace .....	X			
Shoe, steering brake — repair (reline) .....		X		
<b>REDUCTION, FINAL</b>				
Hub, sprocket — replace .....	X			
Hub, sprocket — repair .....		X		
Hub, sprocket — rebuild .....			E	X
Reduction assembly, final drive — replace .....	X			
Reduction assembly, final drive — repair .....		X		
Reduction assembly, final drive — rebuild .....			E	X
Sprocket — replace .....	X			
Sprocket — rebuild .....			E	X
<b>TRANSMISSION ASSEMBLY</b>				
Brakes, parking — replace .....	X			
Brakes, parking — repair (reline) .....		X		
*Transmission assembly — replace .....		X		
Transmission assembly — repair .....		X		
Transmission assembly — rebuild .....			E	X
<b>DRIVE, FINAL (GEAR TRAIN ASSEMBLY) (3-PIECE)</b>				
*Drive, final, gear train assembly — replace .....		X		
Drive, final, gear train assembly — repair .....		X		
Drive, final, gear train assembly — rebuild .....			E	X
<b>DIFFERENTIAL, CONTROLLED, CARRIER ASSEMBLY</b>				
Differential, controlled, assembly — replace .....		X		
Differential, controlled, assembly — repair .....		E	X	
Differential, controlled, assembly — rebuild .....			E	X
<b>DIFFERENTIAL, CONTROLLED, SUBASSEMBLY</b>				
Differential, controlled, subassembly — replace .....		X		
Differential, controlled, subassembly — repair .....		E	X	
Differential, controlled, subassembly — rebuild .....			E	X
Drum, steering brake — replace .....		X		
Drum, steering brake — repair .....			X	
Shoe, steering brake — replace .....	X			
Shoe, steering brake — repair (reline) .....		X		

\*The second echelon is authorized to remove and reinstall power units, transmission assemblies, final drive, gear train assemblies and other items marked by asterisk. However, when it is necessary to replace an item marked by an asterisk with a new or rebuilt part, subassembly or unit assembly, the assembly marked by asterisk will not be removed from the vehicle by the second echelon until authorization is received from a higher echelon.

INTRODUCTION

ELECTRICAL SYSTEM	ECHELONS			
	2nd	3rd	4th	5th
Battery — service, replace and recharge .....	X			
Battery — repair .....		X		
Battery — rebuild .....			E	X
Box, apparatus (generator control) — replace .....	X			
Box, apparatus (generator control) — repair .....		X		
Box, apparatus (generator control) — rebuild .....			X	
Box, battery — replace .....	X			
Box, battery — repair .....		X		
Box, terminal — replace .....	X			
Box, terminal — repair .....		X		
Box, turret collector ring — replace .....	X			
Box, turret collector ring — repair .....		X		
Box, turret collector ring — rebuild .....			X	
Brackets, mounting and supports — replace .....	X			
Brackets, mounting and supports — repair .....		X		
Breakers, circuit — replace .....	X			
Breakers, circuit — repair .....		X		
Breakers, circuit — rebuild .....			X	
Cables, battery — replace .....	X			
Cables, battery — repair .....		X		
Conduits — replace .....	X			
Filters, generator — replace .....	X			
Filters, generator — repair .....		X		
Generator, auxiliary assembly — replace .....	X			
Generator, auxiliary assembly — repair .....		X		
Generator, auxiliary assembly — rebuild .....			E	X
Lamps, all — service or replace .....	X			
Lamps, all — repair .....		X		
Siren — replace .....	X			
Siren — repair .....		X		
Siren — rebuild .....			X	
Solenoids — replace .....	X			
Solenoids — repair .....		X		
Switches — replace .....	X			
Switches — repair .....		X		
Switches — rebuild .....			X	
Wires — replace .....	X			

ORDNANCE MAINTENANCE — POWER UNIT FOR  
MEDIUM TANKS M3A4 AND M4A4

RA PD 25542

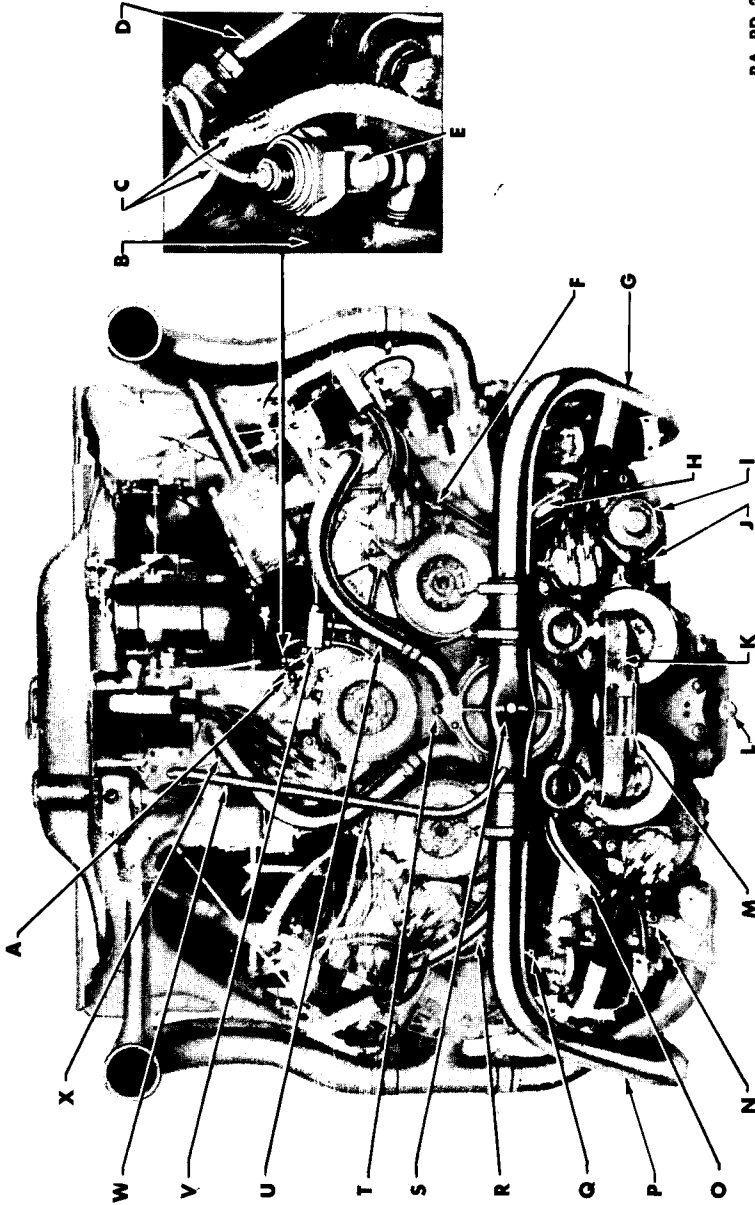


Figure 3 — M4A4 Power Unit, Distributor End (Single Water Pump Type)

## INTRODUCTION

- A—COCK, DRAIN, ENGINE CYLINDER WATER JACKET ASSEMBLY  
(ENGINE NO. 1)
- B—BLOCK, ENGINE CYLINDER (ENGINE NO. 1)
- C—HARNES, ENGINE WIRING, ASSEMBLY
- D—TUBE, OUTLET, OIL FILTER ASSEMBLY
- E—UNIT, SENDING, ENGINE OIL PRESSURE WARNING INDICATOR
- F—COCK, DRAIN, ENGINE CYLINDER WATER JACKET, ASSEMBLY  
(ENGINE NO. 5)
- G—TUBE, OUTLET, RADIATOR, RIGHT ASSEMBLY
- H—TUBE, OUTLET, WATER PUMP, ASSEMBLY (ENGINE NO. 4)
- I—PUMP, FUEL, ASSEMBLY
- J—COCK, DRAIN, ENGINE CYLINDER WATER JACKET, ASSEMBLY  
(ENGINE NO. 4)
- K—SUPPORT, ENGINE, REAR
- L—PLUG, DRAIN, OIL PAN
- M—PLATE, NAME, ENGINE SERIAL NUMBER
- N—COCK, DRAIN, ENGINE CYLINDER WATER JACKET, ASSEMBLY  
(ENGINE NO. 3)
- O—TUBE, OUTLET, WATER PUMP ASSEMBLY (ENGINE NO. 3)
- P—TUBE, OUTLET, RADIATOR, LEFT, ASSEMBLY
- Q—COCK, DRAIN, ENGINE CYLINDER WATER JACKET, ASSEMBLY  
(ENGINE NO. 2)
- R—TUBE, OUTLET, WATER PUMP, ASSEMBLY (ENGINE NO. 2)
- S—PUMP, WATER ASSEMBLY
- T—FITTING, GREASE, WATER PUMP BODY
- U—TUBE, OUTLET, WATER PUMP, ASSEMBLY (ENGINE NO. 5)
- V—CONNECTION, MAIN BRANCH, FUEL PUMP TO CARBURETOR  
TUBE ASSEMBLY
- W—TUBE, OVERFLOW, RADIATOR, ASSEMBLY
- X—TUBE, OUTLET, WATER PUMP, ASSEMBLY (ENGINE NO. 1)
- RA PD 255428

*Legend For Figure 3 — M4A4 Power Unit, Distributor End (Single Water Pump Type)*

ORDNANCE MAINTENANCE — POWER UNIT FOR  
MEDIUM TANKS M3A4 AND M4A4

POWER UNIT	ECHELONS			
	2nd	3rd	4th	5th
Bearings, connecting rod — replace .....		E	E	X
Bearings, crankshaft — replace .....		E	E	X
Breather, crankcase — service and replace .....	X			
Breather, crankcase — repair .....		X		
Carburetor and governor assemblies — replace .....	E	X		
(Governor must be set after installation)				
Carburetor and governor assemblies — repair .....		X		
Carburetor and governor assemblies — rebuild .....			X	
Clutch assembly — replace .....	X			
Clutch assembly — repair .....		X		
Clutch assembly — rebuild .....			E	X
Coils, ignition — replace .....	X			
Controls and linkage, carburetor and choke — service and replace .....	X			
Controls and linkage, carburetor and choke — repair .....		X		
Cooling system — service .....	X			
Damper, vibration — replace .....	X			
Distributor assemblies — service and replace .....	X			
Distributor assemblies — repair .....		X		
Distributor assemblies — rebuild .....			X	
Fan assembly — replace .....	X			
Fan assembly — repair .....		X		
Fan assembly — rebuild .....			E	X
Filters, fuel — service and replace .....	X			
Filters, fuel — repair .....		X		
Filters, ignition circuit — replace .....	X			
Filters, ignition circuit — repair .....		X		
Filters, oil (bypass) — service and replace .....	X			
Filters, oil (bypass) — repair .....		X		
Flywheel assembly — replace .....	X			
Flywheel assembly — repair .....		X		
Flywheel assembly — rebuild .....			E	X
Gaskets, cylinder head — replace .....	X			
Gaskets, exhaust and intake manifold — replace .....	X			
Gear, camshaft — replace .....		E	X	
Heads, cylinder — replace .....		X		
Heads, cylinder — repair .....			X	
Lines, fuel — replace .....	X			
Lines, fuel — repair .....		X		
Lines, oil (external) — replace .....	X			
Lines, oil (external) — repair .....		X		

INTRODUCTION

POWER UNIT — (Cont.)	ECHELONS			
	2nd	3rd	4th	5th
Manifolds, exhaust and intake — replace	E	X		
Manifolds, exhaust and intake — repair		X		
Mounts, engine — replace	X			
Pan, oil — clean and replace gaskets	X			
Pistons and rings — replace		E	E	X
Plugs, spark — replace	X			
Plugs, spark (2-piece) — repair		X		
*Power unit assembly — replace		X		
Power unit assembly — repair		X		
Power unit assembly — rebuild			E	X
Pump assemblies, fuel — replace	X			
Pump assemblies, fuel — repair		X		
Pump assemblies, fuel — rebuild			X	
Pump assemblies, water — replace	X			
Pump assemblies, water — repair		X		
Pump assemblies, water — rebuild			X	
Pump assembly, oil, pressure and scavenger — replace and repair		X		
Pump assembly, oil, pressure and scavenger — rebuild			E	X
Radiator assembly — replace	X			
Radiator assembly — repair		X		
Radiator assembly — rebuild			E	X
Starter assembly — replace	X			
Starter assembly — repair		X		
Starter assembly — rebuild			X	
Strainer, fuel — service and replace	X			
Strainer, fuel — repair		X		
Thermostat, water — replace	X			
Units, signal, oil (sending) — replace	X			
Units, signal, water (sending) — replace	X			
EXTINGUISHING SYSTEM, FIRE				
Controls, remote — replace (CO <sub>2</sub> )	X			
Controls, remote — repair (CO <sub>2</sub> )		X		
Cylinders (CO <sub>2</sub> ) — replace	X			
Cylinders (CO <sub>2</sub> ) — repair or recharge		X		
Extinguishers, fire, assembly — replace and refill (CCL <sub>4</sub> )		X		

\*The second echelon is authorized to remove and reinstall power units, transmission assemblies, final drive, gear train assemblies and other items marked by asterisk. However, when it is necessary to replace an item marked by an asterisk with a new or rebuilt part, subassembly or unit assembly, the assembly marked by asterisk will not be removed from the vehicle by the second echelon until authorization is received from a higher echelon.



**ORDNANCE MAINTENANCE — POWER UNIT FOR  
MEDIUM TANKS M3A4 AND M4A4**

	ECHELONS			
	2nd	3rd	4th	5th
EXTINGUISHING SYSTEM, FIRE — (Cont.)				
Extinguishers, fire, assembly — rebuild (CCL <sub>4</sub> ) .....			E	X
Lines and nozzles (CO <sub>2</sub> ) — replace .....	X			
Lines and nozzles (CO <sub>2</sub> ) — repair .....		X		
FUEL SYSTEM				
Cleaners, carburetor, air — replace .....	X			
Cleaners, carburetor, air — repair .....			X	
Filter — service or replace .....	X			
Filter — repair .....			X	
Lines, valves and fittings — replace .....	X			
Lines, valves and fittings — repair .....	E	X		
Tanks, fuel — replace .....	X			
Tanks, fuel — repair .....			X	
HULL				
Bracket, engine support — replace .....			E	X
Doors, and cover plates — replace .....	X			
Doors and cover plates — repair .....		E	X	
Guards, mud — replace .....	X			
Guards, mud — repair .....		X		
Hull — repair .....		X		
Hull — rebuild .....			E	X
Insulation and padding — replace .....	X			
Periscope — replace .....	X			
Periscope — repair .....		X		
Periscope — rebuild .....			E	X
Seats — replace .....	X			
Seats — repair .....		X		
INSTRUMENTS AND PANELS				
Instruments — replace .....	X			
Instruments — repair .....		X		
Instruments — rebuild .....			E	X
Panel and connections — replace .....	X			
Panel and connections — repair .....		X		
LUBRICATION SYSTEM				
Cooler, oil, engine, and transmission — replace .....	X			
Cooler, oil, engine, and transmission — repair .....		X		
Cooler, oil, engine, and transmission — rebuild .....			E	X
Filter, engine oil — replace .....	X			
Filter, engine oil — repair .....		X		
Lines, oil, engine, and transmission — replace .....	X			
Lines, oil, engine, and transmission — repair .....		X		
Tank, engine oil — replace .....	X			
Tank, engine oil — repair .....		X		

INTRODUCTION

	ECHELONS			
	2nd	3rd	4th	5th
<b>SHAFT, PROPELLER, AND UNIVERSAL JOINT ASSEMBLY</b>				
Shaft propeller, and universal joint assembly — replace .....	X			
Shaft, propeller, and universal joint assembly — repair....		X		
Shaft, propeller, and universal joint assembly — rebuild .....			E	X
<b>SUSPENSION SYSTEM, TRACK</b>				
Bearings and seals, bogie and idler wheels — replace .....	X			
Bogie components — replace .....	X			
Bogie components — repair .....		X		
Bogie components — rebuild .....			E	X
Bracket, idler — replace .....	E	X		
Bracket, idler — repair .....		X		
Bracket, idler — rebuild .....			E	X
Roller and bracket assembly, track supporting — replace .....	X			
Roller and bracket assembly, track supporting — repair .....		X		
Roller and bracket assembly, track supporting — rebuild .....			E	X
Track assembly — replace or repair .....	X			
Track assembly — rebuild .....			E	X
Wheels, bogie — replace .....	X			
Wheels, bogie — repair (replace tire) .....		X		
Wheels, idler — replace .....	X			
Wheels, idler — repair .....		X		
Wheels, idler — rebuild .....			E	X
<b>TURRET ASSEMBLY</b>				
Basket, turret — replace and repair .....		X		
Basket, turret — rebuild .....			E	X
Brake assembly — replace .....	X			
Brake assembly — repair .....		X		
Mechanism, traversing (manual) — replace .....	X			
Mechanism, traversing (manual) — repair .....		X		
Mechanism, traversing (manual) — rebuild .....			X	
Ring, turret — replace .....		E	X	
Turret assembly — replace or repair .....		X		
Turret assembly — rebuild .....			E	X

ORDNANCE MAINTENANCE — POWER UNIT FOR  
MEDIUM TANKS M3A4 AND M4A4

	VEHICLE ASSEMBLY	ECHELONS			
		2nd	3rd	4th	5th
Tank assembly — service and preventive maintenance	.....				X
Tank assembly — rebuild (with serviceable assemblies)	.....			X	E

5. REFERENCES.

a. The last section of this manual lists all technical manuals, standard nomenclature lists, and publications relative to the materiel described herein.

CHAPTER 2

POWER UNIT

Section I

POWER UNIT

	Paragraph
General .....	6
Description .....	7
Tabulated data and specifications .....	8
Second echelon operations .....	9
Organization maintenance .....	10

6. GENERAL.

a. **Power Unit Serial Numbers.** The power units are numbered serially, the M3A4 Power Unit starting with serial number M3A4-1001 and ending with serial number M3A4-1146; the M4A4 Power Unit starts with serial number M4A4-1001. This serial number is stamped on a metal plate. The plate is, in turn, attached to the distributor end of the crankcase on the model M3A4 and also on the model M4A4 Power Units equipped with multiple water pumps (fig. 1). On model M4A4 Power Units equipped with single water pump, this plate is attached to the power unit rear support (fig. 2).

7. DESCRIPTION.

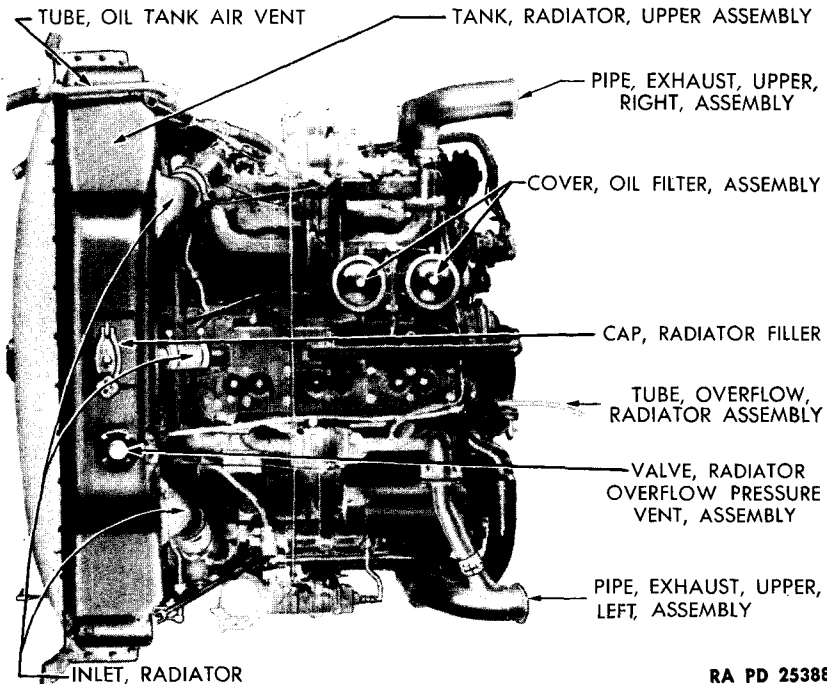
a. **Power Unit.**

(1) The power unit consists of 5 engines assembled to a common crankcase.

(2) In describing the power unit, reference will be made to the "distributor" end, and "radiator" end. All reference to "right" or "left" sides will be as viewed from the distributor end. Reference to "rotation" will be as viewed from the distributor end.

(3) Each bank of cylinders is in itself a conventional L-head engine in that it has its own crankshaft, pistons, camshaft, valves, manifold, carburetor, and distributor, and in this text will be referred to as engines Nos. 1, 2, 3, 4, and 5. Facing the distributor end of the power unit (fig. 1), and with No. 1 engine at the top, the engines are numbered counterclockwise, with No. 2 engine to the left and below No. 1 engine.

**ORDNANCE MAINTENANCE — POWER UNIT FOR  
MEDIUM TANKS M3A4 AND M4A4**



RA PD 25388

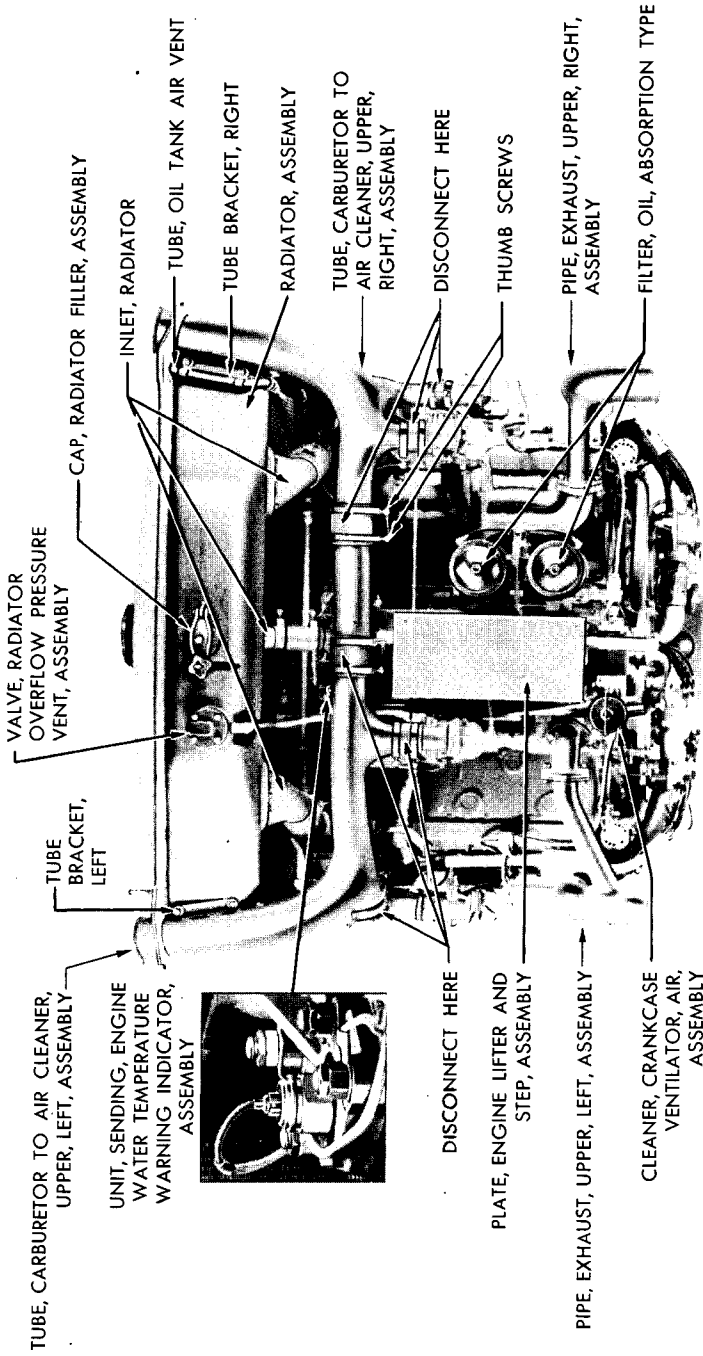
**Figure 4 — M3A4 Power Unit, Top**

The cylinders of each engine are numbered in order, starting at the distributor end. Rotation of each engine is counterclockwise.

(4) The power unit is supported at the radiator end by 2 supports bolted 1 to each side of the power unit drive gear housing (fig. 8). These supports are rubber insulated and rest on 2 mating supports (fig. 15), mounted by bolts to the side of the hull. The distributor end of the power unit is supported by a rubber insulated single mount (fig. 13), centrally located at the extreme rear of the power unit compartment. The electrical connection between power unit and frame of the vehicle is accomplished by means of a ground strap connected between the engine rear support and the engine rear support bracket (fig. 13).

(5) **CRANKCASE.** The crankcase is 1-piece and of cast-iron construction. Oil passages, to provide lubrication for the moving parts of the individual engines, are cast and drilled in the crankcase. These passages are closed by inserting plugs in the openings, thus eliminating any danger of oil leakage. Passages are also cast in the crankcase to permit drainage of oil from all engine sumps to the oil sump at the bottom of the crankcase. A pan, equipped with a strainer, is bolted to the bottom of the crankcase.

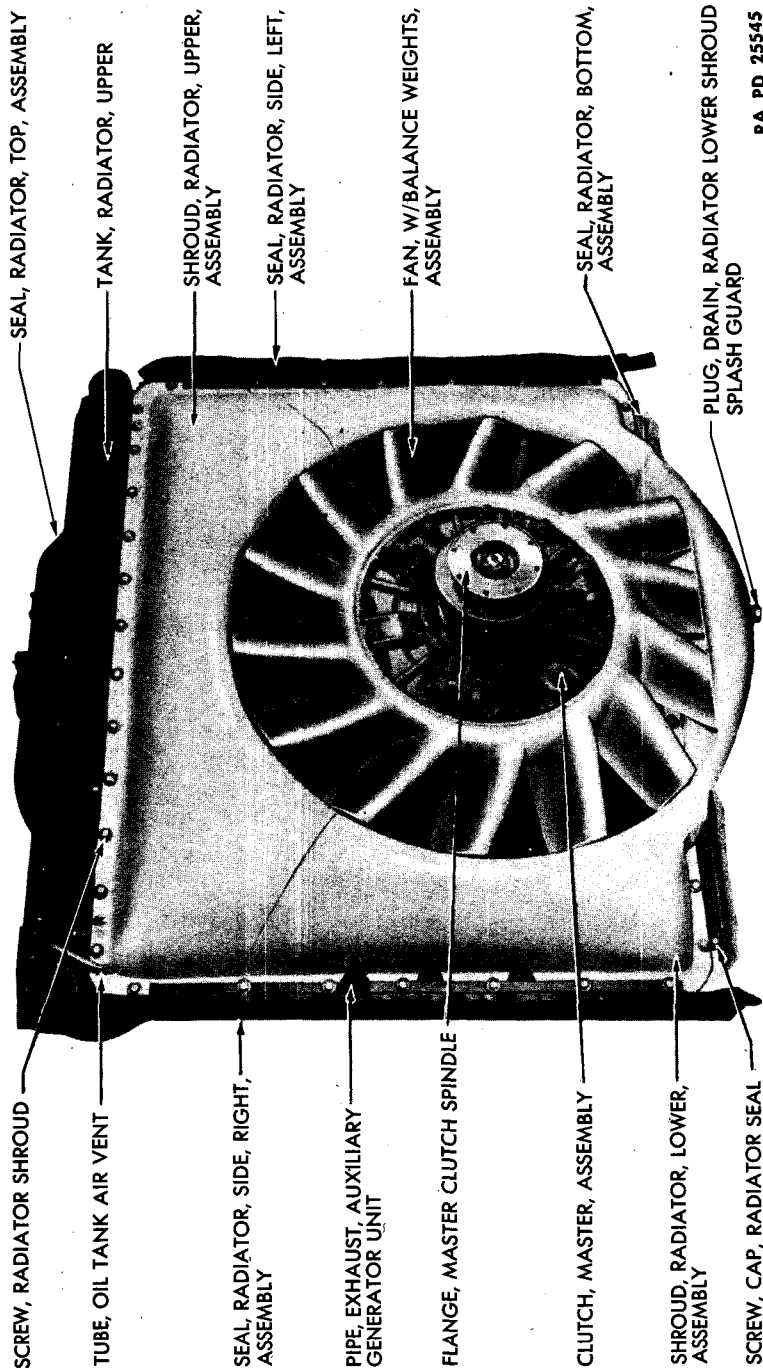
POWER UNIT



RA PD 25429

Figure 5 — M4A4 Power Unit, Top (Single Water Pump Type)

ORDNANCE MAINTENANCE – POWER UNIT FOR  
MEDIUM TANKS M3A4 AND M4A4



RA PD 25545

Figure 6 – M4A4 Power Unit, Fan End

## POWER UNIT

### (6) POWER UNIT DRIVE GEAR HOUSING.

(a) The drive gear housing contains 5 engine drive gears which are driven by the engine crankshafts through a sleeve connecting the drive gear to a gear which is bolted to the end of the engine crankshaft. These gears, in turn, drive a large gear which is keyed to the power unit driven gear shaft. This shaft, in turn, drives the engine clutch.

(b) Lubrication of the gears in the drive gear housing is accomplished by oil which is forced through openings in the plugs in the radiator end of the oil galleries of engines Nos. 1, 2, and 5. Oil is also supplied through the outlet lines from the 2 absorption type oil filters which are mounted on the No. 1 engine. After lubricating the gears, the oil drains to the power unit oil sump through an opening at the bottom of the crankcase.

(c) Gears in the gear housing are of the herringbone type and are stamped with Nos. 1, 2, 3, 4, and 5 for synchronizing purposes. The sleeves which transmit engine crankshaft rotation to the engine drive gear are stamped with a zero to assist in synchronizing the engines.

(7) FLYWHEEL. The flywheel is of cast-iron construction and is mounted on the output shaft of the drive gear housing.

(8) POWER UNIT FAN. A single fan, of aluminum construction, is bolted to the flywheel, supplying air for cooling of the power unit.

(9) POWER UNIT LUBRICATION. The supply of oil for the power unit is contained in the oil supply tank, located in the fighting compartment. Flexible tubing connects the oil supply tank to the power unit. An oil cooler, located in the bulkhead of the vehicle, cools the oil before it is delivered to the oil supply tank.

(10) CRANKCASE VENTILATION. Exhaust gases, which may accumulate in the crankcase, are expelled through a tube connected to the left side of No. 1 engine, at the radiator end (or to the valve spring cover of No. 1 engine, on later models), and extending through the rear wall of the power unit compartment to the top of the oil tank.

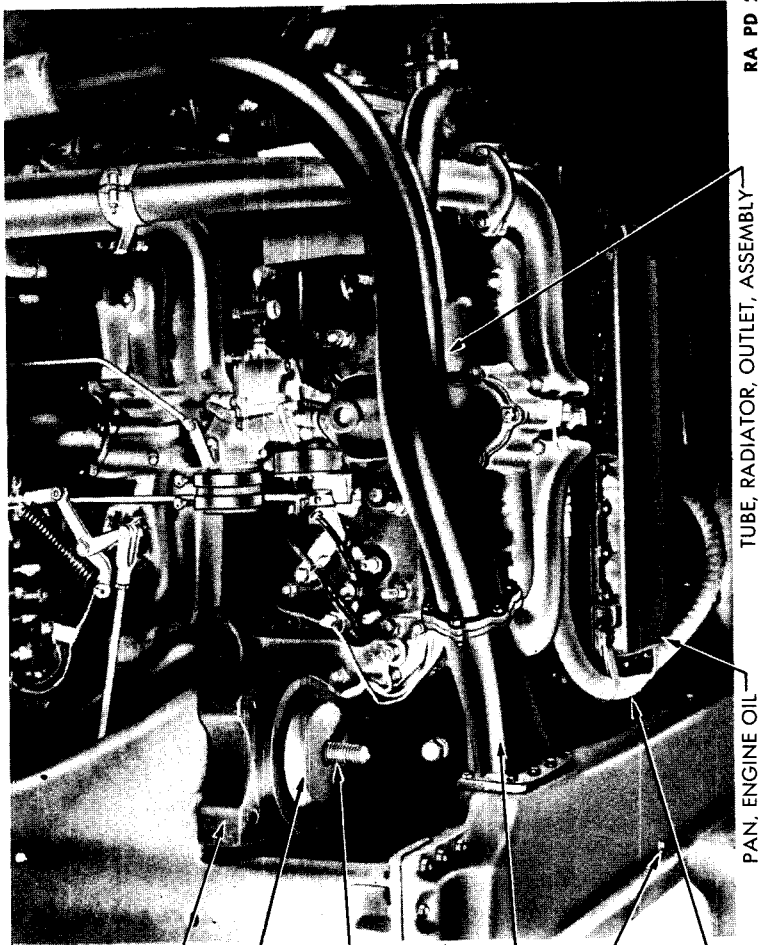
### (11) WATER PUMP.

(a) On the model M3A4 and the first production of model M4A4 power units, the water pump is bolted to the distributor end of each individual engine and belt-driven by the crankshaft impulse neutralizer. The pulley is pinned to the outer end of the drive shaft, which, in turn, carries the vaned impeller on the inner end. The shaft is supported in the housing by 2 sealed ball bearings. Water is delivered from the pump direct to the cylinder block.

(b) On later production of model M4A4 power units, a single water pump is bolted to the distributor end of the crankcase and driven



ORDNANCE MAINTENANCE — POWER UNIT FOR  
MEDIUM TANKS M3A4 AND M4A4



RADIATOR, ASSEMBLY →

SUPPORT, ENGINE, FRONT, LEFT

INSULATOR, ENGINE FRONT  
SUPPORT, LOWER, ASSEMBLY

BOLT, ENGINE SUPPORT  
INSULATOR

TANK, RADIATOR, LOWER →

OUTLET, ADAPTER,  
RADIATOR, LEFT

PLUG, DRAIN, RADIATOR TANK

HOSE, ENGINE OUTLET TO  
RADIATOR, OIL, ASSEMBLY

PAN, ENGINE OIL →

TUBE, RADIATOR, OUTLET, ASSEMBLY →

RA PD 25389

Figure 7 — M3A4 Power Unit, Left Side And Bottom

POWER UNIT

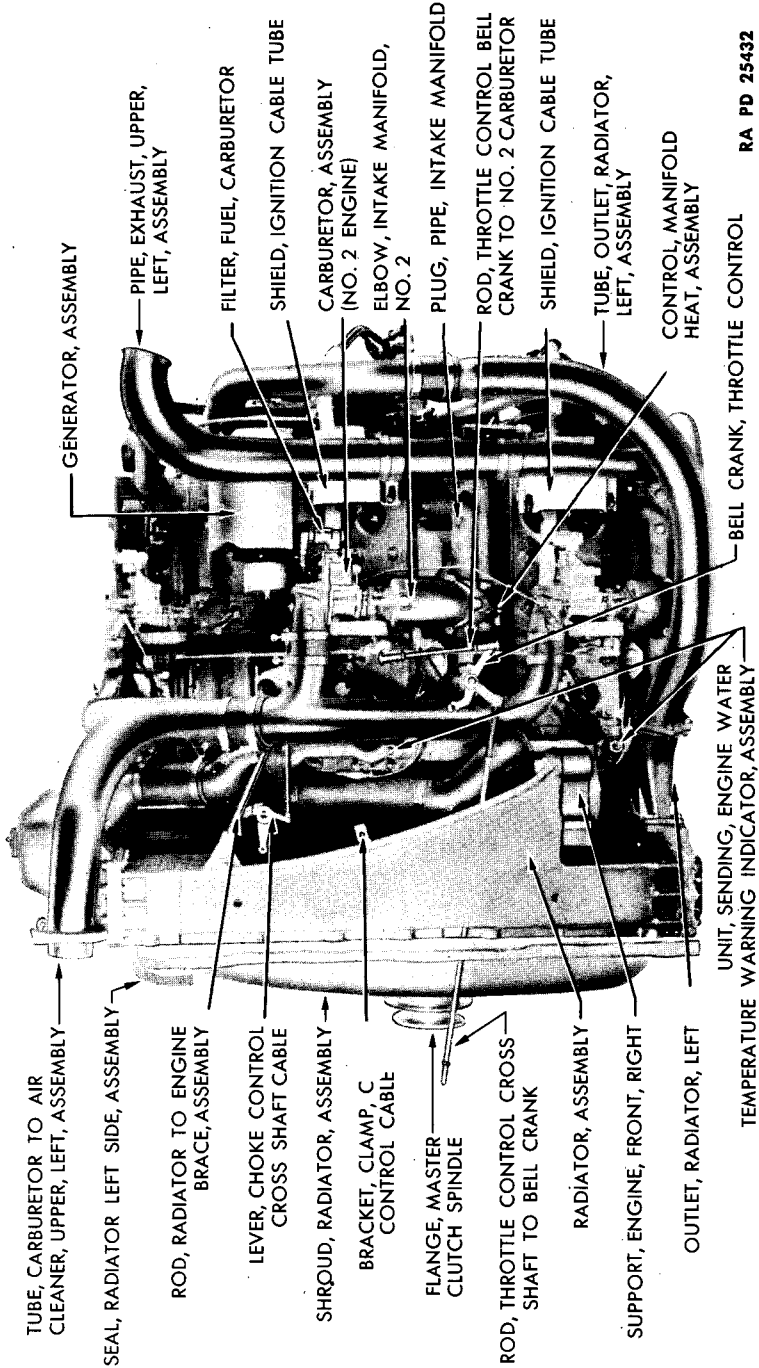


Figure 8 — M3A4 And M4A4 Power Unit, Left Side (Multiple Water Pump Type)

ORDNANCE MAINTENANCE — POWER UNIT FOR  
MEDIUM TANKS M3A4 AND M4A4

RA PD 25425

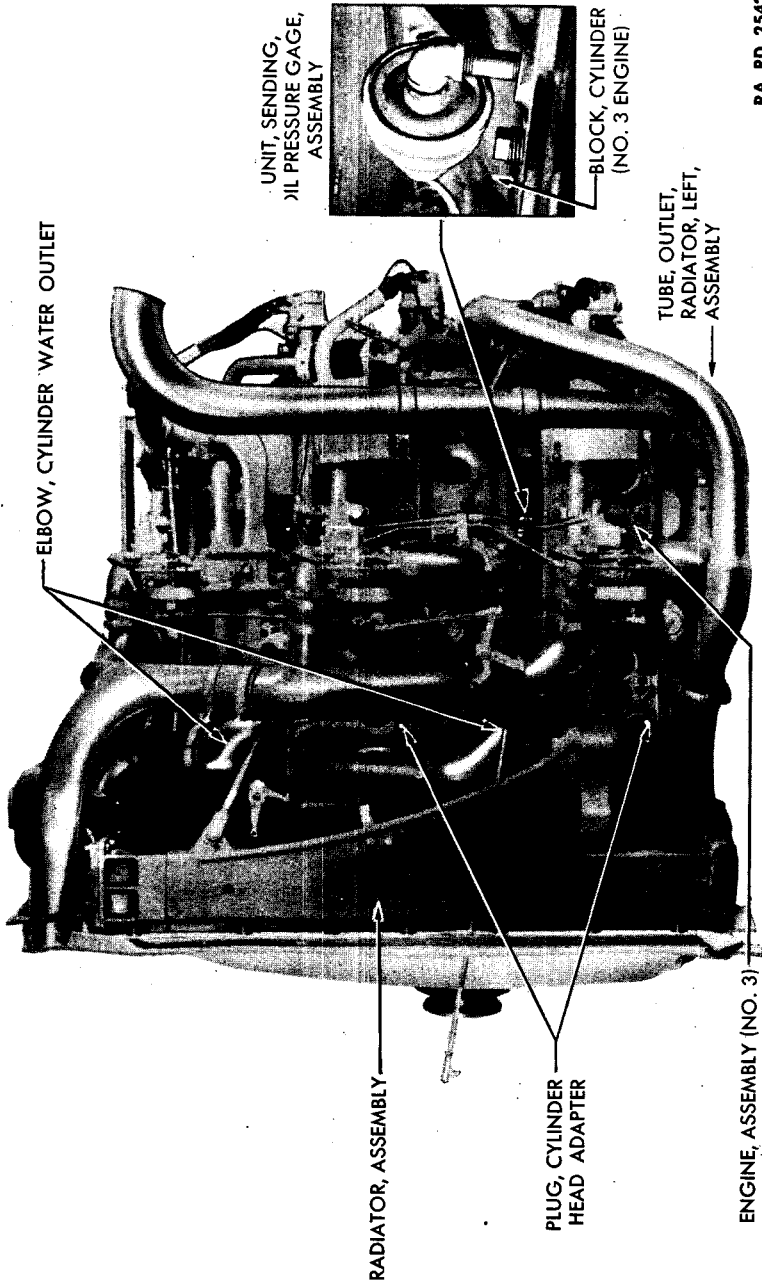


Figure 9 — M4A4 Power Unit, Left Side (Single Water Pump Type)

## POWER UNIT

direct by the accessory shaft. A vaned impeller is pinned to the water pump drive shaft which is supported in the housing by 2 ball bearings. Water is delivered by the pump, through tubes, to the distributor end of the individual engines.

### b. Individual Engine (figs. 16, 17, 18, 19 and 20).

#### (1) CYLINDER BLOCK.

(a) *General.* The cylinder block is of 1-piece, cast-iron construction. Oil passages are drilled in the cylinder block to provide lubrication to crankshaft bearings, camshaft bearings, and valve lifters. Cored passages provide circulation of water the full length of the cylinders, and a water distributor tube directs water around the valve ports to provide better cooling. The cylinder bores are ground and honed.

(b) Main bearings are held in place by caps which are secured to cylinder block by special alloy cap screws and lock washers. These caps are line-reamed in place on cylinder block; therefore they are not interchangeable. Both cylinder block and crankshaft bearing caps have machined grooves to locate the bearings.

(2) **CYLINDER HEAD.** A cylinder head of cast-iron construction is mounted on each individual engine and held in place by 21 studs and nuts. The head covers the top of the cylinder block and forms the top of the combustion chambers. A gasket between cylinder head and cylinder block prevents water, air, or compression leakage.

#### (3) CRANKSHAFT AND MAIN BEARINGS.

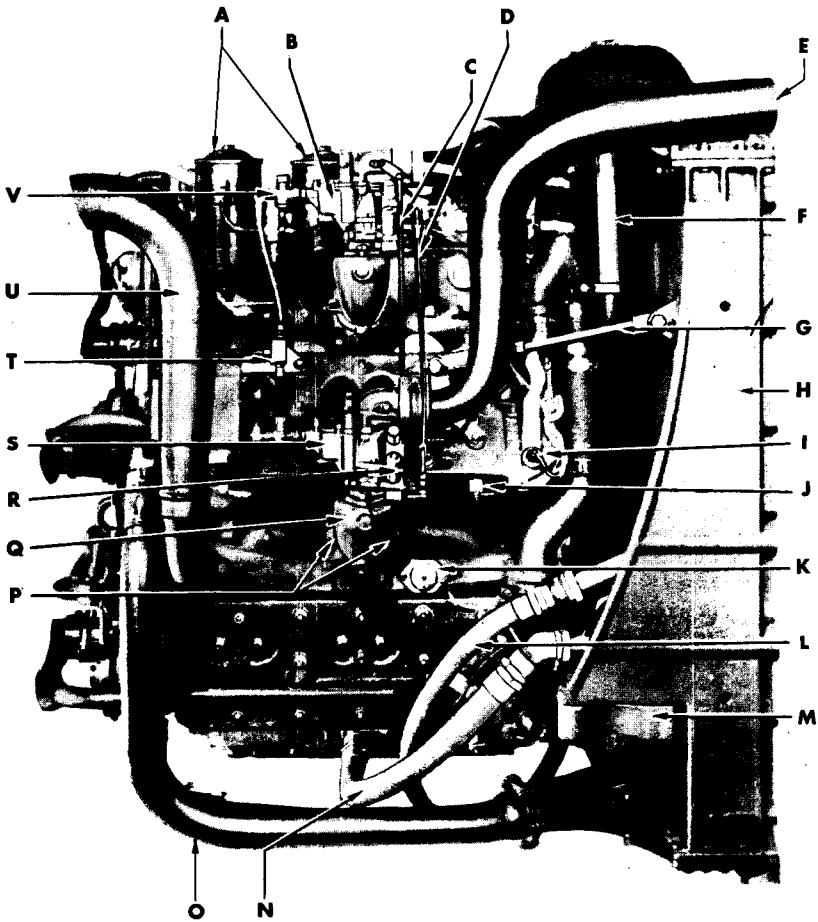
(a) *General.* The crankshaft is a steel forging, balanced both dynamically and statically. Counterweights are integral with the crankshaft and reduce main bearing loads. The shaft is drilled to provide lubrication to the connecting rod bearings.

(b) *Bearings.* The crankshaft is suspended by 4 steel-backed, babbitt-lined bearings (fig. 18). These bearings require no scraping, reaming, or burnishing. Bearings Nos. 1, 2, and 3, both upper and lower, are interchangeable. Bearing No. 4 is longer, and both upper and lower halves are interchangeable. Flanges are provided to control and thrust. Ears are formed on each bearing half to provide a means of alining bearing in both cylinder block and bearing cap.

#### (4) CONNECTING ROD AND BEARINGS (fig. 18).

(a) *General.* The connecting rod is drop-forged and of "I" beam construction. Grooves are machined in both the connecting rod and cap to locate the bearings. A metered hole in the lower end of the rod provides lubrication for piston and piston pin. The connecting rod is

ORDNANCE MAINTENANCE — POWER UNIT FOR  
MEDIUM TANKS M3A4 AND M4A4



RA PD 25412

Figure 10 — M3A4 Power Unit, Right Side

**POWER UNIT**

- A**—FILTER, OIL, W/CLAMP, ASSEMBLY
- B**—CARBURETOR, ASSEMBLY (NO. 5 ENGINE)
- C**—ROD, CHOKE, ASSEMBLY (NO. 5 TO NO. 4 CARBURETOR)
- D**—ROD, THROTTLE CONTROL, ASSEMBLY (FROM NO. 4 TO NO. 5 CARBURETOR)
- E**—TUBE, CARBURETOR TO AIR CLEANER, UPPER, RIGHT, ASSEMBLY
- F**—HOSE, CRANKCASE VENT AIR CLEANER OUTLET PIPE
- G**—ROD, BRACE, RADIATOR TO ENGINE ASSEMBLY
- H**—RADIATOR, ASSEMBLY
- I**—UNIT, SENDING, ENGINE WATER TEMPERATURE GAGE, ASSEMBLY
- J**—UNIT, SENDING, ENGINE WATER TEMPERATURE WARNING INDICATOR, ASSEMBLY
- K**—UNIT, SENDING, EXHAUST STACK TEMPERATURE WARNING INDICATOR, ASSEMBLY
- L**—HOSE, ENGINE TO OIL COOLER (ENGINE END)
- M**—SUPPORT, ENGINE, FRONT, RIGHT
- N**—HOSE, OIL TANK TO ENGINE (ENGINE END)
- O**—TUBE, RADIATOR OUTLET, ASSEMBLY
- P**—STUD, ATTACHING, CARBURETOR ADAPTER ELBOW
- Q**—ELBOW, ADAPTER, CARBURETOR
- R**—GOVERNOR, CARBURETOR, ASSEMBLY
- S**—CARBURETOR, ASSEMBLY (NO. 4 ENGINE)
- T**—CONNECTION, BRANCH, FUEL PUMP TO NOS. 4 AND 5 CARBURETOR TUBE
- U**—PIPE, EXHAUST, UPPER, RIGHT, ASSEMBLY
- V**—FILTER, FUEL, CARBURETOR, ASSEMBLY

RA PD 25412B

**Legend For Figure 10 — M3A4 Power Unit, Right Side**

ORDNANCE MAINTENANCE — POWER UNIT FOR  
MEDIUM TANKS M3A4 AND M4A4

RA PD 25543

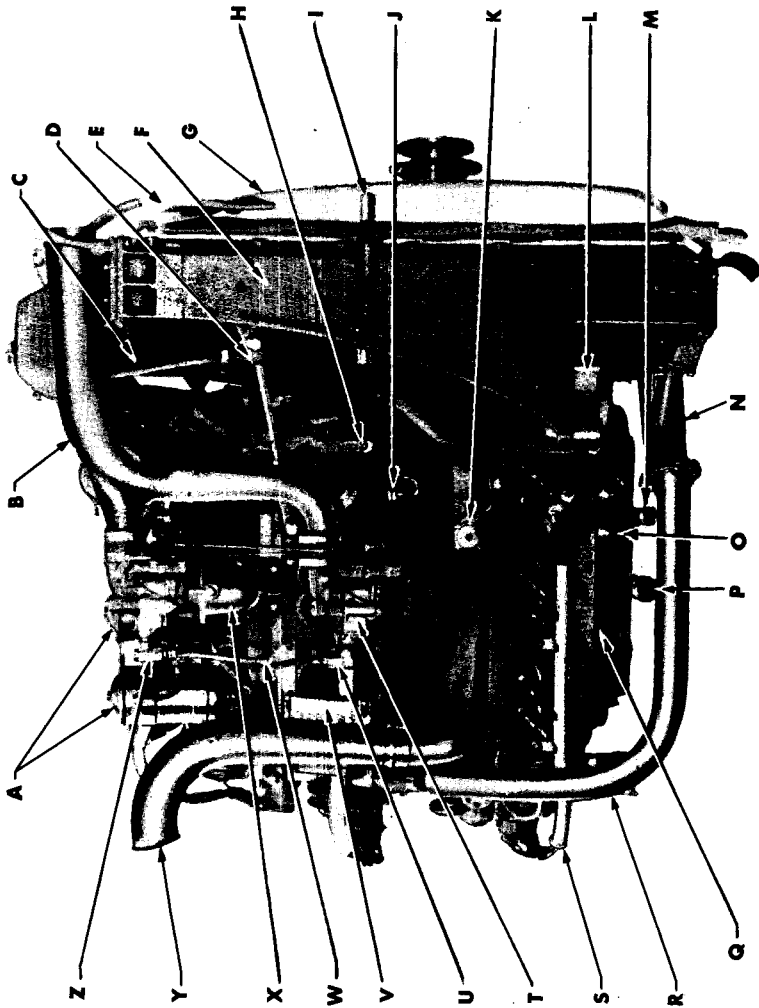


Figure 11 — M4A4 Power Unit, Right Side (Multiple Water Pump Type)

POWER UNIT

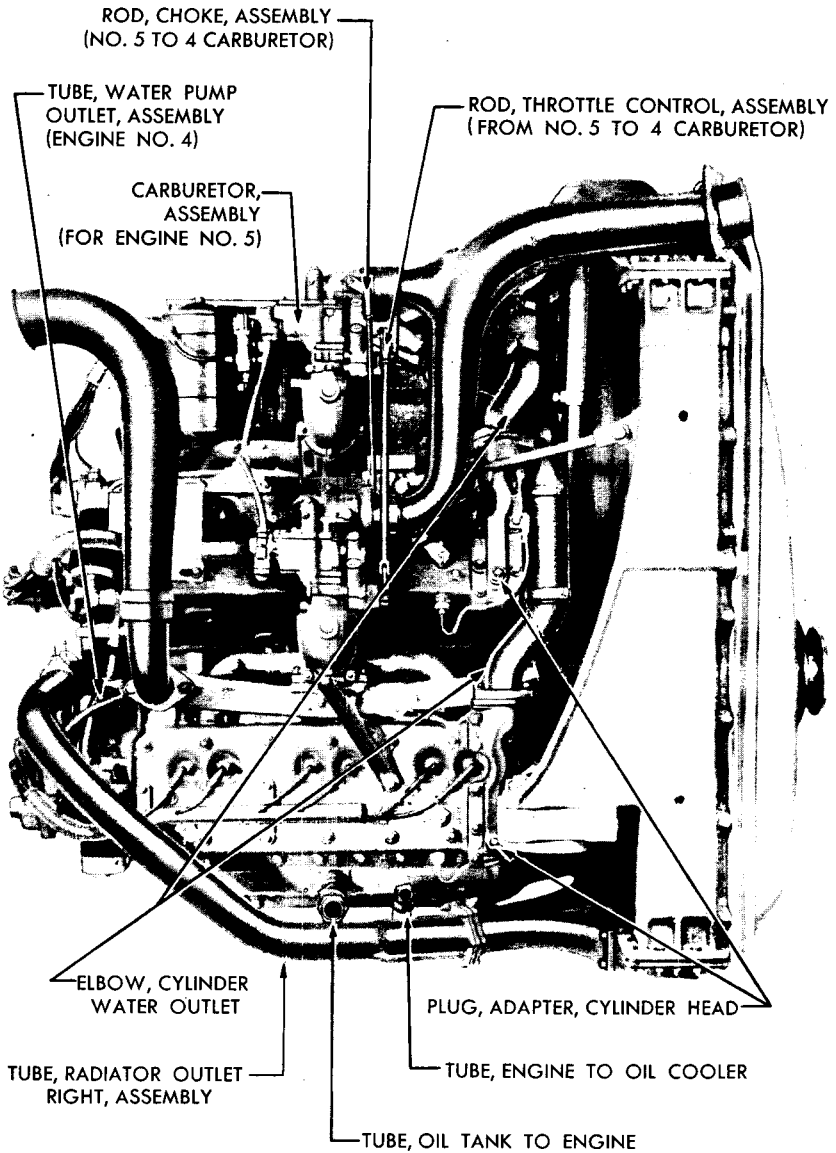
- A—FILTER, OIL, ENGINE, W/CLAMP, ASSEMBLY
- B—TUBE, CARBURETOR TO AIR CLEANER, UPPER, RIGHT, ASSEMBLY
- C—HOSE, ENGINE CRANKCASE VENT AIR CLEANER OUTLET PIPE
- D—ROD, BRACE, RADIATOR TO ENGINE, RIGHT, ASSEMBLY
- E—SEAL, RADIATOR, SIDE, RIGHT, ASSEMBLY
- F—RADIATOR, ASSEMBLY
- G—SHROUD, RADIATOR, ASSEMBLY
- H—UNIT, SENDING, ENGINE WATER TEMPERATURE WARNING INDICATOR, ASSEMBLY
- I—PIPE, EXHAUST, AUXILIARY GENERATOR UNIT
- J—UNIT, SENDING, ENGINE WATER TEMPERATURE GAGE, ASSEMBLY
- K—UNIT, SENDING, EXHAUST STACK TEMPERATURE WARNING INDICATOR, ASSEMBLY
- L—SUPPORT, ENGINE, FRONT, RIGHT
- M—HOSE, ENGINE TO OIL COOLER, ENGINE END, ASSEMBLY
- N—OUTLET, RADIATOR, RIGHT
- O—UNIT, SENDING, ENGINE OIL PRESSURE GAGE, ASSEMBLY
- P—HOSE, OIL TANK TO ENGINE, ENGINE END, ASSEMBLY
- Q—UNIT, SENDING, ENGINE OIL PRESSURE WARNING INDICATOR
- R—TUBE, OUTLET, RADIATOR, RIGHT, ASSEMBLY
- S—CABLE, SPARK PLUG, W/TUBE, ASSEMBLY
- T—CARBURETOR, ASSEMBLY (NO. 4 ENGINE)
- U—FILTER, FUEL, CARBURETOR, ASSEMBLY
- V—SHIELD, IGNITION CABLE TUBE
- W—CONNECTION, BRANCH, FUEL PUMP TO NOS. 4 AND 5 CARBURETOR TUBE
- X—ELBOW, ENGINE INTAKE MANIFOLD (ENGINE NO. 5)
- Y—PIPE, EXHAUST, UPPER, RIGHT, ASSEMBLY
- Z—FILTER, FUEL, CARBURETOR, ASSEMBLY

RA PD 25543B

Legend For Figure 11 — M4A4 Power Unit, Right Side (Multiple Water Pump Type)



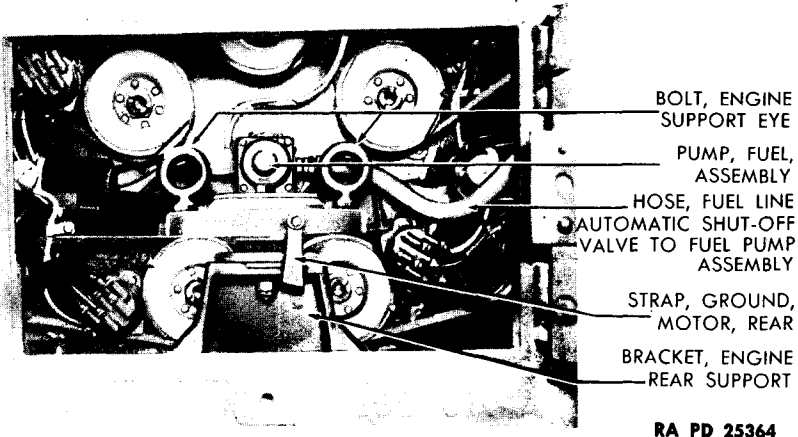
**ORDNANCE MAINTENANCE — POWER UNIT FOR  
MEDIUM TANKS M3A4 AND M4A4**



RA PD 25428

**Figure 12 — M4A4 Power Unit, Right Side (Single Water Pump Type)**

## POWER UNIT



RA PD 25364

**Figure 13 — M3A4 And M4A4 Power Unit, Viewed Through Power Unit Compartment Rear Door**

attached to the crankshaft by 2 bolts, nuts, and lock washers. Connecting rods are interchangeable.

(b) **Bearings.** Steel-backed, babbitt-lined bearings are used at the lower end of the connecting rod, between the rod and crankshaft. Ears formed on each bearing provide a means of locating bearing in connecting rod. These bearings are removable and are so finished that they require no scraping, reaming, or burnishing. They are of 2-piece construction, the upper and lower halves being interchangeable. A bronze and steel bushing is pressed into the upper end of the connecting rod to receive the piston pin.

(5) **CAMSHAFT** (figs. 16, 17, 19, and 20).

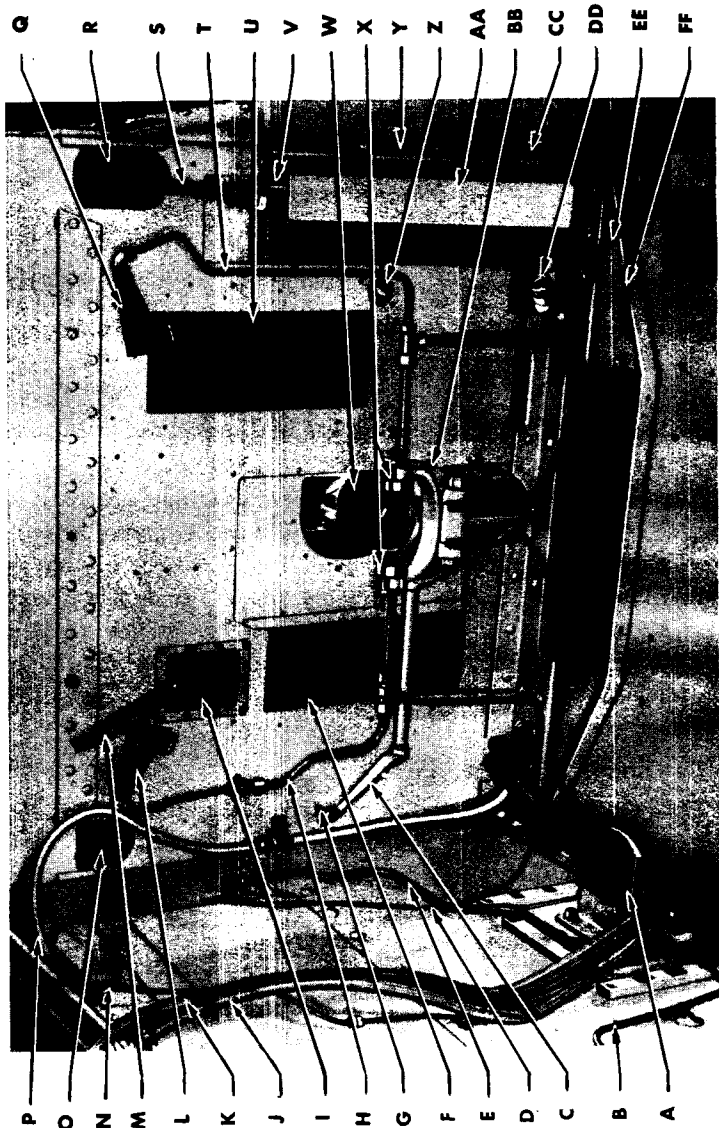
(a) The camshaft is of cast-iron construction, mounted in the engine cylinder block to the left of the crankshaft and directly below the valves. Integral with the camshaft are 12 cam lobes which operate the engine valves through tappets. Each cam operates one valve. The camshaft is supported in 3 steel-backed, babbitt, removable bearings, and 1 machined in the cylinder block. The 3 steel-backed, babbitt bearings, Nos. 1, 2 and 3, are removable and are so finished that they require no scraping, reaming, or burnishing.

(b) End play of the camshaft is controlled by the camshaft gear hub thrust plate (fig. 79).

(6) **TIMING GEARS** (fig. 107).

(a) The camshaft is driven at one-half crankshaft speed through helical cut gears mounted on the distributor end of camshaft and crankshaft. The camshaft gear is bolted to a camshaft gear hub, this

ORDNANCE MAINTENANCE — POWER UNIT FOR  
MEDIUM TANKS M3A4 AND M4A4



RA PD 25348

Figure 14 — Power Unit Compartment Used With M3A4 Power Unit

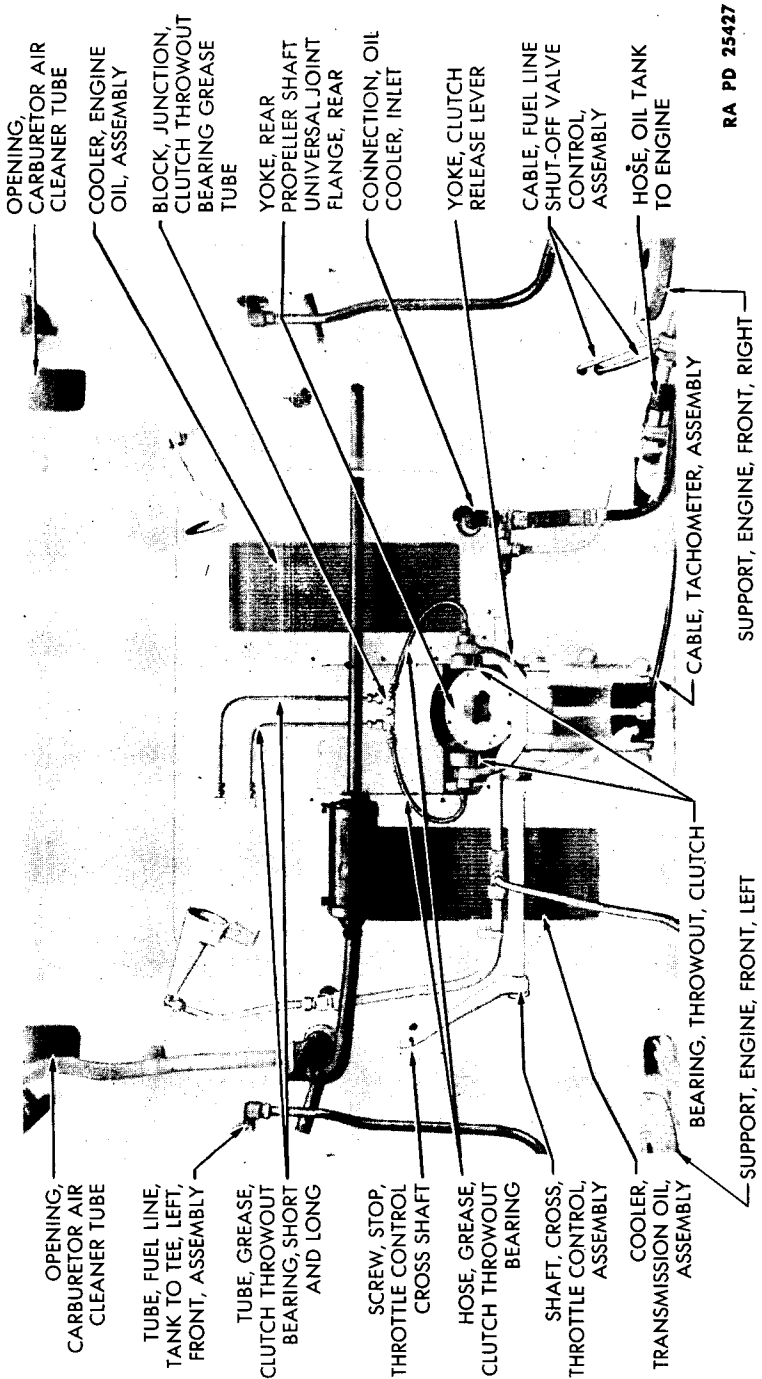
## POWER UNIT

- A**—BRACKET, ENGINE FRONT SUPPORT, LEFT
- B**—TUBE, FIRE EXTINGUISHER FLOOR ELBOW TO LEFT FLOOR TEE, ASSEMBLY
- C**—BRACKET, THROTTLE CONTROL CROSS SHAFT, LEFT, ASSEMBLY
- D**—CABLE, CHOKE CONTROL, ASSEMBLY
- E**—TUBE, OUTLET, FUEL TANK, LEFT, FRONT, ASSEMBLY
- F**—COOLER, OIL, TRANSMISSION, ASSEMBLY
- G**—SCREW, STOP, THROTTLE CONTROL CROSS SHAFT
- H**—TUBE, FIRE EXTINGUISHER BULKHEAD TEE TO LEFT FRONT TEE, ASSEMBLY
- I**—SCREEN, AUXILIARY GENERATOR EXHAUST
- J**—CABLE AND CONDUIT, BATTERY BOX TO ENGINE HARNESS CONNECTOR, ASSEMBLY
- K**—CABLE AND CONDUIT, STARTER AND GENERATOR, ASSEMBLY
- L**—NOZZLE, FIRE EXTINGUISHER TUBE, LEFT, FRONT
- M**—TUBE, AUXILIARY GENERATOR MUFFLER OUTLET, W/ELBOW, ASSEMBLY
- N**—CONDUIT, IGNITION COIL MAINFEED CABLE
- O**—OPENING, CARBURETOR AIR CLEANER
- P**—CONDUIT, FUEL GAGE, TAIL AND STOP LIGHT CABLES
- Q**—NOZZLE, FIRE EXTINGUISHER TUBE, RIGHT, FRONT
- R**—OPENING, CARBURETOR AIR CLEANER
- S**—TUBE, ENGINE OIL COOLER TO OIL AIR REMOVER TUBE, ASSEMBLY
- T**—TUBE, FIRE EXTINGUISHER RIGHT FRONT TEE TO NOZZLE, ASSEMBLY
- U**—COOLER, OIL, ENGINE, ASSEMBLY
- V**—TUBE, HOSE, OIL TANK TO AIR VENT TUBE
- W**—YOKE, REAR PROPELLER SHAFT UNIVERSAL JOINT FLANGE, REAR
- X**—BEARING, THROWOUT, CLUTCH
- Y**—TUBE, OUTLET, FUEL TANK, RIGHT, FRONT, ASSEMBLY
- Z**—CONNECTOR, OIL COOLER TO RADIATOR OIL HOSE
- AA**—HOPPER, OIL TANK ASSEMBLY
- BB**—YOKE, CLUTCH RELEASE LEVER
- CC**—WIRE, CONTROL, FUEL LINE SHUT-OFF VALVE, RIGHT, ASSEMBLY
- DD**—CONNECTION, OIL TANK TO RADIATOR OIL HOSE
- EE**—CABLE, TACHOMETER, ASSEMBLY
- FF**—WIRE, CONTROL, FUEL LINE SHUT-OFF VALVE, LEFT, ASSEMBLY

RA PD 25348B

Legend For Figure 14 — Power Unit Compartment Used With M3A4 Power Unit

ORDNANCE MAINTENANCE – POWER UNIT FOR MEDIUM TANKS M3A4 AND M4A4



OPENING, CARBURETOR AIR CLEANER TUBE

COOLER, ENGINE OIL, ASSEMBLY

BLOCK, JUNCTION, CLUTCH THROWOUT BEARING GREASE TUBE

YOKE, REAR PROPELLER SHAFT UNIVERSAL JOINT FLANGE, REAR

CONNECTION, OIL COOLER, INLET

YOKE, CLUTCH RELEASE LEVER

CABLE, FUEL LINE SHUT-OFF VALVE CONTROL, ASSEMBLY

HOSE, OIL TANK TO ENGINE

OPENING, CARBURETOR AIR CLEANER TUBE

TUBE, FUEL LINE, TANK TO TEE, LEFT, FRONT, ASSEMBLY

TUBE, GREASE, CLUTCH THROWOUT BEARING, SHORT AND LONG

SCREW, STOP, THROTTLE CONTROL CROSS SHAFT

HOSE, GREASE, CLUTCH THROWOUT BEARING

SHAFT, CROSS, THROTTLE CONTROL, ASSEMBLY

COOLER, TRANSMISSION OIL, ASSEMBLY

CABLE, TACHOMETER, ASSEMBLY

SUPPORT, ENGINE, FRONT, RIGHT

BEARING, THROWOUT, CLUTCH

SUPPORT, ENGINE, FRONT, LEFT

RA PD 25427

Figure 15 – Power Unit Compartment Used With M4A4 Power Unit

## POWER UNIT

hub being keyed to the camshaft. A gear bolted to the camshaft gear drives the ignition distributor. On No. 1 engine only, this same gear also drives the tachometer drive shaft and on No. 4 engine only (on power units equipped with single water pump), it drives the fuel pump. The crankshaft gear is keyed direct to the crankshaft.

(b) The timing gears are lubricated, under pressure, by a tube which supplies oil to the gear teeth (fig. 105).

(c) The timing gears are protected by a cast-iron timing gear case cover which is mounted on the cylinder block. A gasket between cover and cylinder block prevents oil leakage between cover and cylinder block. An oil retainer, mounted in the opening in cover, through which the crankshaft protrudes, prevents oil leakage between crankshaft and cover.

### (7) VALVE MECHANISM (figs. 20 and 94).

(a) *General.* The valve mechanism consists of the valve, valve guide, valve spring, valve spring retainer, valve spring retainer locks, and valve tappet.

(b) *Intake Valve.* The intake valves are nickel chromium steel forgings. The valves are ground to their seats, and the seats machined in the cylinder block. The valves operate in valve guides which are of the removable type and of gray-iron construction. The valves are held in position by split-cone valve spring seat locks.

(c) *Exhaust Valve.* The exhaust valves are silchrome steel forgings. They operate in valve guides which are of the removable type and of gray-iron construction. The valves rest on hardened steel inserts which are recessed into the cylinder block. These inserts are removable. The exhaust valves differ from the inlet valves in that the head on the exhaust valve is smaller in diameter. The valves are held in position by split-cone valve spring seat locks.

(d) *Valve Springs.* The valve springs are made of steel spring wire. The upper end of the springs fit into a recess in the cylinder block (fig. 94), the lower end resting on a retainer. The retainer is held in position by split-cone valve spring seat locks. The coils of the spring at one end are closer together and are installed in the cylinder block with these close coils at the top to insure proper dissipation of heat and to prevent valve clatter or flutter.

(e) *Valve Tappet Assembly.* The valve tappets consist of a push rod with a self-locking tappet adjusting screw in the upper end to provide adjustment of the assembly and to control clearance between the valve

ORDNANCE MAINTENANCE — POWER UNIT FOR  
MEDIUM TANKS M3A4 AND M4A4

RA PD 24522

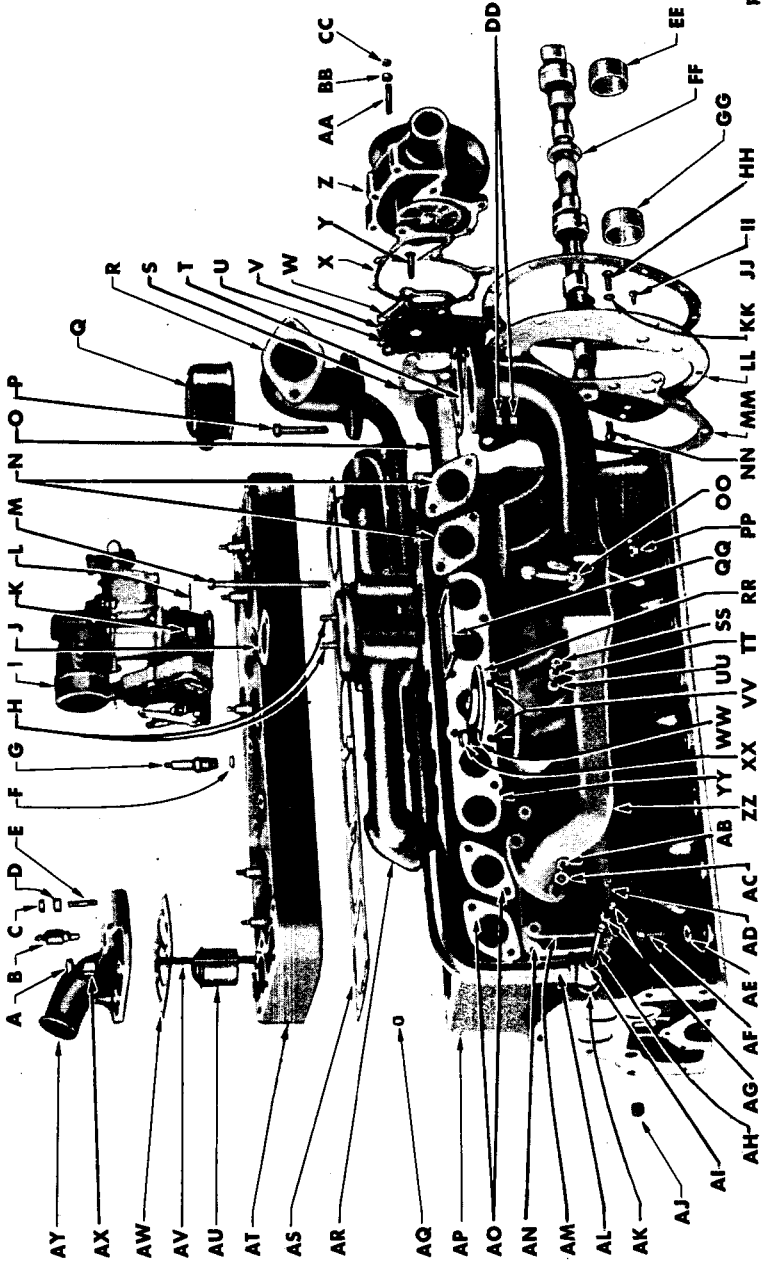


Figure 16 — No. 1 Engine (Multiple Water Pump Type), Partially Exploded

POWER UNIT

- A—NUT, LOCK, CYLINDER HEAD STUD NUT  
 B—UNIT, SENDING, ENGINE WATER TEMPERATURE, WARNING INDICATOR, ASSEMBLY  
 C—NUT, LOCK, CYLINDER HEAD ADAPTER STUD NUT  
 D—NUT, CYLINDER HEAD ADAPTER STUD  
 E—STUD, CYLINDER HEAD ADAPTER  
 F—GASKET, SPARK PLUG  
 G—PLUG, SPARK, ASSEMBLY  
 H—STUD, ATTACHING, CARBURETOR  
 I—CARBURETOR, ASSEMBLY  
 J—GASKET, CARBURETOR FLANGE  
 K—NUT, CARBURETOR ATTACHING STUD  
 L—WIRE, LOCK, CARBURETOR ATTACHING STUD NUT  
 M—BOLT, INTAKE TO EXHAUST MANIFOLD  
 N—GASKET, END, INTAKE AND EXHAUST MANIFOLD  
 O—TUBE, DISTRIBUTING, CYLINDER BLOCK WATER  
 P—BOLT, EXHAUST MANIFOLD ELBOW  
 Q—CLEANER, AIR, CRANKCASE VENTILATOR, ASSEMBLY  
 R—ELBOW, EXHAUST MANIFOLD  
 S—GASKET, WATER PUMP BODY TO CYLINDER BLOCK  
 T—GASKET, EXHAUST MANIFOLD ELBOW  
 U—SCREW, WATER PUMP BODY COVER PLATE  
 V—WASHER, LOCK, WATER PUMP BODY COVER PLATE SCREW  
 W—PLATE, COVER, WATER PUMP BODY  
 X—GASKET, WATER PUMP BODY COVER PLATE  
 Y—SCREW, WATER PUMP BODY COVER PLATE  
 Z—PUMP, WATER, ASSEMBLY  
 AA—STUD, WATER PUMP BODY  
 BB—NUT, WATER PUMP BODY STUD  
 CC—NUT, LOCK, WATER PUMP BODY STUD NUT  
 DD—NUT, EXHAUST MANIFOLD ELBOW BOLT  
 EE—BEARING, CAMSHAFT, NO. 2  
 FF—CAMSHAFT  
 GG—BEARING, CAMSHAFT, NO. 3  
 HH—SCREW, GEAR CASE COVER PLATE  
 II—SCREW, GEAR CASE COVER PLATE  
 JJ—GASKET, GEAR CASE COVER  
 KK—WASHER, LOCK, GEAR CASE COVER PLATE SCREW  
 LL—PLATE, GEAR CASE COVER, ASSEMBLY  
 MM—GASKET, GEAR CASE COVER PLATE  
 NN—BOLT, GEAR CASE COVER PLATE  
 OO—COUNTERWEIGHT, MANIFOLD HEAT CONTROL VALVE  
 PP—NUT, INTAKE TO EXHAUST MANIFOLD BOLT  
 QQ—GASKET, INTAKE TO EXHAUST MANIFOLD  
 RR—UNIT, SENDING, EXHAUST STACK TEMPERATURE WARNING INDICATOR, ASSEMBLY  
 SS—NUT, LOCK, EXHAUST MANIFOLD STUD NUT  
 TT—NUT, EXHAUST MANIFOLD STUD  
 UU—WASHER, CLAMP, MANIFOLD  
 VV—STUD, MOUNTING, EXHAUST STACK TEMPERATURE WARNING INDICATOR SENDING UNIT  
 WW—WASHER, EXHAUST STACK TEMPERATURE WARNING INDICATOR SENDING UNIT MOUNTING STUD  
 XX—NUT, EXHAUST STACK TEMPERATURE WARNING INDICATOR SENDING UNIT MOUNTING STUD  
 YY—GASKET, CENTER, INTAKE AND EXHAUST MANIFOLD  
 ZZ—MANIFOLD, EXHAUST  
 AB—NUT, LOCK, EXHAUST MANIFOLD STUD NUT  
 AC—NUT, EXHAUST MANIFOLD STUD  
 AD—WIRE, LOCK, VALVE SPRING COVER SCREW  
 AE—WASHER, LOCK, CYLINDER BLOCK TO CRANKCASE SCREW  
 AF—SCREW, CYLINDER BLOCK TO CRANKCASE  
 AG—SCREW, VALVE SPRING COVER, W/WASHER, ASSEMBLY  
 AH—SCREW, CRANKCASE VENTILATOR PIPE ELBOW  
 AI—GASKET, CRANKCASE VENTILATOR PIPE ELBOW SCREW  
 AJ—PLUG, OIL DISTRIBUTOR TUBE, FRONT  
 AK—GASKET, CRANKCASE VENTILATOR PIPE ELBOW  
 AL—PIPE, CRANKCASE VENTILATOR, ASSEMBLY  
 AM—COVER, VALVE SPRING  
 AN—GASKET, VALVE SPRING COVER  
 AO—GASKET, END, INTAKE AND EXHAUST MANIFOLD  
 AP—BLOCK, CYLINDER, ASSEMBLY  
 AQ—DOWEL, CYLINDER HEAD  
 AR—MANIFOLD, INTAKE  
 AS—GASKET, CYLINDER HEAD  
 AT—HEAD, CYLINDER  
 AU—THERMOSTAT, ASSEMBLY  
 AV—STUD, ATTACHING, CYLINDER HEAD  
 AW—GASKET, CYLINDER HEAD ADAPTER  
 AX—NUT, CYLINDER HEAD STUD  
 AY—ADAPTER, CYLINDER HEAD

RA PD 24522B

Legend For Figure 16 — No. 1 Engine (Multiple Water Pump Type), Partially Exploded





POWER UNIT

- A—VALVE, INTAKE
- B—VALVE, EXHAUST
- C—GUIDE, VALVE STEM
- D—SPRING, VALVE
- E—RETAINER, VALVE SPRING
- F—LOCK, VALVE SPRING RETAINER
- G—SCREW, ADJUSTING, VALVE TAPPET
- H—TAPPET, VALVE, ASSEMBLY
- I—KEY, CAMSHAFT GEAR HUB
- J—PLATE, THRUST, CAMSHAFT GEAR HUB
- K—HUB, CAMSHAFT GEAR
- L—RING, SNAP, CAMSHAFT GEAR HUB
- M—GEAR, CAMSHAFT
- N—GEAR, DISTRIBUTOR DRIVE
- O—WASHER, LOCK, CAMSHAFT GEAR SCREW
- P—PIN, GROOVE, TACHOMETER DRIVE SHAFT
- Q—GEAR, TACHOMETER DRIVE
- R—SUPPORT, TACHOMETER DRIVE GEAR
- S—KEY, TACHOMETER DRIVE GEAR SUPPORT
- T—GASKET, TACHOMETER DRIVE GEAR SUPPORT
- U—SHAFT, DRIVE, TACHOMETER
- V—COVER, GEAR CASE, ASSEMBLY
- W—WASHER, LOCK, TACHOMETER DRIVE NUT
- X—NUT, TACHOMETER DRIVE
- Y—INDICATOR, TIMING
- Z—WASHER, TIMING INDICATOR SCREW
- AA—SCREW, TIMING INDICATOR
- BB—COIL, IGNITION, ASSEMBLY
- CC—CABLES, IGNITION, W/TUBE, ASSEMBLY
- DD—BELT, WATER PUMP
- EE—STUD, MOUNTING, IGNITION DISTRIBUTOR
- FF—WASHER, IGNITION DISTRIBUTOR MOUNTING STUD NUT
- GG—NUT, IGNITION DISTRIBUTOR MOUNTING STUD
- HH—JAW, STARTING, CRANKSHAFT
- II—WASHER, LOCK, CRANKSHAFT STARTING JAW
- JJ—SCREW, VIBRATION DAMPER
- KK—DAMPER, VIBRATION, ASSEMBLY
- LL—PULLEY, DRIVE, WATER PUMP
- MM—CAP, IGNITION DISTRIBUTOR, ASSEMBLY
- NN—DISTRIBUTOR, IGNITION, ASSEMBLY
- OO—HUB, VIBRATION DAMPER
- PP—WASHER, GEAR CASE COVER DUST SEAL
- QQ—SCREW, GEAR CASE COVER
- RR—WASHER, LOCK, GEAR CASE COVER SCREW
- SS—NUT, LOCK, GEAR CASE COVER PLATE BOLT NUT
- TT—NUT, GEAR CASE COVER PLATE BOLT
- UU—SCREW, CAMSHAFT GEAR
- VV—GASKET, GEAR CASE COVER OIL SEAL
- WW—SEAL, OIL, GEAR CASE COVER, ASSEMBLY
- XX—SCREW, CAMSHAFT GEAR HUB THRUST PLATE
- YY—LOCK, CAMSHAFT GEAR HUB THRUST PLATE SCREW
- ZZ—WASHER, LOCK, CAMSHAFT GEAR OIL TUBE CLIP SCREW
- AB—SCREW, CAMSHAFT GEAR OIL TUBE CLIP
- AC—CLIP, CAMSHAFT GEAR OIL TUBE
- AD—TUBE, OIL, CAMSHAFT GEAR
- AE—BEARING, CAMSHAFT, NO. 1
- AF—CAMSHAFT

RA PD 24523B

Legend For Figure 17 — Engine Valve Mechanism, Gear Case And Attaching Parts  
(Multiple Water Pump Type), Partially Exploded

**ORDNANCE MAINTENANCE — POWER UNIT FOR  
MEDIUM TANKS M3A4 AND M4A4**

tappet and valve stem. The valve tappet is held in place in its guide by the camshaft. The lower end of the valve tappet is of the mushroom type.

**(8) PISTONS.**

(a) The pistons are aluminum alloy castings, completely machined on outside surfaces and are tin-plated to insure longer life. They are of the U-slot type, with the piston skirts slightly elliptical in shape. These features offset tendencies toward uneven expansion, so that the piston closely conforms to the cylinder walls when heated to operating temperatures.

(b) The piston pins are made from manganese steel. They float in the connecting rod bushing and in bosses in the pistons, and are held in place by a retaining ring at each end of the pin.

(c) Four piston rings are used on each piston, located above the piston pin. All rings are made of piston ring iron and all have square joints at ends of rings. The 2 upper rings are compression rings to prevent exhaust gases or fuel vapors from seeping down past the piston. The 2 lower rings are oil control rings which control the amount of oil that is left on the cylinder walls for lubricating walls and compression rings.

(9) **MANIFOLDS.** The intake and exhaust manifolds are mounted on the left side of the cylinder block as an assembly, with gaskets between the intake and exhaust manifolds and between the cylinder block and manifolds to prevent any exhaust leakage at the exhaust ports or any leakage at the inlet ports. They are secured to the cylinder blocks by 13 studs and nuts. Provision is made for heating the fuel before it enters the cylinder block by passing hot exhaust gases around the inlet opening of the intake manifold. This is controlled by a thermostatically controlled valve, this passage being open only when the engine is cold.

**8. TABULATED DATA AND SPECIFICATIONS.**

**a. Power Unit.**

Bore .....	3 <sup>7</sup> / <sub>16</sub> -in.
Stroke .....	4 1/2-in.
Compression ratio .....	6.2 to 1
Compression pressure (lb per sq in.) at cranking speed (110 rpm) .....	80 to 85 pounds
Cylinder head material.....	Cast iron
Firing order .....	See figure 156
Governed speed .....	3,100 rpm under no load

**POWER UNIT**

Horsepower (gross) .....	445 at 2,400 rpm
Make .....	Chrysler
Over-all length .....	54 1/8 in.
Over-all width .....	58 3/4 in.
Over-all height .....	56 1/2 in.
Piston displacement .....	1,253.0 cu in.
Rotation of engine drive gear shaft .....	Clockwise
Serial number location:	
Multiple water pump type .....	Distributor end of crankcase
Single water pump type .....	Power unit rear support
Speed of engine driven gear shaft (times crankshaft speed) .....	0.8395 to 1
Number of supports .....	3
Weight (with accessories) .....	5,375 lb

**b. Individual Engine.**

**(1) CAMSHAFT AND BEARINGS.**

**(a) Camshaft.**

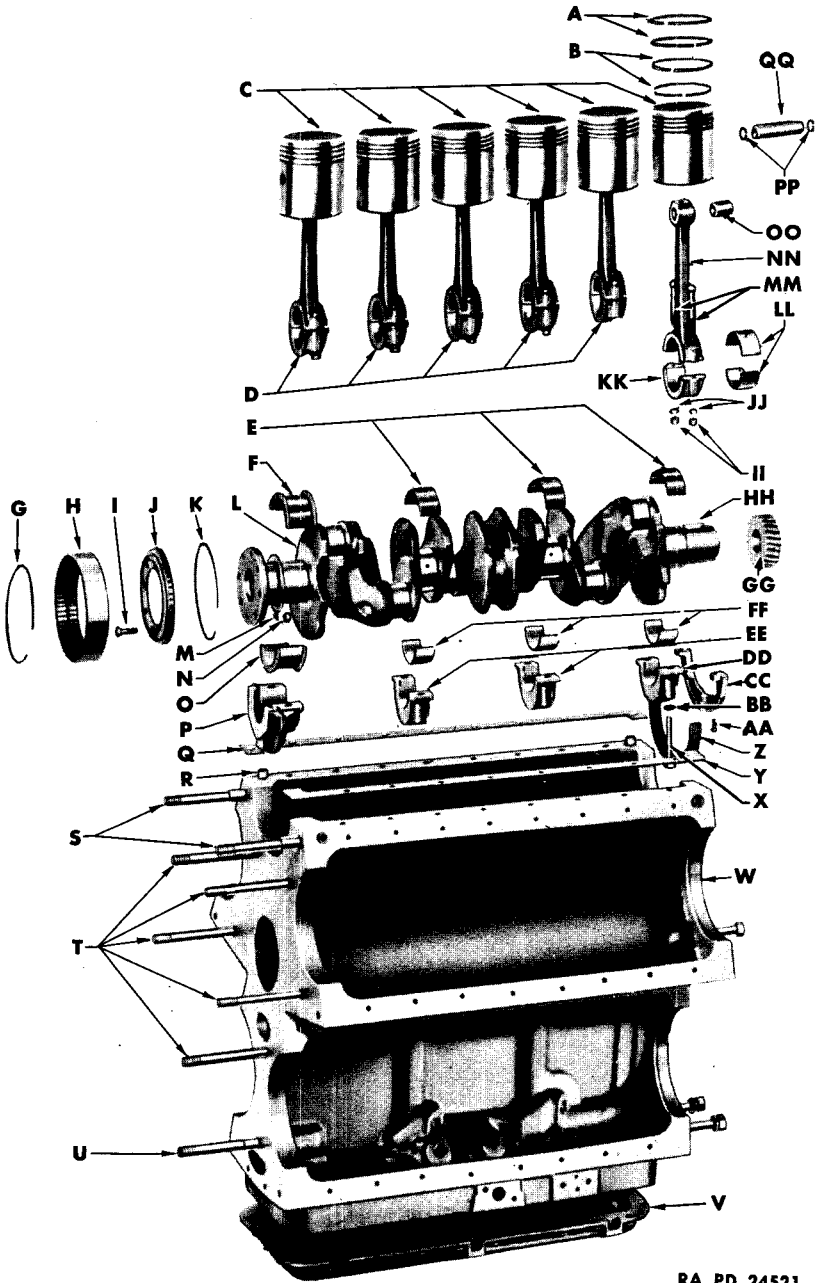
Drive .....	Gear
Journal diameters:	
No. 1 .....	1.998 in. to 1.999 in.
No. 2 .....	1.9665 in. to 1.9675 in.
No. 3 .....	1.935 in. to 1.936 in.
No. 4 .....	1.2475 in. to 1.2485 in.
Material .....	Cast iron

**(b) Bearings.**

**Diameter (inside):**

No. 1 .....	2.000 in. to 2.001 in.
No. 2 .....	1.969 in. to 1.970 in.
No. 3 .....	1.9375 in. to 1.9385 in.
No. 4 .....	1.250 in. to 1.251 in.
Type .....	Babbitt on steel (except No. 4 which is reamed in cast-iron cylinder block)

ORDNANCE MAINTENANCE — POWER UNIT FOR  
MEDIUM TANKS M3A4 AND M4A4



RA PD 24521

Figure 18 — Lower Part Of No. 1 Engine, Showing Crankcase In Position

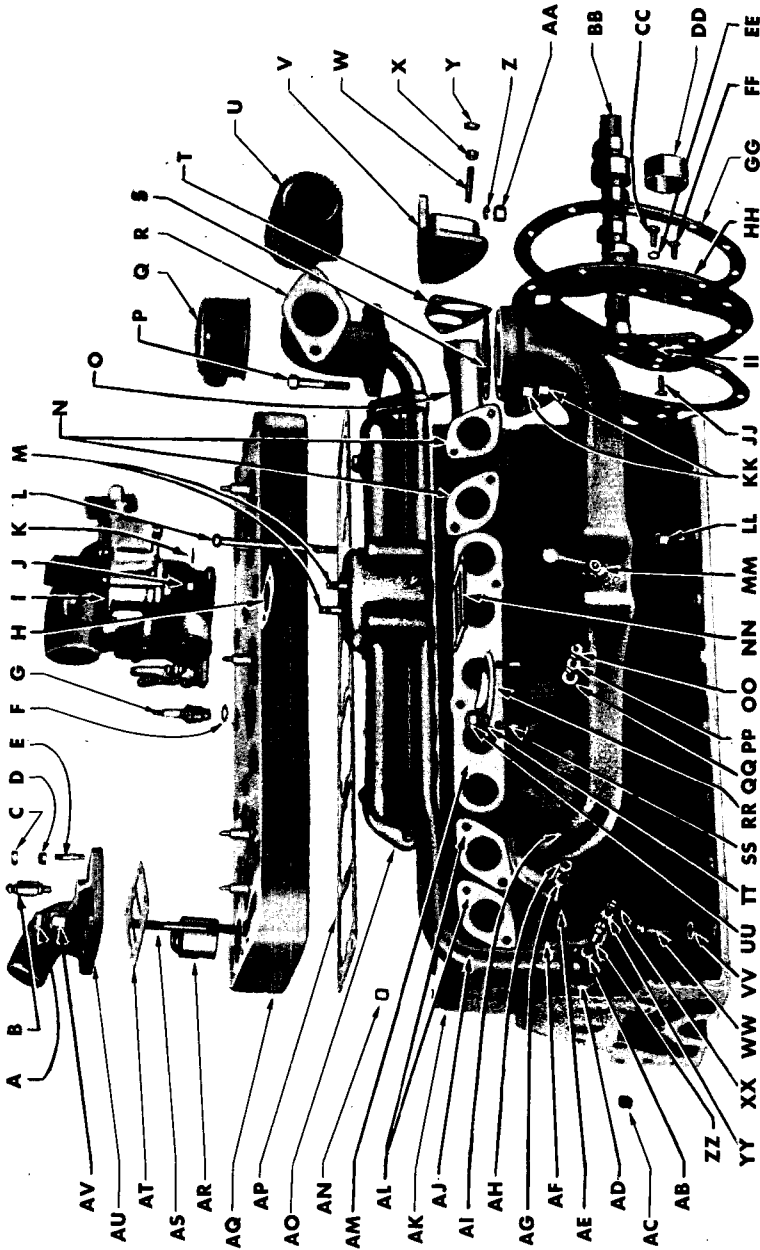
POWER UNIT

- A—RING, PISTON, UPPER
- B—RING, PISTON, LOWER
- C—PISTON
- D—ROD, CONNECTING, ASSEMBLY
- E—BEARING, CRANKSHAFT, UPPER (NOS. 1, 2, 3)
- F—BEARING, CRANKSHAFT, UPPER (NO. 4)
- G—RING, SNAP, ENGINE DRIVE GEAR CLUTCH SLEEVE
- H—SLEEVE, ENGINE DRIVE GEAR CLUTCH
- I—BOLT, ENGINE DRIVE GEAR CLUTCH
- J—CLUTCH, ENGINE DRIVE GEAR
- K—RING, SNAP, ENGINE DRIVE GEAR CLUTCH SLEEVE
- L—CRANKSHAFT
- M—WASHER, LOCK, ENGINE DRIVE GEAR, CLUTCH BOLT NUT
- N—NUT, ENGINE DRIVE GEAR CLUTCH BOLT
- O—BEARING, CRANKSHAFT, LOWER (NO. 4)
- P—CAP, CRANKSHAFT BEARING (NO. 4)
- Q—GASKET, CYLINDER BLOCK, RIGHT
- R—DOWEL, CYLINDER BLOCK TO CRANKCASE
- S—STUD, DOWEL ENGINE DRIVE GEAR HOUSING TO CRANKCASE, SHORT
- T—STUD, ENGINE DRIVE GEAR HOUSING TO CRANKCASE
- U—STUD, DOWEL ENGINE DRIVE GEAR HOUSING TO CRANKCASE, SHORT
- V—PAN, OIL, ASSEMBLY
- W—CRANKCASE, ASSEMBLY
- X—SCREW, CRANKSHAFT BEARING CAP
- Y—GASKET, CYLINDER BLOCK, LEFT
- Z—GASKET, CRANKCASE, REAR
- AA—SCREW, CRANKCASE OIL SEAL PLATE
- BB—WASHER, LOCK, CRANKSHAFT BEARING CAP SCREW
- CC—PLATE, CRANKCASE OIL SEAL
- DD—CAP, CRANKSHAFT BEARING (NO. 1)
- EE—CAP, CRANKSHAFT BEARING (NOS. 2, 3)
- FF—BEARING, CRANKSHAFT, LOWER (NOS. 1, 2, 3)
- GG—GEAR, CRANKSHAFT
- HH—KEY, CRANKSHAFT GEAR
- II—NUT, CONNECTING ROD CAP BOLT
- JJ—WASHER, LOCK, CONNECTING ROD CAP BOLT NUT
- KK—CAP, CONNECTING ROD BEARING
- LL—BEARING, CONNECTING ROD
- MM—BOLT, CONNECTING ROD BEARING CAP
- NN—ROD, CONNECTING
- OO—BUSHING, CONNECTING ROD
- PP—WIRE, LOCK, PISTON PIN
- QQ—PIN, PISTON

RA PD 24521B

**Legend For Figure 18 — Lower Part Of No. 1 Engine, Showing Crankcase In Position**

ORDNANCE MAINTENANCE — POWER UNIT FOR  
MEDIUM TANKS M3A4 AND M4A4



RA PD 24524

Figure 19 — No. 1 Engine (Single Water Pump Type), Partially Exploded

POWER UNIT

- A—NUT, LOCK, CYLINDER HEAD STUD NUT
- B—UNIT, SENDING, ENGINE WATER TEMPERATURE WARNING INDICATOR
- C—NUT, LOCK, CYLINDER HEAD ADAPTER STUD NUT
- D—NUT, CYLINDER HEAD ADAPTER STUD
- E—STUD, CYLINDER HEAD ADAPTER
- F—GASKET, SPARK PLUG
- G—PLUG, SPARK, ASSEMBLY
- H—GASKET, CARBURETOR FLANGE
- I—CARBURETOR, ASSEMBLY
- J—NUT, CARBURETOR ATTACHING STUD
- K—WIRE, LOCK, CARBURETOR ATTACHING STUD NUT
- L—BOLT, INTAKE TO EXHAUST MANIFOLD
- M—STUD, ATTACHING, CARBURETOR
- N—GASKET, END, INTAKE AND EXHAUST MANIFOLD
- O—TUBE, DISTRIBUTING, CYLINDER BLOCK WATER
- P—BOLT, EXHAUST MANIFOLD ELBOW
- Q—CLEANER, AIR, CRANKCASE VENTILATOR, ASSEMBLY
- R—ELBOW, EXHAUST MANIFOLD
- S—GASKET, EXHAUST MANIFOLD ELBOW
- T—GASKET, WATER PUMP OUTLET TUBE ADAPTER
- U—COIL, IGNITION, ASSEMBLY
- V—ADAPTER, WATER PUMP OUTLET TUBE
- W—STUD, WATER PUMP OUTLET TUBE ADAPTER
- X—NUT, WATER PUMP OUTLET TUBE ADAPTER STUD
- Y—NUT, LOCK, WATER PUMP OUTLET TUBE ADAPTER STUD NUT
- Z—WASHER, LOCK, IGNITION COIL MOUNTING STUD NUT
- AA—NUT, IGNITION COIL MOUNTING STUD
- BB—CAMSHAFT
- CC—SCREW, GEAR CASE COVER PLATE
- DD—BEARING, CAMSHAFT, NO. 3
- EE—WASHER, LOCK, GEAR CASE COVER PLATE SCREW
- FF—SCREW, GEAR CASE COVER PLATE
- GG—GASKET, GEAR CASE COVER
- HH—PLATE, GEAR CASE COVER, ASSEMBLY
- II—GASKET, GEAR CASE COVER PLATE
- JJ—BOLT, GEAR CASE COVER PLATE
- KK—NUT, EXHAUST MANIFOLD ELBOW BOLT
- LL—NUT, INTAKE TO EXHAUST MANIFOLD BOLT
- MM—COUNTERWEIGHT, MANIFOLD HEAT CONTROL VALVE
- NN—GASKET, INTAKE TO EXHAUST MANIFOLD
- OO—NUT, LOCK, EXHAUST MANIFOLD STUD NUT
- PP—NUT, EXHAUST MANIFOLD STUD
- QQ—WASHER, CLAMP, MANIFOLD
- RR—UNIT, SENDING, EXHAUST STACK TEMPERATURE WARNING INDICATOR, ASSEMBLY
- SS—STUD, MOUNTING, EXHAUST STACK TEMPERATURE WARNING INDICATOR SENDING UNIT
- TT—WASHER, LOCK, EXHAUST STACK TEMPERATURE WARNING INDICATOR SENDING UNIT MOUNTING STUD NUT
- UU—NUT, EXHAUST STACK TEMPERATURE WARNING INDICATOR SENDING UNIT MOUNTING STUD
- VV—WASHER, LOCK, CYLINDER BLOCK TO CRANKCASE SCREW
- WW—SCREW, CYLINDER BLOCK TO CRANKCASE
- XX—WIRE, LOCK, VALVE SPRING COVER SCREW
- YY—SCREW, VALVE SPRING COVER, W/WASHER ASSEMBLY
- ZZ—SCREW, CRANKCASE VENTILATOR PIPE ELBOW
- AB—GASKET, CRANKCASE VENTILATOR PIPE ELBOW SCREW
- AC—PLUG, OIL DISTRIBUTOR TUBE, FRONT
- AD—GASKET, CRANKCASE VENTILATOR PIPE ELBOW
- AE—COVER, VALVE SPRING
- AF—GASKET, VALVE SPRING COVER
- AG—NUT, EXHAUST MANIFOLD STUD
- AH—NUT, LOCK, EXHAUST MANIFOLD STUD NUT
- AI—MANIFOLD, EXHAUST
- AJ—PIPE, CRANKCASE VENTILATOR, ASSEMBLY
- AK—BLOCK, CYLINDER, ASSEMBLY
- AL—GASKET, END, INTAKE AND EXHAUST MANIFOLD
- AM—GASKET, CENTER, INTAKE AND EXHAUST MANIFOLD
- AN—DOWEL, CYLINDER HEAD
- AO—MANIFOLD, INTAKE
- AP—GASKET, CYLINDER HEAD
- AQ—HEAD, CYLINDER
- AR—THERMOSTAT, ASSEMBLY
- AS—STUD, ATTACHING, CYLINDER HEAD
- AT—GASKET, CYLINDER HEAD ADAPTER
- AU—ADAPTER, CYLINDER HEAD
- AV—NUT, CYLINDER HEAD STUD

RA PD 24524B

Legend For Figure 19 — No. 1 Engine (Single Water Pump Type) Partially Exploded



**ORDNANCE MAINTENANCE — POWER UNIT FOR  
MEDIUM TANKS M3A4 AND M4A4**

**(2) CYLINDER BLOCK.**

Bore size ..... 3.4375 in. to 3.4395 in. in 0.0005 steps,  
lettered "A" to "E"  
Material ..... Gray iron

**(3) PISTON AND PISTON RINGS.**

*(a) Pistons.*

Diameter, standard ..... 3.4352 in. to 3.4357 in.  
Length ..... 3<sup>7</sup>/<sub>8</sub>-in.  
Material ..... Aluminum alloy  
Ring groove width:  
Top groove ..... 0.096 in. to 0.097 in.  
No. 2 groove ..... 0.0955 in. to 0.0965 in.  
No. 3 groove ..... 0.156 in. to 0.157 in.  
No. 4 groove ..... 0.156 in. to 0.157 in.  
Type ..... U-slot

*(b) Rings.*

Compression:

Number used per piston ..... 2  
Width ..... 0.0930 in. to 0.0935 in.

Oil:

Number used per piston ..... 2  
Width ..... 0.1545 in. to 0.1550 in.

**(4) CONNECTING RODS AND PISTON PINS.**

*(a) Connecting Rods.*

Bearing material ..... Babbitt on steel  
Bearing type ..... Interchangeable thin shells  
Length, center to center ..... 7<sup>7</sup>/<sub>8</sub>-in.  
Rod type ..... Drop forged "I" section, 2 bolt  
Crankpin journal:  
Diameter ..... 2.1236 in. to 2.1246 in.  
Length ..... 1.373 in. to 1.377 in.

**POWER UNIT**

*(b) Piston Pins.*

Diameter ..... 0.8591 in. to 0.8593 in.  
 Hole finish ..... Diamond bore  
 Length ..... 2.863 in. to 2.878 in.  
 Type ..... Full floating

**(5) CRANKSHAFTS.**

Number of counterweights ..... 9 - integral  
 Direction of rotation ..... Counterclockwise  
 End thrust, taken by ..... No. 4 bearing  
 Material ..... Drop-forged steel

**Journal dimensions:**

**No. 1**

Diameter ..... 2.4992 in. to 2.5002 in.  
 Length ..... 1.4355 in. to 1.4395 in.

**No. 2**

Diameter ..... 2.4992 in. to 2.5002 in.  
 Length ..... 1.4355 in. to 1.4395 in.

**No. 3**

Diameter ..... 2.4992 in. to 2.5002 in.  
 Length ..... 1.4355 in. to 1.4395 in.

**No. 4**

Diameter ..... 2.4992 in. to 2.5002 in.  
 Length ..... 1.874 in. to 1.876 in.

**Main bearings:**

Material ..... Steel-backed, babbitt  
 Type ..... Interchangeable thin shells

**(6) TIMING GEARS.**

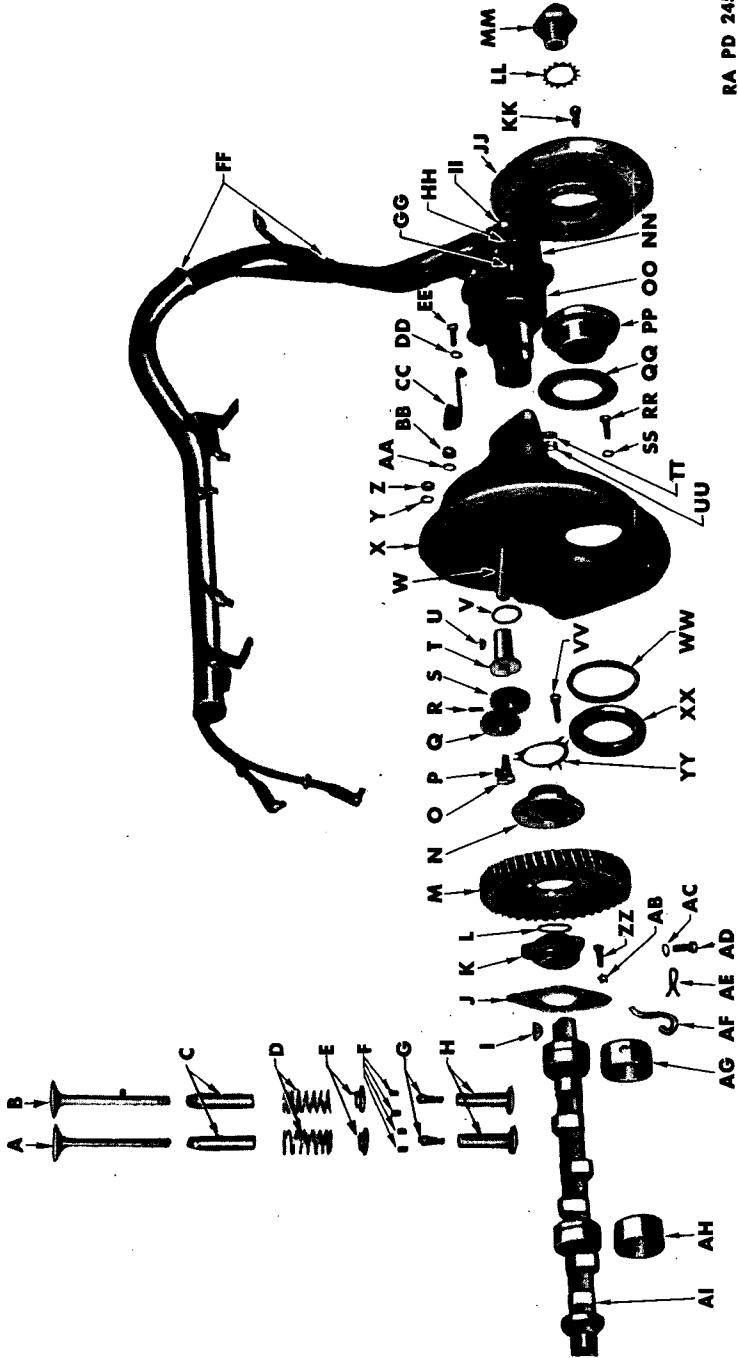
**Crankshaft gear:**

Number of teeth ..... 24

**Camshaft gear:**

Number of teeth ..... 48

ORDNANCE MAINTENANCE — POWER UNIT FOR  
MEDIUM TANKS M3A4 AND M4A4



RA PD 24525

Figure 20 — Engine Valve Mechanism, Gear Case And Attaching Parts  
(Single Water Pump Type), Partially Exploded

POWER UNIT

- A—VALVE, INTAKE
- B—VALVE, EXHAUST
- C—GUIDE, VALVE STEM
- D—SPRING, VALVE
- E—RETAINER, VALVE SPRING
- F—LOCK, VALVE SPRING RETAINER
- G—SCREW, ADJUSTING, VALVE TAPPET
- H—TAPPET, VALVE ASSEMBLY
- I—KEY, CAMSHAFT GEAR HUB
- J—PLATE, THRUST, CAMSHAFT GEAR HUB
- K—HUB, CAMSHAFT GEAR
- L—RING, SNAP, CAMSHAFT GEAR HUB
- M—GEAR, CAMSHAFT
- N—GEAR, DISTRIBUTOR DRIVE
- O—SHAFT, TACHOMETER IDLER GEAR
- P—KEY, TACHOMETER IDLER GEAR SHAFT
- Q—GEAR, IDLER, TACHOMETER
- R—PIN, TACHOMETER DRIVE GEAR
- S—GEAR, TACHOMETER DRIVE
- T—SUPPORT, TACHOMETER DRIVE GEAR
- U—KEY, TACHOMETER DRIVE GEAR SUPPORT
- V—GASKET, TACHOMETER DRIVE GEAR SUPPORT
- W—SHAFT, DRIVE, TACHOMETER
- X—COVER, GEAR CASE, ASSEMBLY
- Y—WASHER, LOCK TACHOMETER IDLER GEAR SHAFT
- Z—NUT, TACHOMETER IDLER GEAR SHAFT
- AA—WASHER, LOCK, TACHOMETER DRIVE NUT
- BB—NUT, TACHOMETER DRIVE
- CC—INDICATOR, TIMING
- DD—WASHER, TIMING INDICATOR SCREW
- EE—SCREW, TIMING INDICATOR
- FF—CABLES, IGNITION, W/TUBE, ASSEMBLY
- GG—STUD, MOUNTING, IGNITION DISTRIBUTOR
- HH—WASHER, IGNITION/DISTRIBUTOR MOUNTING STUD NUT
- II—NUT, IGNITION DISTRIBUTOR MOUNTING STUD
- JJ—DAMPER, VIBRATION, ASSEMBLY
- KK—SCREW, VIBRATION DAMPER
- LL—WASHER, LOCK, CRANKSHAFT STARTING JAW
- MM—JAW, STARTING CRANKSHAFT
- NN—CAP, IGNITION DISTRIBUTOR, ASSEMBLY
- OO—DISTRIBUTOR, IGNITION, ASSEMBLY
- PP—HUB, VIBRATION DAMPER
- QQ—WASHER, GEAR CASE COVER DUST SEAL
- RR—SCREW, GEAR CASE COVER
- SS—WASHER, LOCK, GEAR CASE COVER SCREW
- TT—NUT, LOCK, GEAR CASE COVER BOLT NUT
- UU—NUT, GEAR CASE COVER BOLT
- VV—SCREW, CAMSHAFT GEAR
- WW—GASKET, GEAR CASE COVER OIL SEAL
- XX—SEAL, OIL, GEAR CASE COVER, ASSEMBLY
- YY—WASHER, LOCK, CAMSHAFT GEAR SCREW
- ZZ—SCREW, CAMSHAFT GEAR HUB THRUST PLATE
- AB—LOCK, CAMSHAFT GEAR HUB THRUST PLATE SCREW
- AC—WASHER, LOCK, CAMSHAFT GEAR OIL TUBE CLIP SCREW
- AD—SCREW, CAMSHAFT GEAR OIL TUBE CLIP
- AE—CLIP, CAMSHAFT GEAR OIL TUBE
- AF—TUBE, OIL, CAMSHAFT GEAR
- AG—BEARING, CAMSHAFT, NO. 1
- AH—BEARING, CAMSHAFT, NO. 2
- AI—CAMSHAFT

RA PD 24525B

Legend For Figure 20 — Engine Valve Mechanism, Gear Case And Attaching Parts (Single Water Pump Type), Partially Exploded

ORDNANCE MAINTENANCE — POWER UNIT FOR  
MEDIUM TANKS M3A4 AND M4A4

(7) VALVES, VALVE SPRINGS, AND TAPPETS.

(a) Valves.

Arrangement .....	L-head
Guide .....	Removable, 1 piece, gray iron
Head diameter, exhaust .....	1.531 in.
Head diameter, intake .....	1.718 in.
Lift, exhaust .....	0.365 in.
Lift, inlet .....	0.365 in.
Seat angle, exhaust and intake .....	45 degrees
Stem diameter, exhaust .....	0.3385 in. to 0.3395 in.
Stem diameter, intake .....	0.3404 in. to 0.3415 in.
Ream all guides to .....	0.3425 in. to 0.3435 in.
Stem length, exhaust .....	4 <sup>27</sup> / <sub>32</sub> in.
Stem length, intake .....	4 <sup>27</sup> / <sub>32</sub> in.
Type of head .....	Integral with stem

(b) Valve Springs.

Material .....	Steel spring wire, cadmium plated
Number of coils .....	8 <sup>1</sup> / <sub>4</sub>
Spring pressure, valve open, with 1 <sup>3</sup> / <sub>8</sub> in. spring length .....	107 lb to 115 lb
Spring pressure, valve closed, with 1 <sup>3</sup> / <sub>4</sub> in. spring length .....	40 lb to 45 lb

(c) Tappets.

Head diameter .....	1.280 in. to 1.295 in.
Stem diameter .....	0.6235 in. to 0.6240 in.
Type .....	Mushroom
Tappet wrench size .....	1/2 in.
Tappet adjusting screw wrench size .....	7/8 in.

(8) VALVE TIMING.

Inlet valve opens .....	12 deg before T.D.C.
Inlet valve closes .....	44 deg after B.D.C.

POWER UNIT

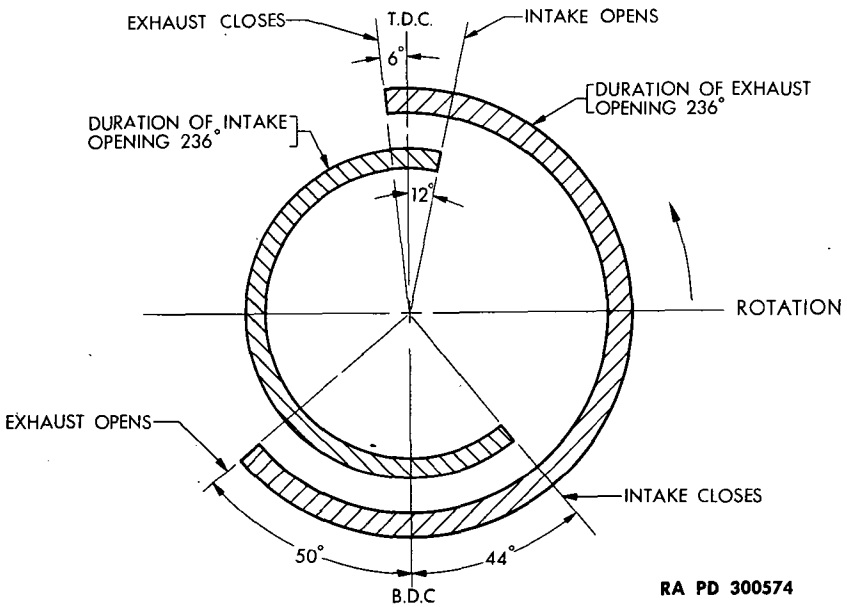


Figure 21 — Valve Timing Diagram From Distributor End

Exhaust valve opens.....	50 deg before B.D.C.
Exhaust valve closes.....	6 deg after T.D.C.
Valve port diameter, inlet .....	1 <sup>9</sup> / <sub>16</sub> in.
Valve port diameter, exhaust .....	1 <sup>3</sup> / <sub>8</sub> in.

9. SECOND ECHELON OPERATIONS.

a. In view of the fact that many second echelon operations described in TM 9-754 are often performed by ordnance maintenance personnel, the information is not repeated in this manual; therefore ordnance maintenance personnel should refer to TM 9-754 for this information. It will be noted that reference is made to the technical manual previously mentioned, where this applies.

10. ORGANIZATION MAINTENANCE.

a. Refer to paragraph 4.

ORDNANCE MAINTENANCE — POWER UNIT FOR  
MEDIUM TANKS M3A4 AND M4A4

Section II

**TROUBLE SHOOTING**

	Paragraph
General .....	11
Trouble shooting (power unit assembly) .....	12
Trouble shooting (individual engine) .....	13

**11. GENERAL**

a. The following outline will assist in diagnosing troubles which may be encountered with the power unit. When trouble shooting, first turn to the group pertaining to the condition at hand and perform the tests outlined in the group. As a means of simplification, conditions pertaining to the power unit as an assembly are listed in paragraph 12, while conditions pertaining to any one of the five individual engines are listed in paragraph 13.

**12. TROUBLE SHOOTING (POWER UNIT ASSEMBLY).**

**a. Starting Motor Does Not Turn Power Unit.**

Probable Cause	Probable Remedy
Battery discharge.	Replace or recharge battery.
Battery and/or starter terminals loose and dirty.	Clean, tighten, or replace terminals.
Incorrect grade of oil.	Drain and refill with proper grade of oil. If outside air temperature is below +32 F, use OIL, engine, SAE 10.
Power unit "seized."	Check oil and water. Allow power unit to cool (if water temperature gage reading is excessive); then try starter. If resistance to starter is noted, remove power unit air inlet grill and turn power unit fan in reverse direction (clockwise from fan end) one complete turn to expel any fuel from engines.
Starter switch defective.	Repair or replace switch.

**TROUBLE SHOOTING**

Probable Cause	Probable Remedy
Starter inoperative.	Repair or replace starter.
Starter drive bent or locked.	Repair or replace starter.
Starter solenoid switch inoperative.	Repair or replace solenoid switch.
Ice frozen in fan shroud below fan.	Remove ice.
 <b>b. Power Unit Turns But Will Not Start.</b>	
Lack of fuel.	Check supply of fuel in tanks. Check and open fuel shutoff valves. Check solenoid fuel shutoff valve for operation. Also check wires to solenoid fuel shutoff valve and correct if necessary. Operate valve manually by raising small disk at bottom of valve.
Fuel filter leaking or clogged.	Tighten connections or clean filter.
Fuel pump inoperative.	Repair or replace.
Fuel line broken or leaking.	Repair or replace.
Fuel pump inlet line plugged.	Disconnect at fuel pump and clean.
Fuel line plugged at distributor block.	Disconnect line at block and fuel pump and blow-out line with compressed air.
Water in fuel.	Drain tanks and refill with clean fuel.
Poor contact at ignition switch.	Repair or replace switch.
Feed wire from ignition switch to ignition solenoid switch, or to ignition filter and to ignition coils, loose or broken.	Tighten connections or replace wire.
Starter turns power unit too slowly.	Replace or recharge battery. Change power unit oil to proper grade. (If outside air temperature is below +32 F, use OIL, engine, SAE 10.
Accumulation of moisture, dirt or oil on distributor cap, coil tower or spark plugs.	Clean.



**ORDNANCE MAINTENANCE – POWER UNIT FOR  
MEDIUM TANKS M3A4 AND M4A4**

Probable Cause	Probable Remedy
Pitted or dirty distributor points.	Clean or replace and reset.
Burned distributor points.	Replace points and condenser.
Carburetors flooded.	Hold accelerator wide open while cranking power unit whenever flooding is suspected.
Carburetor choke levers improperly set.	Set choke levers for prevailing power unit temperature.
Ignition coil or coils defective.	Replace.

**c. Power Unit Runs But Lacks Power.**

Ignition timing late.	Reset.
Power unit overheats.	See subparagraph e, below.
One or more engines running too cold.	Check exhaust stack warning lights and investigate cause in engines indicated. Check water temperature reading on all engines.
Faulty spark plugs.	Clean and adjust or replace.
Incorrect governor setting or operation.	Investigate and correct.

**d. Power Unit Operates Unevenly.**

Ignition coil wires (primary or high tension) broken or loose.	Tighten or replace as necessary.
Accumulation of moisture (dirt or oil) on distributor cap, coil tower or spark plugs.	Clean.

**e. Power Unit Overheats.**

Coolant level low.	Replenish coolant and check all water connections for leaks. <b>CAUTION:</b> When removing filler cap, loosen lock nut holding cap in place and allow pressure to escape before the cap is free to open, otherwise there is a possibility of serious personal injury.
--------------------	---

## TROUBLE SHOOTING

Probable Cause	Probable Remedy
Water pump drive belt loose or broken (multiple water pump type).	Adjust or replace belt.
Low oil supply.	Replenish oil supply.
Ignition timing late.	Reset.
Insufficient air to radiator.	Remove any obstruction from top of air inlet grill. Remove any accumulation of dirt from outside surface of radiator.
Collapsed or obstructed water hose.	Replace hose
 <b>f. Power Unit Stops.</b>	
Lack of fuel.	Replenish fuel supply, open fuel shut-off valves or remove obstruction. Check solenoid fuel shutoff valve wires and connect or tighten.
Ignition wires loose or broken.	Check wiring, tighten connections, or replace as necessary.
 <b>g. Pops Back Through Carburetor Or Out The Exhaust</b>	
Dirt in fuel lines or carburetors.	Remove, clean, and install.
Carburetor flooding.	Repair or replace.
Faulty fuel pump.	Replace.
Incorrect ignition timing.	Reset.
Burned distributor points.	Replace.
Crossed spark plug wires.	Check and connect correctly.
Leaking valves.	Grind or replace.
 <b>h. Water Temperature Gage Reads "HIGH."</b>	
Coolant level low.	Check and replenish, as necessary.
Power unit air inlet obstructed.	Remove obstruction.
Water pump drive belt broken or slipping.	Adjust, or replace, as necessary.

**ORDNANCE MAINTENANCE — POWER UNIT FOR  
MEDIUM TANKS M3A4 AND M4A4**

<b>Probable Cause</b>	<b>Probable Remedy</b>
Outside surface of radiator dirty.	Remove dirt.
Coolant frozen.	Remove ice.
Water tubes obstructed.	Remove obstruction.
Ignition timing late.	Reset.
Thermostat installed upside down.	Install correctly.
Fuel filter obstructed.	Remove and clean.
Water pump air relief tube obstructed (multiple water pump type only).	Remove obstruction.
Panel gage or sending unit not operating properly.	Check and replace unit, as necessary.

**i. Water Temperature Gage Reads "LOW."**

Thermostats defective.	Replace.
Panel gage or sending unit not operating properly.	Check and replace unit, as necessary.

**j. High Water Temperature Warning Light Comes On.**

**NOTE:** If temperature of any one engine exceeds 225 F, check items in subparagraph h, above. If temperatures of all engines are less than 225 F, check sending units and circuit. To check bulb operation in high water temperature warning signal, push in on handle of water temperature gage selector switch.

**k. Power Unit Misses At Low Speed.**

One or more spark plugs not operating.	Replace.
Ignition distributor points burned or improperly spaced.	Adjust or replace, as necessary.
Valve burned or sticking.	Free up or reseat, as necessary.
Broken piston.	Replace.
Cylinder head gasket blown.	Replace.

## TROUBLE SHOOTING

Probable Cause	Probable Remedy
Low compression pressure.	Check compression pressures; reading should be 90 pounds to 115 pounds per square inch at cranking speed.
Manifold heat control valves not operating properly.	Free up, as necessary.

### l. No Oil Pressure Indicated On Oil Pressure Gage.

Low oil level.	Check and replenish, as necessary.
Panel gage not operating properly.	Check with a reliable gage in oil gallery. This pressure should be between 25 pounds and 60 pounds per square inch at idling speed (750 rpm) and 40 pounds to 70 pounds per square inch at 3,000 rpm when oil temperature is 160 F.
Oil leaks or restricted oil suction line.	Check and correct, as necessary.
Oil pressure gage or sending unit not operating properly.	Check and replace, as necessary.
Oil pressure pump not operating.	Repair or replace.

### m. Low Oil Pressure Warning Indicator Indicates Trouble.

NOTE: If oil pressure gage agrees with warning signal, check as in subparagraph l, above. If gage does not agree with warning signal, check sending unit and panel unit of low oil pressure warning indicator.

### n. Exhaust Stack Temperature Warning Signals Do Not Light When Ignition Switch Is Turned On.

Loose connections in circuit.	Tighten connections.
Bulb in panel unit burned out.	Replace bulb.
Sending unit inoperative.	Replace unit.

### o. Exhaust Stack Temperature Warning Signals Stay Lighted When Power Unit is "Warmed Up" And Operating.

Engine not operating.	Check engine at fault and correct.
Sending unit or circuit at fault.	Check and correct, as necessary.

**ORDNANCE MAINTENANCE – POWER UNIT FOR  
MEDIUM TANKS M3A4 AND M4A4**

**p. Power Unit Continues To Run After Ignition Switch Is Turned Off.**

Probable Cause

Probable Remedy

Preignition.

Open carburetor throttle wide and continue to hold open until power unit stops.

**q. Power Unit Idles Too Fast.**

Throttle rod and linkage binding. Free up.

Idling speed improperly adjusted. Adjust.

**r. Abnormal Vibration.**

Dirt accumulated in fan and clutch. Remove dirt.

Fan blades broken or damaged. Repair or replace.

**s. Steam Coming From Radiator, Water Temperature Not Over 212 F.**

Radiator pressure vent valve not operating properly. Replace valve.

**t. Loss Of Radiator Coolant.**

Leaks in water hose or tubes. Locate leaks, tighten connections or replace parts, as necessary.

Leaks in water pump seal. Repair or replace.

Leaks in radiator. Repair or replace.

**u. Tachometer Does Not Register.**

Drive cable broken. Repair or replace.

Drive cable "kinked." Correct installation.

Unit on instrument panel inoperative. Repair or replace.

## TROUBLE SHOOTING

## 13. TROUBLE SHOOTING (INDIVIDUAL ENGINE).

## a. Engine Turns But Will Not Start.

Probable Cause	Probable Remedy
Distributor rotor not turning.	Repair or replace distributor or drive gear.
Cracked distributor cap and/or rotor.	Replace cap and/or rotor.
Condenser shorted.	Replace.
Distributor needs new points or present points lack sufficient gap.	Adjust or replace.
Ignition coil wire (primary or high tension) broken or loose.	Tighten connections, repair or replace wire.
Defective insulation on coil wire (primary or high tension) causing short circuit.	Repair or replace wire.
Accumulation of moisture, dirt or oil on distributor cap, coil tower or spark plugs.	Clean and dry out.
Lack of fuel.	Check lines and carburetor for obstructions and remove.

**ORDNANCE MAINTENANCE – POWER UNIT FOR  
MEDIUM TANKS M3A4 AND M4A4**

**Section III**

**REMOVAL**

**Paragraph**

Removal of power unit..... **14**

**14. REMOVAL OF POWER UNIT.**

- a. Refer to TM 9-754, paragraph 52.

Section IV

**DISASSEMBLY OF POWER UNIT**

Paragraph

General .....	15
Disassemble power unit.....	16

**15. GENERAL.**

a. Due to the construction of the power unit, it is necessary to remove the drive gear housing assembly before attempting to remove either individual engine assembly from the crankcase. It is seldom that a complete disassembly will be necessary. Therefore, first determine how complete the disassembly must be, then determine what subassemblies will require complete disassembly. In this manner, considerable time can be saved both in disassembly and assembly. In the event that only No. 5 engine is to be removed, it will be necessary to remove No. 4 engine first, because of insufficient clearance between No. 4 manifold and No. 5 engine. In the event that only 1 of the other 4 engines is to be removed, this can be accomplished without removing the other engines.

b. To remove each engine assembly, the power unit (Nos. 1, 2, 3, 4, and 5 engines), has to be rolled over to remove the individual engine assemblies. *Due to the similarity of parts and to simplify reassembling, a method of segregating and tagging parts should be adopted. Benches or allotted spaces on floor or ground should be set apart to receive the parts and accessories removed from the individual engines. Place parts in space provided. This will render the identification of parts more feasible.*

**16. DISASSEMBLE POWER UNIT.**

**a. Equipment.**

- |                                       |                      |
|---------------------------------------|----------------------|
| BEAM, wood, 2- x 8-in. x 8-ft.<br>(2) | PLIERS, adjustable   |
| BLOCK, wood, 2- x 4-in.               | PLIERS, side cutting |
| BLOCK, wood, 4- x 4- x 4-in.          | PRESS, heavy duty    |
| CHISEL, flat                          | PULLER, universal    |
| DRIFT, brass                          | PUNCH, prick         |
| HAMMER, steel                         | SCREWDRIVER          |
| HOIST, 1-ton (2)                      | STAND, MTM A4-29     |
| JACK                                  | WRENCH, 1/4-in.      |
| PLATE, engine lifting, MTM            | WRENCH, 3/8-in.      |
| A4-36                                 | WRENCH, 7/8-in.      |
|                                       | WRENCH, 1/2-in.      |



**ORDNANCE MAINTENANCE – POWER UNIT FOR  
MEDIUM TANKS M3A4 AND M4A4**

WRENCH,  $\frac{3}{8}$ -in.  
 WRENCH,  $\frac{5}{8}$ -in.,  
 WRENCH,  $\frac{3}{4}$ -in.  
 WRENCH,  $1\frac{1}{8}$ -in.  
 WRENCH,  $\frac{7}{8}$ -in., and 3-ft.  
 extension  
 WRENCH, 1-in.  
 WRENCH, open-end,  $\frac{7}{16}$ -in.  
 WRENCH, open-end,  $\frac{1}{2}$ -in.  
 WRENCH, open-end,  $\frac{9}{16}$ -in.  
 WRENCH, open-end,  $\frac{5}{8}$ -in.  
 WRENCH, open-end,  $\frac{3}{4}$ -in.  
 WRENCH, open-end,  $\frac{7}{8}$ -in.

WRENCH, socket,  $\frac{3}{8}$ -in., and  
 3-in. extension  
 WRENCH, socket,  $\frac{1}{2}$ -in., and  
 3-in. extension  
 WRENCH, socket,  $\frac{9}{16}$ -in., and  
 extension  
 WRENCH, socket,  $\frac{7}{8}$ -in.  
 WRENCH, socket, deep,  $1\frac{1}{8}$ -in.  
 WRENCH, socket,  $1\frac{5}{8}$ -in.  
 WRENCH, socket,  $2\frac{1}{8}$ -in.  
 WRENCH, spanner, closed,  
 MTM A4-7  
 WRENCH, spanner, MTM  
 A4-2

**b. Procedure.**

(1) WITH UNIT MOUNTED ON STAND MTM A4-29, REMOVE CLUTCH AND FAN ASSEMBLY. Refer to TM 9-754, paragraph 93 b.

(2) REMOVE RADIATOR ASSEMBLY. Refer to TM 9-754, paragraph 90 b.

(3) REMOVE CHOKE RODS.

PLIERS, side cutting

Remove the choke rods from choke cross shaft to Nos. 2, 1 and 5 carburetors by removing cotter pins and clevis pins. Likewise, remove choke rods between No. 2 and No. 3 carburetors, and No. 5 and No. 4 carburetors. Tag rods for identification.

(4) REMOVE CHOKE CROSS SHAFT.

WRENCH,  $\frac{5}{8}$ -in.

Remove 4 cap screws securing choke cross shaft brackets to No. 2 cylinder block and No. 5 cylinder block, and remove the cross shaft (fig. 193). The spacers under the brackets are to hold brackets away from casting web. Tag for identification.

(5) REMOVE CARBURETOR ACCELERATOR RODS.

PLIERS, side cutting

WRENCH, open-end,  $\frac{1}{2}$ -in.

Remove cotter pins (side cutting pliers) and disconnect throttle rods from carburetor throttle shaft levers (unscrew ball joint screw of vertical throttle rod from throttle shaft lever, No. 2 carburetor only ( $\frac{1}{2}$ -in. open-end wrench) ) (fig. 8). Tag rods for identification.

## DISASSEMBLY OF POWER UNIT

## (6) REMOVE THROTTLE ROD BELL CRANK AND BRACKET.

PLIERS, side cutting

WRENCH,  $\frac{1}{2}$ -in.

Remove throttle spring attached to bell crank and No. 2 carburetor. Remove cotter pin (side cutting pliers) and remove flat washer and bell crank from bell crank bracket. Push main throttle rod toward No. 2 carburetor, compressing spring, and exposing cotter pin, remove cotter pin and flat washer and separate rod from bell crank. Remove 2 cap screws ( $\frac{1}{2}$ -in. wrench) holding bracket to No. 2 engine intake manifold (fig. 8) and tag for identification.

## (7) REMOVE CARBURETOR TO AIR CLEANER TUBE.

PLIERS, side cutting

Remove lock wire and loosen thumbscrews which secure hose clamps sufficiently to permit disconnecting the air cleaner tubes from the carburetors (fig. 5). Remove tube assemblies from carburetor.

## (8) REMOVE CARBURETOR AND GOVERNOR ASSEMBLY.

PLIERS, side cutting

WRENCH, open-end,  $\frac{9}{16}$ -in.

Unscrew the flexible fuel tube *at the end connecting to the fuel distributor block first* to permit unscrewing the line with its integral connector at the carburetor fuel filter (turn counterclockwise) ( $\frac{9}{16}$ -in. open-end wrench). Remove lock wire (side cutting pliers) and remove 2 nuts ( $\frac{9}{16}$ -in. open-end wrench) securing carburetor and governor assembly to intake manifold elbow (No. 1 carburetor is mounted directly to the intake manifold). Lift carburetor and governor assembly off manifold or elbow. Remove elbows on Nos. 2, 3, 4 and 5 intake manifolds by removing 4 nuts and pal nuts ( $\frac{9}{16}$ -in. wrench). NOTE: When removing No. 2 manifold elbow, remove bracket assembly held by 1 nut and pal nut ( $\frac{9}{16}$ -in. wrench) to the elbow, which secures fuel line between Nos. 2 and 3 carburetors. Also remove brace from under No. 4 carburetor elbow to No. 4 engine by removing lock wire (side cutting pliers) and 2 nuts and lock washers ( $\frac{9}{16}$ -in. open-end wrench). Cover openings in manifolds to exclude any dirt from interior of engines. Tag carburetors and elbows for identification.

## (9) REMOVE AIR RELIEF TUBE.

WRENCH,  $\frac{5}{8}$ -in.

Remove tubing connecting the multiple water pumps by unscrewing tubes from connectors (not applicable to single water pump).

## (10) REMOVE RADIATOR INLETS (Up To And Including M4A4-3211) (fig. 5).

PLIERS, side cutting

Remove locking wire from hose clamp thumbscrews and loosen screws.

**ORDNANCE MAINTENANCE — POWER UNIT FOR  
MEDIUM TANKS M3A4 AND M4A4**

Slide hose clamp until it clears end of hose and remove inlets (left, center and right radiator inlets, already released from radiator during the removal of radiator).

(11) REMOVE RADIATOR INLET ELBOW AND BODY ASSEMBLY (After M4A4-3211).

**PLIERS**, side cutting

**WRENCH**, ½-in.

Remove locking wire from hose clamp thumbscrews and loosen screws and remove hose connected to engine outlet tube assemblies (left and right). Also disconnect the bypass center tube connecting the left and right inlet elbows and the No. 1 cylinder head adapter. Remove the hose connected to the No. 1 cylinder head adapter that connects to the radiator center inlet. **NOTE:** The bypass thermostats for Nos. 2 and 3, and 4 and 5 engines are mounted in the radiator inlet and inlet elbow assemblies. No. 1 is mounted in No. 1 cylinder head adapter. Remove 8 cap screws and lock washers (½-in. wrench) and separate inlet elbow and body and remove thermostats.

(12) REMOVE ENGINE WATER OUTLET TUBES AND ELBOWS (fig. 193).

**PLIERS**, side cutting

**WRENCH**,  $\frac{9}{16}$ -in.

Remove locking wire (side cutting pliers) from hose clamp thumbscrews. Slide hose clamp until it clears end of hose and remove hose from outlet tubes (Nos. 2 and 3 engines, and Nos. 4 and 5 engines, and outlet elbow (No. 1 engine) ). With  $\frac{9}{16}$ -in. wrench, remove 2 cap screws holding each outlet tube or elbow to cylinder head adapter and remove tube or elbow.

(13) REMOVE CRANKCASE VENTILATOR AIR CLEANER OUTLET PIPE.

**PLIERS**, side cutting

**WRENCH**, ½-in.

Remove the wire holding air cleaner pipe (with hose attached) in vertical position, and remove bolt which attaches elbow to left side of No. 5 engine, at radiator end (½-in. wrench). Lift elbow and tube out of opening in cylinder block.

(14) REMOVE RADIATOR OUTLET TUBE ASSEMBLY.

**PLIERS**, side cutting

Remove the bypass tube (fig. 197) (on power units after M4A4-3211) from the left radiator outlet tube by removing locking wire (side cutting pliers) and loosening thumbscrews and sliding hose away from outlet tube. Disconnect the radiator outlet tubes (left and right) from the water pump (single) (fig. 3) or water pumps (multiple) by disconnecting hose (fig. 2). Remove outlet tube assemblies.

**DISASSEMBLY OF POWER UNIT**

**(15) REMOVE STEP FROM NO. 1 ENGINE.**

**WRENCH,  $\frac{5}{8}$ -in.**

Remove 4 nuts and pal nuts which secure step to cylinder head of No. 1 engine and remove step.

**(16) REMOVE EXHAUST PIPE ASSEMBLY.**

**WRENCH,  $\frac{9}{16}$ -in.**

Remove 2 nuts and pal nuts from exhaust manifold flange (Nos. 1, 2, and 3 engines) (Nos. 4 and 5 engines) and remove exhaust pipe assemblies.

**(17) REMOVE HEAT SHIELDS.**

**WRENCH,  $\frac{5}{8}$ -in.**

Remove the 4 nuts and pal nuts securing heat shields to Nos. 2, 3, and 5 engines and remove shields.

**(18) REMOVE WATER PUMP OUTLET TUBES (Single Water Pump Type Only).**

**PLIERS, side cutting**

**WRENCH, socket,  $\frac{9}{16}$ -in.**

Remove locking wire (side cutting pliers) and remove 2 cap screws (at water pump end) ( $\frac{9}{16}$ -in. socket wrench). Remove 2 cap screws (at cylinder block end) ( $\frac{9}{16}$ -in. socket wrench) and remove the 5 water pump outlet tubes (fig. 3).

**(19) REMOVE IGNITION WIRING HARNESS AND BRACKET ASSEMBLY.**

**PLIERS, side cutting**

**WRENCH,  $\frac{3}{8}$ -in.**

**SCREWDRIVER**

**WRENCH,  $\frac{5}{8}$ -in.**

Remove wires from coils by unscrewing knurled nut in center of coil which encircles wire and separate high tension wire from coil. Remove nut and lock washer which secures the black wire (which enters metal conduit near coil) to terminal and lift wire off terminal ( $\frac{3}{8}$ -in. wrench). **NOTE:** Do not disconnect other black wire on this end of coil on which nut is soldered to terminal. Remove locking wires, remove 2 screws and remove distributor cap (part of harness assembly) from distributor (side cutting pliers and screwdriver). Remove cylinder head stud nuts ( $\frac{5}{8}$ -in. wrench) securing bracket to cylinder head and remove harness assembly from engine (fig. 11). Repeat operation to remove assemblies from all engines. Tag assemblies for identification.

**(20) REMOVE COILS.**

**PLIERS, side cutting**

**WRENCH,  $\frac{9}{16}$ -in.**

**WRENCH,  $\frac{3}{8}$ -in.**

Remove nut ( $\frac{3}{8}$ -in. wrench) and lift the 2 wires (white with green tracer) from end of coil. Remove locking wire (side cutting pliers) and

**ORDNANCE MAINTENANCE – POWER UNIT FOR  
MEDIUM TANKS M3A4 AND M4A4**

remove 2 nuts and lock washers securing coil to bracket and remove the 5 individual coils (fig. 1). Tag coils, wires, and conduits for identification.

**(21) REMOVE SENDING UNIT HARNESS.**

**SCREWDRIVER**

**WRENCH,  $\frac{9}{16}$ -in.**

**PLIERS, adjustable**

**WRENCH,  $\frac{5}{8}$ -in.**

Tag connections to all sending units and location of clips on the harness to enable correct installation. Remove wire from center of sending units (located in the top of No. 1 cylinder head adapter on single water pump type and in all adapters on multiple water pump type; in right side of cylinder head, at radiator end, on all engines; under side of No. 4 engine on multiple water pump type; on upper side of No. 3 engine and right side of No. 1 engine, at radiator end, on single water pump type; and at left side of crankcase, at bottom, on all models), by removing 2 screws (screwdriver) which attaches shield to unit, separating shield and then applying pliers to metal terminal end of wire. Pull wire from unit (adjustable pliers). **NOTE:** This is applicable to all the sending units (located on exhaust manifold of each engine) which require removing lock wire and 1 screw (side cutting pliers and screwdriver) to separate wire from unit. Remove nuts and pal nuts ( $\frac{9}{16}$ - and  $\frac{5}{8}$ -in. wrenches) which hold clips to engines at various locations, securing harness encircling the individual engines (radiator end). Remove 2 nuts ( $\frac{5}{8}$ -in. wrench) which holds bracket to top of No. 2 engine cylinder head and remove harness assembly.

**(22) REMOVE GENERATOR (Multiple Water Pump Type Only).**

**PLIERS, side cutting**

**WRENCH, open-end,  $\frac{5}{8}$ -in.**

**SCREWDRIVER**

**WRENCH, spanner, closed,**

**WRENCH, open-end,  $\frac{1}{2}$ -in.**

**MTM A4-7**

On power units equipped with the multiple water pumps, the generator is mounted to No. 2 engine. Loosen adjusting flange set screw on No. 2 water pump (screwdriver) by first loosening lock nut ( $\frac{1}{2}$ -in. open-end wrench). Unscrew flange from hub (turn clockwise) using closed spanner wrench, MTM A4-7. Remove belt from pulley. Remove locking wire (side cutting pliers) and remove screw (screwdriver) which secures fuel line to top of generator. Remove 2 pal nuts and 2 generator mounting nuts from No. 2 engine cylinder head stud nuts ( $\frac{5}{8}$ -in. open-end wrench). Remove 2 cap screws at lower end of generator bracket and lift generator off engine (fig. 1).

**(23) REMOVE IGNITION FILTER (M3A4 ONLY).**

**WRENCH,  $\frac{9}{16}$ -in.**

**WRENCH,  $\frac{5}{8}$ -in.**

Remove 1 cylinder head stud nut and pal nut which attaches upper end

**DISASSEMBLY OF POWER UNIT**

of bracket to No. 2 cylinder head ( $\frac{5}{8}$ -in. wrench). Remove 2 capscrews which attach lower end of bracket to No. 1 engine ( $\frac{9}{16}$ -in. wrench) and lift assembly from engine.

**(24) REMOVE STARTER (fig. 193).**

**PLIERS**, side cutting

**WRENCH**,  $\frac{7}{8}$ -in.

Remove locking wire (side cutting pliers) and remove 4 mounting bolts ( $\frac{7}{8}$ -in. wrench). **NOTE:** It will be necessary to raise starter  $\frac{1}{4}$ -inch to clear dowel pins in bracket.

**(25) REMOVE ABSORPTION TYPE OIL FILTERS AND BRACKET.**

**WRENCH**,  $\frac{9}{16}$ -in.

**WRENCH**, open-end,  $\frac{7}{16}$ -in.

**WRENCH**,  $\frac{5}{8}$ -in.

Unscrew inlet tube at connection on right side of No. 1 cylinder block ( $\frac{7}{16}$ -in. open-end wrench) and the connection on end of tube in the gear case ( $\frac{7}{16}$ -in. open-end wrench). Remove 2 nuts ( $\frac{9}{16}$ -in. wrench) which hold clips supporting the tubes. Remove 4 nuts and pal nuts ( $\frac{5}{8}$ -in. wrench) which mount bracket to No. 1 engine and remove oil filters and bracket.

**(26) REMOVE CRANKCASE BREATHER TUBE.**

**WRENCH**,  $\frac{1}{2}$ -in.

Remove bolt which attaches elbow to left side of No. 1 engine, at radiator end, withdraw elbow from engine and remove assembly.

**(27) REMOVE FUEL TUBES AND DISTRIBUTION BLOCKS.**

**WRENCH**, open-end,  $\frac{1}{2}$ -in.

**WRENCH**, open-end,  $\frac{3}{4}$ -in.

**WRENCH**, open-end,  $\frac{5}{8}$ -in.

Unscrew the 3 outlet tubes from the fuel pump connector (applicable to the multiple water pump type) ( $\frac{5}{8}$ -in. open-end wrench) (fig. 194) or the 1 outlet tube (applicable to the single water pump type ( $\frac{3}{4}$ -in. open-end wrench) (fig. 123) (turn counterclockwise). Unscrew these outlet tubes (or tube) from distribution block and all tubes leading to other distribution blocks and remove tubes ( $\frac{1}{2}$ -in. and  $\frac{5}{8}$ -in. open-end wrenches).

**(28) REMOVE FUEL PUMP (Multiple Water Pump Type).**

**PLIERS**, side cutting

**WRENCH**, open-end,  $\frac{1}{2}$ -in.

Remove locking wires and remove the 4 cap screws which secure pump to adapter. Remove pump from adapter. Remove locking wires and remove the 8 cap screws which secure adapter to crankcase. Withdraw adapter and shaft from crankcase.

**ORDNANCE MAINTENANCE – POWER UNIT FOR  
MEDIUM TANKS M3A4 AND M4A4**

**(29) TRANSFER ASSEMBLY FROM STAND TO FLOOR.**

- |                                |                            |
|--------------------------------|----------------------------|
| BEAM, wood, 2- x 8-in. x 8-ft. | PLATE, engine lifting, MTM |
| (2)                            | A4-36                      |
| HOIST (2)                      | SLING, MTM A4-18           |

Using a sling MTM A4-18 and 2 plates MTM A4-36, lift engines and crankcase assembly off 3 engine supports and lower onto two 2- x 8-in. wood beams. Support engine with blocks under Nos. 3 and 4 engines to keep from rolling. No. 1 engine should be straight up.

**(30) REMOVE DRIVE GEAR HOUSING MOUNTING BOLTS.**

- |                                      |                                    |
|--------------------------------------|------------------------------------|
| WRENCH, socket, $\frac{9}{16}$ -in.  | WRENCH, socket, $\frac{7}{8}$ -in. |
| WRENCH, socket, $\frac{5}{8}$ -in.   | WRENCH, extension, with uni-       |
| WRENCH, socket, $\frac{11}{16}$ -in. | versal joint, 3 feet long          |

Using 2 chains through the eyes in engine supports, bring the chain up to the top of gear case and take the weight of gear case in a hoist, so that case bolts can be removed. Remove 2 cap screws ( $\frac{11}{16}$ -in. wrench and  $\frac{7}{8}$ -in. wrench) from each side of engine. These cap screws are on the engine side of gear housing at the lower flange of the engine. A total of 20 cap screws have to be removed. The cap screws on the upper side of No. 4 engine have to be removed with a 3-foot extension and universal socket (fig. 145). NOTE: The engine-to-crankcase (at radiator end) cap screw of No. 4 engine has to be removed to get the horizontal cap screw out. From the radiator side of gear housing, remove 8 nuts ( $\frac{7}{8}$ -in. wrench) from housing attaching studs and 15 cap screws ( $\frac{5}{8}$ - and  $\frac{9}{16}$ -in. wrenches).

**(31) REMOVE DRIVE GEAR HOUSING FROM POWER UNIT.**

**HOIST**

With the weight of gear housing taken by a hoist, slide the gear housing away from the power unit (fig. 190). Remove engines from crankcase in the following order: Nos. 1, 2, 3, 4 and 5. In this manner the intake and exhaust manifold will not interfere as the complete power unit is being rolled over. If for any reason the No. 5 engine is the only one to be removed, No. 4 engine will have to be removed first, as the intake and exhaust manifold of No. 4 engine will interfere with the removal of No. 5 engine.

**(32) REMOVE SPARK PLUGS.**

- WRENCH, socket, deep,  $\frac{11}{16}$ -in.

Unscrew spark plug from cylinder head (turn counterclockwise). Cover openings with tape.

**DISASSEMBLY OF POWER UNIT****(33) REMOVE SENDING UNITS.****WRENCH,  $\frac{3}{8}$ -in.****WRENCH, 1-in.****WRENCH,  $\frac{7}{8}$ -in.****WRENCH, open-end,  $\frac{7}{16}$ -in.**

Remove 2 attaching nuts and lift exhaust stack temperature warning indicator sending units off the mounting studs ( $\frac{3}{8}$ -in. wrench) in the exhaust manifolds (fig. 10). Remove high water temperature warning indicator sending units from top of the cylinder head of each engine (multiple water pump type) or from the cylinder head of No. 1 engine only (single water pump type) (turn counterclockwise) (1-in. wrench). Remove the water temperature gage sending units from the side of the cylinder heads with a  $\frac{7}{16}$ -in. open-end wrench (turn counterclockwise). Remove the low oil pressure warning indicator sending unit from the underside of No. 4 engine (multiple water pump type) or from the right side of No. 1 engine, toward the radiator (single water pump type) ( $\frac{7}{8}$ -in. wrench) (turn counterclockwise). Remove the oil pressure gage sending unit from underside of No. 4 engine (multiple water pump type) (fig. 11) or from upper side of No. 3 engine (single water pump type) (fig. 9) (turn counterclockwise) ( $\frac{7}{16}$ -in. open-end wrench). Tag all units for easy identification.

**(34) REMOVE CYLINDER HEAD ADAPTERS AND THERMOSTATS.**

Remove 8 nuts, lift adapter off cylinder head and lift thermostats out of adapters. **NOTE:** Power units up to and including serial No. M4A4-3211 are equipped with thermostats inside engine water outlet adapters. After serial No. M4A4-3211, No. 1 engine thermostat is contained inside adapter, while other thermostats are contained in radiator inlet adapters.

**(35) REMOVE No. 1 ENGINE (fig. 150).****HOIST****WRENCH,  $\frac{7}{8}$ -in.****SLING, engine lifting**

Remove 16 cap screws which attach engine to crankcase. With lifting sling, attached to No. 1 engine cylinder head studs, lift out No. 1 engine. **CAUTION:** Pick engine up straight so that it will not bind on dowel pins.

**(36) REMOVE No. 2 ENGINE (fig. 149).****BLOCK, wood, 2- x 4-in.****SLING, engine lifting (2)****HOIST (2)**

Attach a lifting sling to cylinder head studs of engines Nos. 3 and 5 and, using 2 hoists, one on each side of the power unit, roll the power unit over until No. 2 engine is straight up. Then lower onto blocks to keep engine from tipping. Follow No. 1 removal procedure to remove.



**ORDNANCE MAINTENANCE – POWER UNIT FOR  
MEDIUM TANKS M3A4 AND M4A4**

(37) REMOVE NO. 3 ENGINE (fig. 148).

Roll power unit over again by hoist until No. 3 engine is straight up. Follow No. 1 removal procedure to remove.

(38) REMOVE NO. 4 ENGINE (fig. 145).

Turn power unit completely over until No. 4 engine is straight up. Follow No. 1 removal procedure to remove.

(39) REMOVE NO. 5 ENGINE (fig. 141).

Roll power unit until No. 5 engine is straight up and follow No. 1 removal procedure to remove.

(40) REMOVE WATER PUMP (SINGLE) (fig. 3).

**WRENCH**, open-end, 1/2-in.

Reach back of water pump and remove the 7 nuts and lock washers which attach water pump to crankcase. Remove water pump assembly from mounting studs. **NOTE:** For removal of multiple water pumps, see paragraph 17 b (13).

(41) REMOVE OIL PAN AND SCREEN FROM CRANKCASE.

**PLIERS**, side cutting

**WRENCH**, socket, 9/16-in.

**SCREWDRIVER**

Remove locking wire (side cutting pliers) from 26 cap screws and remove screws (9/16-in. socket wrench). The screen assembly attached to oil pan is secured with 20 screws (screwdriver) and should be removed for cleaning.

(42) REMOVE OIL PUMPS, PRESSURE AND SCAVENGER (fig. 148).

**PLIERS**, side cutting

**WRENCH**, socket, 9/16-in.

Remove locking wires (side cutting pliers) and 6 cap screws (9/16-in. socket wrench) from each pump and remove pumps from splined shafts.

(43) REMOVE ACCESSORY DRIVE SHAFT AND SUPPORT AND DIS-  
ASSEMBLE (fig. 139).

**DRIFT**

**WISE**

**HAMMER**, steel

**WRENCH**, socket, 9/16-in.

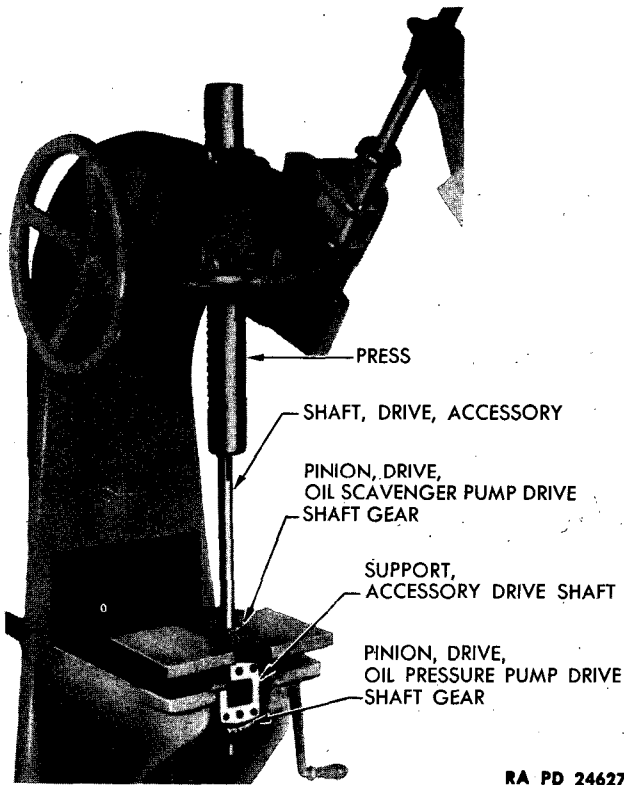
**PLIERS**, side cutting

**WRENCH**, spanner

**PRESS**

Reach through opening in crankcase and with side cutting pliers, remove locking wires and with 9/16-inch socket wrench, remove 4 cap screws which secure support to crankcase. Lift assembly off dowels and out of crankcase. Place assembly in vise, flatten ears of accessory shaft nut

## DISASSEMBLY OF POWER UNIT



RA PD 24627

**Figure 22 — Removing Accessory Shaft Gear**

lock washer to clear nuts on each side of gears and remove 2 drive shaft nuts with spanner wrench (turn counterclockwise). Place support and shaft on press and press the two gears off shaft (figs. 22 and 23). Mark the thrust washers, gears and shaft and mark the accessory shaft support for identification when reassembling in the event the same parts are to be used in reassembling. **NOTE:** The accessory shaft support bushings were line-reamed in assembly. The support must be kept with crankcase.

**(44) REMOVE OIL PUMP DRIVE SHAFTS AND GEARS.**

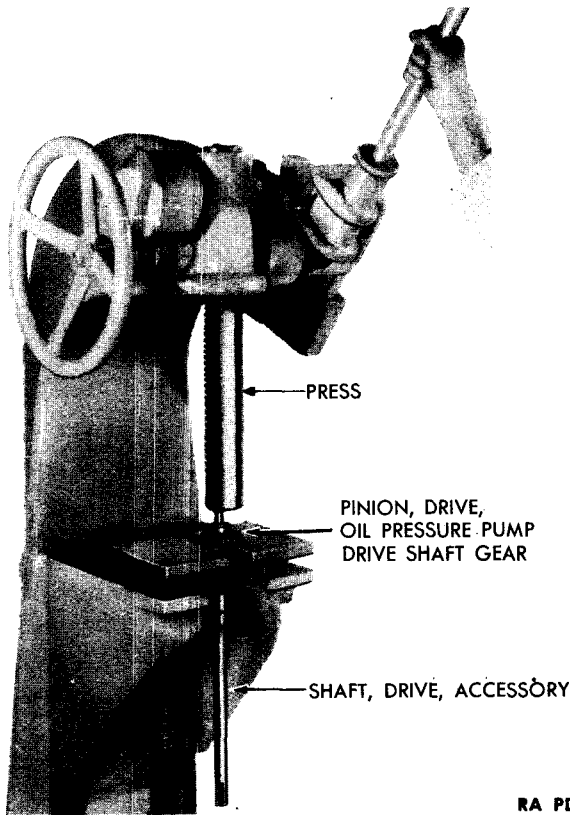
**HAMMER**

**WRENCH, socket,  $\frac{15}{8}$ -in.**

**PULLER, universal**

Bend back ears of washer (hammer) on each oil pump shaft and remove nut ( $\frac{15}{8}$ -in. socket wrench). Remove gears with universal puller. Slide oil pump shafts down through opening to underside of crankcase and remove.

ORDNANCE MAINTENANCE — POWER UNIT FOR  
MEDIUM TANKS M3A4 AND M4A4



RA PD 24629

**Figure 23 — Removing Accessory Shaft Gear**

(45) REMOVE SCAVENGER PUMP OUTLET ELBOW AND OIL FILTER PAD (fig. 146).

WRENCH,  $\frac{5}{8}$ -in.

Remove lock wires, 4 cap screws, and elbow and pad from crankcase.

(46) REMOVE ENGINE DRIVE GEARS (fig. 24).

BLOCK, wood, 4- x 4- x 4-in.

HAMMER, steel

CHISEL, flat

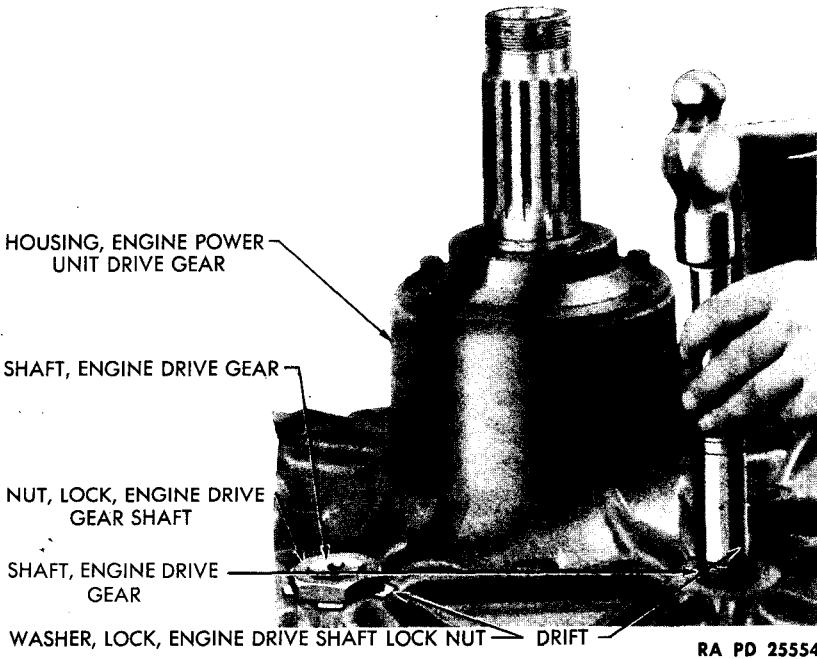
PUNCH, prick

DRIFT, brass

WRENCH, socket,  $2\frac{1}{8}$ -in.

Use hammer and flat chisel to straighten out the 5 engine drive gear shaft lock nut lock washers. Use a  $2\frac{1}{8}$ -inch socket wrench to remove the 5 lock nuts. Using prick punch and hammer, prick punch the end of each shaft and housing for identification in reassembly. NOTE: This is neces-

**DISASSEMBLY OF POWER UNIT**



**Figure 24 – Removing Engine Drive Gear Shaft**

sary as shafts are fitted into each opening in housing. Place a block, or some means of support, under the drive gear, to relieve any strain from gear and, using a brass drift and hammer, drive shaft out of housing and gear (fig. 24). Mark gears for identification to simplify assembly. When shaft has been removed, lift gear away from driven gear and remove from housing. Repeat operation to remove the 4 other gears.

**(47) REMOVE ENGINE DRIVE GEAR BEARINGS (fig. 167).**

**PRESS**

**SCREWDRIVER**

Insert end of screwdriver between lip at end of snap ring and hub of gear, forcing end of snap ring toward center of opening in hub. With snap ring in this position, force ring out of gear hub. Turn gear over and repeat operation to remove snap ring from the opposite side of hub. Place gear in press and press out the 2 engine drive gear bearings and spacer.

**(48) REMOVE ENGINE DRIVE GEAR CLUTCH.**

**WRENCH, socket,  $\frac{9}{16}$ -in.**

Remove the 8 bolts and nuts which secure clutch to gear. Lift clutch off gear (fig. 170).

**ORDNANCE MAINTENANCE — POWER UNIT FOR  
MEDIUM TANKS M3A4 AND M4A4**

**(49) REMOVE ENGINE DRIVEN GEAR AND SHAFT.**

**BLOCK**, wood, 4- x 4- x 4-in.

**CHISEL**, flat

**DRIFT**, brass

**HAMMER**, steel

**JACK**

**WRENCH**, socket,  $\frac{9}{16}$ -in.

**WRENCH**, socket,  $\frac{7}{8}$ -in.

**WRENCH**, spanner, MTM

**A4-2**

Using a  $\frac{7}{8}$ -inch socket wrench, remove the 2 cap screws which secure the engine drive gear housing seal plate to housing (fig. 176). When removing the seal plate, be careful not to damage the 2 rubber seals at each end of plate, as these seals are necessary to prevent oil leaks where the individual engines connect to gear housing. Remove plate from housing. Using a  $\frac{9}{16}$ -inch socket wrench, remove the 6 cap screws and lock washers which secure the engine driven gear shaft oil seal retainer to housing (fig. 189). Note the number and thickness of gaskets between retainer and housing as it is necessary to use the proper number of gaskets when reassembling, as these gaskets serve as shims between retainer and engine driven gear shaft outer bearing. Use hammer and chisel to bend the ends of the engine driven gear shaft outer bearing lock nut lock washer so as to permit turning of lock nut (fig. 184). Place suitable tool on end of engine driven gear shaft assembly to permit holding shaft in position, and using spanner wrench MTM A4-2, remove lock nut (turn counterclockwise) (fig. 183). Lay power unit drive gear housing assembly on blocks (with gear side of housing up). Place a jack under driven shaft (with a block of wood between jack and shaft, to protect end of shaft), raise jack and force shaft bearing and gear assembly out of housing. Using hammer and brass drift, tap engine driven gear shaft outer bearing out of housing. **CAUTION:** Protect bearing to prevent damage due to falling on floor.

**(50) REMOVE ENGINE DRIVEN GEAR FROM SHAFT (fig. 166).**

**CHISEL**, flat

**HAMMER**, steel

**PRESS**, heavy-duty

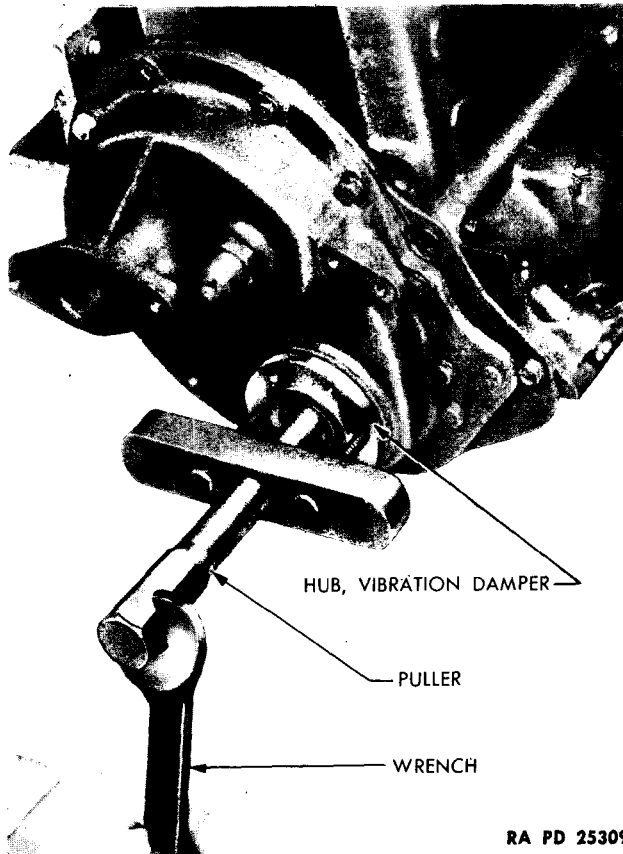
**WRENCH**, spanner

Using hammer and chisel, bend lock washer so as to permit turning of lock nut. Remove lock nut with spanner wrench (turn counterclockwise). Support shaft and gear assembly in a heavy-duty press, with long end of shaft down, and press gear off shaft. (Do not support this assembly on bearing, as it is necessary to remove the two keys which secure gear to shaft before the bearing can be removed.) Remove the two keys from shaft. Support shaft and bearing assembly in a heavy duty press (with long end of shaft down) and press bearing off shaft (turning the bearing as it is being removed).





**DISASSEMBLY OF INDIVIDUAL ENGINE**



**Figure 25 – Removing Vibration Damper Hub**

Remove 2 mounting nuts and lift distributor assembly off gear case cover ( $\frac{9}{16}$ -in. wrench). With stud remover, remove the 2 distributor mounting flange studs (fig. 114). Apply puller and remove vibration damper hub (fig. 25). Remove cap screws and stud nuts ( $\frac{1}{2}$ -in. wrench) which secure gear case cover to cylinder block and remove cover. Using  $1\frac{1}{8}$ -in. wrench, remove tachometer drive gear support nut and remove tachometer drive assembly. Using hammer and drift, drive pin out of tachometer drive gear and shaft, and separate gear, shaft, and support (No. 1 engine only).

**(7) REMOVE FUEL PUMP AND ADAPTER (No. 4 Engine Only).**

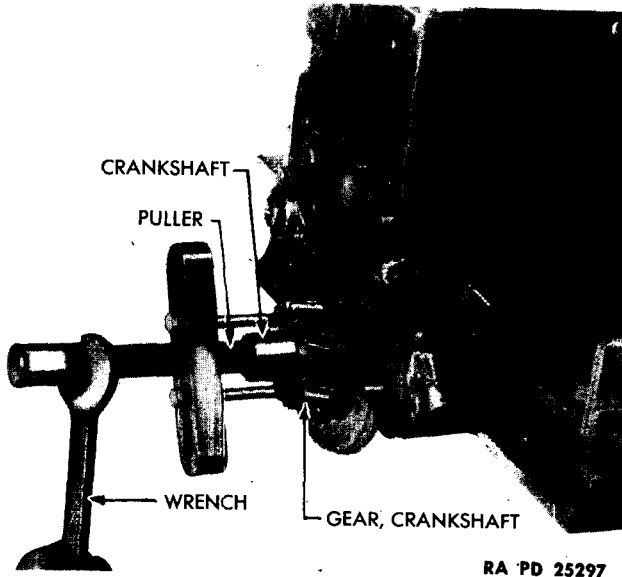
**PLIERS**, side cutting

**WRENCH**, socket,  $\frac{1}{2}$ -in.

Remove locking wires (side cutting pliers) and 4 cap screws and remove fuel pump from adapter. Remove lockwire (side cutting pliers) and



**ORDNANCE MAINTENANCE — POWER UNIT FOR  
MEDIUM TANKS M3A4 AND M4A4**



RA PD 25297

**Figure 26 — Removing Crankshaft Gear**

7 cap screws and withdraw adapter assembly from gear case cover.  
**NOTE:** On power units equipped with single water pump, the fuel pump is gear-driven off the camshaft, similar to that of the tachometer drive gear in engine No. 1.

**(8) REMOVE DISTRIBUTOR DRIVE GEAR AND CAMSHAFT GEAR.**

**CHISEL**

**WRENCH, socket, 3/4-in.**

**HAMMER**

With hammer and chisel, flatten ears of lock washer and remove 3 cap screws (3/4-in. socket wrench) and remove distributor drive gear. Lift camshaft gear off shaft (fig. 107).

**(9) REMOVE CAMSHAFT GEAR OIL TUBE.**

**WRENCH, socket, 7/8-in.**

Remove screw and clip to release oil tube and pull tube out from oilhole in cylinder block (fig. 105).

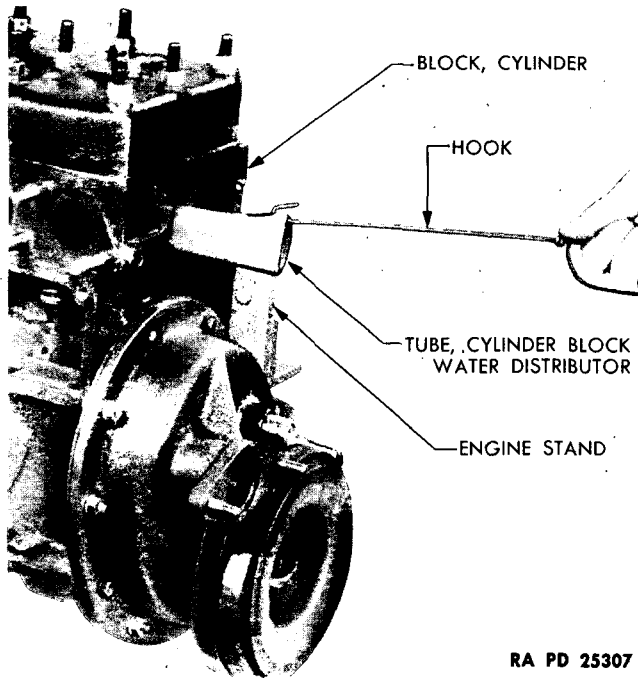
**(10) REMOVE GEAR CASE COVER PLATE AND GASKET.**

**SCREWDRIVER**

**WRENCH, socket, 1/2-in.**

Remove slotted head screw (screwdriver) and 4 cap screws (1/2-in. socket wrench) and remove plate and gasket (figs. 103 and 104).

## DISASSEMBLY OF INDIVIDUAL ENGINE



RA PD 25307

**Figure 27 — Removing Cylinder Block Water Distributor Tube**

- (11) REMOVE CRANKSHAFT GEAR.  
PULLER

Position puller and remove crankshaft gear (fig. 26).

- (12) REMOVE CRANKSHAFT OIL SEAL PLATE.  
SCREWDRIVER

Remove 2 screws and washers and remove oil seal plate (fig. 100).

- (13) REMOVE WATER PUMP (Multiple Water Pump Type Only).

PLIERS, side cutting

WRENCH, open-end,  $\frac{7}{8}$ -in.

SCREWDRIVER

WRENCH, open-end,  $\frac{1}{2}$ -in.

WRENCH,  $\frac{9}{16}$ -in.

WRENCH, spanner, MTM A4-7

Loosen lock nut on set screw, which secures belt adjusting flange ( $\frac{1}{2}$ -in. open-end wrench) and loosen set screw sufficiently to permit turning of flange (screwdriver) (fig. 122). Unscrew flange from pulley (turn clockwise) (spanner wrench MTM A4-7). Remove drive belt from pulley. Remove locking wire from hose clamp thumbscrews (side cutting pliers), loosen and move hose clamp toward water pump body, until it is clear of hose; then remove hose from pump. Remove 2 nuts and lock washers from mounting studs (No. 1 water pump only). **CAUTION:** Do not attempt to remove No. 1 water pump from engine until after the 4 cap

**ORDNANCE MAINTENANCE — POWER UNIT FOR  
MEDIUM TANKS M3A4 AND M4A4**

screws which secure water pump body to body cover plate are removed, inasmuch as plate remains on engine. Reach back of pump and remove these screws with  $\frac{7}{16}$ -inch open-end wrench. Remove 3 cap screws which secure pump on engines Nos. 2, 3, 4, and 5 and remove pump ( $\frac{3}{4}$ -in. open-end wrench). Remove slotted head screws and remove pump body plate from No. 1 engine (screwdriver).

(14) **REMOVE WATER PUMP OUTLET TUBE ADAPTER (Single Water Pump Type Only).**

**WRENCH,  $\frac{9}{16}$ -in.**

Remove 3 nuts and lock washers and remove water pump outlet tube adapter from distributor end of engine.

(15) **REMOVE CYLINDER BLOCK WATER DISTRIBUTOR TUBE.**

Insert hook into end of cylinder block and through opening near end of tube and pull tube from block (fig. 27).

(16) **REMOVE CONNECTING RODS AND PISTONS.**

**WRENCH,  $\frac{7}{8}$ -in.**

Turn over engine, mark connecting rods and caps for identification and location in engine, and remove 12 bearing cap bolt nuts ( $\frac{7}{8}$ -in. wrench) separating connecting rod caps and bearings (fig. 93). Push connecting rod and piston out through top of engine. As each connecting rod and piston assembly is removed from the engine, assemble the bearing inserts and cap in the same position in which they are removed (fig. 91).

(17) **REMOVE CRANKSHAFT AND BEARINGS.**

**WRENCH, socket, 1-in.**

Remove 4 bearing caps held by 2 cap screws each and lift crankshaft out of engine (fig. 71). Be sure bearing caps are marked for identification as these caps are not interchangeable. Lift bearings out of cylinder block.

(18) **REMOVE CAMSHAFT.**

**CHISEL**

**WRENCH,  $\frac{1}{2}$ -in.**

**HAMMER**

With hammer and chisel, straighten ears of locks and remove the 2 cap screws which secure camshaft thrust plate to cylinder block ( $\frac{1}{2}$ -in. wrench). Remove camshaft, rotating it as it is drawn out so that the cams will clear any objects. Remove hub of camshaft gear, snap ring, and thrust plate.

(19) **REMOVE TAPPETS.**

**BOARD, 12-hole**

With camshaft removed, reach into block and remove the 12 tappet assemblies. Place in board, drilled to receive each tappet and arranged in order and labeled for easy reassembling.

**Section VI**

**INSPECTION AND REPAIR OF PARTS**

	<b>Paragraph</b>
General .....	18
Inspection of components.....	19
Repair of components.....	20
Disassembly of components.....	21
Assembly of components.....	22

**18. GENERAL.**

a. Considerable time can be saved by making an inspection of the lubricating system before disassembly of the engine. This inspection may, through disclosing excessive clearances, more readily determine the necessity for replacement of parts. **NOTE:** Paragraph 31 lists minimum and maximum dimensions, as well as the limits allowed before replacing, and should be referred to when inspecting the components.

**19. INSPECTION OF COMPONENTS.**

**a. Lubricating System Inspection And Test.**

**TANK, No. 41-D-100**

Fill tank of tester  $\frac{1}{3}$  to  $\frac{1}{2}$  full of OIL, engine, SAE 10. Connect long hose to an air pressure supply. Remove oil distributor tube rear plug and attach short hose to this opening (fig. 29). Insert a plug in the locating dowel and oil inlet opening in bottom of cylinder block (at distributor end) (fig. 67). Turn on air pressure and adjust valve to secure a pressure of 50 to 55 pounds. Carefully study the oil leakage from each oil line connection, main bearings, connecting rod bearings, and camshaft bearings. A satisfactory bearing is indicated if leakage appears in well defined drops of 15 to 120 per minute. If leakage occurs in a steady stream, a serious condition is indicated. This also applies if the drops are of such size and shape that there is no time element noticeable between the drops.

**b. Cylinder Block.**

- AIR, compressed
- FILE, fine
- SCREWDRIVER
- STRAIGHTEDGE

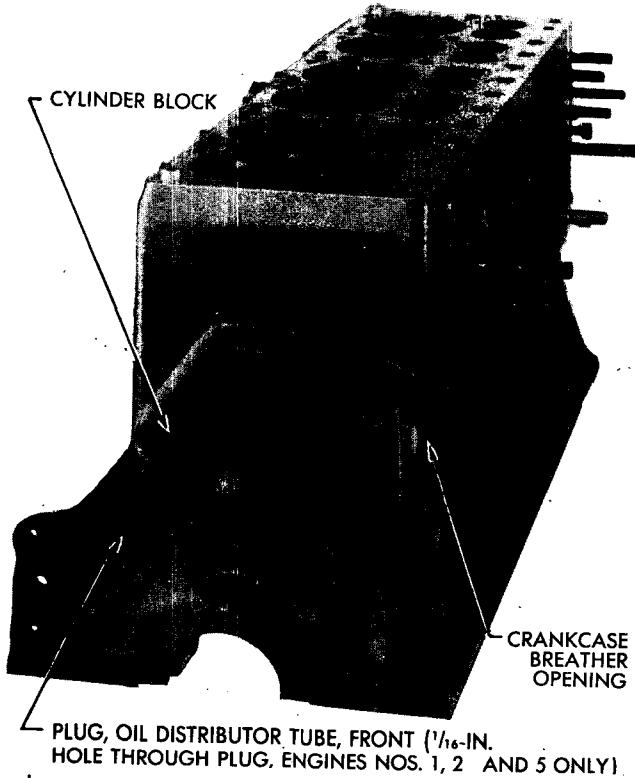
- TANK, for cleaning parts
- WRENCH,  $\frac{1}{2}$ -in.
- WRENCH, drain plug,  $\frac{1}{2}$ -in.
- WRENCH, open-end,  $\frac{1}{2}$ -in.

**(1) CLEAN CYLINDER BLOCK.**

- SCREWDRIVER
- TANK, for cleaning parts
- WRENCH,  $\frac{1}{2}$ -in.

- WRENCH, drain plug,  $\frac{1}{2}$ -in.
- WRENCH, open-end,  $\frac{1}{2}$ -in.

ORDNANCE MAINTENANCE — POWER UNIT FOR  
MEDIUM TANKS M3A4 AND M4A4



RA PD 25569

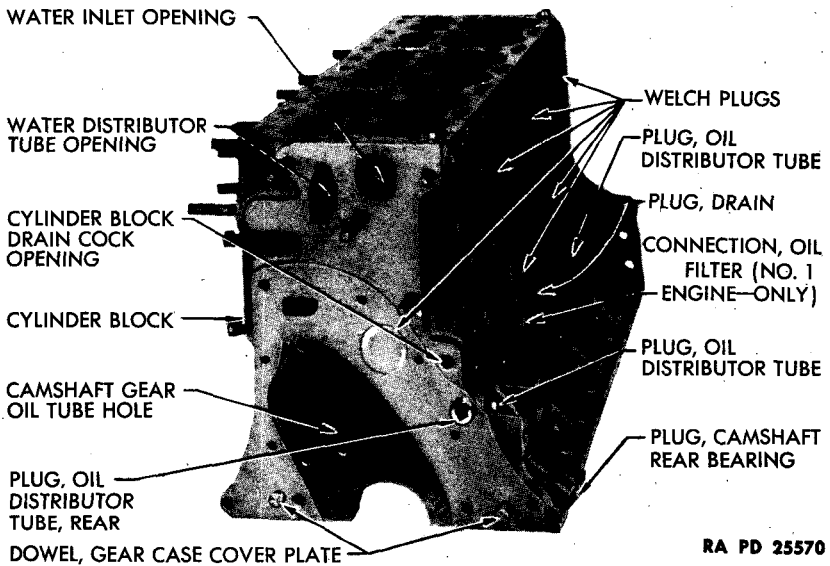
**Figure 28 — Engine Cylinder Block, Radiator End**

(a) Wash cylinder block thoroughly in SOLVENT, dry-cleaning, to remove all dirt and foreign matter. Wipe cylinder block dry.

(b) Remove oil distributor tube plugs, front and rear (figs. 28 and 29) (turn counterclockwise) ( $\frac{1}{2}$ -in. drain plug wrench). Remove 4 oil distributor plugs from right side of cylinder block (fig. 29) ( $\frac{1}{2}$ -in. wrench). Remove drain plug from right side of cylinder block ( $\frac{1}{2}$ -in. open-end wrench) (fig. 29). Remove camshaft rear bearing plug (screwdriver). Blow out all oil passages with compressed air, to remove all sediment and other foreign matter. CAUTION: Do not remove welch plugs shown in figures 28 and 29 for cleaning of cylinder block. Remove only if plug leaks.

(c) Check oil passages from each camshaft bearing to oil distributor tube and from each main bearing to the tube leading from oil distributor tube to camshaft bearings. Check camshaft gear oil tube hole in end of cylinder block, to be sure that passage from this hole to camshaft bearing

**INSPECTION AND REPAIR OF PARTS.**



**Figure 29 – Engine Cylinder Block, Distributor End**

is free from obstructions (fig. 29). Check passage from locating dowel and oil inlet opening (fig. 67) to oil distributor tube, to be sure passage is free from obstructions.

(d) Remove all sediment from water jacket of block. Install oil distributor tube plugs, front and rear ( $\frac{1}{2}$ -in. drain plug wrench) (figs. 28 and 29). **CAUTION:** When installing these plugs, be sure that plugs in radiator end of engines Nos. 1, 2, and 5 have a hole in center of plug. These engines furnish oil to the engine drive gear housing, therefore, only a plug with hole through center must be used in these engines. Install camshaft rear bearing plug (screwdriver) (fig. 29). Install the 4 oil distributor tube plugs (on right side of cylinder block (fig. 29)  $\frac{1}{2}$ -in. wrench).

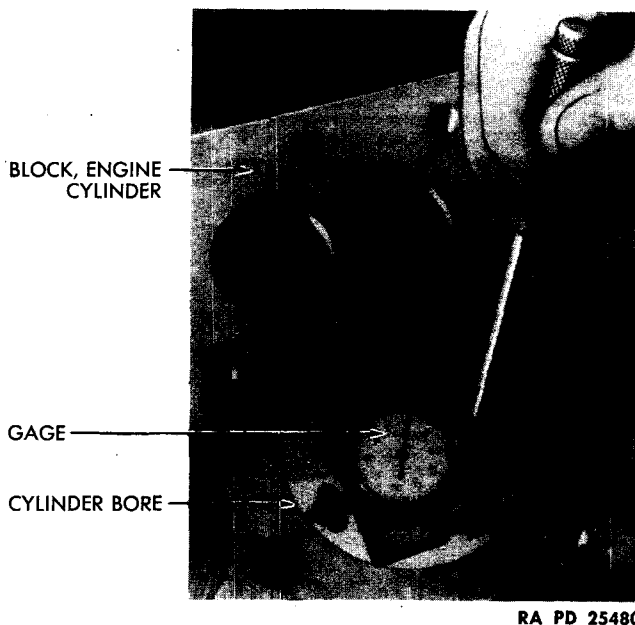
**(2) INSPECT BLOCK VISUALLY.**

**STRAIGHTEDGE**

(a) Inspect for evidence of water leaks around welch plugs.

(b) Inspect all casting surfaces for cracks or evidence of leakage. Inspect top face of cylinder block, paying particular attention to areas adjacent to valve seats and cylinder bores for evidence of leakage. Using a straightedge, inspect top face of cylinder block for low spots in the block and for high spots around stud holes. If the metal around the stud holes has been pulled to a point where light shows between straightedge and block, remove high spots with fine file. If either high or low spots in excess of 0.010-inch are noted, replace cylinder block.

**ORDNANCE MAINTENANCE — POWER UNIT FOR  
MEDIUM TANKS M3A4 AND M4A4**



RA PD 25480

**Figure 30 — Measuring Cylinder Bore Diameter**

(c) Inspect inside valve tappet chambers and inside valve ports for evidence of water leaks.

(d) Inspect lower face of cylinder block, distributor end, radiator end, and valve cover mounting faces to see that they are not warped, burred, nicked, or damaged in any way that will prevent a good gasket seal. Small burs can be removed with a fine file or whetstone.

(e) Inspect all screw holes in cylinder block to make sure that threads are in good condition. Be sure there are no cracks at these openings and that openings are free from dirt, to allow studs or cap screws to enter the full distance.

**(3) INSPECT CYLINDER BORES.**

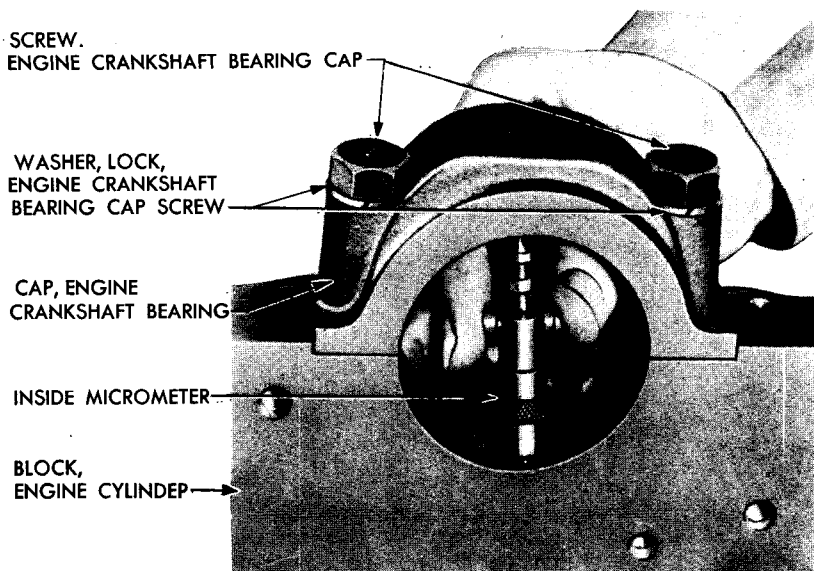
**GAGE**, cylinder, universal, Federal Stock No. 41-G-122

**MICROMETER**, outside, 3- to 4-in.

**LIGHT**, portable

(a) Hold light at bottom of cylinder bores and inspect for scores or rough surfaces in cylinder walls. If bores are scored, rebore and fit 0.020-inch oversize pistons. **NOTE:** Cylinder bore sizes are indicated by letters stamped on boss on right side of cylinder block, near top of block. Letter "A" 3.4375 inches; letter "B" 3.4380 inches; letter "C" 3.4385 inches; letter

**INSPECTION AND REPAIR OF PARTS**



RA PD 25449

**Figure 31 – Measuring Crankshaft Bearing Bore Diameter**

“D” 3.4390 inches; letter “E” 3.4395 inches. The maximum allowable out-of-round wear of the bore before reconditioning is 0.005 inch.

(b) To check cylinder bore sizes, adjust outside micrometer to proper size, place gage, Federal Stock No. 41-G-122, in micrometer and turn knurled ring until needle points to “ZERO.” Insert gage in cylinder bore and check diameter at various points in the bore (fig. 30). If inspection shows bore to be beyond the limits specified in (a) above, they should be rebored to 3.4575 inches and 0.020-inch oversize pistons installed.

**(4) CHECK CRANKSHAFT MAIN BEARING BORE DIAMETER (fig. 31).  
MICROMETER, inside**

Place cap in position on block and secure with 2 cap screws and lock washers. Using inside micrometer, measure diameter. The correct dimensions are 2.6565 to 2.6570 inches.

**c. Cylinder Head.**

- AIR, compressed
- BRUSH, power driven
- PAN, for cleaning

- PLATE, surface
- SCRAPER, carbon

**(1) CLEAN HEAD FOR INSPECTION.**

- AIR, compressed
- BRUSH, power driven
- PAN, for cleaning

- PLATE, surface
- SCRAPER, carbon



**ORDNANCE MAINTENANCE – POWER UNIT FOR  
MEDIUM TANKS M3A4 AND M4A4**

Using a scraper and power driven brush, remove all traces of carbon from combustion chambers of cylinder head. Wash cylinder head thoroughly in SOLVENT, dry-cleaning, to remove all dirt. Blow all moisture and dirt from head and wipe dry. Be sure to remove any loose particles from water jacket inside head.

**(2) INSPECT HEAD.**

GAGE, feeler

PLATE, surface

(a) Inspect mounting face of head and mounting face of adapter for any nicks or irregularities which may prevent a tight gasket seal.

(b) *Inspect Head Carefully For Any Evidence Of Leaks.*

(c) Lay cylinder head on a surface plate and inspect for warpage. With head resting on surface plate, use a feeler gage between head and plate to measure any warpage. If a 0.010-inch feeler gage can be inserted between head and plate at any point, replace cylinder head.

(d) Inspect threads in spark plug mounting holes, being sure that threads are in good condition.

(e) Inspect threads in adapter mounting stud holes, being sure that threads are in good condition and that openings are free from any foreign matter, which would not permit studs screwing into openings their full distance.

**d. Crankshaft And Crankshaft Gear.**

AIR, compressed

INDICATOR, dial and  
mounting

BAR, pinch

MICROMETER, outside, 2-3-in.

BLOCK, "V"

PLATE, surface

GAGE, feeler

WRENCH, socket, 3/4-in.

**(1) INSPECT VISUALLY.**

Inspect bearing journals for any nicks, scores, or wear. Light scratches on the journals can be corrected by polishing with CLOTH, crocus. Heavy scratches or scores will require grinding the journals down for use with undersized bearings. Inspect keyways and threads at end of shaft for nicks or damage. Inspect gear teeth for nicks and wear. CAUTION: Always handle crankshaft carefully, as dropping may "spring" it and render it useless for further service. Do not place shaft where objects will be dropped on it.

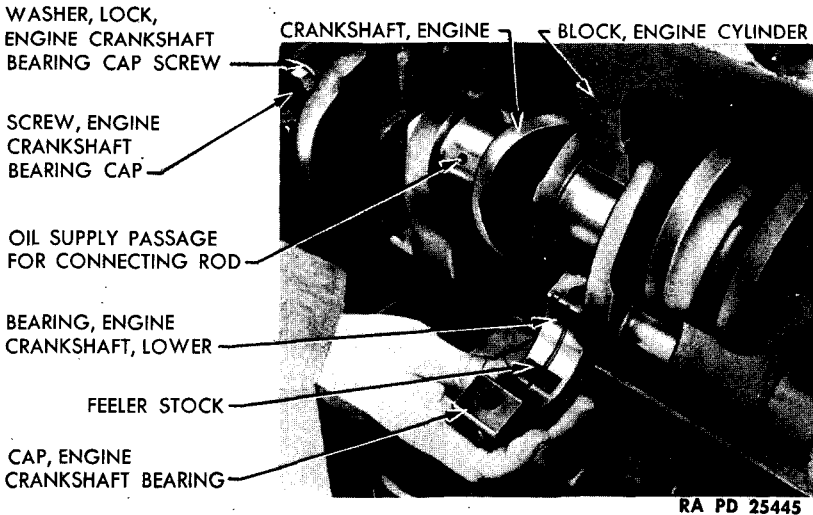
**(2) CHECK ALINEMENT.**

BLOCK, "V"

PLATE, surface

INDICATOR, dial and  
mounting

## INSPECTION AND REPAIR OF PARTS



**Figure 32 — Checking Crankshaft Bearing Clearance**

Place crankshaft on V-blocks, supporting shaft on No. 1 and No. 4 bearings. Using dial indicator, measure runout of bearing journals. Total runout should not exceed 0.002-inch.

**(3) CHECK BEARING CLEARANCES.**

BAR, pinch

WRENCH, socket,  $\frac{3}{4}$ -in.

GAGE, feeler

Position upper halves of crankshaft bearings in cylinder block, with lips on bearings fitted into recesses in block and bearings seating firmly in bottom of openings. Wipe shaft journals and lay shaft in bearings. Place bearing in cap, with lip on bearing fitted in recess in cap; place 0.002 inch thick brass shim ( $\frac{1}{2}$ -in. wide, 1-in. long) coated with oil, in bearing (fig. 32). Install cap on cylinder block and tighten with cap screws ( $\frac{3}{4}$ -in. socket wrench). If clearance is not excessive, a slight drag will be noted when crankshaft is rotated. If clearance is excessive, check bearing journals and, if out-of-round or scored, regrind shaft and install undersized bearings. Using feeler gage, check end play (fig. 76). Maximum allowable end play is 0.010 inch. If exceeded, replace No. 4 bearing.

**(4) CHECK JOURNAL DIAMETERS.**

MICROMETER, outside, 2- to 3-in.

Measure diameter of main and connecting rod journals with 2- to 3-inch outside micrometer. If diameter is less than 2.4970 inches for main bearing, or 2.1215 inches for connecting rod bearing journals, the journals should be reground and undersize bearings used.

**ORDNANCE MAINTENANCE – POWER UNIT FOR  
MEDIUM TANKS M3A4 AND M4A4**

**(5) CLEAN OIL PASSAGES.**

AIR, compressed

Using compressed air, blow out all drilled oil passages in crankshaft, blowing from main bearing journals to each connecting rod journal. Blow through these passages in both directions to assure thorough cleaning. After completing inspection, store shaft where it will not be damaged, while awaiting installation.

**e. Camshaft And Camshaft Gear.**

BLOCK, "V"

GAGE, plug, diameter, 1.250- to 1.251-in.

GAGE, plug, diameter, 1.9375- to 1.9385-in.

GAGE, plug, diameter, 1.969- to 1.970-in.

GAGE, plug, diameter, 2.000- to 2.001-in.

INDICATOR, dial and mounting

MICROMETER, outside, 1- to 2-in.

PLATE, surface

(1) Be sure to handle camshaft carefully and do not store it where it can become damaged.

(2) Inspect cams and bearing surfaces for any nicks, scores or wear and inspect gear teeth for wear.

**(3) MEASURE DIAMETER OF BEARING JOURNALS.**

MICROMETER, outside

Using micrometer, measure diameter of bearings. The correct dimensions are, No. 1, 1.998 to 1.999 inches; No. 2, 1.9665 to 1.9675 inches; No. 3, 1.935 to 1.936 inches; No. 4, 1.2475 to 1.2485 inches.

**(4) CHECK ALINEMENT.**

BLOCK, "V"

INDICATOR, dial and mounting

PLATE, surface

Place camshaft on V-blocks at No. 1 and No. 4 journal bearings over a surface plate. Mount dial indicator directly over center line of camshaft and touching it. Set dial indicator at "ZERO" on heel of each cam lobe and check base circle of each lobe in turn for 180 degrees. Set indicator on each bearing journal and check for the full 360 degrees. If runout of more than 0.0015-inch total indicator reading is discovered, either on the base of the cam lobes or bearing journals, the camshaft is sprung out of alinement and should be replaced. If camshaft is found to be within limits, store shaft where it will not be damaged, while awaiting installation in engine.

**INSPECTION AND REPAIR OF PARTS**

**(5) INSPECT BEARINGS IN CYLINDER BLOCK FOR WEAR.**

**GAGE**, plug, diameter, 1.250- to 1.251-in.

**GAGE**, plug, diameter, 1.969- to 1.970-in.

**GAGE**, plug, diameter, 1.9375- to 1.9385-in.

**GAGE**, plug, diameter, 2.000- to 2.001-in.

Using plug gages of respective sizes, check diameters of bearings. These dimensions should be No. 1, 2.000 to 2.001 inch; No. 2, 1.969 to 1.970 inch; No. 3, 1.9375 to 1.9385 inch; No. 4, 1.250 to 1.251 inch (reamed in gray iron cylinder block). Should inspection disclose that dimensions are excessive, the bearings should be removed and new bearings installed. **NOTE:** Bearings Nos. 1, 2, and 3 only are removable. These bearings are machined to size and require no scraping, reaming, or burnishing.

**f. Connecting Rod.**

**AIR**, compressed

**PRESS**, bench

**GAGE**, feeler

**SHIM**, 0.002-in., 1/2-in. wide,

**GAGE**, plug, diameter, 0.8595- to 0.8597-in.

3/4-in. long

**WISE**

**PAN**, cleaning

**(1) CLEAN CONNECTING ROD.**

**AIR**, compressed

**PAN**, cleaning

Wash thoroughly in **SOLVENT**, dry-cleaning, and dry for inspection. Apply compressed air to metered hole in lower end of rod to remove any foreign matter and to be sure hole is free from obstruction.

**(2) INSPECT ROD VISUALLY.**

Inspect rod carefully for any small cracks or evidence of damage.

**(3) INSPECT PISTON PIN BUSHING.**

**GAGE**, plug, diameter, 0.8595- to 0.8597-in.

**PRESS**, bench

Inspect bushing carefully to be sure it is tight in connecting rod. Using a plug gage, check bushing for size. The inside diameter should be 0.8595 to 0.8597 inch. If inside diameter of bushing is beyond these limits, press old bushing out of rod (fig. 33).

**(4) CHECK CONNECTING ROD LOWER BEARINGS (fig. 84).**

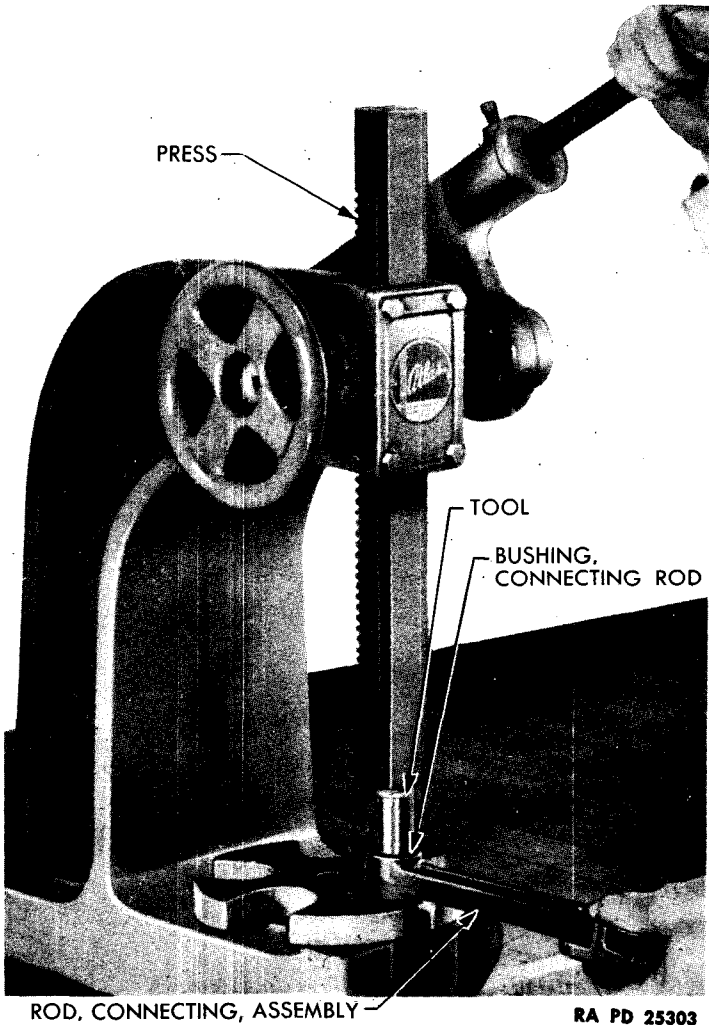
**GAGE**, feeler

**WRENCH**, socket, 1/4-in.

**SHIM**, 0.002-in. x 1/2-in. wide, 3/4-in. long

Fit lip of bearing into recess in rod and cap and be sure bearing is seated properly. Fit rod and bearing on respective connecting rod journal on

**ORDNANCE MAINTENANCE — POWER UNIT FOR  
MEDIUM TANKS M3A4 AND M4A4**



**Figure 33 — Removing Piston Pin Bushing**

crankshaft (in the same position as it was originally installed in engine) and check bearing wear. To check clearance between bearing and journal, coat a piece of 0.002-inch brass shim stock ( $\frac{1}{2}$ -in. wide and  $\frac{3}{4}$ -in. long) with oil and place it between the bearing and journal. Install cap and tighten nuts securely ( $\frac{1}{8}$ -in. socket wrench). If the clearance is not excessive, there will be a drag when the connecting rod is turned on shaft. The clearance should be 0.0005 to 0.002 inch. If clearance is excessive, and diameter of the crankshaft journals has not been checked, measure diameter of journal with micrometer, as outlined in paragraph 19 d (4).

## INSPECTION AND REPAIR OF PARTS

Remove cap, remove shim, and check end play of rod on crankshaft by installing cap on the rod, securing with bolts and nuts and inserting feeler gage between end of bearing and flange on crankshaft. This clearance should be 0.0055 to 0.0115 inch. If end play is excessive, replace with new connecting rod and bearing.

## g. Valves.

BRUSH, power driven  
BRUSH, wire

TESTER, valve spring, Federal  
Stock No. 17-T-1600  
MICROMETER, outside, 1-in.

## (1) CLEAN VALVES AND MAKE VISUAL INSPECTION.

BRUSH, power driven

MICROMETER, 1-in.

Clean valves thoroughly with a power driven brush, to remove all carbon and foreign matter from stem and head. Inspect head of valve for pit marks, burned spots or cracks on the seat. Inspect for a warped head. Measure stem of valve with 1-inch micrometer for excessive wear. This measurement should be: intake valve 0.3404 to 0.3415 inch, exhaust valve 0.3385 to 0.3395 inch. The maximum allowable stem wear, before replacing, is 0.002 inch.

## (2) INSPECT VALVE GUIDES.

BRUSH, wire

Inspect guide, to be sure it is tight in cylinder block and that it is not cracked or chipped at either end. Clean opening in guide with wire brush, removing all carbon. Place valves in respective guides and check clearance between stem and guide. This clearance should be: intake valve 0.001 to 0.003 inch; exhaust valve 0.003 to 0.005 inch. Maximum allowable clearance: intake 0.005 inch; exhaust 0.007 inch. If clearance is excessive, replace guide.

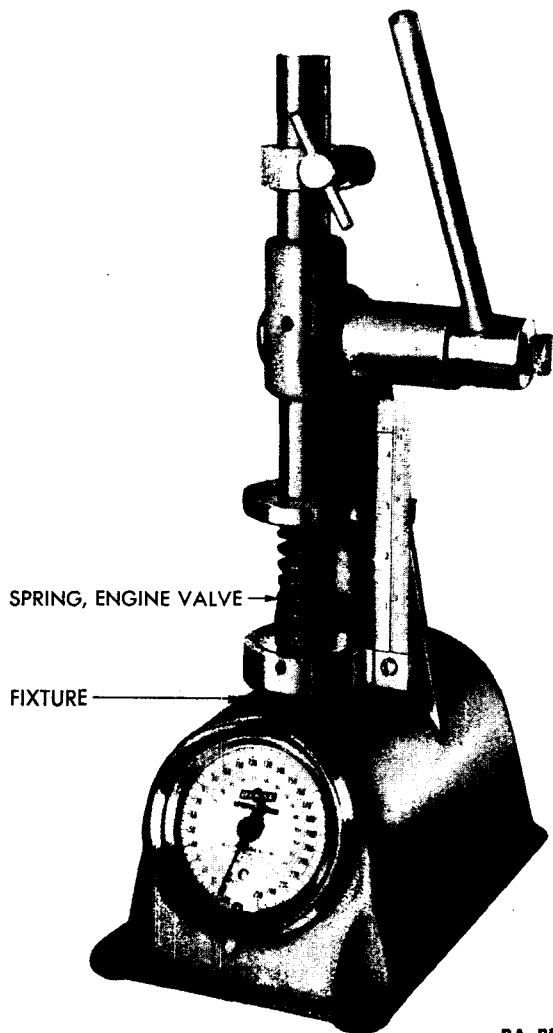
## (3) VALVE SEATS (In Cylinder Block).

(a) Because of the hardness of the valve seat insert, used in the exhaust valve ports, it is impossible to recut these seats with the ordinary cutter. *They must be reground with a stone.* The intake valve seats should be recut with a suitable valve seat cutter (45-degree angle) or the exhaust valve seat insert grinding tool may be used if care is exercised not to grind out more material than is necessary. The seats should be cut only enough to remove pits or other depressions in them. **NOTE:** *After grinding operations are completed it is important that every trace of grinding cuttings be removed from the valve seats and valve ports.*

## (b) Inspect Seat.

INDICATOR, dial

Make a thorough inspection of seat for cracks or depressions in seat or

ORDNANCE MAINTENANCE — POWER UNIT FOR  
MEDIUM TANKS M3A4 AND M4A4

**Figure 34 — Testing Valve Spring Pressure**

for clearance between seat and block. If seat is cracked or loose in block, replace with 0.010-inch oversize seat. Using dial indicator, check seat for runout. This runout must not exceed 0.0015-inch total indicator reading.

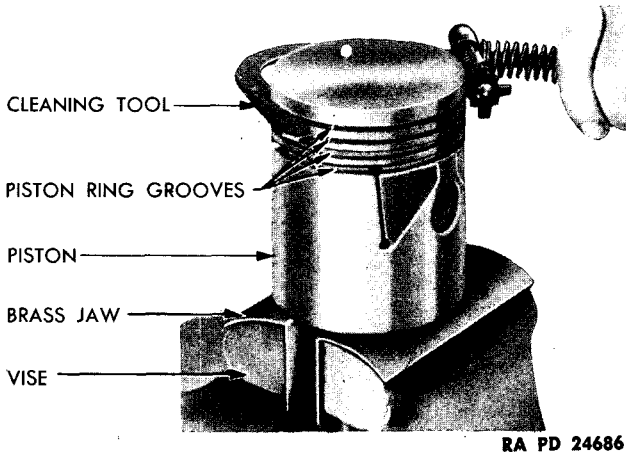
**(4) VALVE TAPPETS.**

*(a) Clean And Inspect Tappet.*

MICROMETER, outside, 1-in.

Clean tappet thoroughly, removing all foreign matter, to permit inspec-

**INSPECTION AND REPAIR OF PARTS**



**Figure 35 – Cleaning Ring Grooves**

tion. Measure outside diameter of tappet with micrometer. The correct measurement is 0.6235 to 0.6240 inch, clearance in guide 0.0000 to 0.001 inch (maximum allowable clearance 0.002-in.). Inspect tappets for cracks, scuffing, or flaws.

**(5) VALVE SPRINGS.**

**(a) Test Pressure (fig. 34).**

**TESTER**, valve spring, Federal Stock No. 17-T-1600

Place spring in fixture and test for proper pressure. When compressed to 1¾ inches the correct reading is 40 to 45 pounds. When compressed to 1⅜ inches the correct reading is 107 to 115 pounds. Replace the springs if these conditions are not satisfied.

**h. Pistons And Rings.**

**GAGE**, feeler

**GAGE**, plug, diameter, 0.8591- to 0.8594-in.

**MICROMETER**, outside, 1-in.

**MICROMETER**, outside, 3- to 4-in.

**PAN**, for cleaning

**SOLVENT**, dry-cleaning

**TOOL**, cleaning, ring groove

**TOOL**, piston ring installing

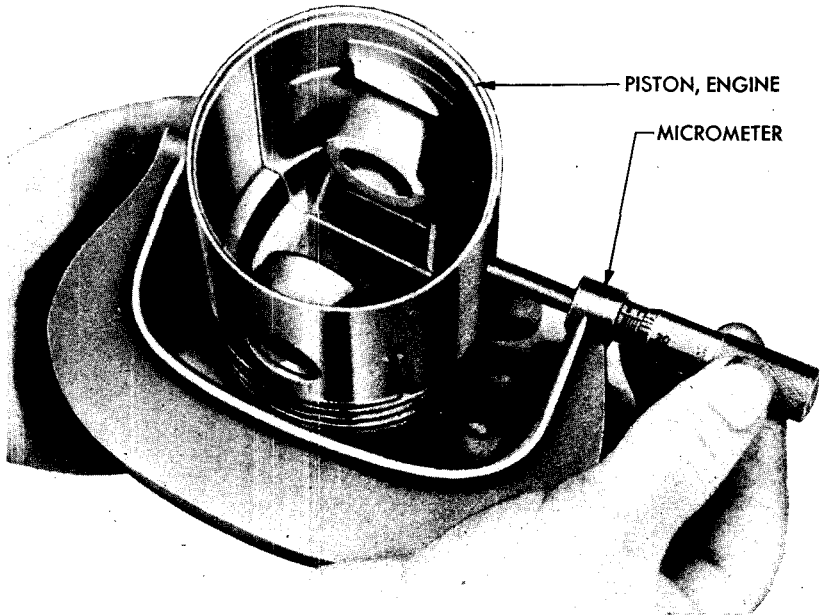
**(1) CLEAN PISTON AND INSPECT VISUALLY.**

**TOOL**, cleaning, ring groove

Using a ring groove cleaning tool, remove all carbon from ring grooves (fig. 35). Wash piston thoroughly in **SOLVENT**, dry-cleaning, removing all dirt and foreign matter from piston and oil return holes. Inspect piston carefully for scores and cracks. Inspect oil return holes, being sure all openings are free from obstructions.



**ORDNANCE MAINTENANCE – POWER UNIT FOR  
MEDIUM TANKS M3A4 AND M4A4**



RA PD 25437

**Figure 36 – Measuring Piston Diameter**

(2) CHECK DIAMETER OF PISTONS (fig. 36).

MICROMETER, outside, 3- to 4-in.

Measure diameter of piston with outside micrometer (fig. 37). The diameters should be as follows:

Letter Size	Piston Diam. "A"	Piston Diam. "B"
A	3.4352 to 3.4357-in.	3.4195 to 3.4215-in.
B	3.4357 to 3.4362-in.	3.4200 to 3.4220-in.
C	3.4362 to 3.4367-in.	3.4205 to 3.4225-in.
D	3.4367 to 3.4372-in.	3.4210 to 3.4230-in.
E	3.4372 to 3.4377-in.	3.4215 to 3.4235-in.

(3) CHECK PISTON PIN BORE.

GAGE, plug, diameter, 0.8591- to 0.8594-in.

Using plug gage, check diameter of piston pin bore. This dimension should be 0.8501 to 0.8594 inch.

(4) CHECK RING GROOVE WIDTH.

Measure ring groove width. The correct dimensions are: No. 1 (top) 0.096 to 0.097 inch, No. 2 0.0955 to 0.0965 inch, Nos. 3 and 4 0.156 to 0.157 inch.

INSPECTION AND REPAIR OF PARTS

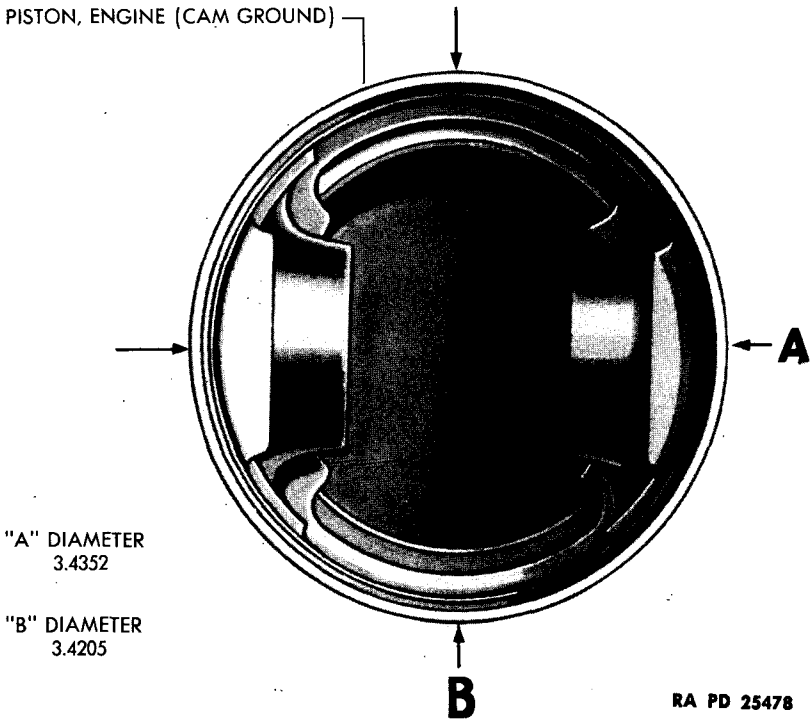


Figure 37 — Piston Diameters

(5) CHECK PISTON RINGS.

(a) Clean And Inspect Visually.

PAN, for cleaning

Wash rings thoroughly in SOLVENT, dry-cleaning, removing all foreign matter, to permit close inspection. Inspect rings carefully for cracks.

(b) Measure Ring Width And Gap Between Ends.

GAGE, feeler

MICROMETER, outside, 1-in.

Measure ring width with 1-inch outside micrometer. The width should be, compression rings 0.0930 to 0.935 inch, oil rings 0.1545 to 0.1550 inch. Place piston rings in respective cylinder bore and, with rings square in bore, measure clearance between ends of ring with feeler gage. This clearance should be 0.007 to 0.015 inch on both compression rings and oil rings. Maximum allowable gap, before replacing, 0.030 inch.

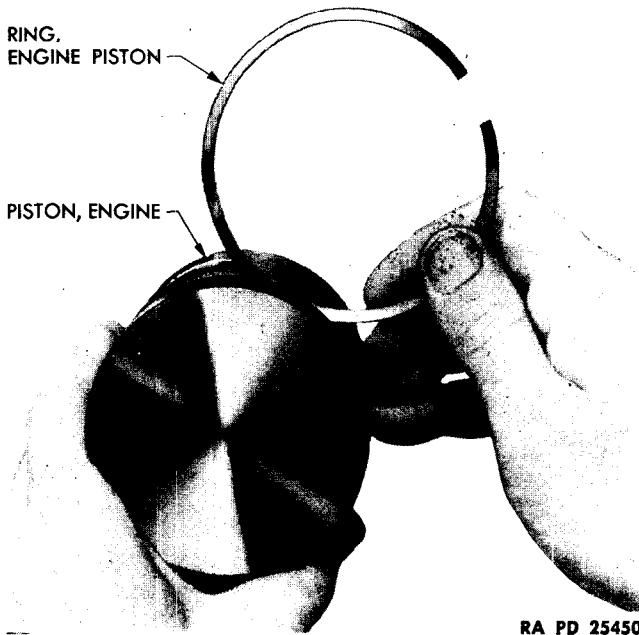
(c) Check Side Clearance Of Rings In Grooves.

GAGE, feeler

TOOL, piston ring installing

Place ring in groove and roll around piston in groove (fig. 38). The

**ORDNANCE MAINTENANCE – POWER UNIT FOR  
MEDIUM TANKS M3A4 AND M4A4**



RA PD 25450

**Figure 38 – Checking Piston Ring Clearance In Groove**

ring should be free at all positions on piston. Using ring installing tool, install rings on piston for further inspection (fig. 39). With rings in position on piston, use a feeler gage to measure side clearance in groove (fig. 40). The correct side clearance is: oil rings 0.001 to 0.002 inch, and should be replaced if beyond 0.004 inch, compression rings, No. 1 (top) 0.0025 to 0.004 inch, No. 2 0.002 to 0.0035 inch, and piston should be replaced if beyond 0.008 inch.

**i. Distributor.**

The inspection of the distributor is covered in paragraph 58.

**j. Clean Manifolds And Inspect Visually.**

AIR, compressed

SCRAPER

Remove all carbon and torn gaskets from mounting faces and wash thoroughly in SOLVENT, dry-cleaning. Inspect mounting faces carefully for any cracks, nicks, or depressions which would prevent a tight gasket seal. Blow out thoroughly with compressed air, removing any loose particles from inside manifolds. Inspect outside of manifolds for cracks or leaks. Inspect all threads to be sure they are free from damage and that openings are free from obstructions.

INSPECTION AND REPAIR OF PARTS

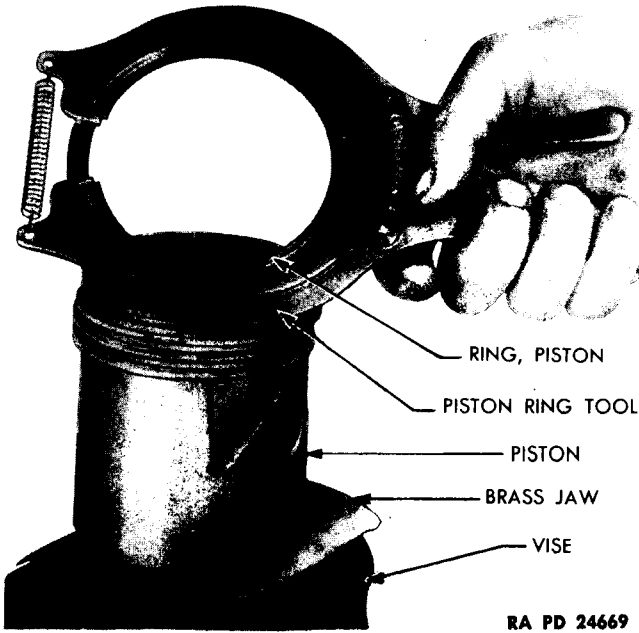


Figure 39 — Installing Piston Rings

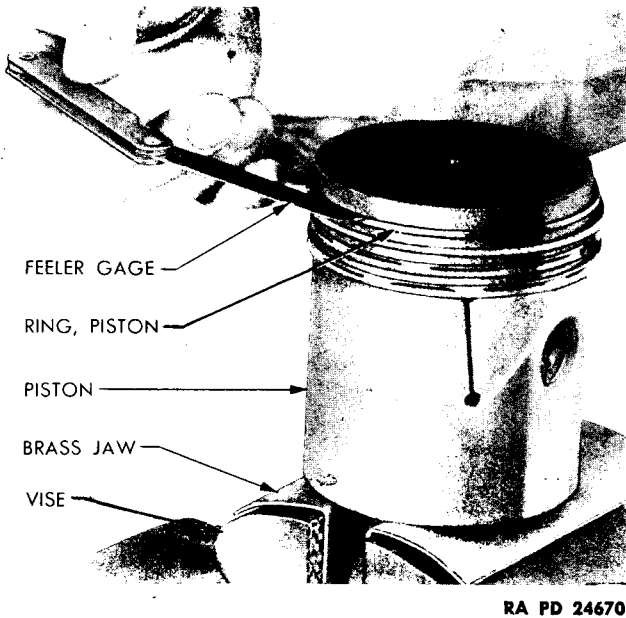


Figure 40 — Measuring Piston Ring Side Clearance

**ORDNANCE MAINTENANCE — POWER UNIT FOR  
MEDIUM TANKS M3A4 AND M4A4**

**k. Accessory Drive Shaft And Support.**

BLOCK, "V"	MICROMETER, outside, 1-in.
FILE	MICROMETER, outside, 1- to 2-in.
GAGE, plug, 1.2515- to 1.2525-in.	WHETSTONE
INDICATOR, dial and mounting	

Using 1- to 2-inch outside micrometer, measure bearing diameters on drive shaft, and, if diameters are less than 1.249 inch, replace shaft. Using 1-inch outside micrometer, measure diameters on shaft which receive the accessory drive shaft gears and, if diameters are less than 0.9995 inch replace shaft. Using 1-inch outside micrometer, measure the diameter of shaft which receives the fuel pump drive sleeve and, if diameter is less than 0.5630 inch, replace shaft. Inspect threads, keyways, and splines for damage, removing any nicks with a fine file or whetstone. Rest accessory shaft on V-blocks and, with dial indicator, take a reading on all bearing surfaces. If more than 0.002 inch eccentric with each other, replace shaft. Using plug gage, measure the inside diameter of bushings in support (one at each end) and, if worn beyond 1.2525 inch, replace with new bushings.

**20. REPAIR OF COMPONENTS.**

**a. Cylinder Bore Reconditioning.**

FEELER, 0.003-in. x 1/2-in.	MICROMETER, outside, 3- to 4-in.
GAGE, cylinder, universal, Federal Stock No. 41-G-122	SCALE
HONE, cylinder	TOOL, reboring

**(1) REBORE CYLINDERS.**

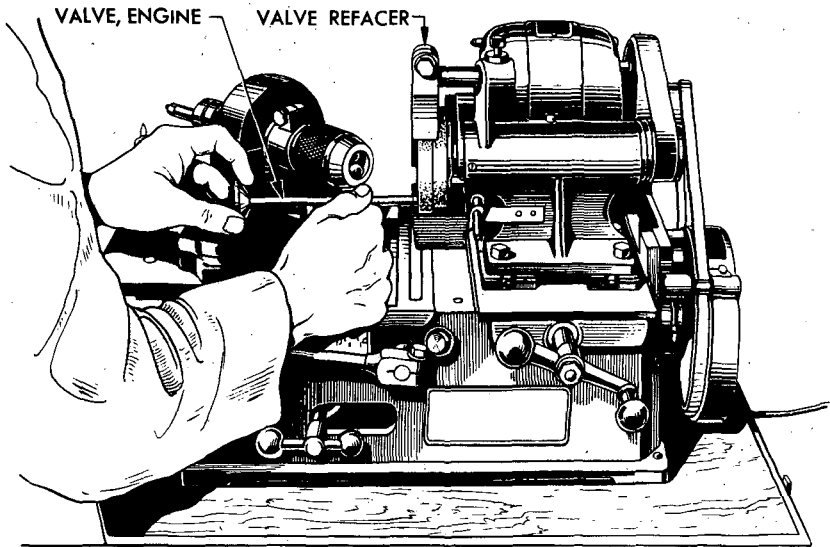
GAGE, cylinder, universal, Federal Stock No. 41-G-122	MICROMETER, outside 3- to 4-in.
HONE, cylinder	TOOL, reboring

(a) Inspect top of cylinder block to be sure it is smooth and free from any irregularities which will not permit reboring tool to mount square on block.

(b) Mount reboring tool on block. Unless tool is mounted square on block, the cylinder will not be rebored at right angles to top of block, resulting in misalignment of cylinder bore and crankshaft.

(c) Rebore cylinder to within 0.001 inch of finished dimension. Determine diameter of piston to be used in bore and polish bore with

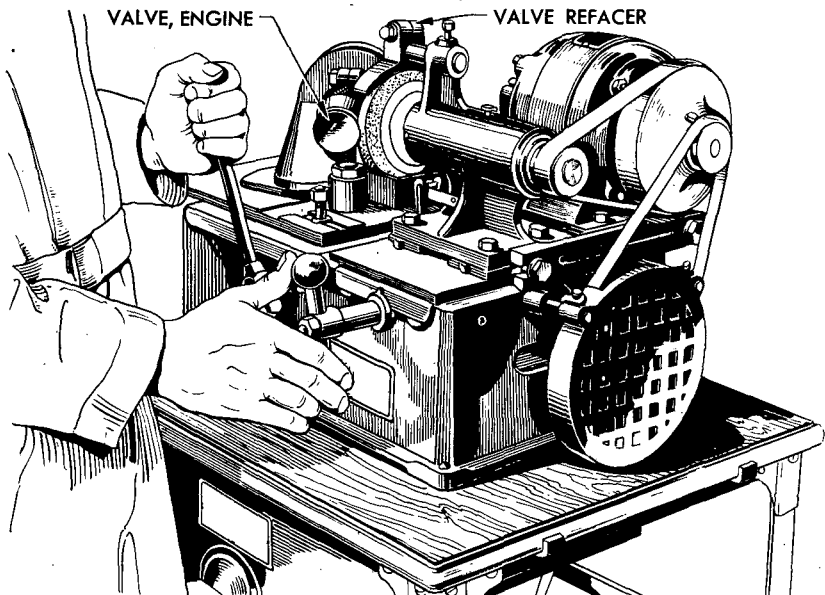
### INSPECTION AND REPAIR OF PARTS



RA PD 25439

**Figure 41 — Grinding End Of Valve Stem**

hone to allow 0.0018- to 0.0024-inch clearance between bore and piston skirt. Check clearance by placing a feeler (0.003-in. thick, 1/2-in. wide) in cylinder bore and inserting piston in bore, with feeler on thrust side



RA PD 25447

**Figure 42 — Refacing Valve**

ORDNANCE MAINTENANCE — POWER UNIT FOR  
MEDIUM TANKS M3A4 AND M4A4

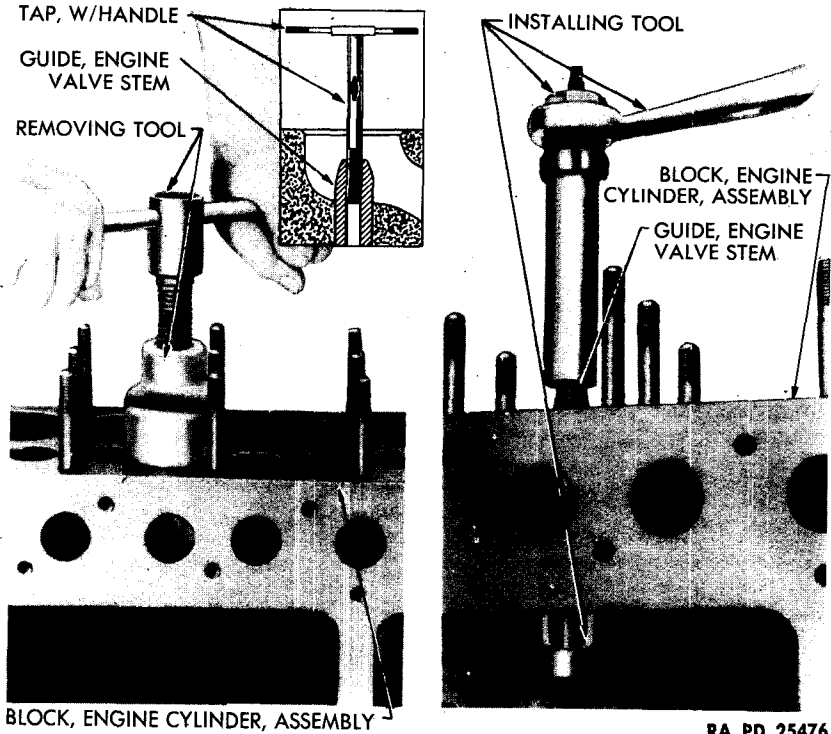


Figure 43 — Removing And Installing Valve Guides

of piston. Attach spring scale to feeler and remove feeler. When properly fitted, 5 to 8 pounds are required to remove feeler. **NOTE:** When the re-boring and polishing operation is completed, a good job should not show more than 0.0005-inch out-of-round nor more than 0.0005-inch taper.

(d) Wash cylinder bores thoroughly, after completing re-boring operation, to remove all foreign matter.

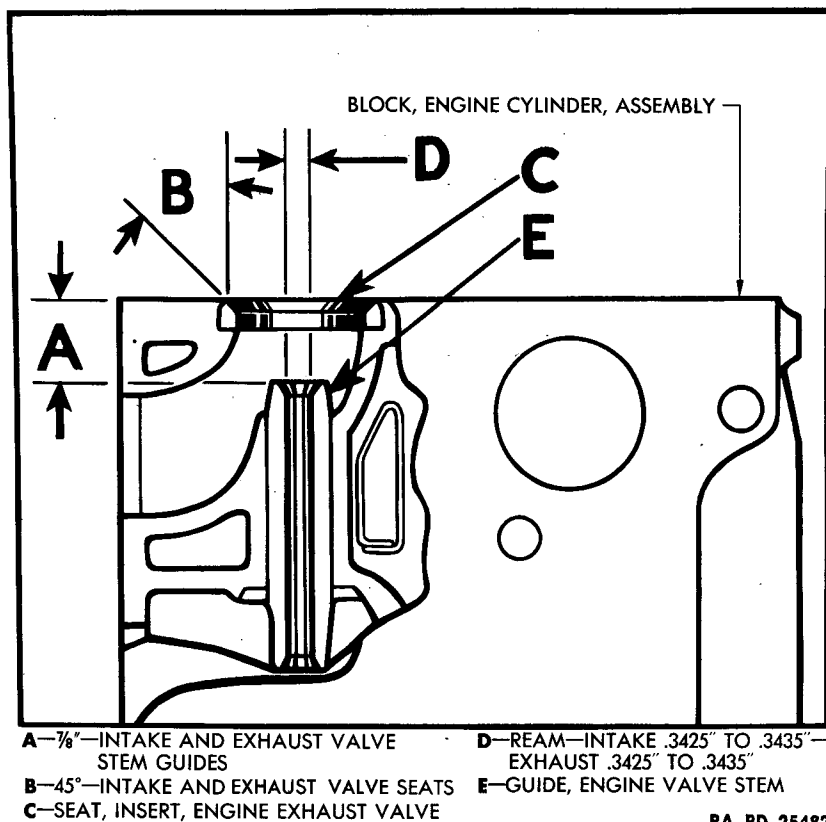
**b. Reface Valves.**

**REFACER**, valve, Federal Stock No. 40-V-505

(1) Using special holding fixture on valve refacer, grind end of valve stem to remove any irregularities (fig. 41).

(2) Place valve in refacer and grind seat until it is concentric with stem (fig. 42). Be sure to grind to 45-degree angle. After grinding, place valves in proper position in board, to assure reassembling in respective opening in cylinder block and to eliminate damage to valve.

## INSPECTION AND REPAIR OF PARTS



**Figure 44 — Location Of Valve Stem Guides**

**c. Remove Valve Guide (fig. 43).**

TOOL, special, No. CM-83

Using tap, cut threads in upper end of guide, to receive removing tool. Attach removing tool and remove guide from block.

**d. Install Valve Guide.**

REAMER, expansion

TOOL, special, No. CM-83

Place new guide in position, with chamfered end up, and install in block with installing tool (fig. 43). Be sure that the distance from top of cylinder block to top of guide measures exactly  $\frac{7}{8}$  inch (fig. 44). Using expansion reamer, ream-guide to give proper clearance with valve being used, intake 0.001 to 0.003 inch, exhaust 0.003 to 0.005 inch.

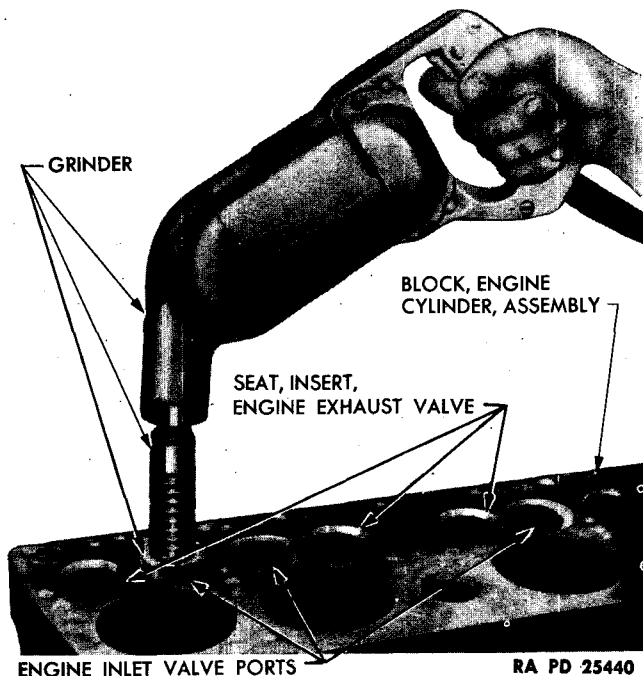
**e. Regrind Valve Seat Inserts.**

GRINDER, valve seat, Federal  
 Stock, No. 40-V-530

INDICATOR, dial



## ORDNANCE MAINTENANCE – POWER UNIT FOR MEDIUM TANKS M3A4 AND M4A4



**Figure 45 – Grinding Valve Seat Insert**

**(1) INSTALL VALVE GUIDE PILOT IN VALVE GUIDE.**

Clean valve stem guides thoroughly, removing all carbon. Chamfer upper end of valve guides. Fit guide pilot snugly in guide and tighten securely.

**(2) GRIND SEAT (To 45-degree Angle).**

True grinding stone for concentricity on diamond dressing tool. Operate grinding stone dry, to maintain proper grinding speed, and grind seats to remove all irregularities (fig. 45). Check seat with dial indicator. Eccentricity must not be over 0.0015 inch (total indicator reading). **CAUTION:** Do not use valve grinding compound on valve seat insert.

**f. Recut Intake Valve Seat.**

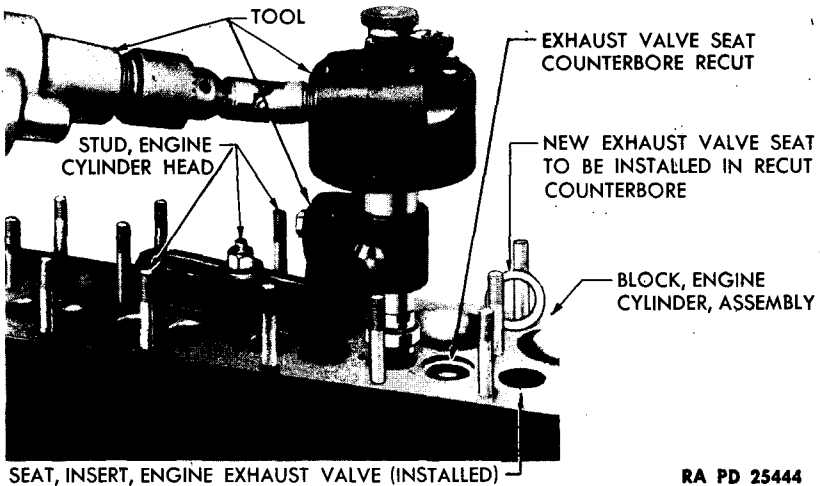
**CUTTER, 45-degree**

**INDICATOR, dial**

**(1) RECUT SEAT.**

Using 45-degree cutter, cut seat sufficiently to remove any irregularities. Check seat with dial indicator. Eccentricity must not be over 0.0015 inch (total indicator reading).

INSPECTION AND REPAIR OF PARTS



RA PD 25444

Figure 46 — Installing Valve Seat Insert

**g. Remove Valve Seat Insert.**

**PULLER**, valve seat insert

Using puller, remove seat from cylinder block.

**h. Install Seat.**

**TOOL**, valve seat insert replacing,  
Federal Stock No. 41-T-3383

Using counterboring tool, with cutter diameter 1.5215-inch counterbore opening in cylinder block to receive 0.010-inch oversized seat insert, outside diameter 1.525 inch. This dimension allows 0.0035 inch press fit in opening (fig. 46). Chill insert with dry ice to obtain maximum contraction, thus permitting the insert to be readily installed. Grind seat, as outlined in paragraph 20 e.

**i. Remove Welch Plugs.**

**HAMMER**

**PUNCH**, center

Welch plugs are installed in various parts of the engine and will require replacing only when there is evidence of leakage. Using hammer and center punch, drive in the center, collapsing plug, and it will fall out of place.

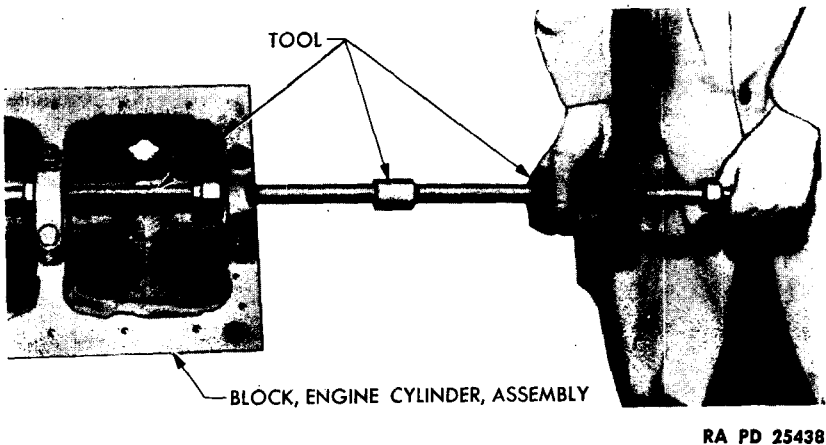
**j. Install Welch Plug.**

**DRIFT**

**HAMMER**

Clean seat, removing any rust or dirt, and be sure seat is smooth. Be sure plug is free from sharp edges and irregularities. Place white lead or sealing compound on plug and place in position in opening, with curved

**ORDNANCE MAINTENANCE – POWER UNIT FOR  
MEDIUM TANKS M3A4 AND M4A4**



RA PD 25438

**Figure 47 – Removing And Installing Camshaft Bearings**

or crowned side of plug on outside. Using a blunt drift and hammer, expand by flattening plug in opening. Never reinstall a plug which has been removed from block.

**k. Remove Camshaft Bearings.**

TOOL, removing, No. C-536

Position removing tool in cylinder block and remove No. 1 bearing (from distributor end of block). Repeat operation to remove bearings Nos. 2 and 3.

**l. Install Camshaft Bearings.**

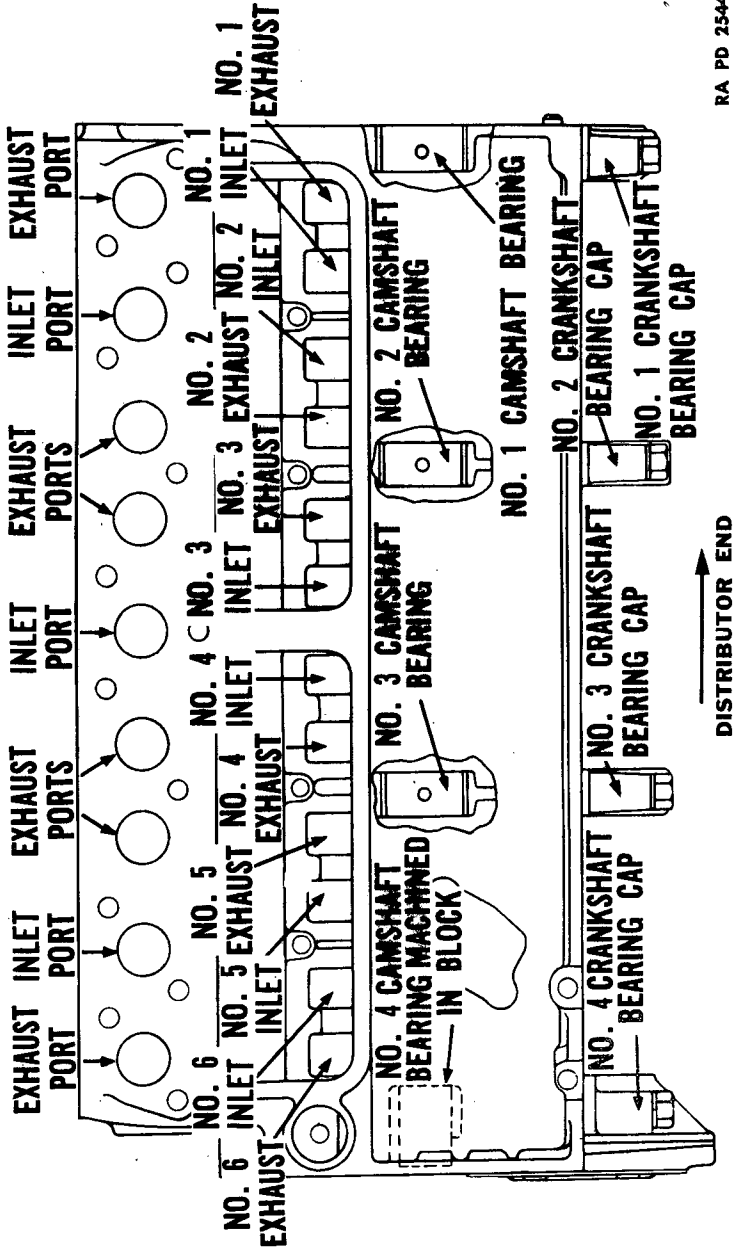
TOOL, installing, No. C-536

**(1) INSTALL NO. 3 BEARING (fig. 47).**

TOOL, installing, No. C-536

Position bearing on tool. Coat outside of bearing with white lead. Insert tool and bushing through camshaft bearing openings Nos. 1 and 2. Install No. 1 bearing pilot in No. 1 bearing opening around installing tool handle. Place No. 3 bearing pilot and bushing on front edge of opening in cylinder block, making sure that oilhole in bearing will aline with oilhole in bearing opening when bearing is installed. Insert tool through No. 3 camshaft bearing pilot and drive bearing into opening until both edges are flush with edges of opening. *Check oilholes, to be sure they aline properly.* Withdraw installing tool from No. 2 bearing, but leave it in place in No. 1 bearing pilot. Remove pilot from No. 3 bearing.

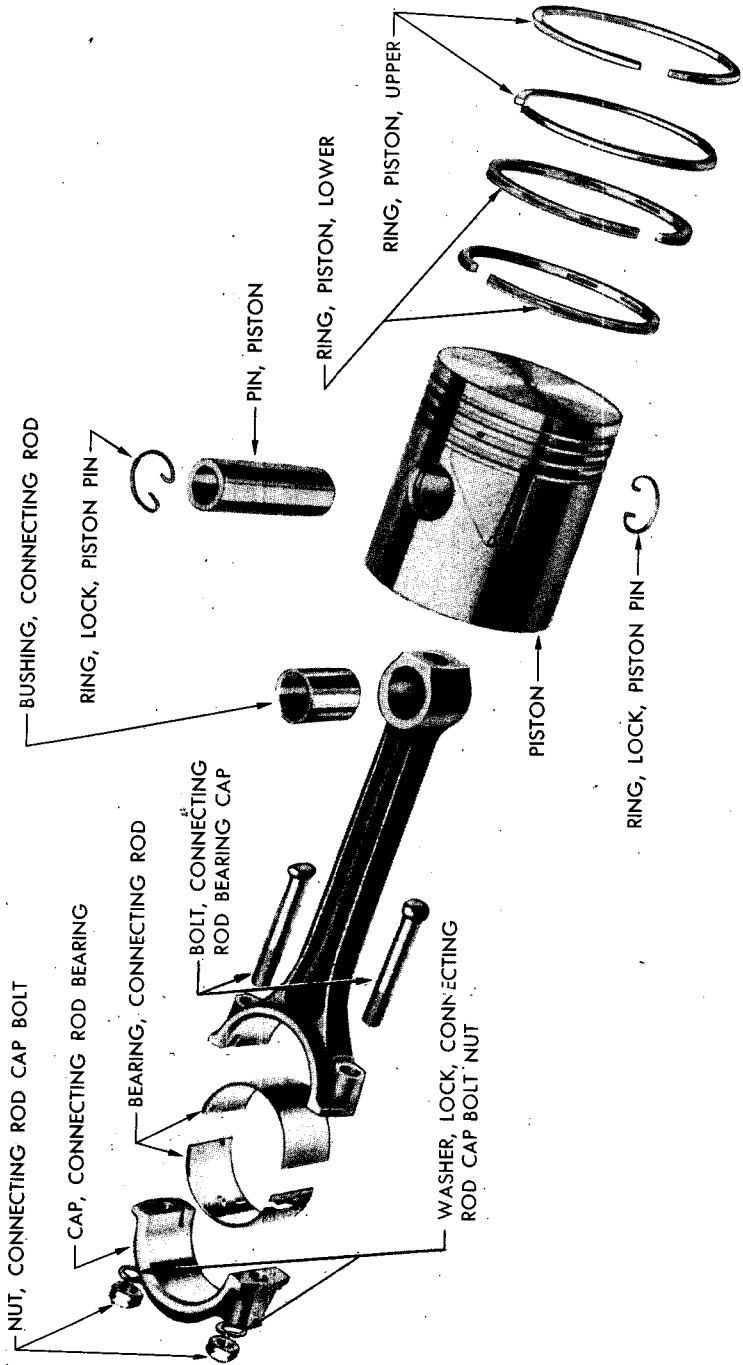
INSPECTION AND REPAIR OF PARTS



RA PD 25443

Figure 48 — Cylinder Block Diagram

ORDNANCE MAINTENANCE — POWER UNIT FOR  
MEDIUM TANKS M3A4 AND M4A4



RA PD 25341

Figure 49 — Piston And Connecting Rod, Exploded

## INSPECTION AND REPAIR OF PARTS

### (2) INSTALL NO. 2 BEARING (fig. 47).

TOOL, installing, No. C-536

Position No. 2 bearing on pilot. Coat outside surface of bearing with white lead. Place No. 2 bearing pilot and bearing on front edge of No. 2 bearing opening in cylinder block, making sure that oilhole in bearing will aline with oilhole in cylinder block when bearing is installed. Insert tool through No. 2 bearing pilot and drive bearing into opening until both edges are flush with edges of opening. *Check oilholes to be sure they are properly alined.* Remove installing tool and No. 1 bearing pilot from cylinder block, but leave No. 2 bearing pilot in place.

### (3) INSTALL NO. 1 BEARING (fig. 47).

TOOL, installing, No. C-536

Position No. 1 bearing on pilot with figure "1" on edge of bearing, facing cylinder block. Coat outside of bushing with white lead. Place pilot and bearing on front edge of No. 1 bearing opening in cylinder block, making sure that oilholes in bearing will aline with oilholes in opening in cylinder block when installed. Insert installing tool through No. 1 and No. 2 bearing pilots and drive bearing into place until ends of bearing are flush with ends of opening. *Check oilholes to be sure they are properly alined.* Remove tool and pilots.

## 21. DISASSEMBLY OF COMPONENTS.

### a. Disassemble Piston And Connecting Rod (fig. 49).

PLIERS, diagonal

TOOL, piston ring remover

#### (1) REMOVE PISTON RINGS (fig. 39).

TOOL, piston ring remover

Using piston ring removing tool, expand ring sufficiently to clear ring grooves in piston and lift ring off piston. Use care when expanding ring. If expanded too far there is danger of breakage.

#### (2) REMOVE PISTON FROM CONNECTING ROD.

PLIERS, diagonal

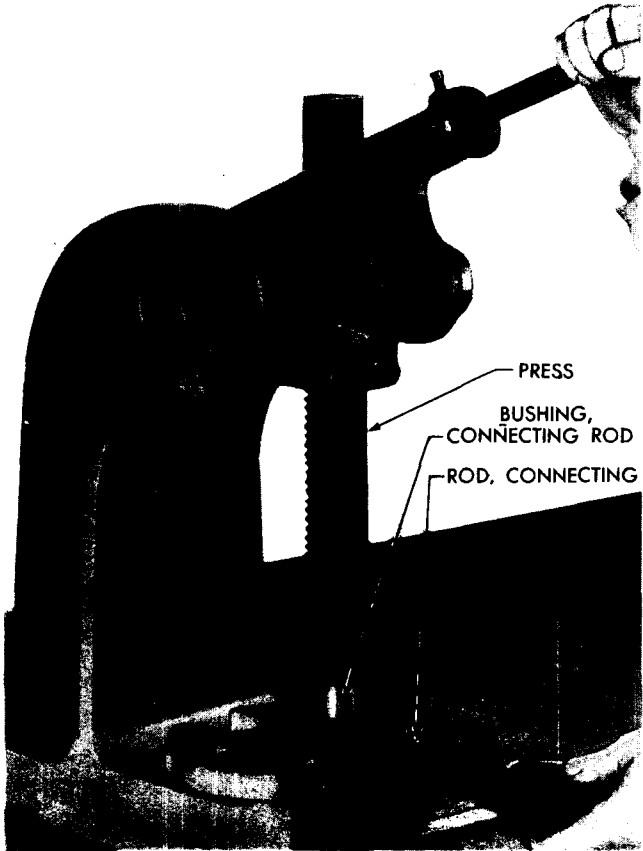
Remove piston ring lock rings (one at each end of piston pin (fig. 54) ) and push piston pin out of piston and rod.

### b. Disassemble Intake And Exhaust Manifold.

WRENCH,  $\frac{3}{16}$ -in.

Remove 4 nuts and pal nuts and separate manifolds by withdrawing 4 bolts (4 studs engine No. 4) (fig. 66).

ORDNANCE MAINTENANCE — POWER UNIT FOR  
MEDIUM TANKS M3A4 AND M4A4



RA PD 25318

*Figure 50 — Installing Bushing In Connecting Rod*

**c. Disassemble Intake Manifold.**

WRENCH,  $\frac{9}{16}$ -in.

Remove elbow (Nos. 2, 3, 4, and 5 only) by removing 4 nuts and lock washers and separate elbow from intake manifold studs (fig. 66).

**d. Remove Manifold Heat Control Valve And Thermostat.**

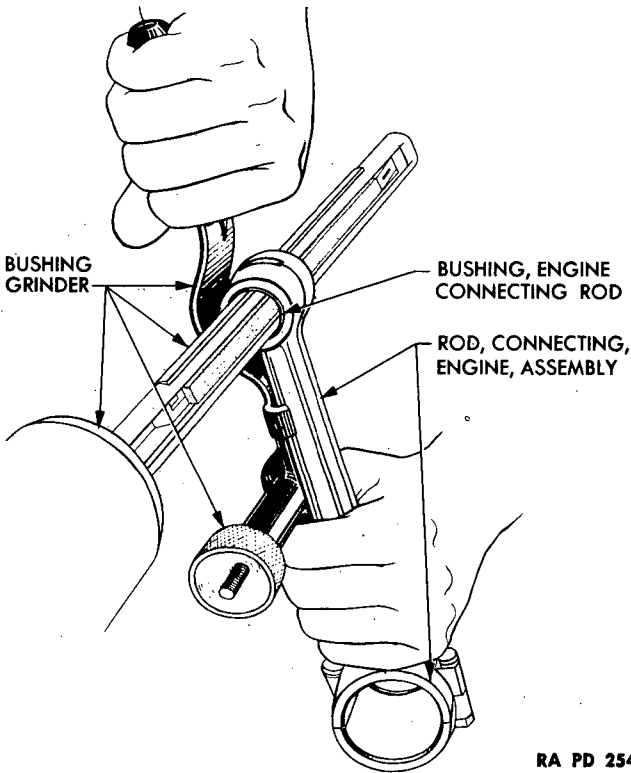
PRESS

WRENCH, open-end,  $\frac{3}{8}$ -in.

SCREWDRIVER

Remove nut and lock washer ( $\frac{3}{8}$ -in. open-end wrench) and remove cap screw (screwdriver) from counterweight releasing stop assembly. Lift counterweight off shaft (fig. 63). Remove lock from slot in shaft and lift thermostat off shaft (fig. 61). Lift spacer off shaft (fig. 60). Should it be necessary to replace the heat control valve assembly (plate

INSPECTION AND REPAIR OF PARTS



RA PD 25454

**Figure 51 — Grinding Connecting Rod Bushing**

spot-welded to shaft) withdraw shaft after plate has been forced off shaft (fig. 59). Remove slotted stud from manifold (necessary only if to be replaced). Place manifold in press (fig. 58) and force out bushing. (This is only necessary if bushings are worn and are to be replaced.)

**22. ASSEMBLY OF COMPONENTS.**

**a. Assemble Connecting Rod And Piston.**

**ALINER**, connecting rod, uni-  
versal, Federal Stock, No.  
41-A-135

**GRINDER**, bushing, Federal  
Stock, No. 40-G-103

**PLIERS**, diagonal

**PRESS**, bench

**PRESS**, hydraulic, connecting  
rod, Federal Stock,  
No. 41-P-2730

**NOTE:** If new connecting rods and/or new pistons are to be installed they must be in matched sets, not to exceed 1/4 ounce for either a set of connecting rods or a set of pistons.





INSPECTION AND REPAIR OF PARTS

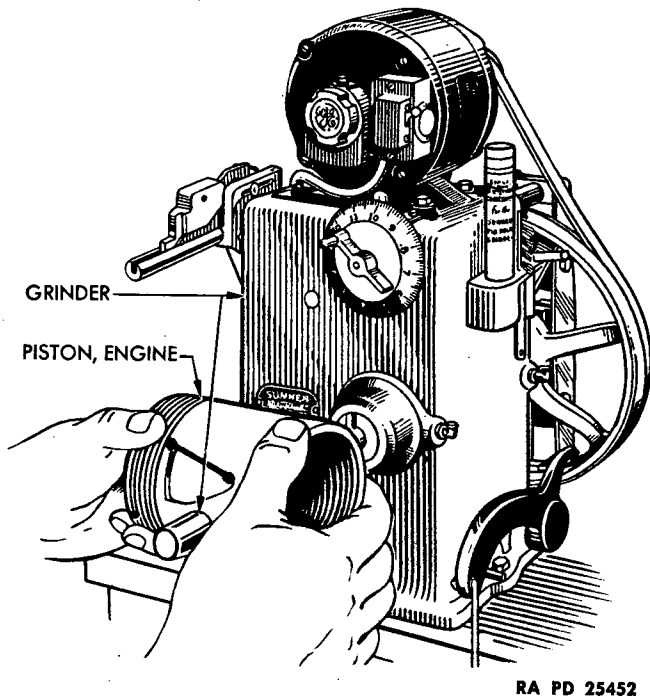


Figure 53 — Griding Piston Pin Bores In Piston

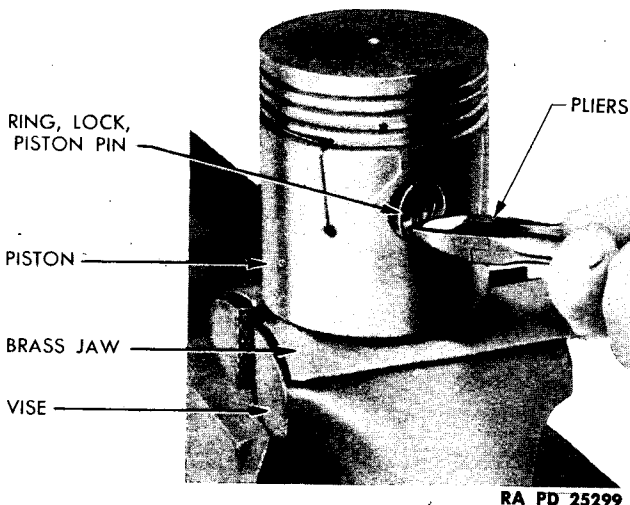
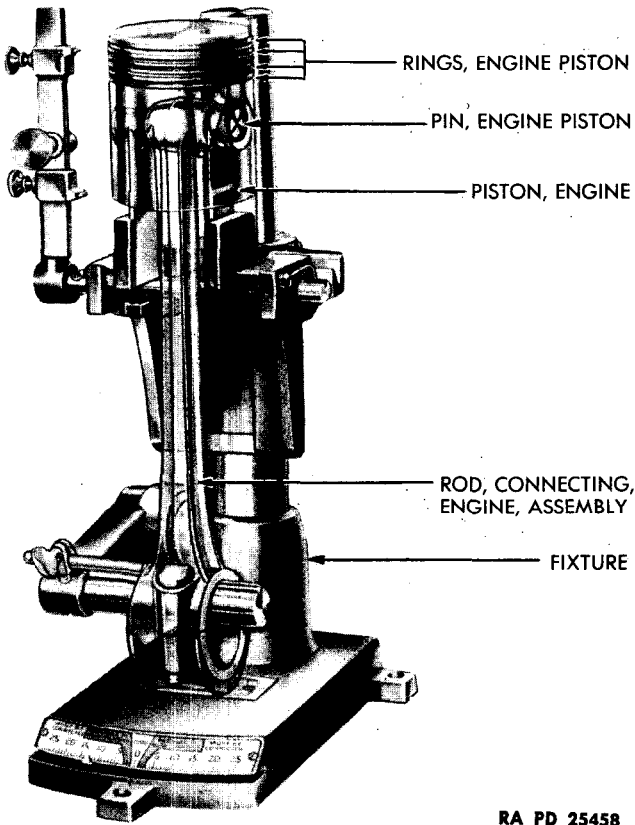


Figure 54 — Installing Piston Pin Lock Ring

**ORDNANCE MAINTENANCE — POWER UNIT FOR  
MEDIUM TANKS M3A4 AND M4A4**



RA PD 25458

**Figure 55 — Checking Connecting Rod Alinement**

end of pin, being sure rings are seated in grooves in piston pin boss (fig. 54).

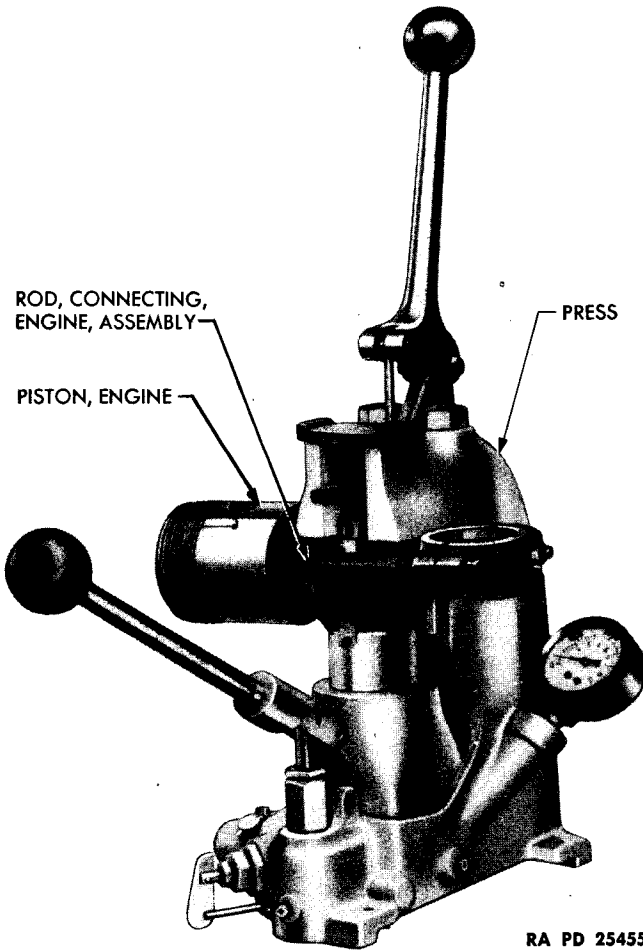
**(5) ALINE CONNECTING ROD.**

**ALINER**, connecting rod, uni-  
versal, Federal Stock No.  
41-A-135

**PRESS**, hydraulic, connecting  
rod, Federal Stock No.  
41-P-2730

Using alining fixture, check alinement of connecting rod and (fig. 55), if necessary, straighten with straightening press (fig. 56). Alinement of rod should be held to 0.003 inch, measured on side of piston.

INSPECTION AND REPAIR OF PARTS



RA PD 25455

**Figure 56 – Straightening Connecting Rod**

**b. Assemble Exhaust Manifold (fig. 57).**

**DRIVER**, special, 0.305-in.

**EQUIPMENT**, welding

**PRESS**

**REAMER**, line, 0.309- to  
0.3105-in. to 0.311- to  
0.3125-in.

**SCREWDRIVER**

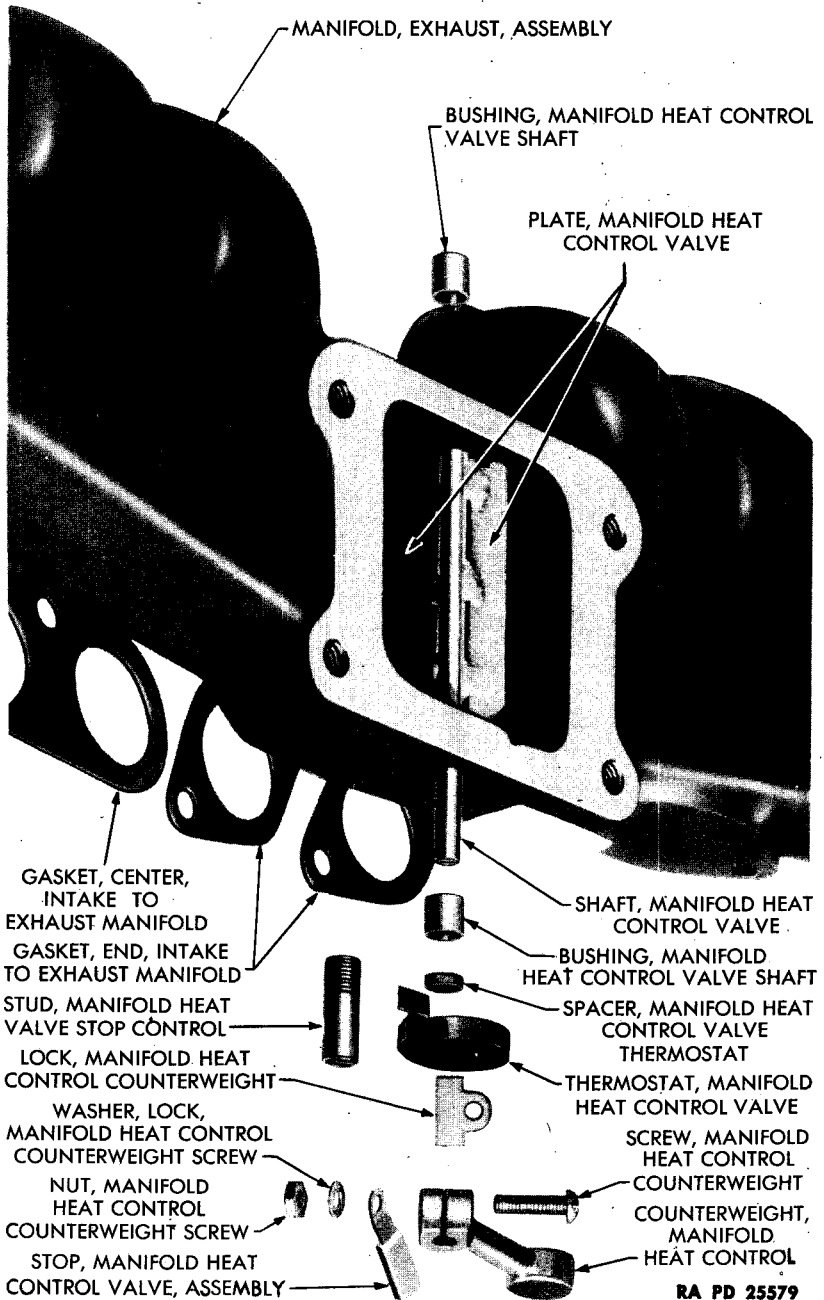
**WRENCH**,  $\frac{9}{16}$ -in.

**WRENCH**,  $\frac{5}{8}$ -in.

**WRENCH**, open-end,  $\frac{3}{8}$ -in.

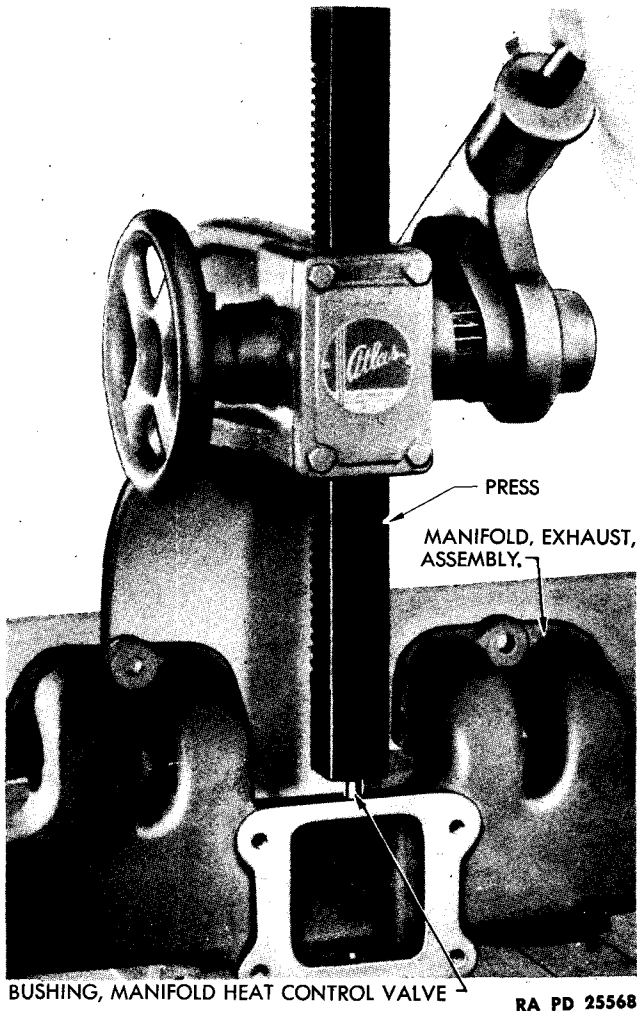
**WRENCH**, torque

**ORDNANCE MAINTENANCE – POWER UNIT FOR  
MEDIUM TANKS M3A4 AND M4A4**



**Figure 57 – Manifold Automatic Heat Control Valve, Exploded**

## INSPECTION AND REPAIR OF PARTS



**Figure 58 — Installing Heat Control Shaft Bushings**

**(1) INSTALL HEAT CONTROL VALVE SHAFT BUSHINGS.**

**DRIVER**, bushing  
**PRESS**

**REAMER**, line, 0.309- to  
0.3105-in. to 0.311- to  
0.3125-in.

With driver inserted in bushing to prevent collapse of bushing, press both bushings in place, locating bushings so as to permit  $\frac{1}{2}$ -inch end play in plate when plate and shaft are installed. Using line reamer, ream both bushings at same time, rear bushing on engines Nos. 1, 2, 3, and 5 and

**ORDNANCE MAINTENANCE — POWER UNIT FOR  
MEDIUM TANKS M3A4 AND M4A4**

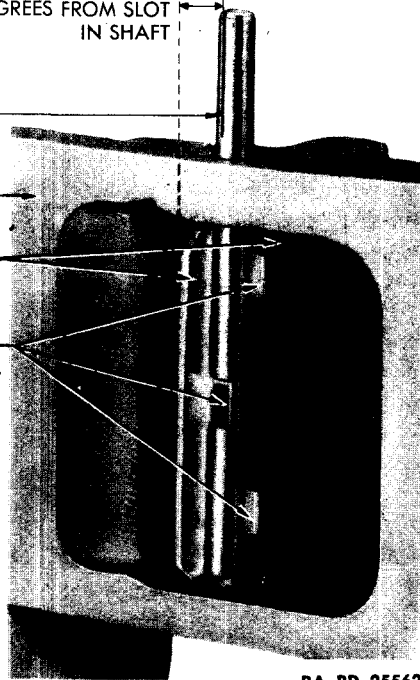
LOCATE PLATE 20 DEGREES FROM SLOT  
IN SHAFT

SHAFT,  
MANIFOLD HEAT  
CONTROL VALVE

MANIFOLD,  
EXHAUST, ASSEMBLY

PLATE, MANIFOLD  
HEAT CONTROL  
VALVE

ARC WELD AT THREE  
POINTS WITH NO. 304  
WELDING ROD FOR  
RUSTLESS STEEL



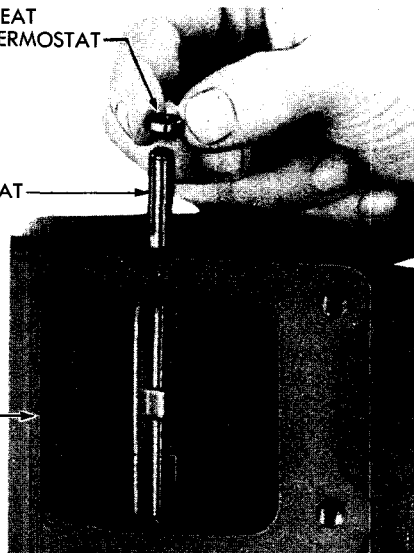
RA PD 25562

**Figure 59 — Manifold Heat Control Valve Plate And Shaft In Position  
For Welding**

SPACER, MANIFOLD HEAT  
CONTROL VALVE THERMOSTAT

SHAFT, MANIFOLD HEAT  
CONTROL VALVE

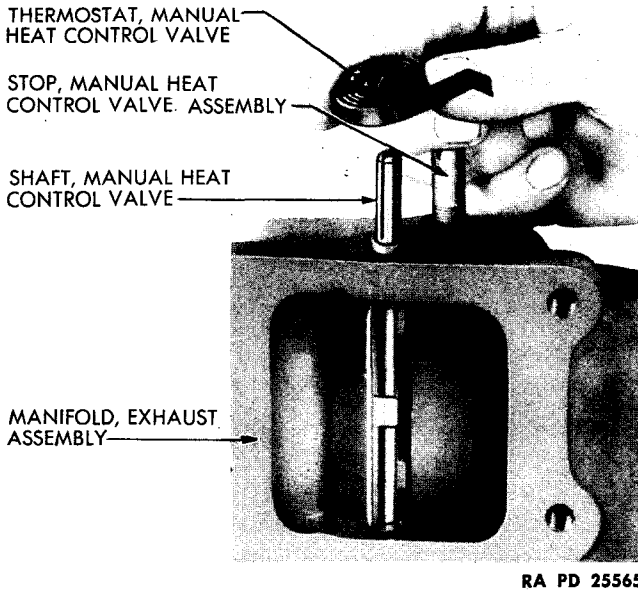
MANIFOLD, EXHAUST,  
ASSEMBLY



RA PD 25567

**Figure 60 — Installing Thermostat Spacer**

**INSPECTION AND REPAIR OF PARTS**



RA PD 25565

**Figure 61 — Installing Thermostat**

bottom bushing on engine No. 4 0.311 to 0.3125 inch; front bushing on engine Nos. 1, 2, 3, and 5 and top bushing on engine No. 4 0.309 to 0.3105 inch. (This is necessary only if new bushings are to replace worn bushings.)

**(2) INSTALL HEAT CONTROL VALVE.**

**EQUIPMENT, welding**

If new assembly is necessary, place shaft in position and arc-weld plate and shaft together on both sides of plate. **NOTE:** The plate is positioned 20 degrees clockwise off center of slot in shaft (on manifolds 1, 2, 3, and 5, and 59 degrees counterclockwise off center of slot in shaft on No. 4 engine manifold) before welding (fig. 59). This is necessary on account of balancing thermostat mechanism.

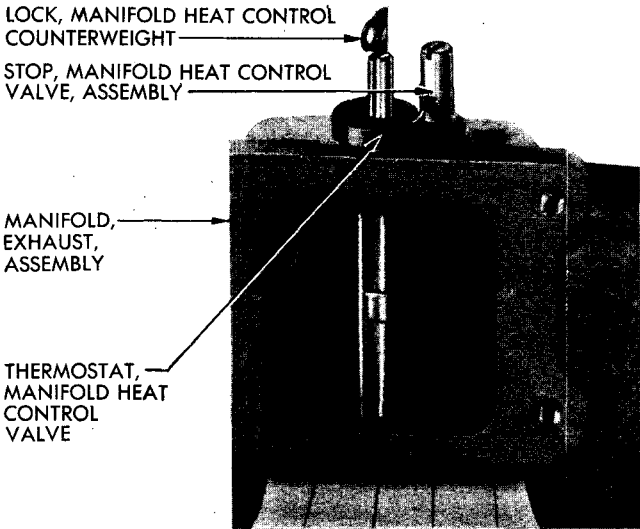
**(3) INSTALL MANUAL HEAT CONTROL VALVE THERMOSTAT.**

**SCREWDRIVER**

Position spacer in position on shaft (fig. 60). Screw new manual heat control valve assembly stop screw into opening in manifold (screwdriver) (fig. 61). Position new thermostat on shaft (fig. 61) inserting lip at center of thermostat in slot in shaft (in a position to give a wrap of  $1\frac{1}{3}$  turns) and with end of thermostat contacting stop (fig. 62).



**ORDNANCE MAINTENANCE — POWER UNIT FOR  
MEDIUM TANKS M3A4 AND M4A4**



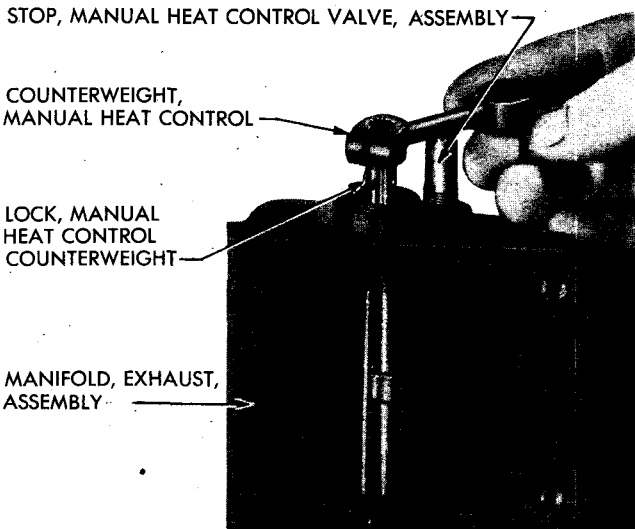
RA PD 25561

**Figure 62 — Installing Counterweight Lock — Lip Down**

**(4) INSTALL COUNTERWEIGHT.**

**WRENCH**, open-end,  $\frac{3}{8}$ -in.

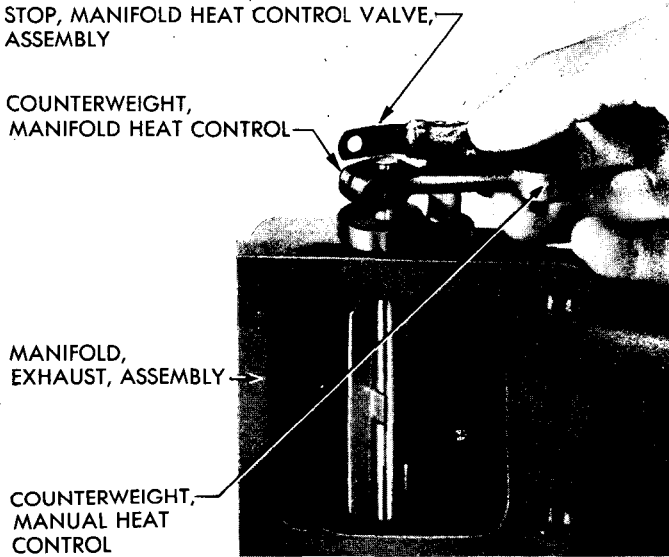
Place *new* counterweight lock in shaft (fig. 63) and install counterweight on shaft (fig. 63). Position *new* stop in slot in shaft so as to (fig. 64) aline holes and install counterweight screw, lock washer, and nut (fig. 65).



RA PD 25564

**Figure 63 — Installing Counterweight**

**INSPECTION AND REPAIR OF PARTS**

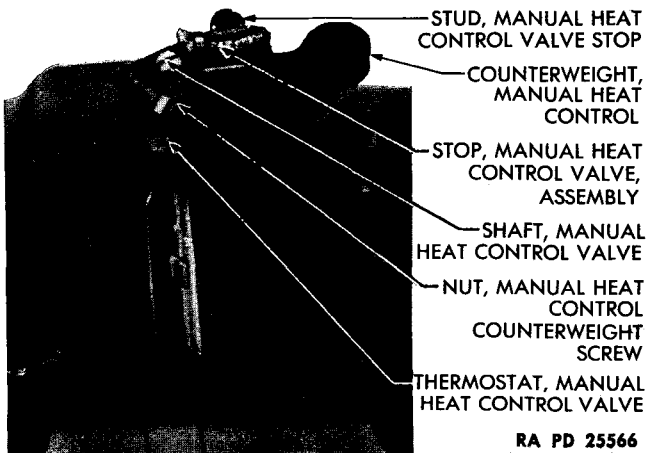


RA PD 25563

**Figure 64 – Installing Stop Assembly**

**(5) TEST FOR OPERATION.**

Work valve plate to make sure that there is no obstruction and that thermostat and parts have been assembled correctly.



RA PD 25566

**Figure 65 – Heat Control Valve Assembly**

ORDNANCE MAINTENANCE — POWER UNIT FOR  
MEDIUM TANKS M3A4 AND M4A4

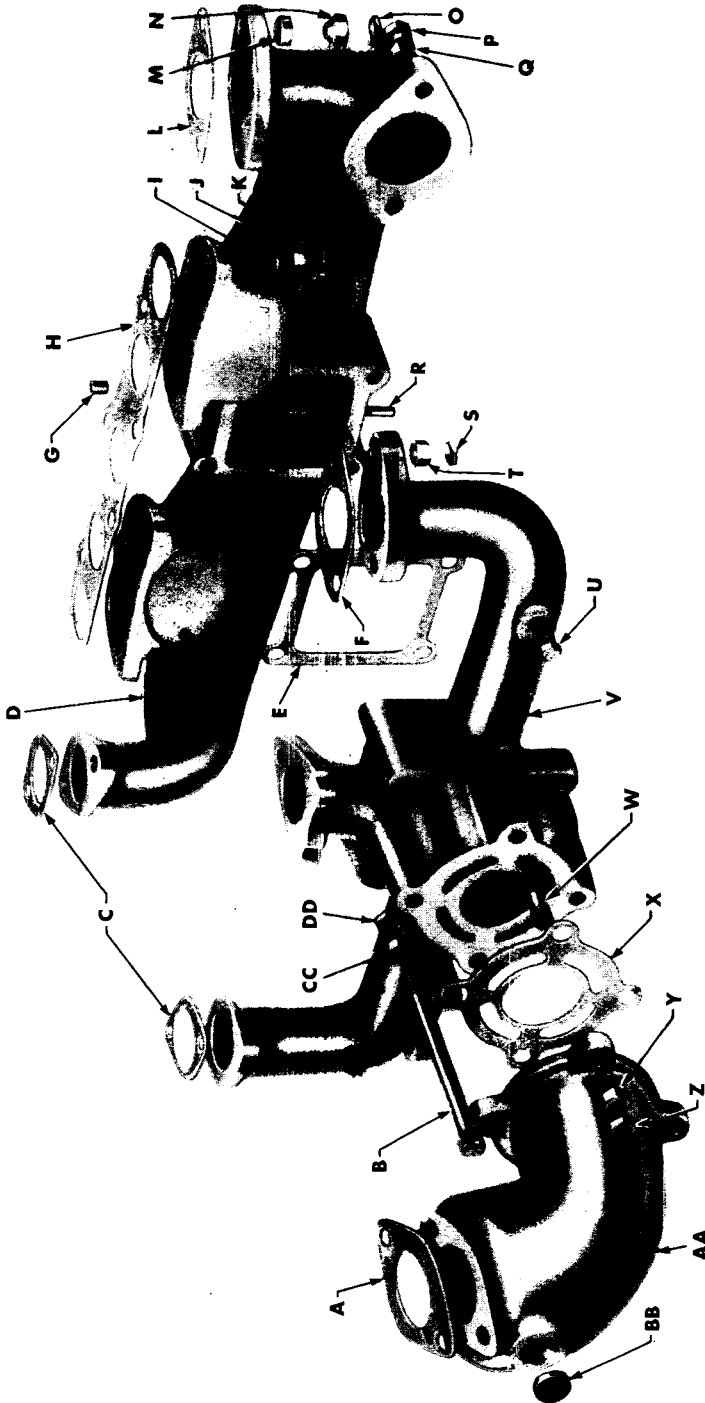


Figure 66 — Exhaust And Intake Manifolds, Exploded

RA PD 300575

INSPECTION AND REPAIR OF PARTS

- A—GASKET, CARBURETOR FLANGE
- B—BOLT, INTAKE TO EXHAUST MANIFOLD
- C—GASKET, END, INTAKE AND EXHAUST MANIFOLD TO CYLINDER BLOCK
- D—MANIFOLD, EXHAUST, ASSEMBLY
- E—GASKET, INTAKE TO EXHAUST MANIFOLD
- F—GASKET, END, INTAKE AND EXHAUST MANIFOLD TO CYLINDER BLOCK
- G—BUSHING, MANIFOLD HEAT CONTROL VALVE SHAFT
- H—GASKET, CENTER, INTAKE AND EXHAUST MANIFOLD TO CYLINDER BLOCK
- I—WASHER, MANIFOLD CLAMP
- J—NUT, MANIFOLD STUD
- K—NUT, LOCK, MANIFOLD STUD
- L—GASKET, END, INTAKE AND EXHAUST MANIFOLD TO CYLINDER BLOCK
- M—WASHER, EXHAUST MANIFOLD STUD NUT
- N—NUT, EXHAUST MANIFOLD STUD
- O—NUT, LOCK, EXHAUST MANIFOLD STUD
- P—NUT, LOCK, EXHAUST PIPE FLANGE BOLT
- Q—NUT, EXHAUST PIPE FLANGE BOLT
- R—SHAFT, MANIFOLD HEAT CONTROL VALVE
- S—NUT, LOCK, INTAKE MANIFOLD STUD
- T—NUT, INTAKE MANIFOLD STUD
- U—PLUG, INTAKE MANIFOLD, PIPE
- V—MANIFOLD, INTAKE, ASSEMBLY
- W—STUD, INTAKE MANIFOLD TO ELBOW
- X—GASKET, INTAKE MANIFOLD TO ELBOW
- Y—NUT, INTAKE MANIFOLD TO ELBOW STUD
- Z—NUT, LOCK, INTAKE MANIFOLD TO ELBOW STUD
- AA—ELBOW, INTAKE MANIFOLD
- BB—PLUG, INTAKE MANIFOLD ELBOW
- CC—NUT, INTAKE TO EXHAUST MANIFOLD BOLT
- DD—NUT, LOCK, INTAKE TO EXHAUST MANIFOLD BOLT

RA PD 300575B

Legend For Figure 66 — Exhaust And Intake Manifolds, Exploded

**ORDNANCE MAINTENANCE — POWER UNIT FOR  
MEDIUM TANKS M3A4 AND M4A4**

**c. Assemble Intake Manifold.**

WRENCH,  $\frac{9}{16}$ -in.

WRENCH, torque

Remove all traces of torn gasket and install new intake manifold to elbow gasket on studs. Position elbow on studs of engines Nos. 2, 3, 4, and 5, and secure with 4 nuts and lock nuts and tighten to 35 to 40 foot-pounds with torque wrench.

**d. Assemble Intake Manifold To Exhaust Manifold (fig. 66).**

WRENCH,  $\frac{9}{16}$ -in.

Remove all traces of torn gaskets and position new gasket. Assemble intake manifold to exhaust manifold with 4 bolts and nuts. NOTE: Leave nuts loose until manifold is assembled on engine, to permit proper alining of manifold mounting faces to cylinder block.

**e. Install Bushings In Accessory Drive Shaft Support.**

DRILL,  $\frac{1}{4}$ -in.

REAMER, line, special (with pilot bushings in both ends of crankcase) 1.2515- to 1.2525-in.

PRESS

Place bushing in edge of opening in support so that groove in bushing will be in bottom of support, as shown in figure 133, when installed. Press bushing into support to point where end of bushing is 0.002 to 0.004 inch below face of support. Insert  $\frac{1}{4}$ -inch drill through opening in support which receives the locating dowel (in crankcase) and drill  $\frac{1}{4}$ -inch hole in each side of bushing, being sure that hole in bushing coincides with drilled passage in support to oilhole in end of support, as shown in figure 132. Repeat operation to install bushing in other end of support. Position support in crankcase and secure with 4 bolts. Using special line reamer (with bushings in openings at each end of crankcase), line-ream both bushings to 1.2515 to 1.2525 inch. Check oilholes to be sure they are free from obstructions.

Section VII

ASSEMBLY OF INDIVIDUAL ENGINE

Paragraph

Assemble engine ..... 23

23. ASSEMBLE ENGINE.

a. Equipment.

- |                                      |                                       |
|--------------------------------------|---------------------------------------|
| BAR, steel                           | WRENCH, $\frac{7}{16}$ -in.           |
| DRIFT                                | WRENCH, $\frac{1}{2}$ -in.            |
| DRIVER and REMOVER,<br>stud          | WRENCH, 1-in.                         |
| GUN, grease                          | WRENCH, 1 $\frac{1}{8}$ -in.          |
| HAMMER, 1-lb                         | WRENCH, extension, 6-in.              |
| HAMMER, brass                        | WRENCH, open-end, $\frac{7}{16}$ -in. |
| HAMMER, steel                        | WRENCH, open-end, $\frac{1}{2}$ -in.  |
| HAMMER, rawhide                      | WRENCH, open-end, $\frac{9}{16}$ -in. |
| LIFTER, valve                        | WRENCH, open-end, $\frac{3}{4}$ -in.  |
| OILCAN                               | WRENCH, socket, $\frac{9}{16}$ -in.   |
| PLIERS, side cutting                 | WRENCH, socket, $\frac{11}{16}$ -in.  |
| PUNCH, prick                         | WRENCH, socket, $\frac{3}{4}$ -in.    |
| SCREWDRIVER                          | WRENCH, socket, 1 $\frac{1}{2}$ -in.  |
| SLEEVE, piston installing            | WRENCH, spanner,<br>MTM-A4-7          |
| TOOL, installing, crankshaft<br>gear | WRENCH, tappet, $\frac{7}{16}$ -in.   |
| TOOL, installing, hub                | WRENCH, tappet, $\frac{1}{2}$ -in.    |
| TOOL, special, No. C-536             | WRENCH, torque                        |

NOTE: The following operations are based on the assumption that all parts, and subassemblies, of the individual engine have been properly reconditioned, as outlined in paragraphs 18 to 22 inclusive.

b. Procedure.

(1) INSTALL CRANKSHAFT, BEARINGS, AND CAPS.

- |                 |                |
|-----------------|----------------|
| BAR, steel      | WRENCH, 1-in.  |
| HAMMER, rawhide | WRENCH, torque |

Oil stems of valve tappets and insert them in respective openings in cylinder block (fig. 68). Fit crankshaft bearings in respective locations in cylinder block, being sure to fit lip on bearing into recess in cylinder block (fig. 67). NOTE: Bearings Nos. 1, 2, and 3, both upper and lower, are interchangeable. Press bearings firmly into opening in block. Be sure that oilhole in bearing aligns with oilhole in block (fig. 69). Use an oilcan to

ORDNANCE MAINTENANCE — POWER UNIT FOR  
MEDIUM TANKS M3A4 AND M4A4

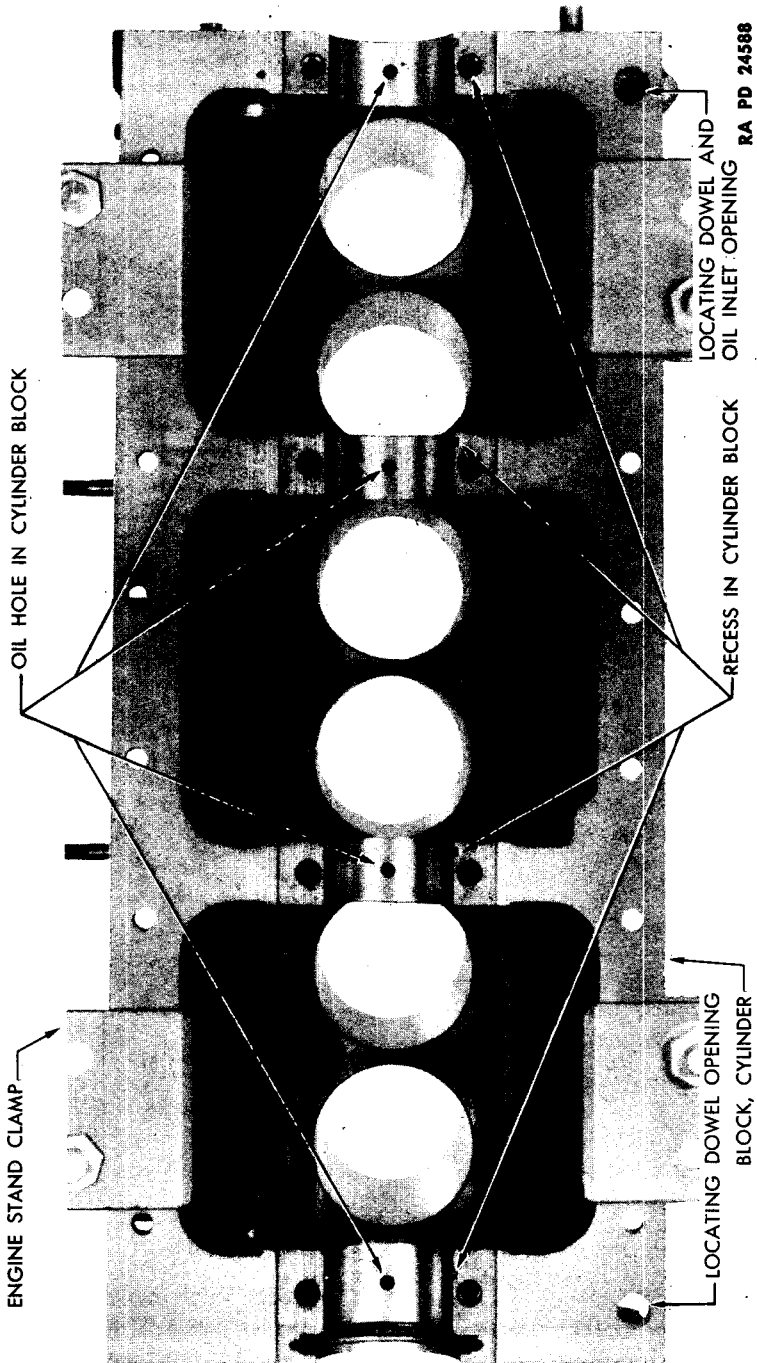
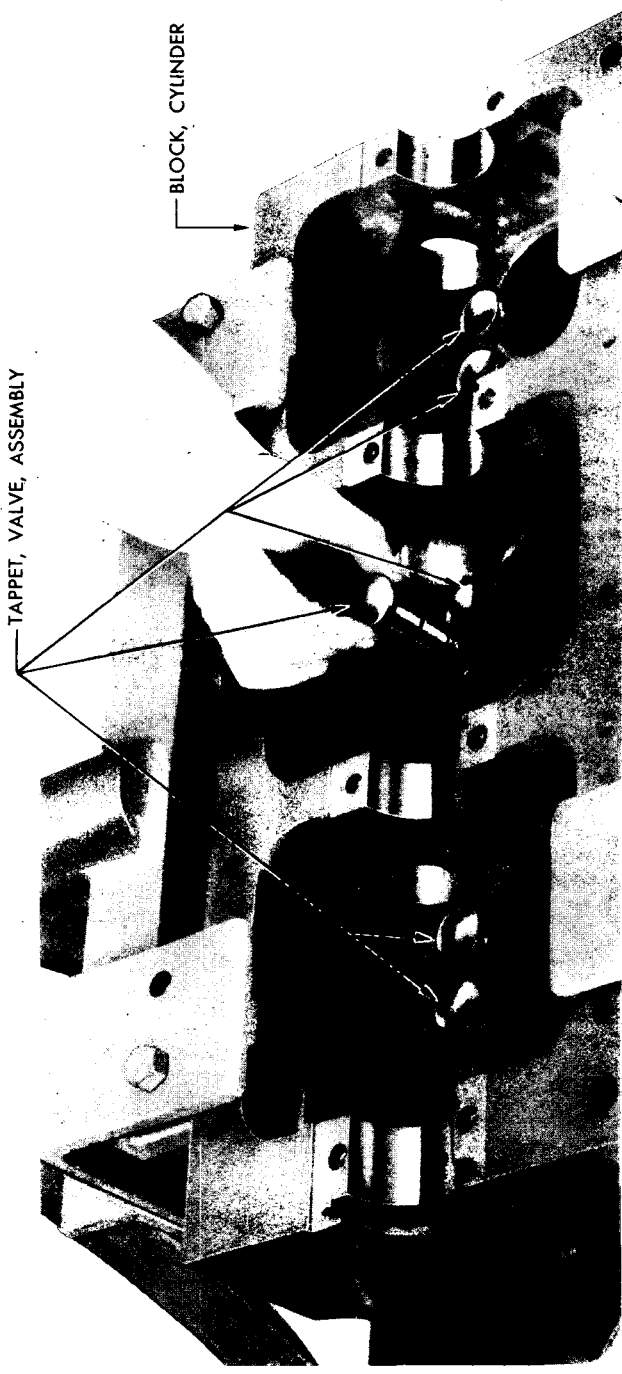


Figure 67 — Cylinder Block, Showing Oilholes

ASSEMBLY OF INDIVIDUAL ENGINE



RA PD 24590

Figure 68 — Installing Valve Tappets



ORDNANCE MAINTENANCE — POWER UNIT FOR  
MEDIUM TANKS M3A4 AND M4A4

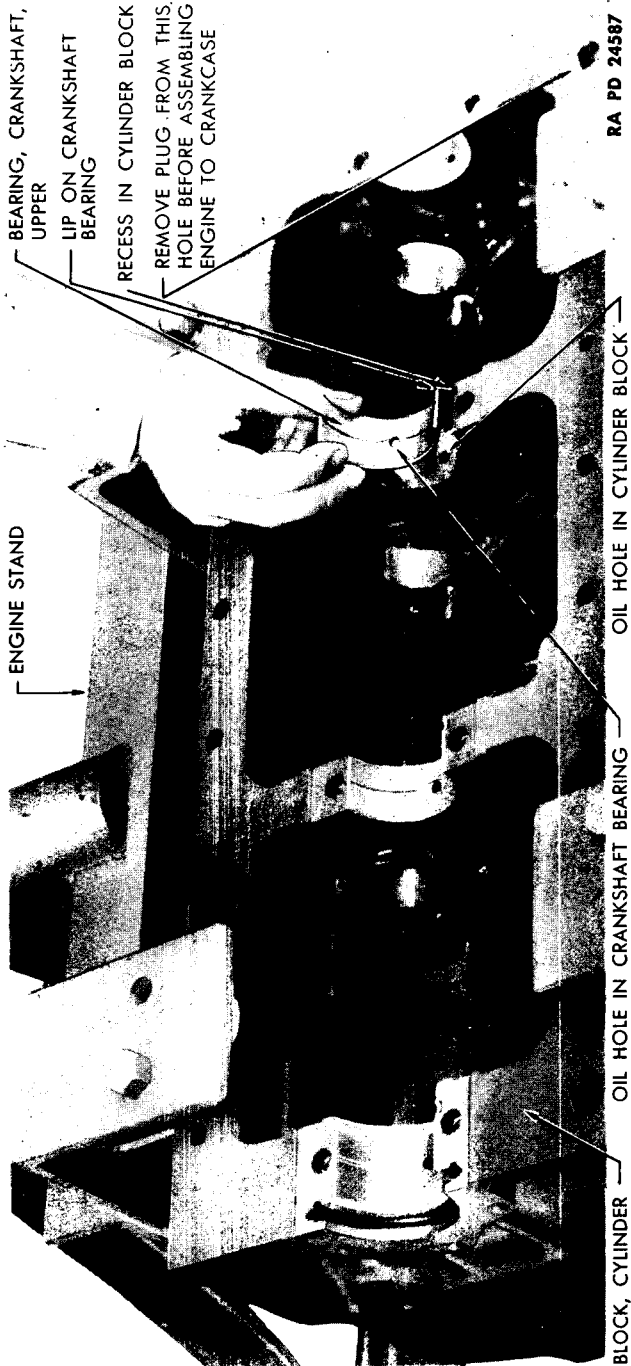
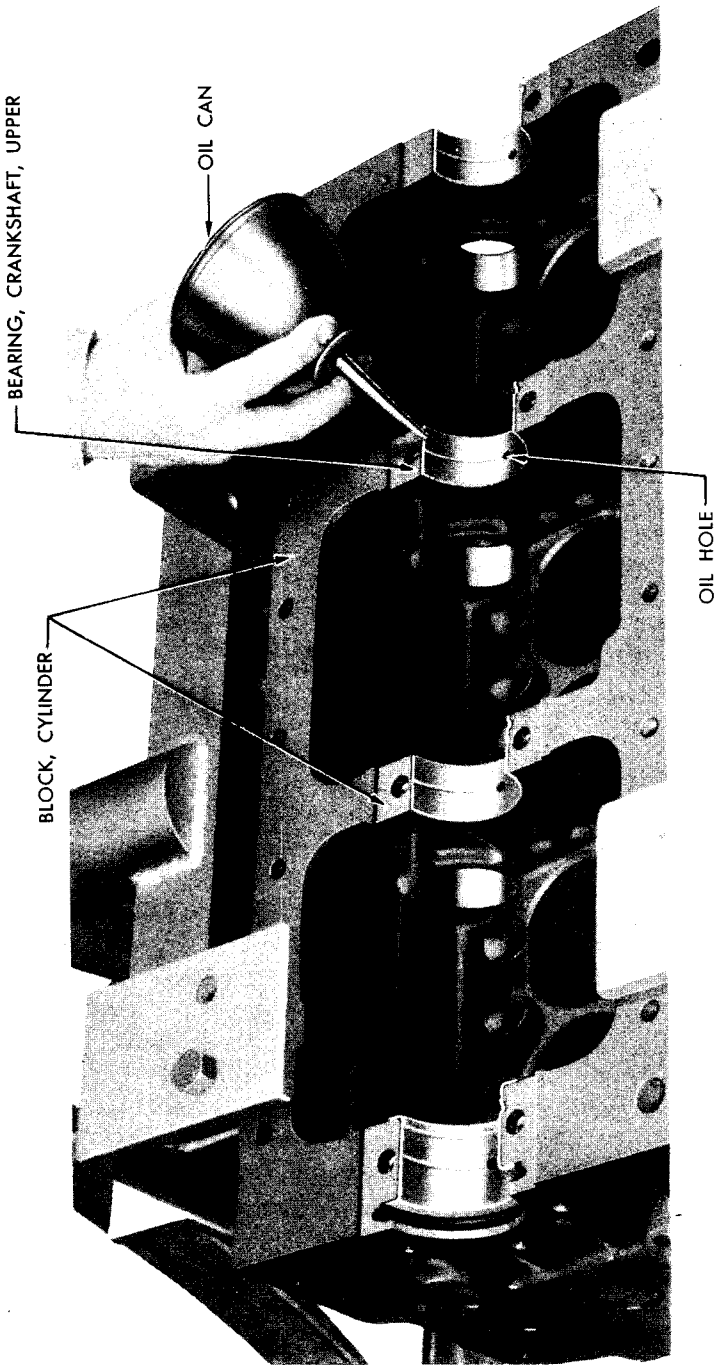


Figure 69 — Installing Crankshaft Bearing

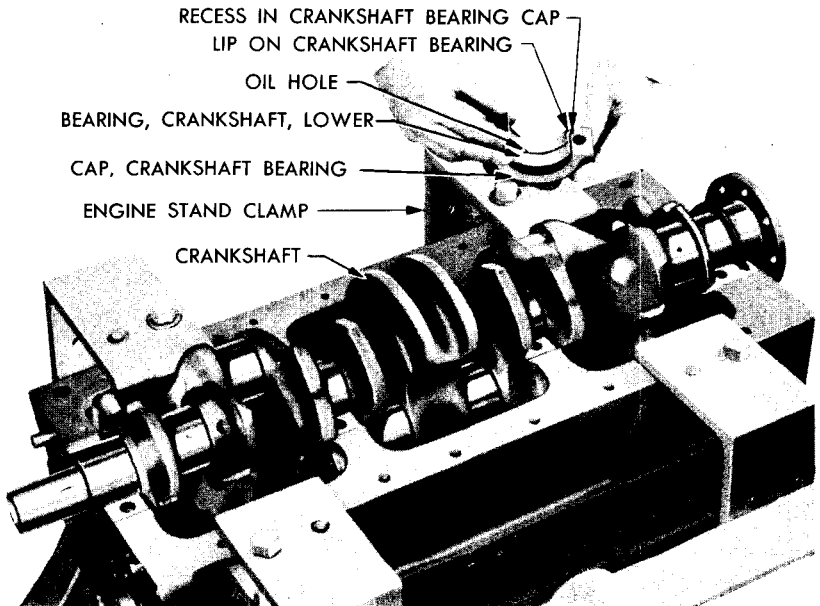
ASSEMBLY OF INDIVIDUAL ENGINE



RA PD 24589

Figure 70 — Oiling Crankshaft Bearings

## ORDNANCE MAINTENANCE – POWER UNIT FOR MEDIUM TANKS M3A4 AND M4A4



RA PD 24680

**Figure 71 – Installing Crankshaft Bearing In Cap**

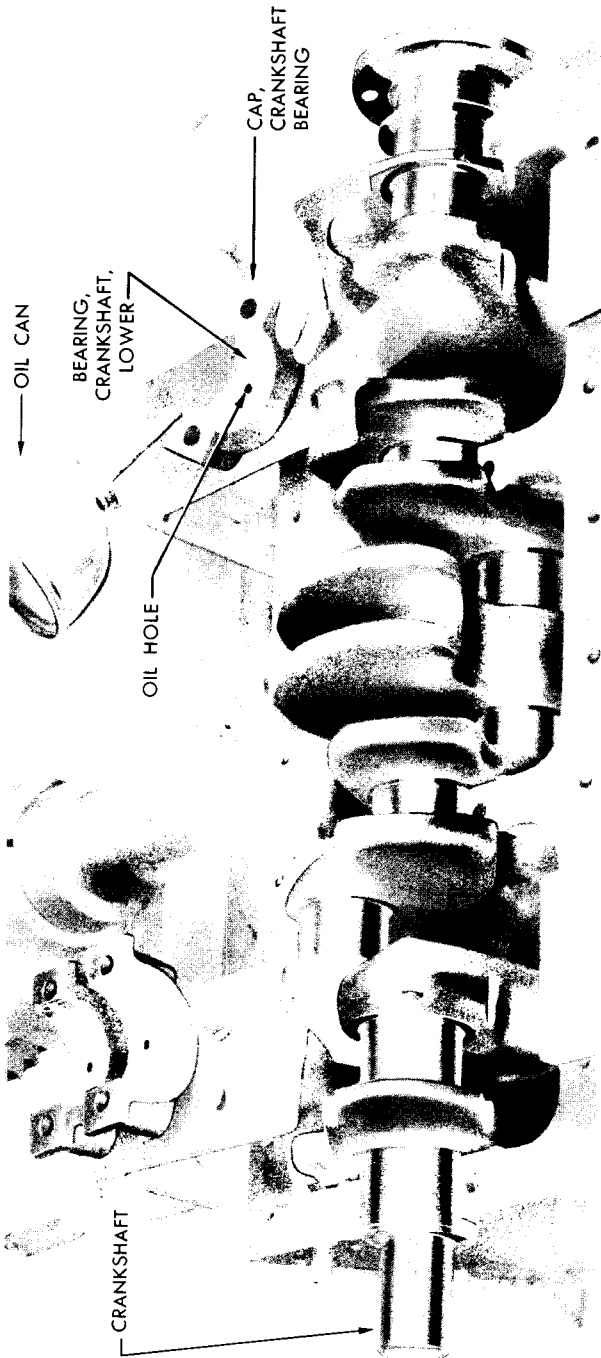
oil surface of bearing thoroughly (fig. 70). Lay crankshaft in bearings in cylinder block. Be sure that all journals are free from burs, to avoid damage to bearings. Fit bearing in cap, being sure that lip on bearing is fitted into recess in cap (fig. 71). Using an oilcan, oil surface of bearing thoroughly (fig. 72). Install cap on cylinder block according to prick punch marks established when disassembling the engine (fig. 73). Using new lock washers on cap screws, insert crankshaft bearing cap screws through cap and screw into block with fingers. Tap cap lightly, with rawhide hammer to be sure cap is resting on cylinder block (fig. 74). Tighten cap screws to 75 to 80 foot pounds with 1-inch socket wrench and torque wrench (fig. 75). Check the crankshaft end play by placing a pinch bar between the No. 4 bearing cap and end crank throw of crankshaft and forcing shaft toward opposite end of engine. Hold shaft in this position and measure clearance with a feeler gage (fig. 76). The permissible end play is 0.003 to 0.007 inch, with the minimum figure desired.

(2) **INSTALL CYLINDER HEAD STUDS AND EXHAUST MANIFOLD STUDS** (figs. 77 and 78).

**DRIVER and REMOVER, stud**                      **HAMMER, brass**

Place cylinder head dowels in position and tapping lightly, with brass hammer, drive into place in cylinder block (fig. 16). Paint coarse threads

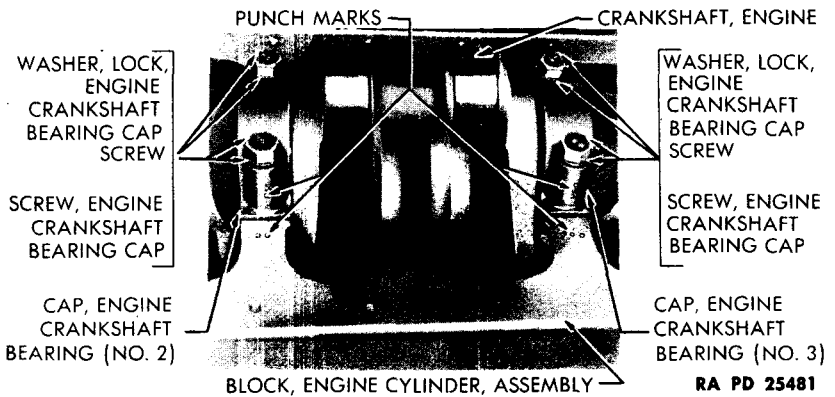
ASSEMBLY OF INDIVIDUAL ENGINE



RA PD 24591

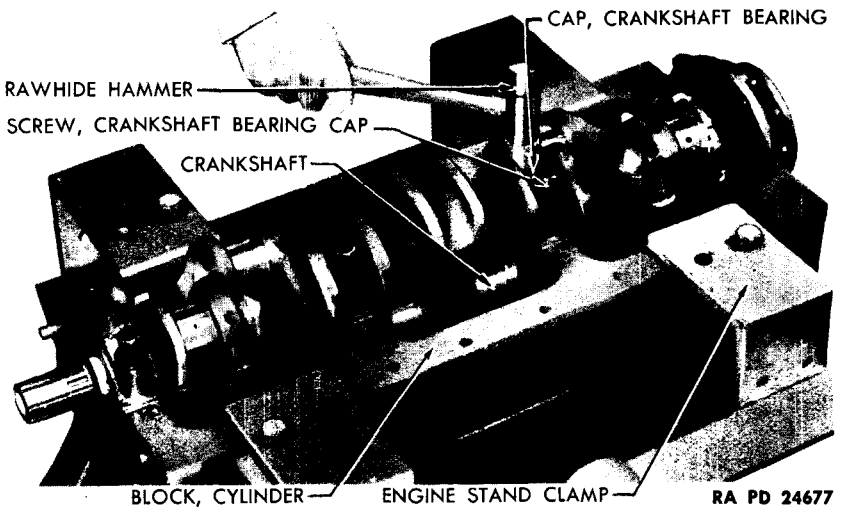
Figure 72 — Oiling Crankshaft Bearing Cap

ORDNANCE MAINTENANCE – POWER UNIT FOR  
MEDIUM TANKS M3A4 AND M4A4



**Figure 73 – Prick Punch Marks To Locate Crankshaft Bearing Caps**

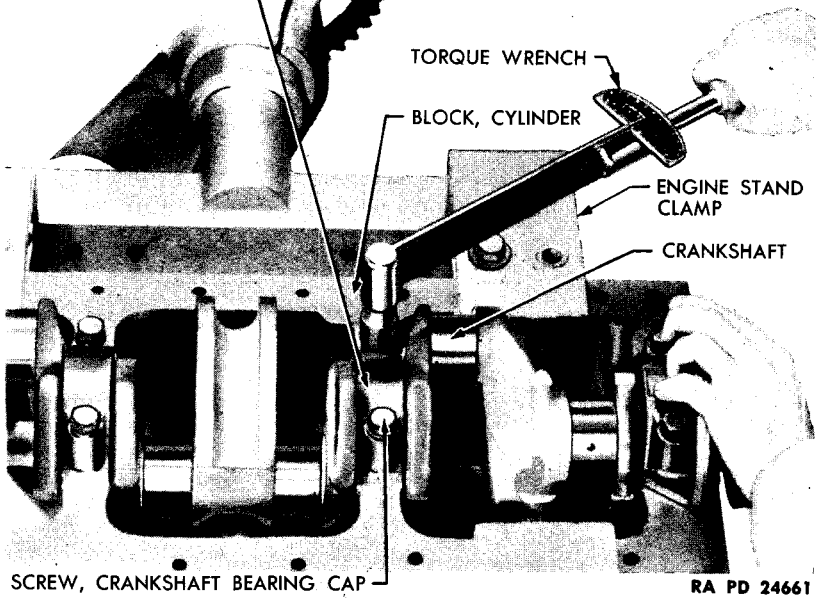
with Neoprene latex cement and, with a stud driver, screw cylinder head studs into top of cylinder block and exhaust manifold studs into side of cylinder block according to outline of locations. **NOTE:** In view of the fact that studs of various lengths are used, it is necessary to install studs as shown in figure 77 for the Model M3A4 and figure 78 for Model M4A4.



**Figure 74 – Tapping Bearing Cap In Position**

**ASSEMBLY OF INDIVIDUAL ENGINE**

CAP, CRANKSHAFT BEARING



RA PD 24661

**Figure 75 – Tightening Crankshaft Bearing Cap Screws**

**(3) INSTALL CAMSHAFT.**

**DRIFT**

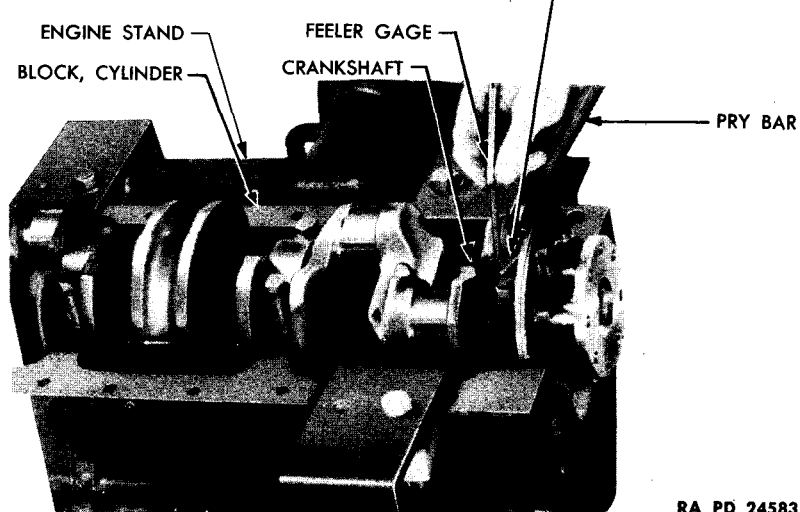
**HAMMER, 1-lb.**

**PRESS**

**WRENCH, 1/2-in.**

Place camshaft gear hub thrust plate on end of camshaft, insert key in keyway in shaft and press camshaft gear hub on shaft, with shoulder on

CAP, CRANKSHAFT BEARING, No. 4

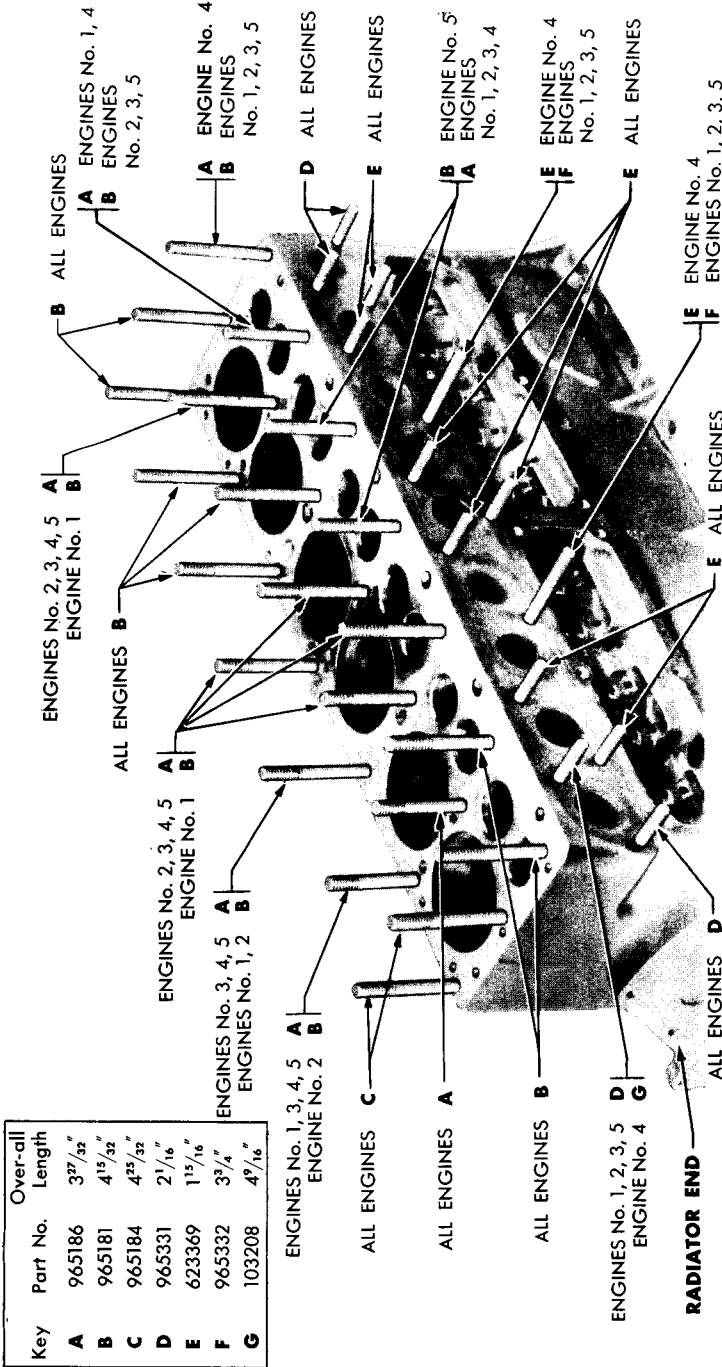


RA PD 24583

**Figure 76 – Checking Crankshaft End Play**



ASSEMBLY OF INDIVIDUAL ENGINE

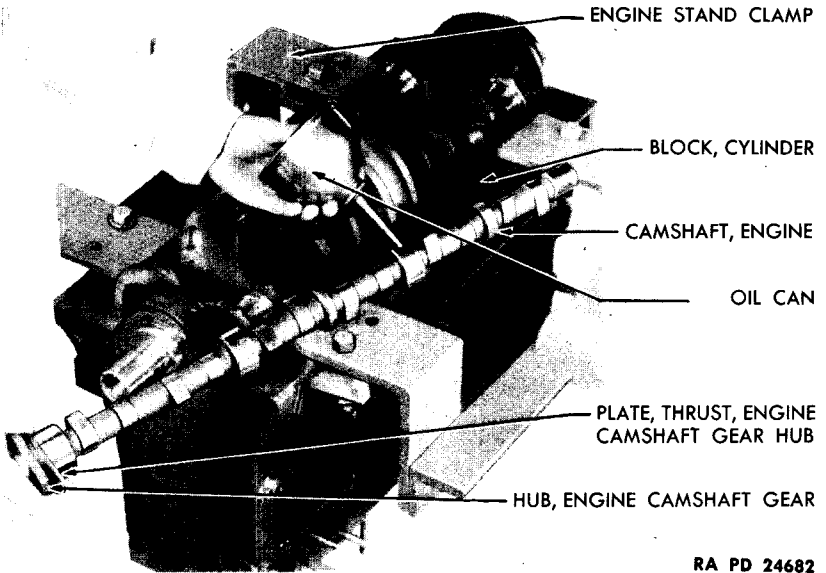


RA PD 25599

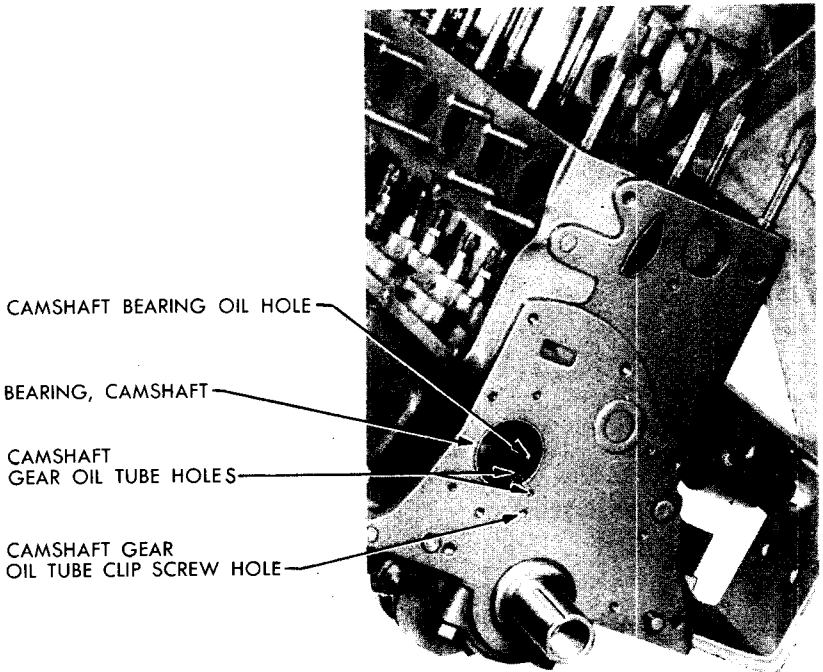
Figure 78 — Cylinder Head Stud And Manifold Stud Locations (M4A4)



**ORDNANCE MAINTENANCE – POWER UNIT FOR  
MEDIUM TANKS M3A4 AND M4A4**

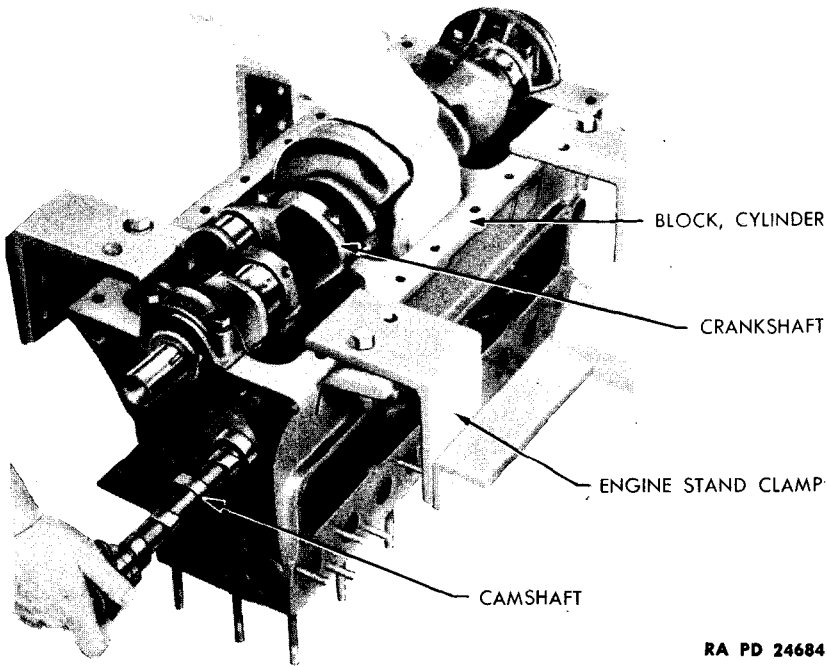


**Figure 79 – Oiling Camshaft Bearing Journal**



**Figure 80 – Distributor End Of Cylinder Block, Showing Oilholes**

## ASSEMBLY OF INDIVIDUAL ENGINE



RA PD 24684

**Figure 81 – Installing Camshaft**

hub away from shaft. Check clearance between thrust plate and hub and adjust position of hub on shaft to provide 0.002- to 0.006-inch clearance (fig. 79). Check camshaft bearing oilhole and camshaft gear oil tube holes (one in bearing, connecting to one in end of cylinder block) (fig. 80) to be sure holes are free from obstructions. Oil the camshaft bearings (fig. 79). Insert shaft in opening in end of cylinder block, steady opposite end of shaft with one hand and rotate shaft while assembling in block, to prevent interference (fig. 81). Be very careful not to damage shaft while installing. Using new camshaft gear hub thrust plate screw locks, install the 2 attaching screws and tighten securely ( $\frac{1}{2}$ -in. wrench). Bend tabs of screw locks to secure screws in place (fig. 82) (hammer and drift). Install camshaft gear hub snap ring in groove in end of camshaft (fig. 83).

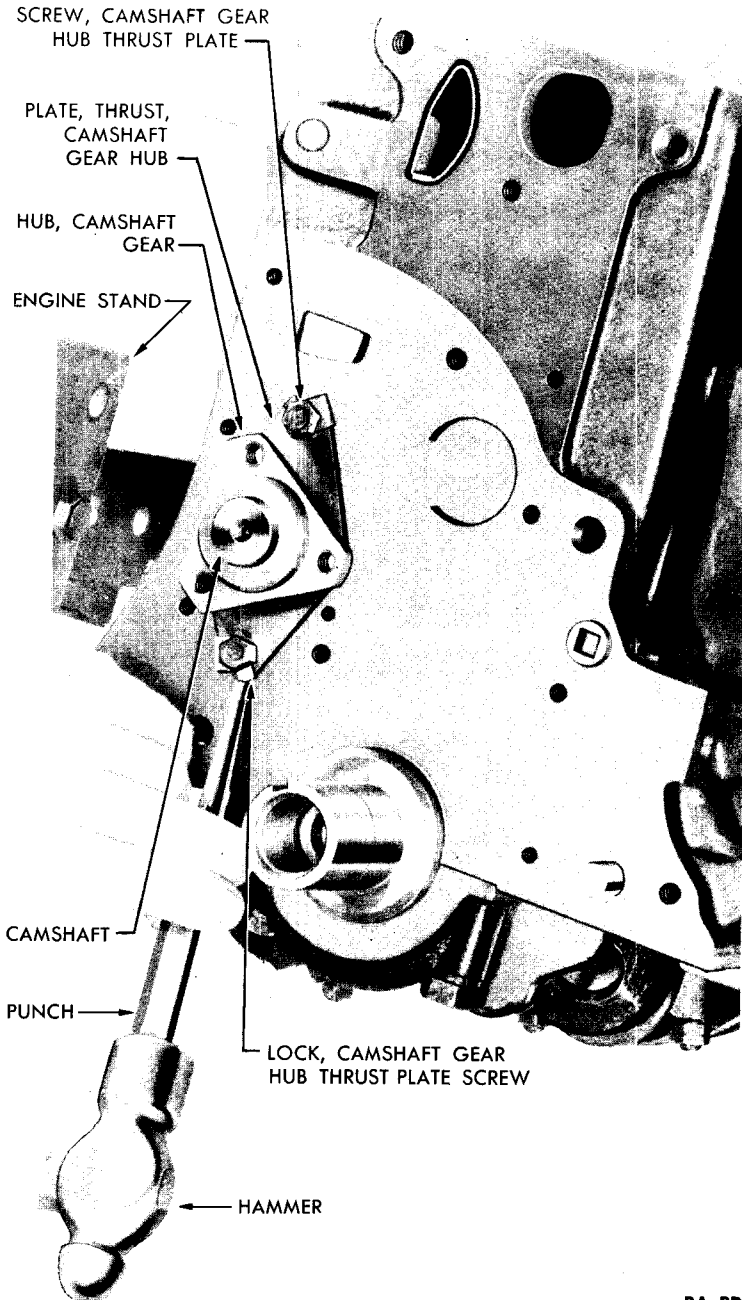
**(4) INSTALL PISTONS AND CONNECTING RODS.**

SLEEVE, piston installing  
WRENCH, socket,  $\frac{9}{8}$ -in.

WRENCH, torque

Install connecting rod bearings in rod end cap matching lip on bearing with recess in rod and cap (fig. 84). Press bearings firmly into openings. Be sure oilhole in bearing matches hole in connecting rod. Using oilcan, oil connecting rod bearing (fig. 85), piston pin (fig. 86), piston and rings

ORDNANCE MAINTENANCE — POWER UNIT FOR  
MEDIUM TANKS M3A4 AND M4A4



RA PD 25325

Figure 82 — Bending Tabs On Camshaft Thrust Plate Lock Screw

ASSEMBLY OF INDIVIDUAL ENGINE

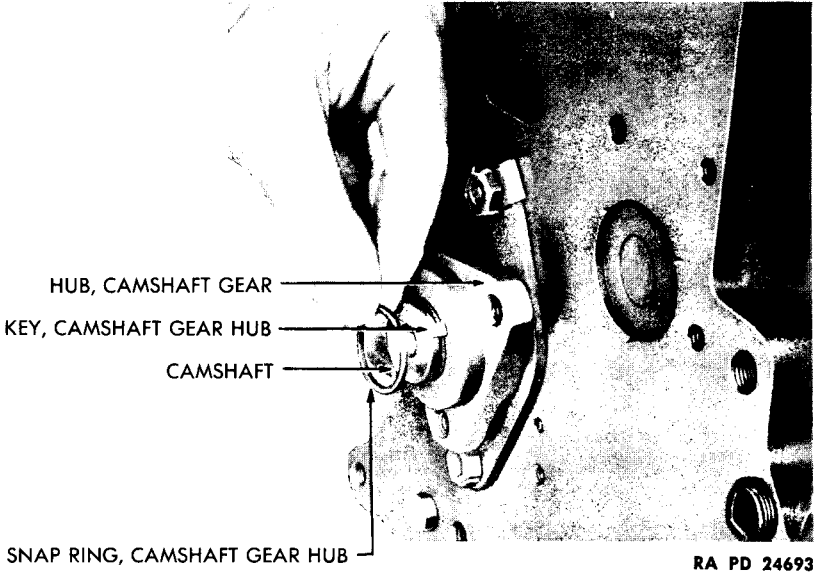


Figure 83 – Installing Snap Ring

(fig. 87). **CAUTION:** The oilhole in connecting rod bearing (fig. 89) aligns with a metered hole in connecting rod, to lubricate piston pin. Install connecting rod so this metered hole is opposite the camshaft when installed in the engine. Position rings on piston so gaps of the 4 rings are

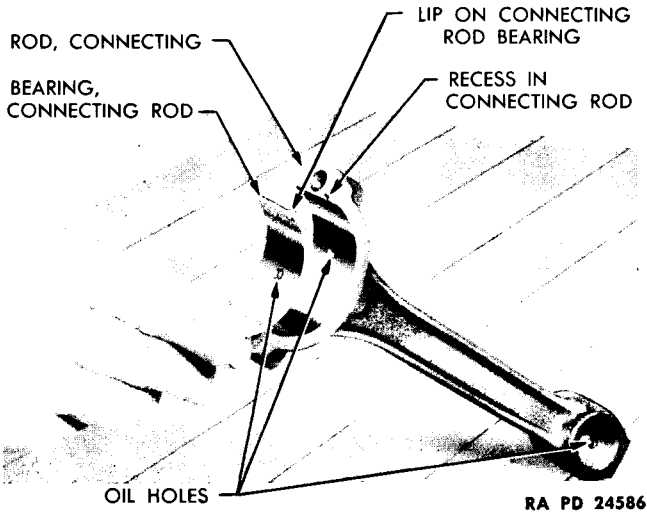
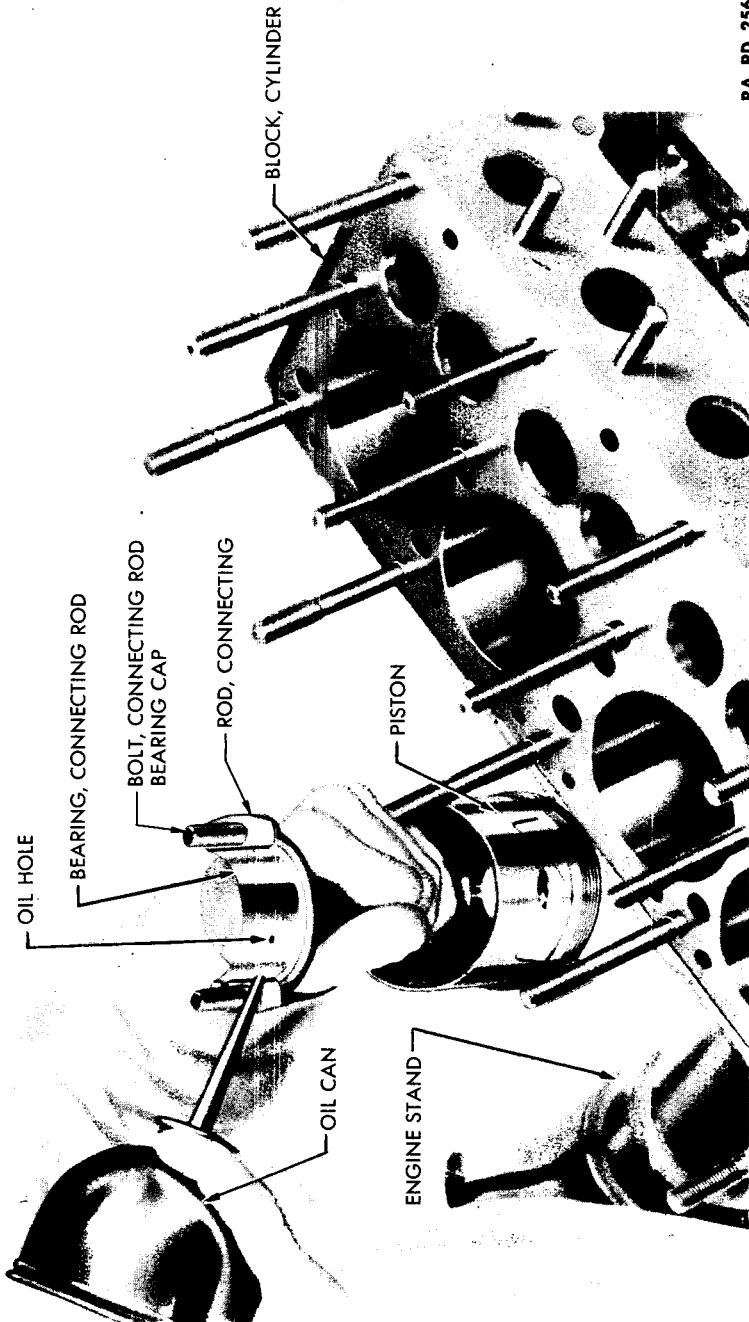


Figure 84 – Connecting Rod And Bearing

ORDNANCE MAINTENANCE — POWER UNIT FOR  
MEDIUM TANKS M3A4 AND M4A4



RA PD 25604

Figure 85 — Oiling Connecting Rod Bearing

## ASSEMBLY OF INDIVIDUAL ENGINE

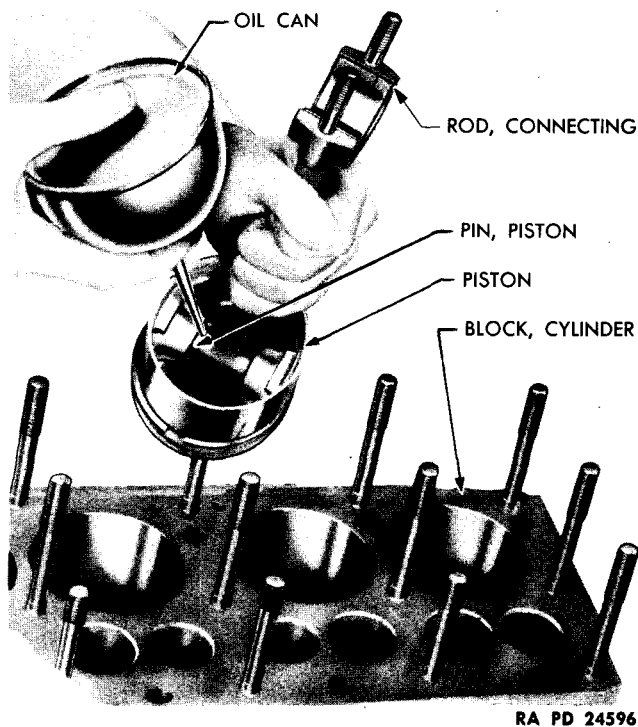


Figure 86 — Oiling Piston Pin

staggered, to prevent compression blow by through gaps (fig. 88). Insert piston and rings into installing sleeve (fig. 90) until rings are compressed into grooves in piston. Insert connecting rod into top of cylinder, as indicated by identification numbers (fig. 91) and force piston out of sleeve, and into cylinder (fig. 92). Secure connecting rod to crankshaft with 2 cap bolts, nuts, and new lock washers. Tighten nuts to 45 to 50 foot pounds with  $\frac{9}{16}$ -inch socket wrench and torque wrench (fig. 93). Repeat operations to install the other 5 connecting rods and pistons.

(5) INSTALL VALVES.

LIFTER, valve

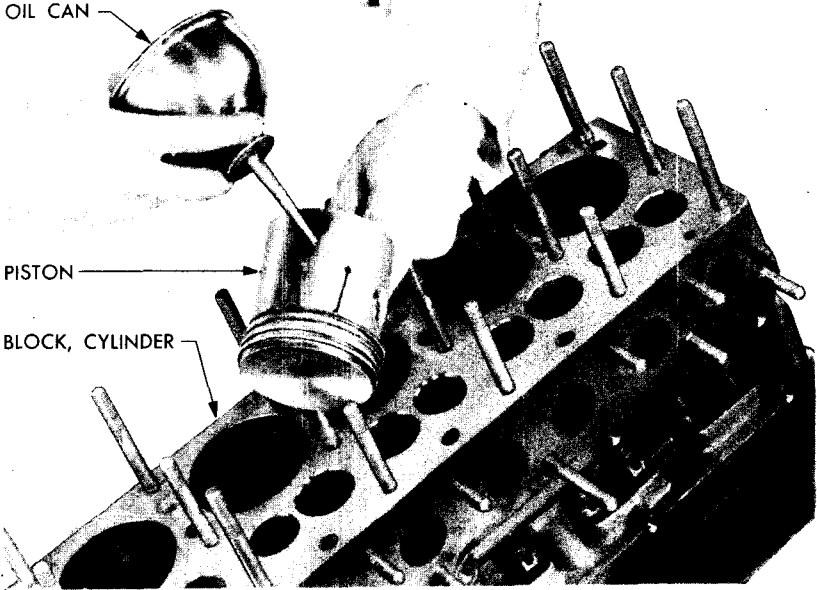
OILCAN

WRENCH, tappet,  $\frac{7}{16}$ -in.

WRENCH, tappet,  $\frac{1}{2}$ -in.

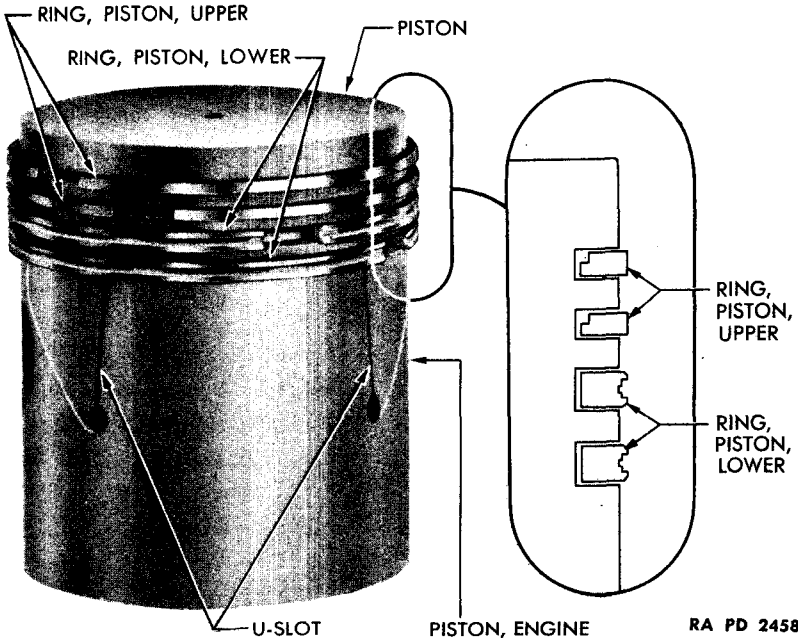
NOTE: When installing valve springs in cylinder block, be sure to install spring with close coils at top (fig. 94). Place valve spring retainer on end of spring and, with camshaft located so as to permit valve tappet assembly to drop to its lower position, assemble spring and retainer in block as shown in figure 94. NOTE: Be sure the upper end of spring fits in recess shown in figure 94. Oil stem of valve and install in its original location in cylinder block, as indicated by its relative position in board in

ORDNANCE MAINTENANCE – POWER UNIT FOR  
MEDIUM TANKS M3A4 AND M4A4



RA PD 24681

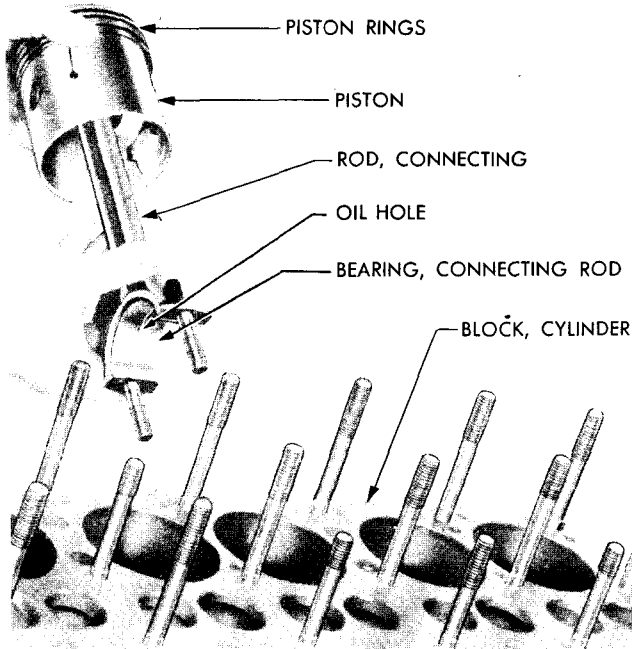
Figure 87 – Oiling Piston And Rings



RA PD 24584

Figure 88 – Piston And Rings, Showing Ring Gap Locations

**ASSEMBLY OF INDIVIDUAL ENGINE**



RA PD 24595

**Figure 89 — Showing Proper Position Of Connecting Rod In Cylinder**

which it was placed when removed from cylinder block. Raise valve retainer with valve lifter, compressing spring at same time forcing lower end of valve stem through hole in retainer, a sufficient distance to permit installation of the 2 valve spring retainer locks on lower end of valve stem. **NOTE:** Be sure that projections on inside of locks seat firmly into grooves on lower end of valve stem. Repeat operation to install the other 11 valves, being sure that tappet is at its lower position before attempting to install valve and spring. Adjust clearance between valve tappet screw and lower end of valve stem by rotating camshaft until the valve tappet is at its lower position, place  $\frac{1}{2}$ -inch tappet wrench on upper end of valve tappet and  $\frac{7}{8}$ -inch tappet wrench on valve tappet screw. Adjust screw until proper clearance is obtained (0.010-inch intake valve, 0.014-inch exhaust valve, measured when cold) (fig. 95). **NOTE:** Tappets are of the self-locking type. Repeat operation to adjust the other 11 tappets, being sure that tappet is at its lowest position before attempting to adjust.

**(6) INSTALL CYLINDER HEAD.**

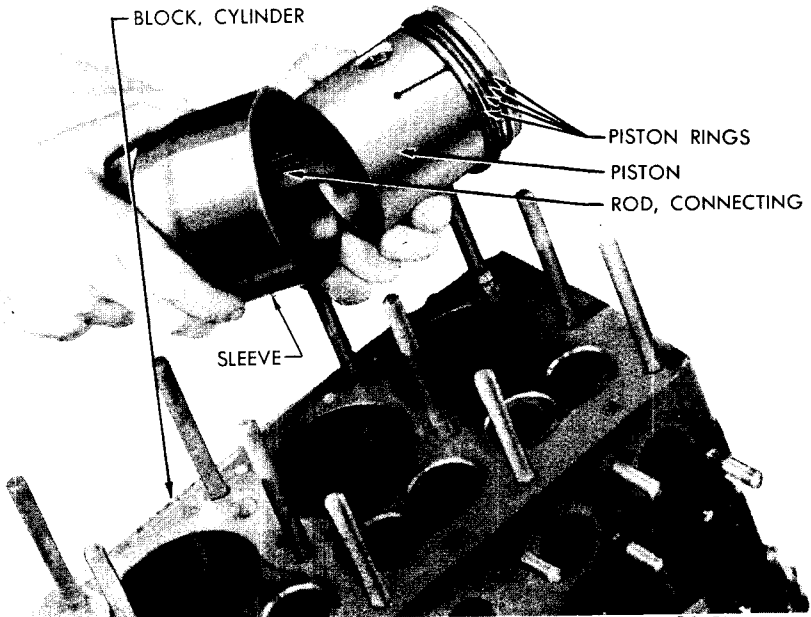
**DRIVER and REMOVER,**  
stud

**WRENCH,** socket,  $\frac{1}{8}$ -in.  
**WRENCH,** torque

Wipe off top of cylinder head and pistons and oil inside of cylinder bores and around heads of valves. Place new cylinder head gasket (care-



**ORDNANCE MAINTENANCE — POWER UNIT FOR  
MEDIUM TANKS M3A4 AND M4A4**



RA PD 24678

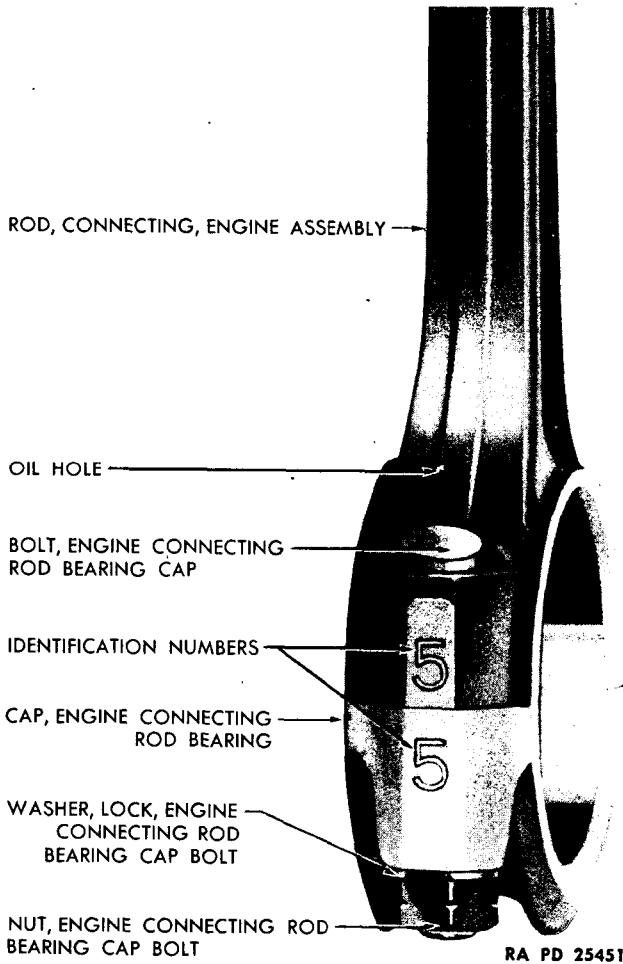
**Figure 90 — Installing Sleeve On Piston**

fully so as not to damage gasket) over studs and dowels, until gasket rests on cylinder block (fig. 96). Wipe mounting face of cylinder head and mount head on block. Install nuts on cylinder head studs (all except the 3 end studs at radiator end of cylinder block). Paint coarse threads of cylinder head adapter stud (five in all), and screw into top of cylinder head, at radiator end (stud driver) (fig. 97). Install thermostat in opening in cylinder head (used in all 5 engines in power units up to and including serial No. 3211. Used in No. 1 engine only after serial No. 3211) with flange of thermostat resting on casting. Position new thermostat gasket (rubber) on top of thermostat. Position new gasket on cylinder head and install adapter over studs. Install nuts and lock washers on adapter studs and nuts on the cylinder head studs. Tighten cylinder head stud nuts, with  $\frac{1}{8}$ -inch socket wrench and torque wrench (fig. 98), *in the sequence shown in figure 99*, to 60 to 65 foot pounds. Tighten adapter stud nuts to 25 to 30 foot pounds. **CAUTION:** Install plugs in spark plug holes, to exclude dirt. Screw timing hole plug in opening at distributor end of cylinder head.

**(7) INSTALL CRANKSHAFT OIL SEAL PLATE.  
SCREWDRIVER**

Position plate on cylinder block, as shown in figure 100 and secure with 2 screws and lock washers. **NOTE:** Be sure that Neoprene oil seals are in position in the seal plate.

**ASSEMBLY OF INDIVIDUAL ENGINE**



**Figure 91 — Connecting Rod Identification Numbers**

**(8) INSTALL CRANKSHAFT GEAR.**

**TOOL**, installing, crankshaft gear

Install crankshaft gear key in crankshaft (fig. 101), place gear on crankshaft (with timing zero on gear away from cylinder block and press shaft with installing tool, as shown in figure 102, until gear rests against shoulder on shaft):

**(9) INSTALL GEAR CASE COVER PLATE.**

**HAMMER**, 1-lb.

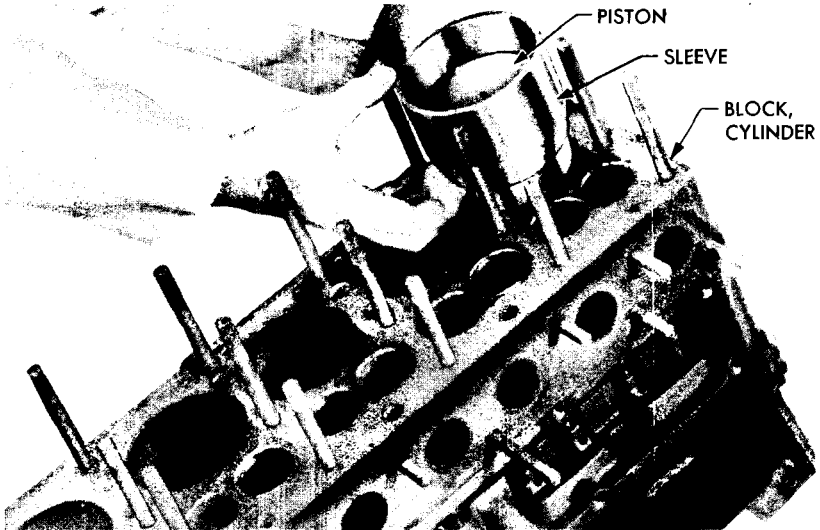
**PUNCH**, prick

**SCREWDRIVER**

**WRENCH**, 1/2-in.

**WRENCH**, torque

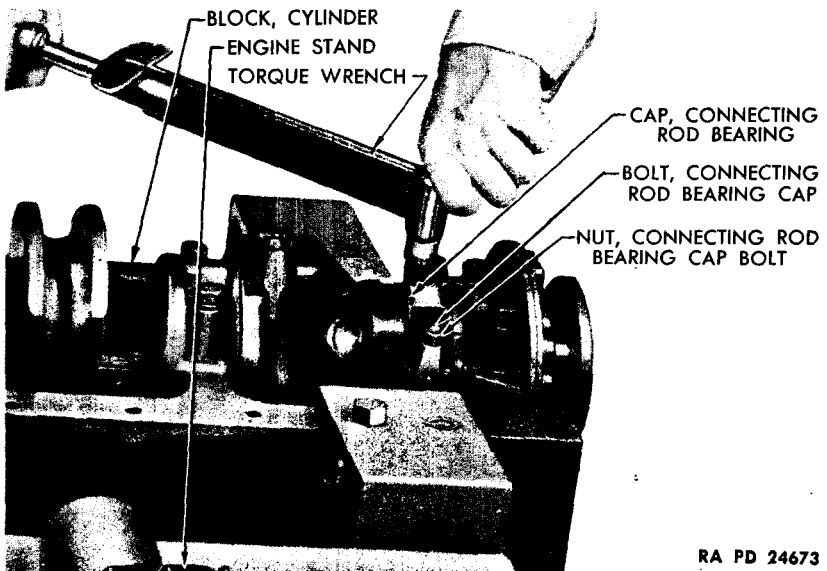
**ORDNANCE MAINTENANCE – POWER UNIT FOR  
MEDIUM TANKS M3A4 AND M4A4**



RA PD 24679

**Figure 92 – Installing Connecting Rod And Piston In Cylinder**

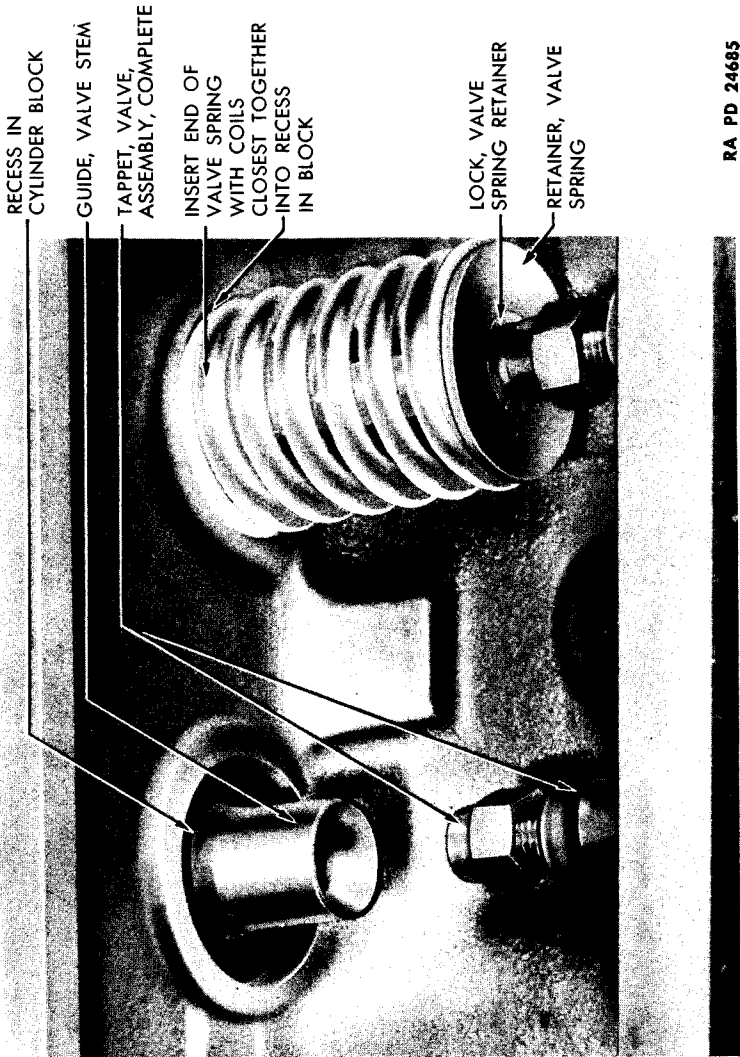
Place new gasket on end of cylinder block (fig. 103) and install plate over 2 dowels. Secure plate with 4 cap screws and lock washers (1/2-in. wrench). Tighten to 12 to 17 foot pounds (torque wrench). Install gear



RA PD 24673

**Figure 93 – Tightening Connecting Rod Cap Bolts**

ASSEMBLY OF INDIVIDUAL ENGINE



RA PD 24685

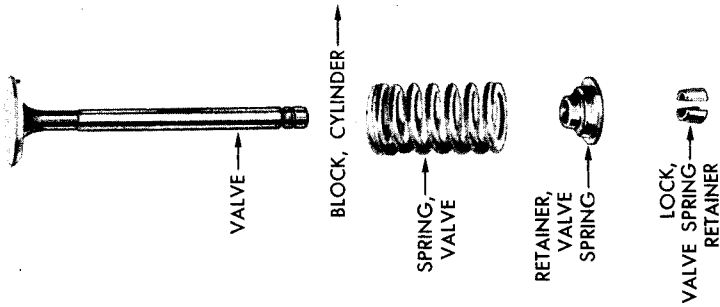


Figure 94 — Correct Installation Of Valve Spring, Retainer And Locks

ORDNANCE MAINTENANCE — POWER UNIT FOR  
MEDIUM TANKS M3A4 AND M4A4

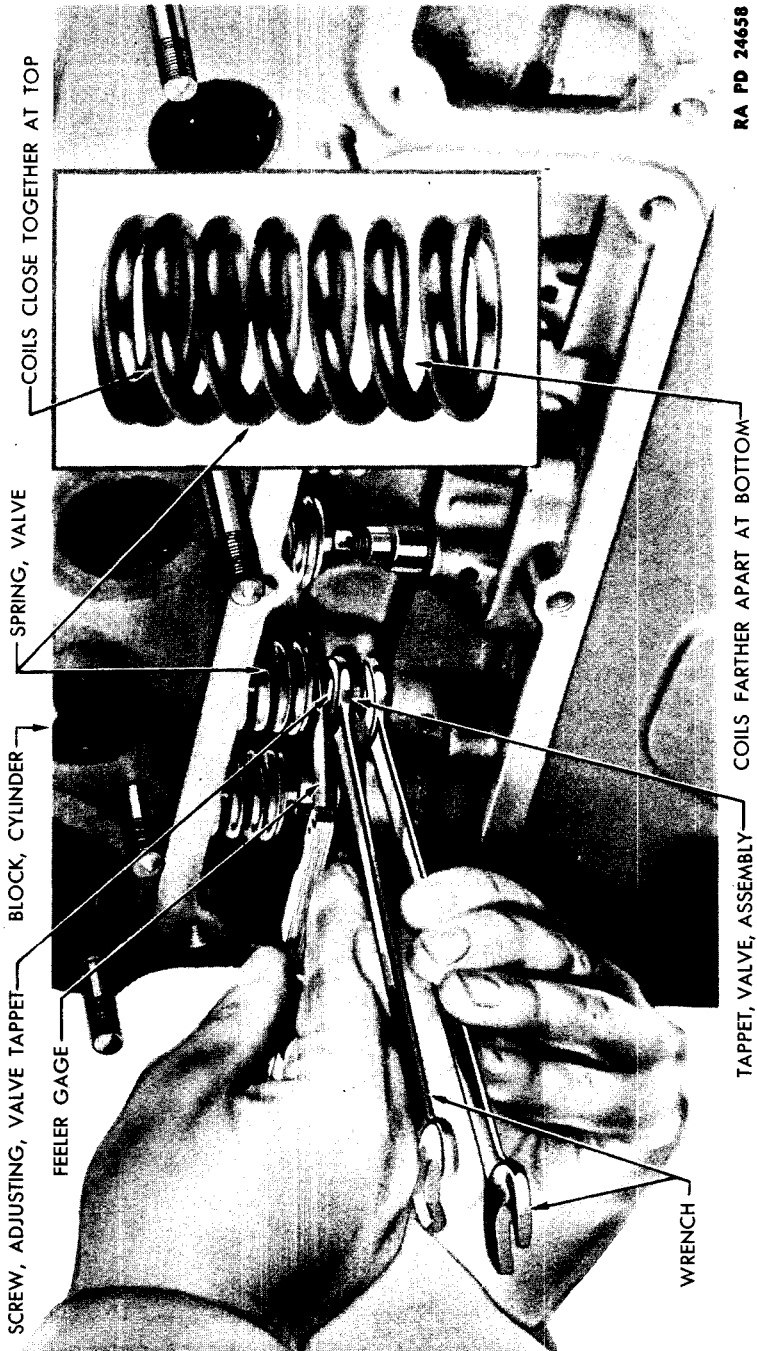
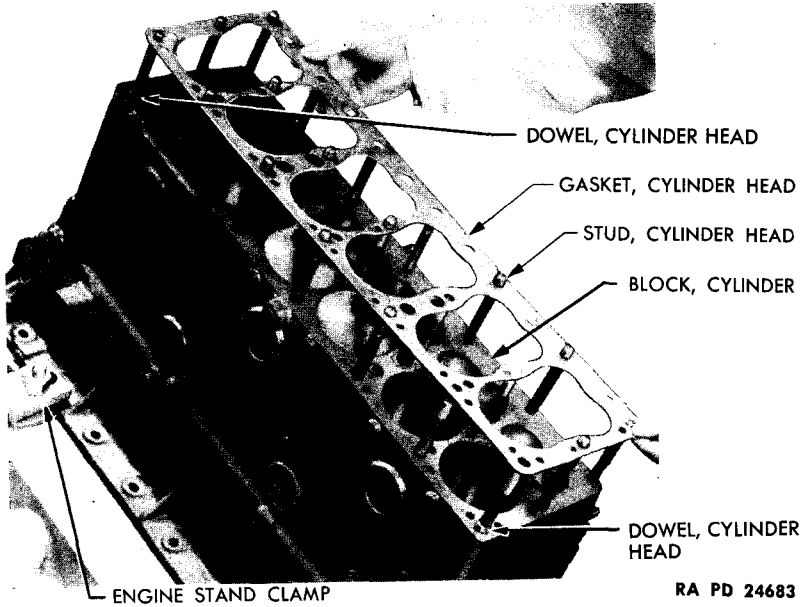


Figure 95 — Adjusting Valve Tappets

ASSEMBLY OF INDIVIDUAL ENGINE



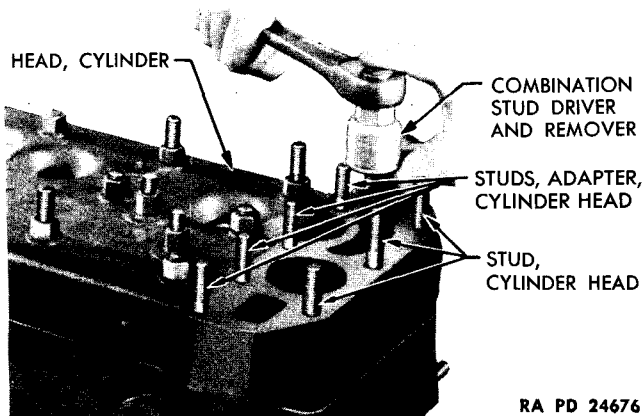
**Figure 96 – Installing Cylinder Head Gasket**

case cover plate countersunk screw with screwdriver and stake screw in place with hammer and prick punch (fig. 104).

(10) INSTALL CAMSHAFT GEAR OIL TUBE (fig. 105).

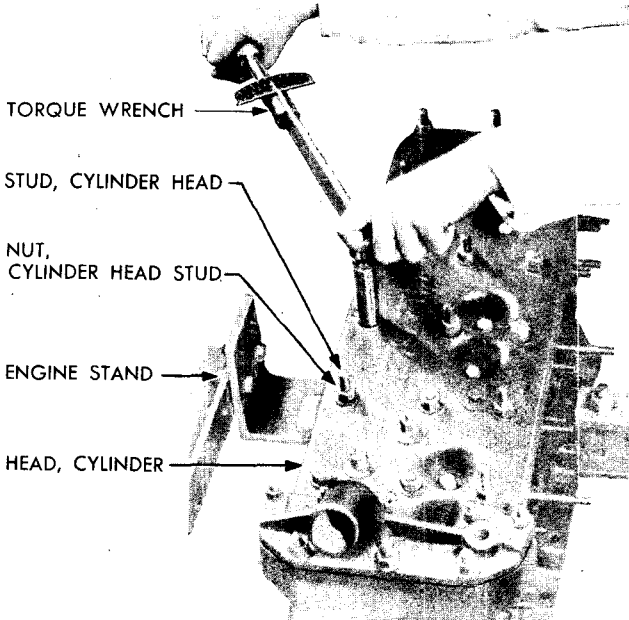
WRENCH, 1/2-in.

Insert end of tube into oilhole in cylinder block and secure with clip, lock washer, and cap screw.



**Figure 97 – Removing Or Installing Cylinder Head Adapter Studs**

**ORDNANCE MAINTENANCE – POWER UNIT FOR  
MEDIUM TANKS M3A4 AND M4A4**



RA PD 24662

**Figure 98 – Tightening Cylinder Head Stud Nuts**

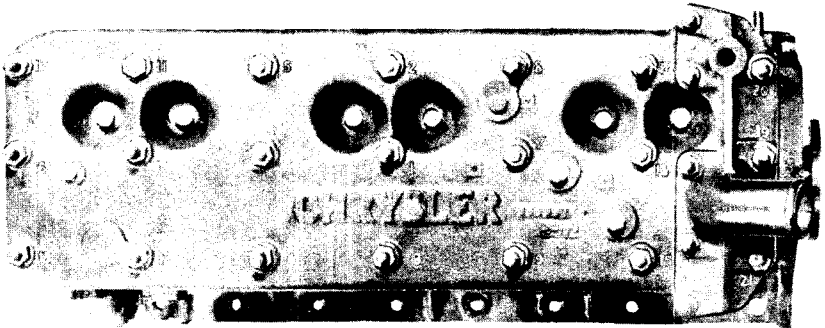
**(11) INSTALL CAMSHAFT GEAR AND DISTRIBUTOR DRIVE GEAR.**

**HAMMER**

**WRENCH, socket, 3/4-in.**

**PUNCH, prick**

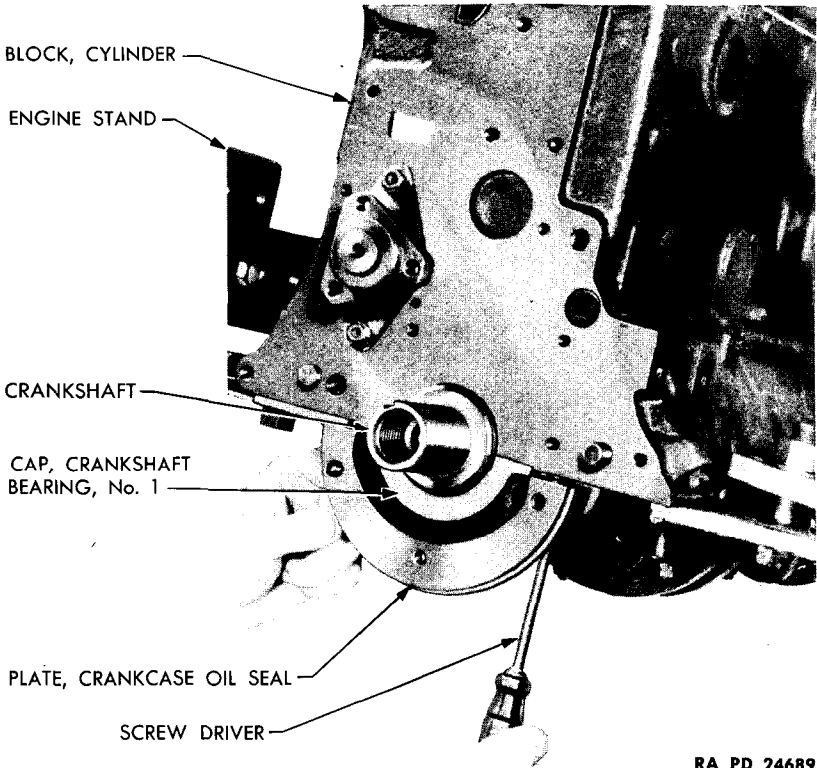
Rotate crankshaft until timing zero on gear is toward camshaft. Rotate camshaft until camshaft gear can be mounted on camshaft gear hub, and secured to hub with indexing zeros on both crankshaft gear and camshaft gear alined (fig. 106). Install distributor drive gear on camshaft gear,



RA PD 24660

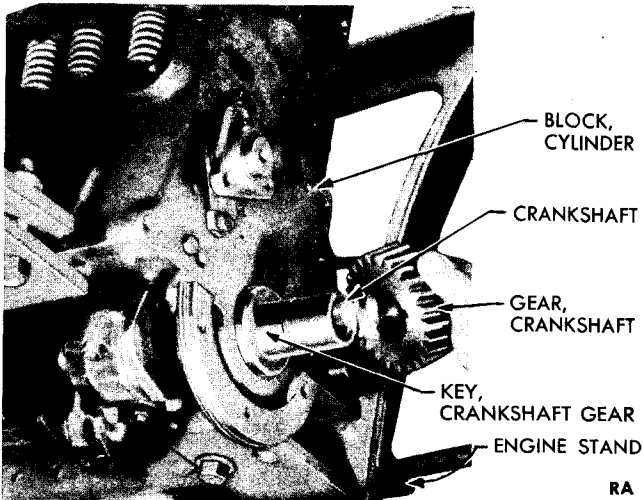
**Figure 99 – Sequence For Tightening Cylinder Head Stud Nuts**

ASSEMBLY OF INDIVIDUAL ENGINE



RA PD 24689

**Figure 100 – Installing Crankshaft Oil Seal Plate**

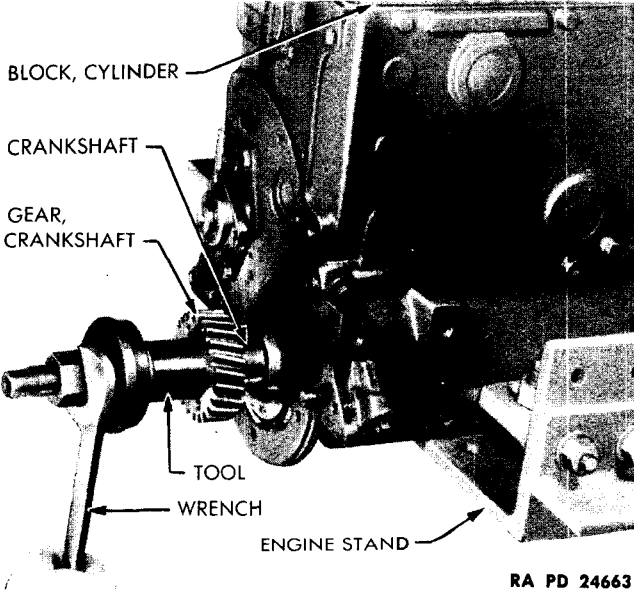


RA PD 24667

**Figure 101 – Crankshaft Gear And Key In Position For Installing Gear**

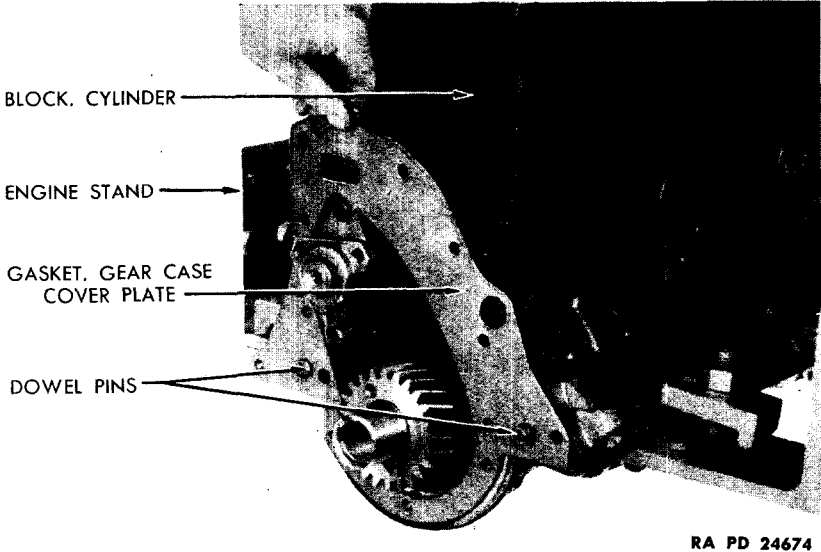


ORDNANCE MAINTENANCE — POWER UNIT FOR  
MEDIUM TANKS M3A4 AND M4A4



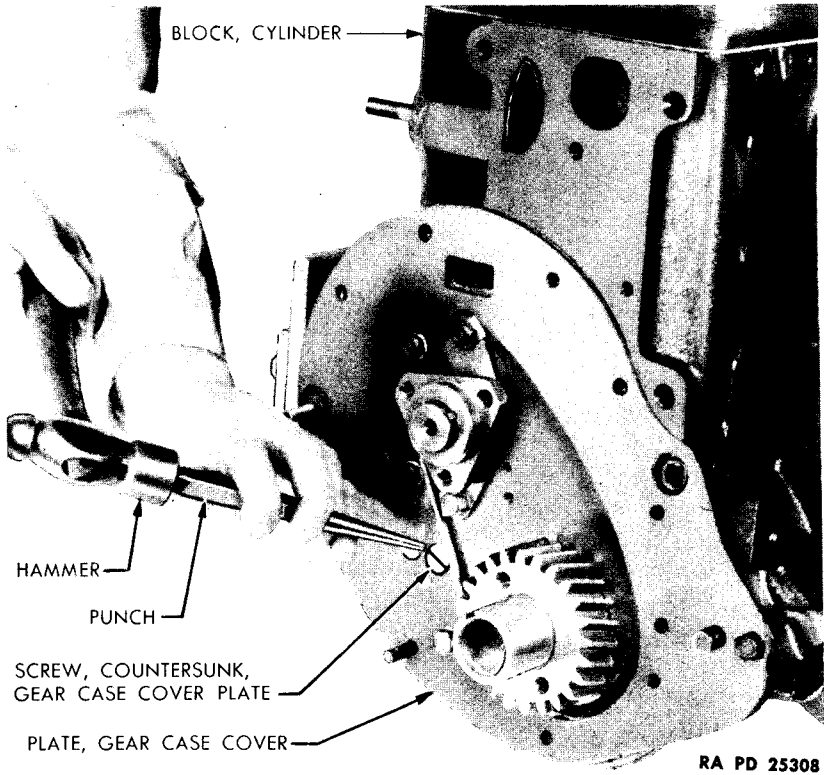
**Figure 102 — Installing Crankshaft Gear**

install lock washer and secure with 3 cap screws. Tighten screws with  $\frac{3}{4}$ -inch socket wrench and bend tabs of lock washer to secure the 3 cap screws (hammer and prick punch) (fig. 107).

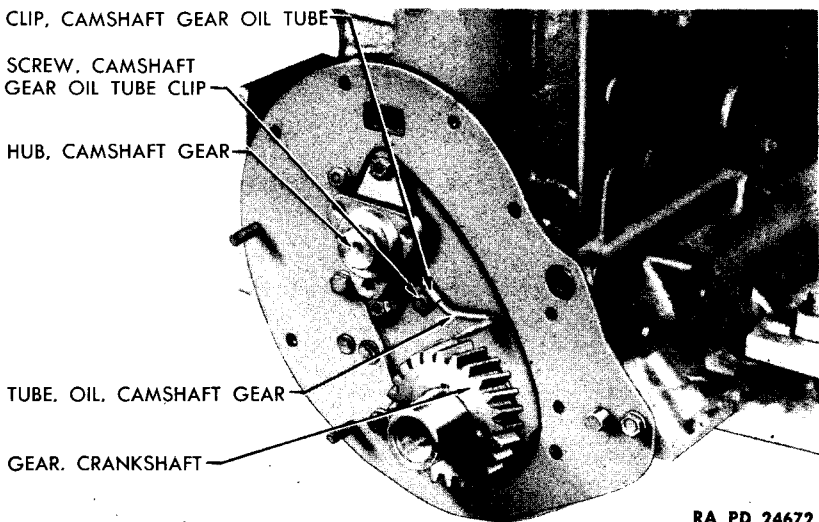


**Figure 103 — Installing Gear Case Cover Plate Gasket**

**ASSEMBLY OF INDIVIDUAL ENGINE**



**Figure 104 — Staking Gear Case Cover Plate Screw In Place**



**Figure 105 — Camshaft Gear Oil Tube In Position**

ORDNANCE MAINTENANCE – POWER UNIT FOR  
MEDIUM TANKS M3A4 AND M4A4

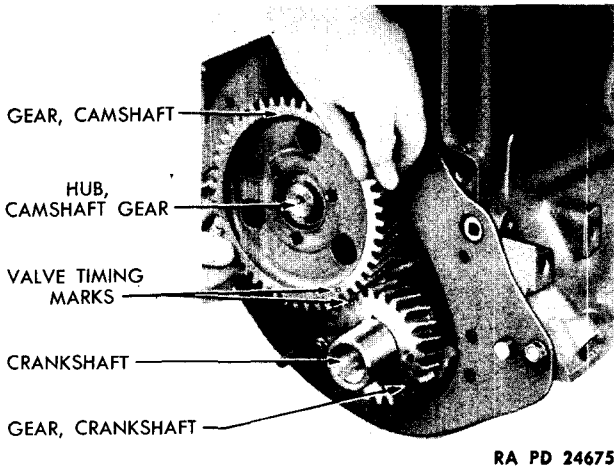


Figure 106 – Installing Camshaft Gear

(12) INSTALL TACHOMETER DRIVE GEAR IN GEAR CASE COVER (NO. 1 ENGINE ONLY).

HAMMER, brass  
WRENCH, 1 1/8-in.

WRENCH, torque

Press tachometer drive gear on shaft and secure with pin through hub (hammer). Install key in keyway in tachometer drive gear support and install gasket on support (fig. 108). Insert drive shaft through support and insert assembly through opening in gear case cover, being sure that key in support is inserted in keyway in cover (fig. 109). Secure assembly in cover with lock washer and nut (1 1/8-in. wrench). *Do not tighten more than 20 foot pounds.*

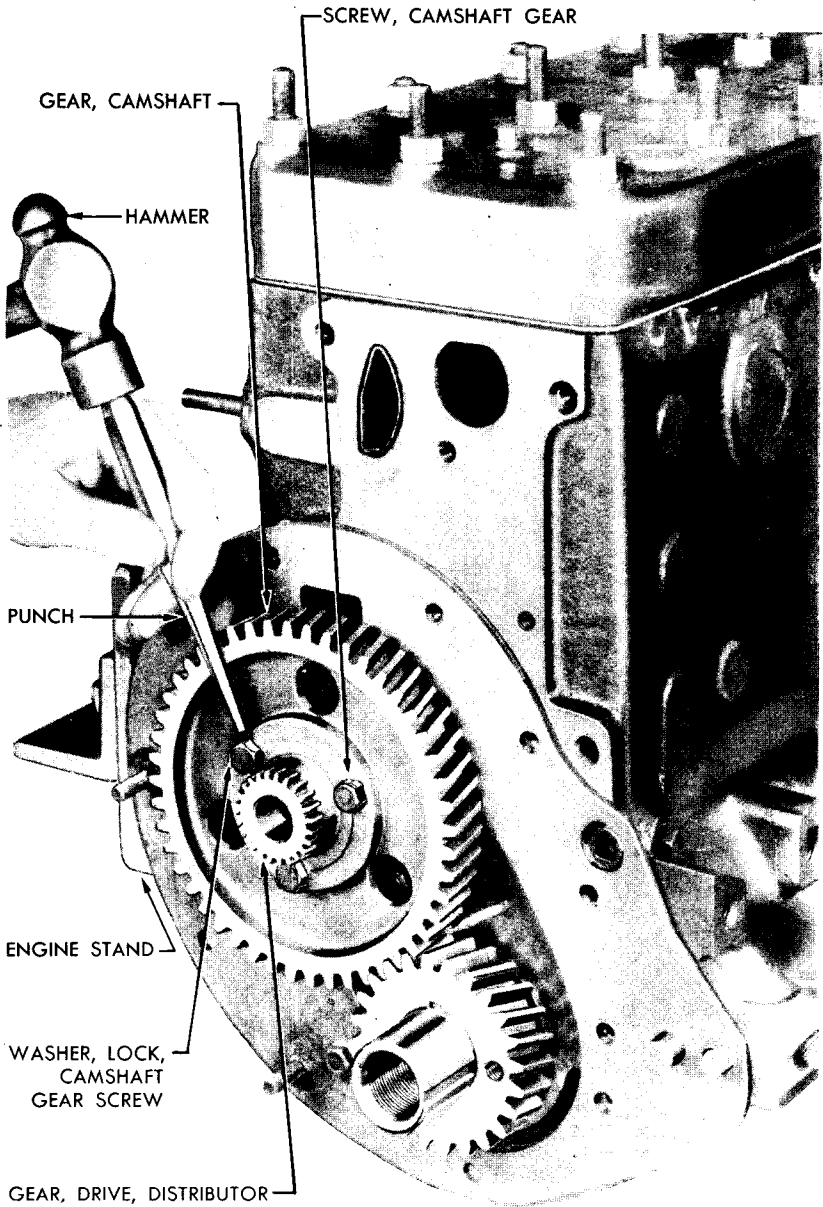
(13) INSTALL GEAR CASE COVER.

DRIFT  
HAMMER, brass  
SCREWDRIVER

TOOL, installing, hub  
WRENCH, 1/2-in.  
WRENCH, torque

Place crankshaft damper hub key in keyway in crankshaft and be sure it seats properly (brass hammer). Position a new gasket in opening and press gear case cover oil seal (fig. 108) into large opening in cover. Position new gasket against gear case cover plate and place cover in position to install. Insert vibration damper hub through opening in cover and press on crankshaft to assist in alining gear case cover. Place a drift in cap screw hole, also to assist in alining cover (fig. 110). Hold cover against the cover plate with one hand and, with a screwdriver in slot in end of tachometer drive shaft, rotate shaft until gears match. Press cover into position on

ASSEMBLY OF INDIVIDUAL ENGINE



RA PD 24687

Figure 107 — Bending Tabs Of Lock Washer

ORDNANCE MAINTENANCE — POWER UNIT FOR  
MEDIUM TANKS M3A4 AND M4A4

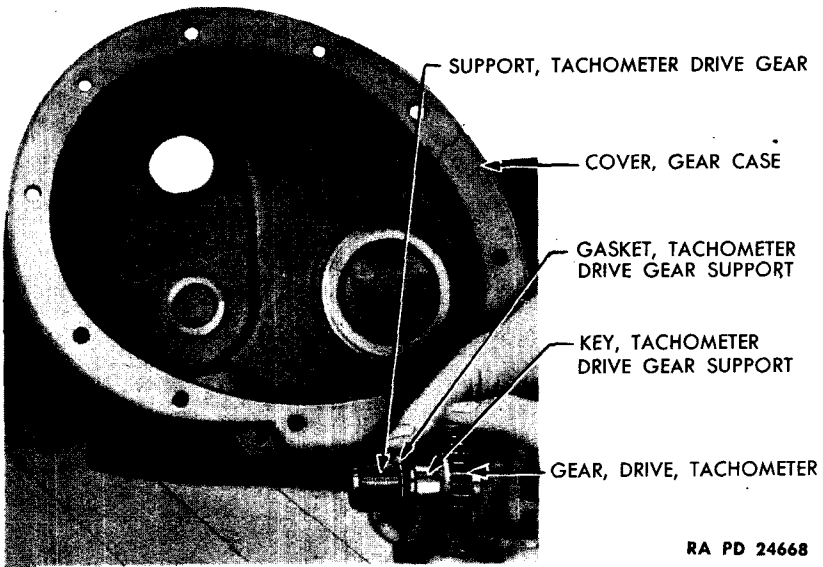


Figure 108 — Tachometer Support Gasket In Position

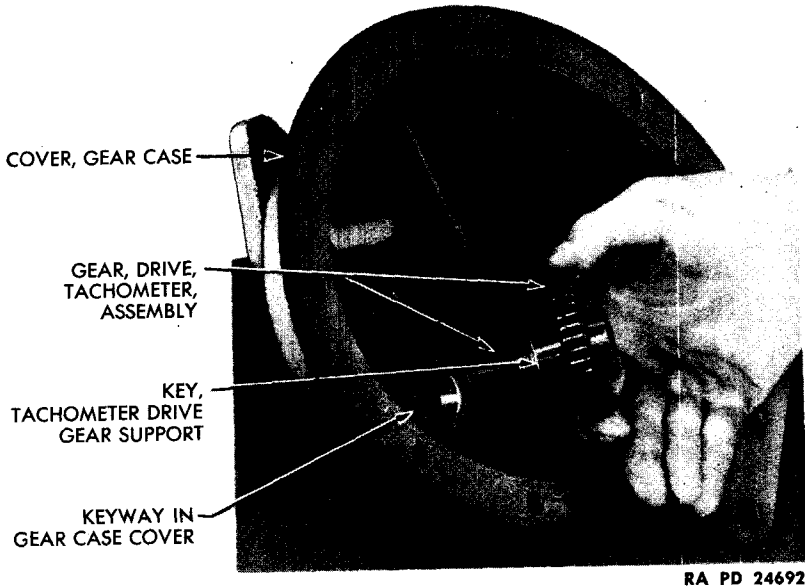
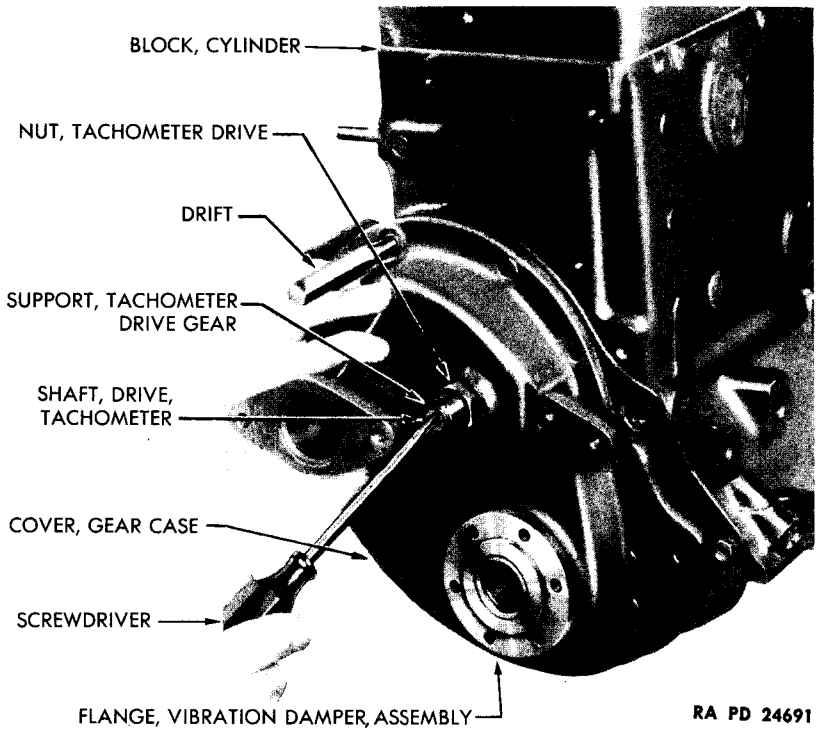


Figure 109 — Installing Tachometer Support In Gear Case Cover

**ASSEMBLY OF INDIVIDUAL ENGINE**



**Figure 110 — Installing Gear Case Cover**

cylinder block. Check backlash of distributor drive gear. Backlash must be a minimum of 1½ degrees. If dowels interfere with assembly with backlash specified, enlarge dowel holes in cover. Paint threads of cap screws with thread sealer. Install cap screws and lock washers and stud nuts and lock washers and tighten to 12 to 17 foot pounds with ½-inch wrench and torque wrench (fig. 111). Install gear case cover dust seal and install hub (fig. 112). Use tool to press hub on shaft, until it rests against shoulder on shaft (fig. 113).

**(14) INSTALL DISTRIBUTOR MOUNTING STUDS (fig. 114).**

**DRIVER and REMOVER, stud**

Insert coarse threaded end of stud in gear case cover and tighten with stud driver.

**(15) INSTALL CRANKSHAFT VIBRATION DAMPER (fig. 115).**

**WRENCH, 7/8-in.**

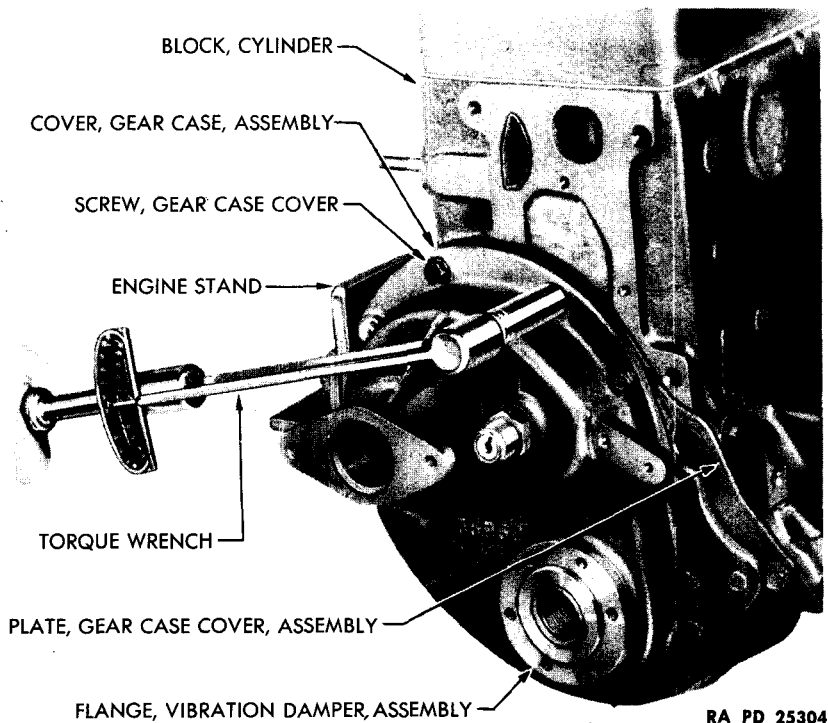
**WRENCH, socket, 1½-in.**

**WRENCH, socket, ¾-in.**

**WRENCH, torque**

Place water pump drive pulley (multiple water pump type only) and vibration damper inertia member in position on hub and secure with 6 cap

ORDNANCE MAINTENANCE — POWER UNIT FOR  
MEDIUM TANKS M3A4 AND M4A4



**Figure 111 — Tightening Gear Case Cover Bolts**

screws. **NOTE:** Mounting holes are unevenly spaced, to assure correct installation. Tighten cap screws to 15 to 20 foot pounds with  $\frac{3}{4}$ -inch socket wrench and torque wrench (fig. 116). **NOTE:** On power units of single water pump type the procedure is identical, except that the drive pulley is not used. Install crankshaft starting jaw and lock washer and tighten to 108 foot pounds minimum with  $1\frac{1}{2}$ -inch socket wrench and torque wrench (figs. 117 and 118). Lock cap screws in place with locking wires (side cutting pliers). Install timing indicator and secure with 2 cap screws and lock washers ( $\frac{7}{8}$ -in. wrench) (fig. 117).

**(16) INSTALL CYLINDER WATER JACKET DRAIN COCKS.**

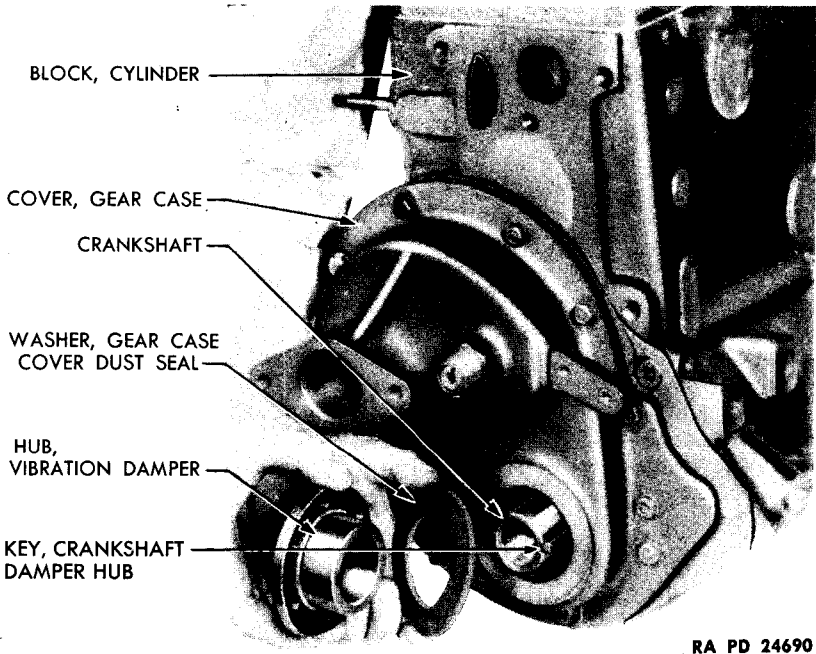
**PLIERS**, side cutting

**WRENCH**, open-end,  $\frac{9}{16}$ -in.

**WRENCH**,  $\frac{1}{2}$ -in.

Paint threads with sealing compound, screw drain cock into opening in end of cylinder block, shown in figures 2 and 3 (on engines 1, 3, 4, and 5 only), and into connection in opening on left side of No. 2 engine, in center of block ( $\frac{9}{16}$ -in. open-end wrench). Close valve (turn clockwise)

**ASSEMBLY OF INDIVIDUAL ENGINE**



RA PD 24690

**Figure 112 – Positioning Vibration Damper Hub And Gasket For Installation**

and secure with locking wire through hole in handle and timing indicator, on engines Nos. 1, 5, and 4 (side cutting pliers). Connect locking wire on No. 2 engine from drain cock handle to connection (side cutting pliers). Connect locking wire on No. 3 engine from drain cock handle to No. 4 manifold stud (side cutting pliers). Screw tube into No. 2 drain cock and attach tube clip to gear case cover attaching screw ( $\frac{1}{2}$ -in. wrench).

**(17) INSTALL WATER DISTRIBUTOR TUBE.**

Insert small end of tube in opening in end of cylinder block and tap with block of wood until end of tube is flush with end of cylinder block.

**(18) INSTALL VALVE COVERS.**

**PLIERS**, side cutting

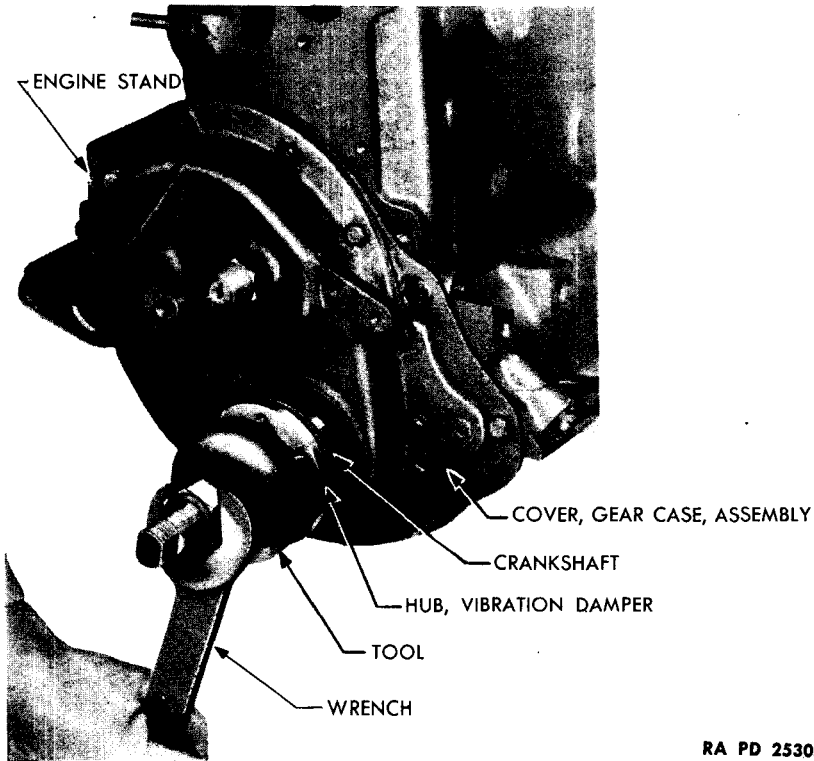
**WRENCH**, torque

**WRENCH**,  $\frac{1}{2}$ -in.

Position new gaskets on cylinder block and attach each cover to cylinder block with 6 cap screws. Tighten cap screws to 15 to 20 foot pounds with  $\frac{1}{2}$ -inch socket wrench and torque wrench. Lock cap screws with locking wires through holes in cap screw heads (side cutting pliers).



**ORDNANCE MAINTENANCE — POWER UNIT FOR  
MEDIUM TANKS M3A4 AND M4A4**



RA PD 25305

**Figure 113 — Installing Vibration Damper Hub**

**(19) INSTALL WATER PUMP (MULTIPLE WATER PUMP TYPE ONLY).**

**HAMMER**, steel

**PUNCH**, prick

**SCREWDRIVER**

**WRENCH**, open-end,  $\frac{7}{16}$ -in.

**WRENCH**, open-end,  $\frac{1}{2}$ -in.

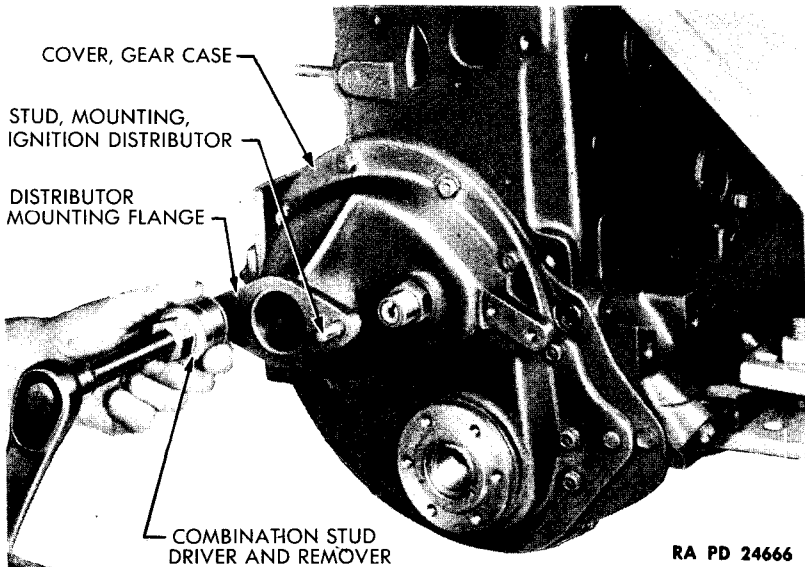
**WRENCH**, open-end,  $\frac{3}{4}$ -in.

**WRENCH**, spanner,

**MTM A4-7**

Paint threads on stud and, using stud driver, screw 2 water pump body studs into cylinder block (No. 1 engine only). Paint mounting faces of water pump body cover plate, and cylinder block (No. 1 engine only) with sealing compound, position new gasket on studs, place cover plate screw and lock washer in upper hole and secure plate to block with flat head screw (fig. 119). Using hammer and prick punch, stake screw in place. Paint mounting faces of plate and pump body with sealing compound, position new gasket on plate, and install body to plate (fig. 120). Install the other 3 water pump body cover screws and tighten ( $\frac{7}{16}$ -in. open-end wrench). Install 2 stud nuts and lock washers and tighten ( $\frac{3}{4}$ -in. open-end wrench). On engines Nos. 2, 3, 4, and 5 (multiple water pump

## ASSEMBLY OF INDIVIDUAL ENGINE



RA PD 24666

**Figure 114 – Removing Or Installing Ignition Distributor Mounting Studs**

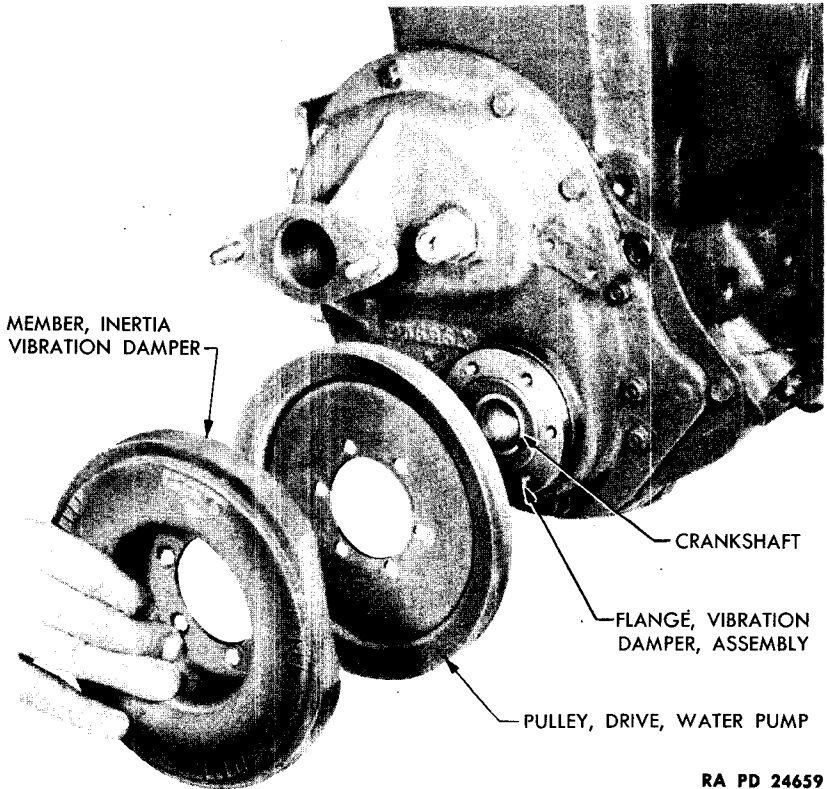
type only) paint mounting faces of cylinder block and water pump body, position new gasket on block and attach pump to block with 3 cap screws and lock washers ( $\frac{3}{4}$ -in. open-end wrench). Place drive belt in groove in drive pulley and slide over hub of pump (fig. 121). Screw water pump driven pulley adjusting flange onto hub (turn counterclockwise). Tighten flange, with spanner wrench MTM A4-7, until there is between  $\frac{1}{2}$ - and  $\frac{5}{8}$ -inch slack in belt when measured by pushing inward midway between water pump and drive pulley. Aline setscrew hole with groove in hub, tighten set screw with screwdriver, and lock with lock nut ( $\frac{1}{2}$ -in. open-end wrench) (fig. 122). NOTE: On No. 2 engine, do not attempt to adjust drive belt until assembly of power unit.

(20) **INSTALL WATER PUMP OUTLET TUBE ADAPTER (SINGLE WATER PUMP TYPE ONLY).**

**WRENCH**, open-end,  $\frac{3}{4}$ -in.

Paint mounting faces of cylinder block and adapter, position new gasket on cylinder block and attach adapter to block with 3 nuts and lock washers.

ORDNANCE MAINTENANCE — POWER UNIT FOR  
MEDIUM TANKS M3A4 AND M4A4



RA PD 24659

**Figure 115 — Installing Vibration Damper**

(21) INSTALL INTAKE AND EXHAUST MANIFOLDS.

WRENCH, extension, 6-in.

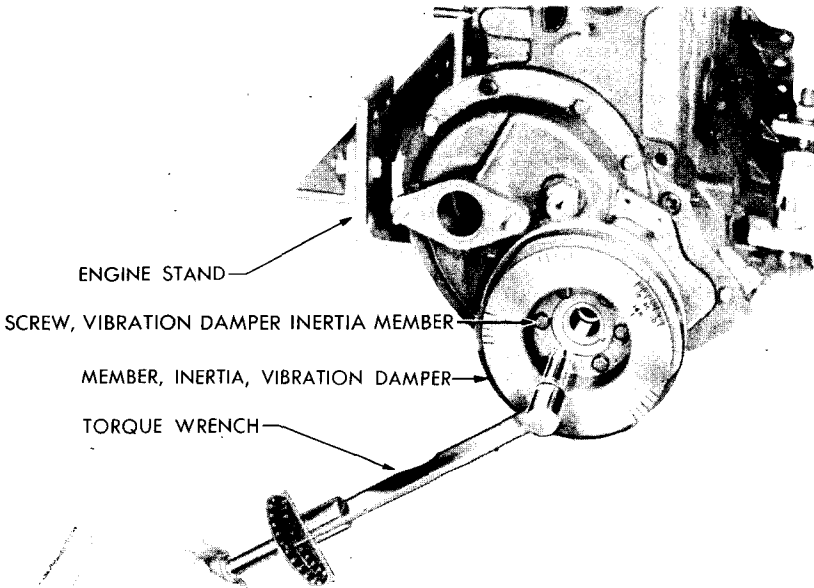
WRENCH, socket,  $\frac{9}{16}$ -in.

WRENCH, open-end,  $\frac{9}{16}$ -in.

WRENCH, torque

Position new gaskets over manifold attaching studs. Slide manifold assembly over studs and force tight against cylinder block. Place brass washer over each end stud, both upper and lower, and install nut. Place clamp washer over each of the remaining upper studs, position washer so it will contact projections on manifolds, and install nuts on studs. Install nuts on the remaining 5 lower studs. Tighten all nuts lightly; then tighten nuts alternately to 15 to 20 foot pounds with  $\frac{9}{16}$ -inch socket, with 6-inch extension and torque wrenches. NOTE: It will be necessary to use a  $\frac{9}{16}$ -inch open-end wrench on some studs, due to restricted clearances. Install pal nuts on all studs, tighten finger-tight and  $\frac{1}{3}$  turn. Tighten the 4 bolts

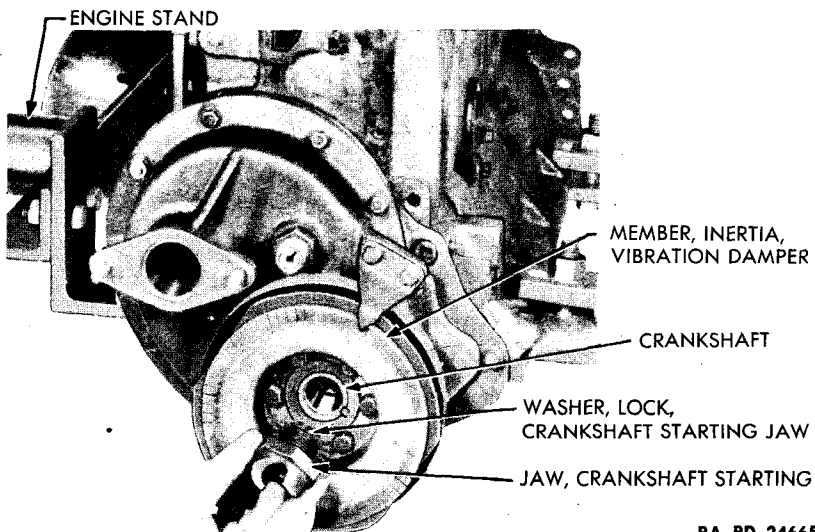
ASSEMBLY OF INDIVIDUAL ENGINE



RA PD 300576

**Figure 116 – Tightening Vibration Damper Cap Screws**

and nuts which secure intake manifold to exhaust manifold ( $\frac{9}{16}$ -in. open-end wrench).



RA PD 24665

**Figure 117 – Installing Crankshaft Starting Jaw**

ORDNANCE MAINTENANCE — POWER UNIT FOR  
MEDIUM TANKS M3A4 AND M4A4

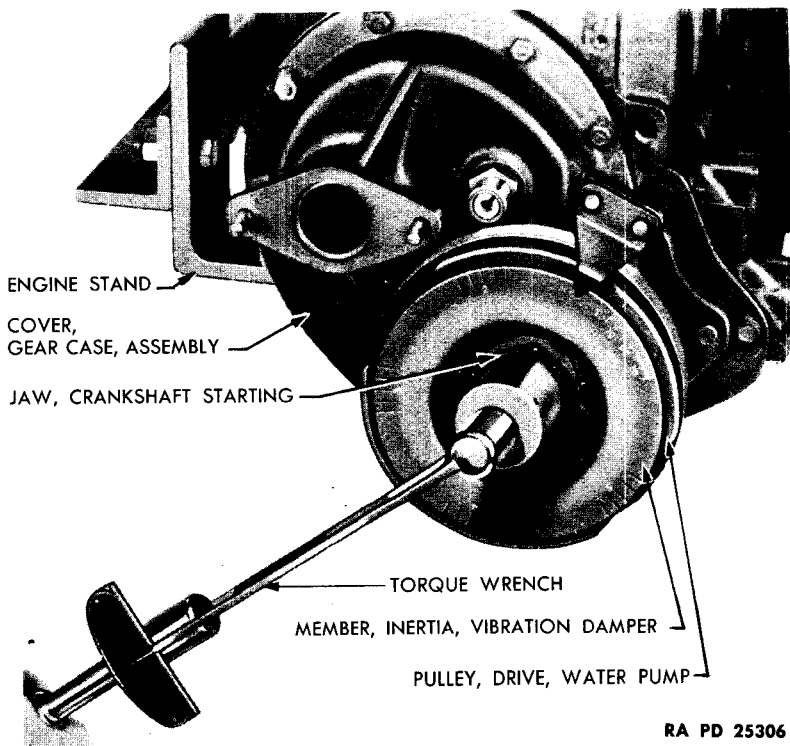


Figure 118 — Tightening Crankshaft Starting Jaw

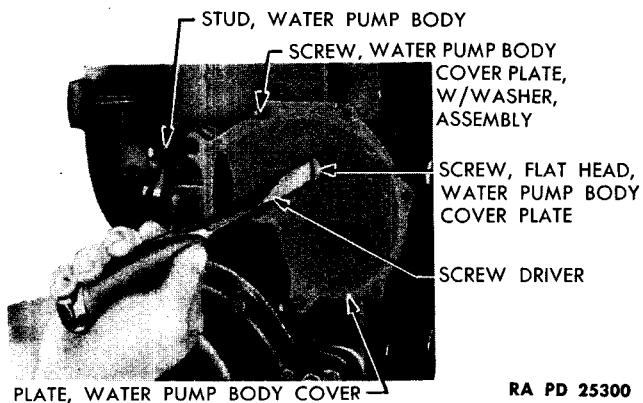
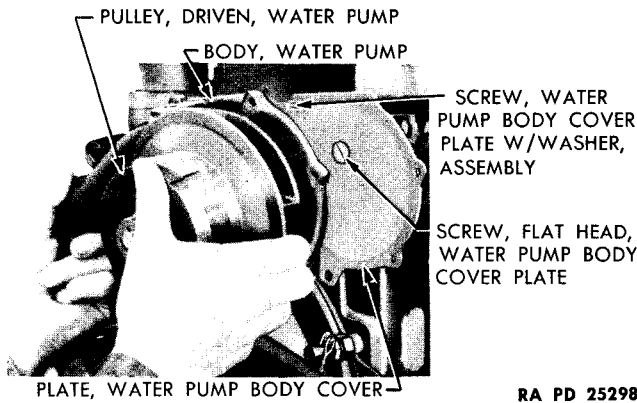


Figure 119 — Installing No. 1 Engine Water Pump Body Cover Plate

**ASSEMBLY OF INDIVIDUAL ENGINE**



RA PD 25298

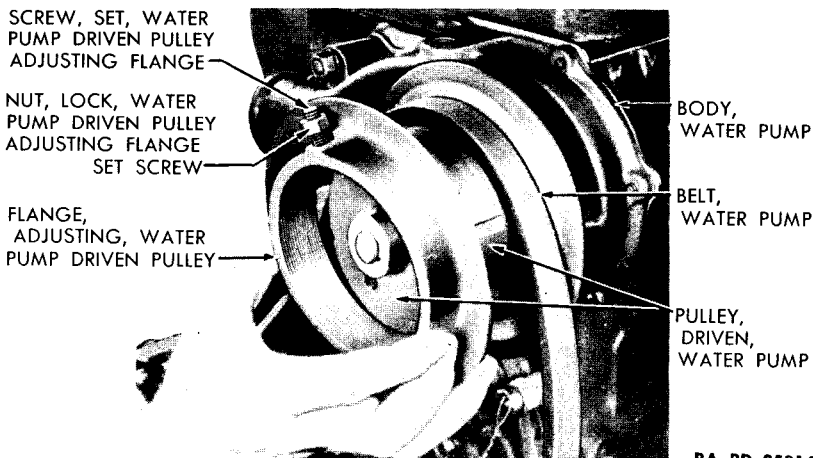
**Figure 120 — Installing No. 1 Engine Water Pump**

**(22) INSTALL CRANKCASE VENT HOLE COVER.**

**NOTE:** Crankcase vent hole covers are used on engines Nos. 2, 3, and 4 only, on power units equipped with ventilator on cylinder block and also No. 1 engine on power units equipped with ventilator in valve spring cover. Position new gasket in opening in left side of cylinder block, at radiator end, and place cover over opening. Place gasket over attaching screw and insert screw through hole in cover and screw into cylinder block ( $\frac{1}{2}$ -in. wrench). Lock screw in place with lock wire (side cutting pliers).

**PLIERS**, side cutting

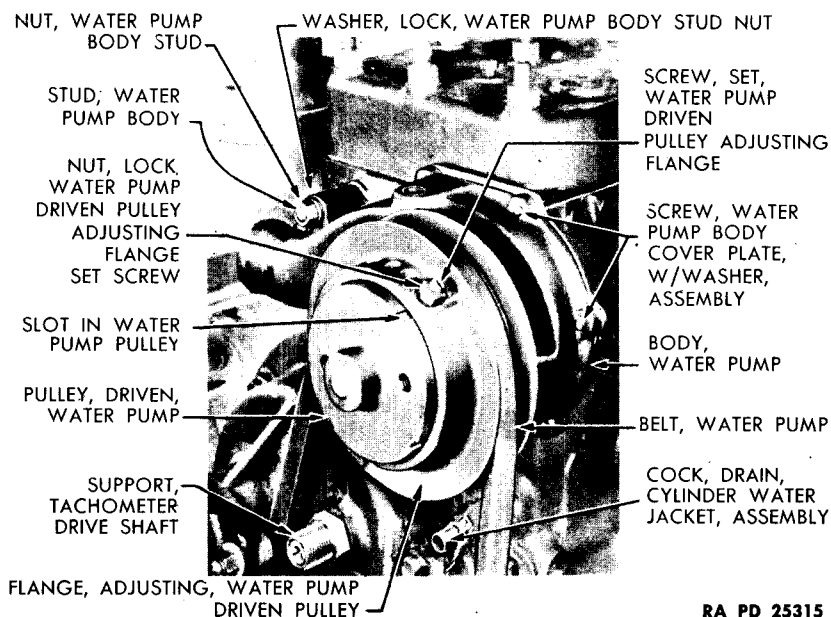
**WRENCH**,  $\frac{1}{2}$ -in.



RA PD 25314

**Figure 121 — Installing Water Pump Driven Pulley Adjusting Flange**

ORDNANCE MAINTENANCE — POWER UNIT FOR  
MEDIUM TANKS M3A4 AND M4A4



RA PD 25315

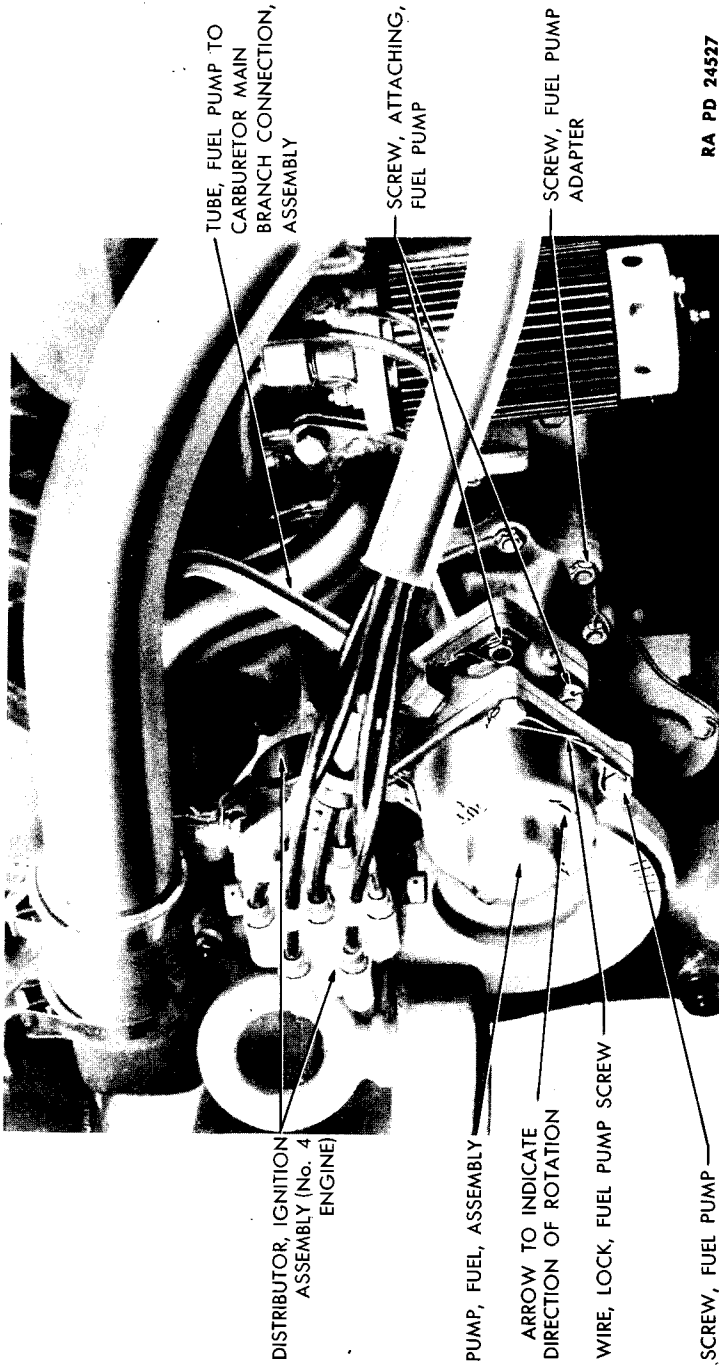
Figure 122 — No. 1 Engine Water Pump In Position

(23) INSTALL DISTRIBUTOR.

WRENCH, open-end,  $\frac{9}{16}$ -in.

Rotate engine crankshaft (counterclockwise) until the mark "I" (stamped on distributor drive gear) starts to appear in the center of the opening into which the distributor shaft is to be mounted (fig. 114). NOTE: Mark "I" on distributor drive gear will appear for setting of No. 1 engine only. For engines Nos. 2, 3, 4, and 5 the mark "O" will appear. With the drive gear so located, the "DC" on vibration damper (fig. 207) will be approaching the timing indicator. Stop rotating the crankshaft when the 4 degrees before "DC" mark alines with pointer (fig. 207). Position new distributor oil seal ring on distributor pilot and insert distributor part way into opening in gear case cover (fig. 114). Rotate distributor until the timing mark "I", on sealing plate, is pointing in the general direction of the cylinder head of engine. Place rotor on distributor shaft, press down full length of travel and turn rotor until the timing marks are alined (fig. 207). Holding rotor in this position, rotate distributor until the mounting studs are approximately in the center of the flange slots in side of distributor assembly base. Insert distributor into timing gear case cover until the gears are fully meshed. NOTE: It

ASSEMBLY OF INDIVIDUAL ENGINE



RA PD 24527

Figure 123 -- Fuel Pump Mounted On No. 4 Engine, Single Water Pump Type Power Unit



**ORDNANCE MAINTENANCE — POWER UNIT FOR  
MEDIUM TANKS M3A4 AND M4A4**

may be necessary to rotate distributor and rotor slightly to permit gears to engage. Secure distributor with 2 flat washers and nuts. Tighten nuts securely with  $\frac{3}{16}$ -inch wrench.

(24) **INSTALL FUEL PUMP (No. 4 ENGINE ONLY) (SINGLE WATER PUMP TYPE)** (fig. 123).

**PLIERS**, side cutting

**WRENCH**, open-end,  $\frac{1}{2}$ -in.

Position new gasket on gear case cover and secure fuel pump adapter to cover with 7 cap screws. **NOTE:** Paint threads of cap screws which enter water jacket with a suitable sealing compound. Tighten cap screws to 15 to 20 foot pounds with  $\frac{1}{2}$ -inch wrench and torque wrench. Position new gasket on adapter and secure pump to adapter with 4 cap screws. Tighten cap screws to 15 to 20 foot pounds with  $\frac{1}{2}$ -inch wrench and torque wrench. Secure cap screws on adapter and pump with locking wires (side cutting pliers).

(25) **INSTALL TACHOMETER DRIVE REDUCTION GEAR ASSEMBLY (No. 1 ENGINE ONLY)** (fig. 2).

**GUN**, grease

**WRENCH**, open-end,  $1\frac{1}{8}$ -in.

With grease gun applied to lubrication fitting on reduction drive gear, force **GREASE**, general purpose, No. 1, through fitting until grease is forced out through relief fitting on opposite side of drive gear. Insert end of drive shaft into opening in shaft in gear case cover and screw connection onto tachometer drive shaft support ( $1\frac{1}{8}$ -in. open-end wrench).

Section VIII

**ASSEMBLY OF POWER UNIT**

	Paragraph
General .....	24
Assembly of power unit.....	25

**24. GENERAL.**

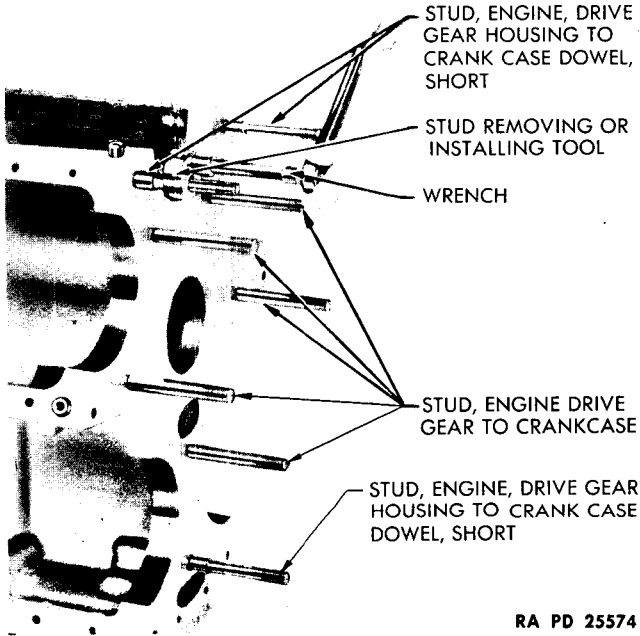
a. A stand, to receive the crankcase, which will permit assembling of the 5 individual engines to the crankcase, should be provided. In the event a stand is not available, support the crankcase on wood blocks in such a manner that the assembly can be rotated to permit assembling of the individual engines to the crankcase. All parts should be cleaned thoroughly with SOLVENT, dry-cleaning, and all oil passages checked for obstructions.

**25. ASSEMBLY OF POWER UNIT.**

a. **Equipment.**

- |   |   |
|---|---|
| BAR, pinch  | INDICATOR, timing   |
| CAN, oil  | PAN, for SOLVENT,<br>dry-cleaning                                 |
| DRIFT   | PLATE, MTM-A4-38  |
| DRIFT, feeler   | PLIERS, side cutting  |
| DRIFT, main drive shaft front<br>bearing installing,<br>MTM-A4-14 | PRESS   |
| DRILL   | PRESS, arbor  |
| DRIVER, drive gear stub,<br>MTM-A4-43                             | SCREWDRIVER   |
| DRIVER, gear box main drive<br>gear and bearing,<br>MTM-A4-45     | SLING, engine assembly hoist,<br>MTM-A4-18                        |
| DRIVER, stud  | SPACER, accessory drive shaft<br>bevel gear setting,<br>MTM-A4-21 |
| GAGE and INDICATOR,<br>master drive gear setting,<br>MTM-A4-19    | STAND, overhaul,<br>MTM-A4-29                                     |
| GAGE, feeler  | TOOL, drive gear alining,<br>MTM-A4-39                            |
| GUN, grease   | WRENCH, $\frac{3}{8}$ -in.  |
| HAMMER  | WRENCH, $\frac{1}{2}$ -in.  |
| HAMMER, steel   | WRENCH, $\frac{9}{16}$ -in.                                       |
| HOIST   | WRENCH, $\frac{5}{8}$ -in.  |
| INDICATOR, dial   | WRENCH, $\frac{11}{16}$ -in.                                      |
|   | WRENCH, $\frac{7}{8}$ -in.  |

**ORDNANCE MAINTENANCE – POWER UNIT FOR  
MEDIUM TANKS M3A4 AND M4A4**



RA PD 25574

**Figure 124 – Removing Or Installing Drive Gear Housing  
To Crankcase Studs**

WRENCH,  $\frac{1}{8}$ -in.

WRENCH, 1-in.

WRENCH, accessory drive shaft bevel gear lock nut, MTM-A4-3

WRENCH and EXTENSION, lower engine block to crankcase, MTM-A4-11

WRENCH, bull shaft bearing lock nut, MTM-A4-1

WRENCH, drive front bearing lock nut, MTM-A4-2

WRENCH, open-end,  $\frac{7}{8}$ -in.

WRENCH, open-end,  $\frac{1}{2}$ -in.

WRENCH, open-end,  $\frac{9}{8}$ -in.

WRENCH, open-end,  $\frac{5}{8}$ -in.

WRENCH, open-end,  $\frac{1}{4}$ -in.

WRENCH, open-end-  $\frac{3}{4}$ -in.

WRENCH, open-end, 1-in.

WRENCH, pipe, 16-in.

WRENCH, socket,  $\frac{1}{2}$ -in.

WRENCH, socket,  $\frac{9}{16}$ -in. (2)

WRENCH, socket,  $\frac{5}{8}$ -in.

WRENCH, socket,  $\frac{23}{32}$ -in.

WRENCH, socket,  $\frac{3}{4}$ -in.

WRENCH, socket,  $\frac{7}{8}$ -in.

WRENCH, socket,  $\frac{15}{16}$ -in.

WRENCH, socket, 1-in.

WRENCH, socket, 2  $\frac{1}{8}$ -in.

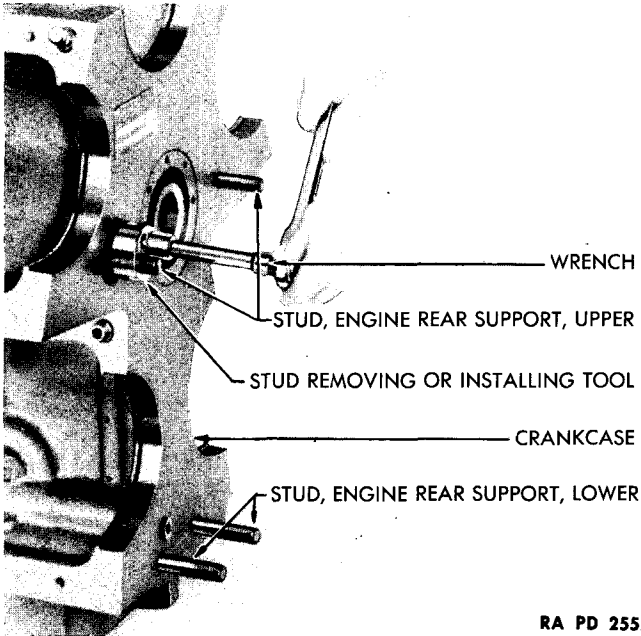
WRENCH, spanner

WRENCH, square plug,  $\frac{1}{2}$ -in.

WRENCH, square plug,  $\frac{3}{8}$ -in.

WRENCH, torque

**ASSEMBLY OF POWER UNIT**



RA PD 25577

**Figure 125 – Removing Or Installing Power Unit Rear Support To Crankcase Studs**

**b. Procedure.**

(1) **INSTALL DRIVE GEAR HOUSING MOUNTING STUDS AND POWER UNIT REAR SUPPORT MOUNTING STUDS.**

**DRIVER, stud**

**WRENCH, socket, 1-in.**

Insert 1 doweled stud at each upper hole in radiator end of crankcase and 1 doweled stud at bottom hole in radiator end of crankcase. Install the 5 plain studs in the other 5 holes in radiator end of case (fig. 124). Use a stud driver to tighten all studs to crankcase. Insert the 2 long power unit rear support mounting studs in the 2 lower holes, and the 2 short studs in the 2 upper holes in the distributor end of the crankcase. Use a stud driver to tighten the studs to the crankcase (fig. 125). Position rear support over the 4 studs and secure with lock washers and nuts.

(2) **ASSEMBLE ACCESSORY DRIVE SHAFT GEARS ON SHAFT (fig. 126).**

**DRIFT**

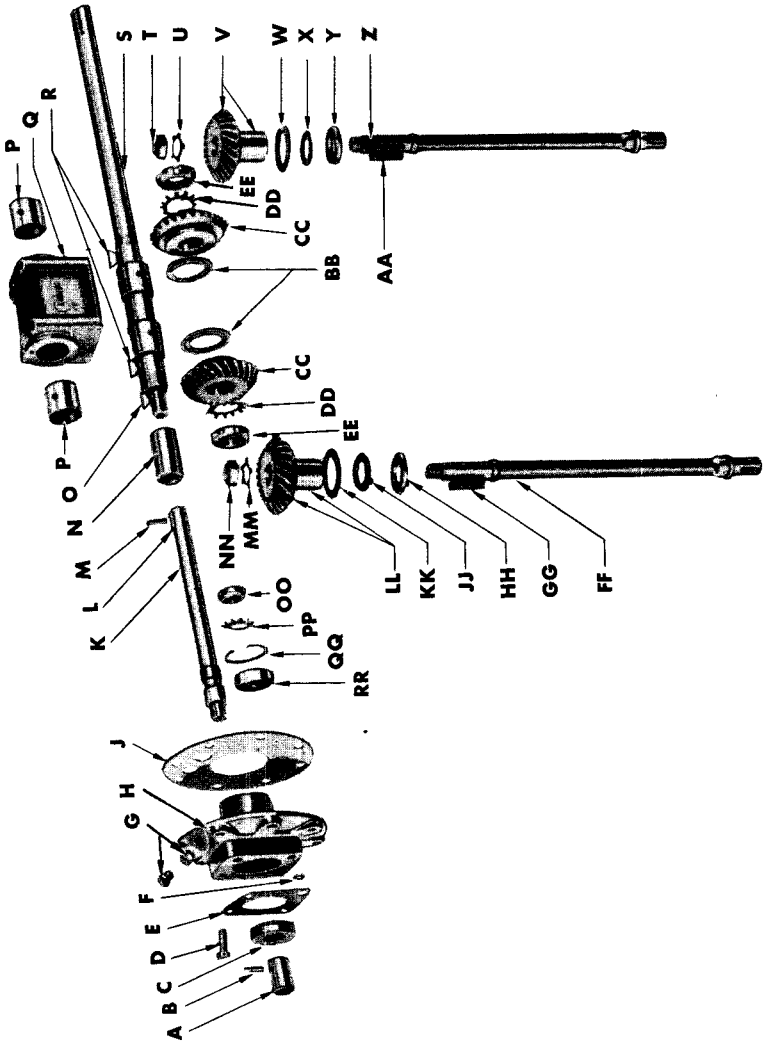
**PRESS**

**HAMMER, steel**

**WRENCH, spanner**

Remove all burrs from accessory drive shaft. Select the accessory drive shaft gear for installation on the short end of the shaft, as indicated by

ORDNANCE MAINTENANCE — POWER UNIT FOR  
MEDIUM TANKS M3A4 AND M4A4



RA PD 300577

Figure 126 — Fuel Pump Drive Assembly And Accessory Drive Shaft Assembly, Exploded

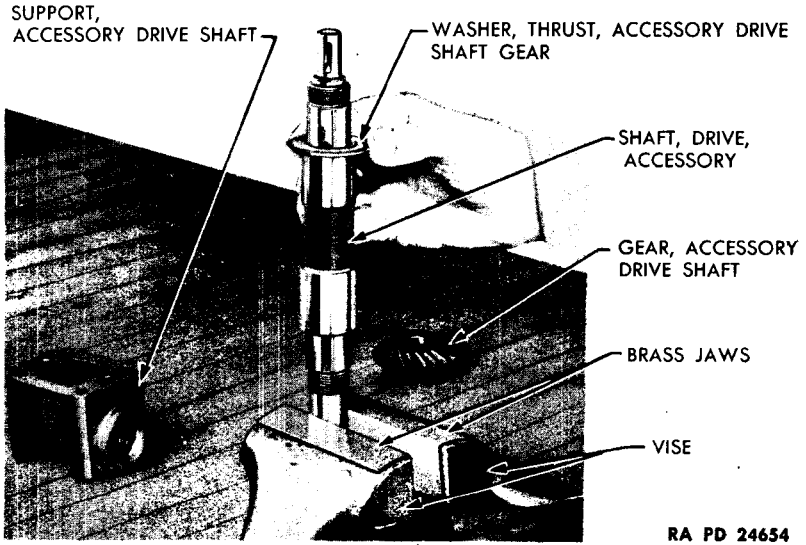
ASSEMBLY OF POWER UNIT.

- |   |   |
|---|---|
| A—SLEEVE, COUPLING, FUEL PUMP DRIVE         | W—WASHER, THRUST, OIL SCAVENGER PUMP DRIVE SHAFT GEAR |
| B—PIN, FUEL PUMP DRIVE COUPLING SLEEVE      | X—WASHER, THRUST, OIL SCAVENGER PUMP DRIVE SHAFT      |
| C—SEAL, OIL, FUEL PUMP DRIVE SHAFT BEARING  | Y—WASHER, OIL SCAVENGER PUMP DRIVE SHAFT              |
| D—SCREW, FUEL PUMP ADAPTER                  | Z—SHAFT, OIL SCAVENGER PUMP DRIVE                     |
| E—GASKET, FUEL PUMP                         | AA—KEY, OIL SCAVENGER PUMP DRIVE SHAFT GEAR           |
| F—WASHER, LOCK, FUEL PUMP ADAPTER SCREW     | BB—WASHER, THRUST, ACCESSORY DRIVE SHAFT GEAR         |
| G—PLUG, FUEL PUMP ADAPTER                   | CC—GEAR, ACCESSORY DRIVE SHAFT                        |
| H—ADAPTER, FUEL PUMP                        | DD—WASHER, LOCK, ACCESSORY DRIVE SHAFT NUT            |
| J—GASKET, FUEL PUMP ADAPTER                 | EE—NUT, ACCESSORY DRIVE SHAFT                         |
| K—SHAFT, FUEL PUMP DRIVE                    | FF—SHAFT, OIL PRESSURE PUMP DRIVE                     |
| L—KEY, FUEL PUMP DRIVE SHAFT                | GG—KEY, OIL PRESSURE PUMP DRIVE SHAFT GEAR            |
| M—PIN, FUEL PUMP DRIVE SHAFT KEY            | HH—WASHER, OIL PRESSURE PUMP DRIVE SHAFT              |
| N—SLEEVE, ACCESSORY DRIVE SHAFT             | JJ—WASHER, THRUST, OIL PRESSURE PUMP DRIVE SHAFT      |
| O—KEY, ACCESSORY DRIVE SHAFT SLEEVE         | KK—WASHER, THRUST, OIL PRESSURE PUMP DRIVE SHAFT GEAR |
| P—BUSHING, ACCESSORY DRIVE SHAFT            | LL—GEAR, OIL PRESSURE PUMP DRIVE SHAFT                |
| Q—SUPPORT, ACCESSORY DRIVE SHAFT            | MM—LOCK, OIL PRESSURE PUMP DRIVE SHAFT GEAR NUT       |
| R—KEY, ACCESSORY DRIVE SHAFT GEAR           | NN—NUT, OIL PRESSURE PUMP DRIVE SHAFT GEAR            |
| S—SHAFT, ACCESSORY DRIVE                    | OO—NUT, FUEL PUMP DRIVE SHAFT BEARING                 |
| T—NUT, OIL SCAVENGER PUMP DRIVE SHAFT GEAR  | PP—WASHER, LOCK, FUEL PUMP DRIVE SHAFT BEARING NUT    |
| U—LOCK, OIL SCAVENGER PUMP DRIVE SHAFT GEAR | QQ—SNAP RING, FUEL PUMP DRIVE SHAFT BEARING           |
| V—GEAR, OIL SCAVENGER PUMP DRIVE SHAFT      | RR—BEARING, FUEL PUMP DRIVE SHAFT                     |

RA PD 300577B

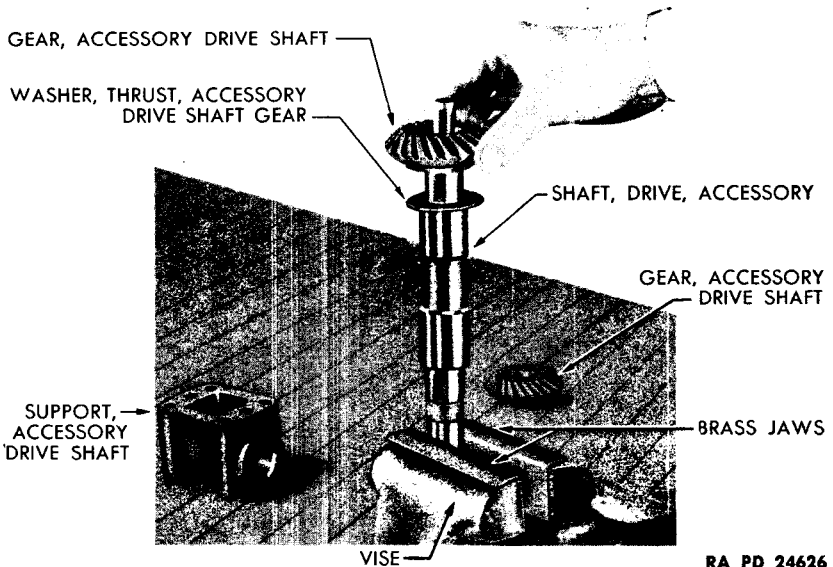
Legend For Figure 126 — Fuel Pump Drive Assembly And Accessory Drive Shaft Assembly, Exploded

ORDNANCE MAINTENANCE – POWER UNIT FOR  
MEDIUM TANKS M3A4 AND M4A4



RA PD 24654

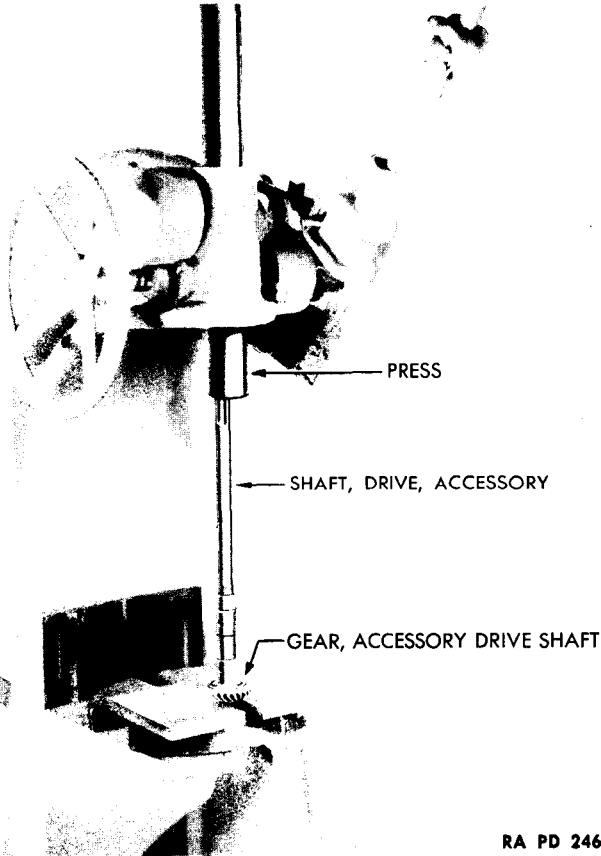
Figure 127 – Installing Accessory Drive Shaft Gear Thrust Washer On Shaft



RA PD 24626

Figure 128 – Installing Accessory Drive Shaft Gear On Shaft

ASSEMBLY OF POWER UNIT



RA PD 24628

**Figure 129 – Pressing Accessory Drive Shaft Gear On Shaft**

prick punch marks, install the key in shaft, place thrust washer in position on shaft (fig. 127), install and press gear on shaft until it contacts shoulder on shaft (figs. 128 and 129). Install lock washer and nut, tighten nut with spanner wrench (fig. 130), and bend tabs of lock washer to secure nut (hammer and drift) (fig. 131). **NOTE:** If new thrust washers are to be used, check thickness, being sure to use 2 washers of the same thickness (one on each side of the support). Washers are furnished in 0.080 to 0.103 inch thickness.

**(3) INSTALL ACCESSORY DRIVE SHAFT IN SUPPORT.**

**DRIFT**

**WRENCH**, accessory drive shaft bevel gear lock nut,

**HAMMER**

**MTM-A4-3**

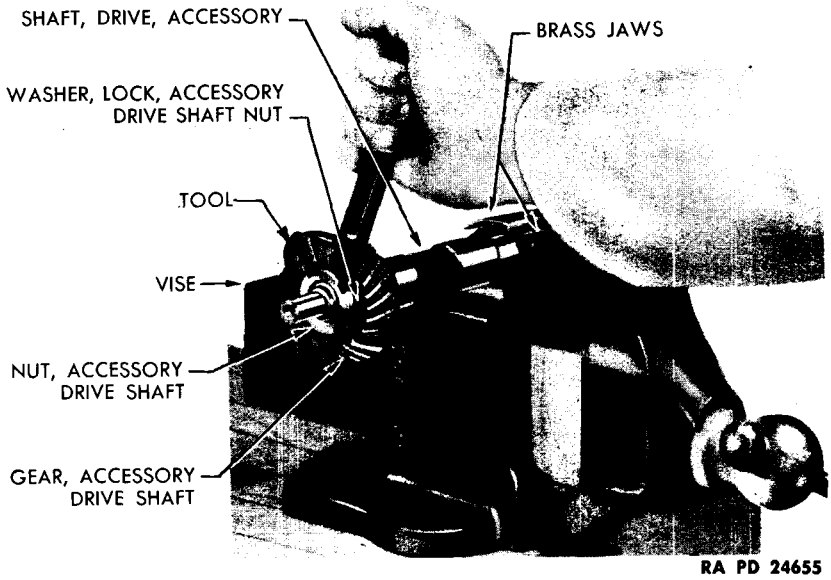
**SPACER**, accessory drive shaft

bevel gear setting,

**MTM-A4-21**

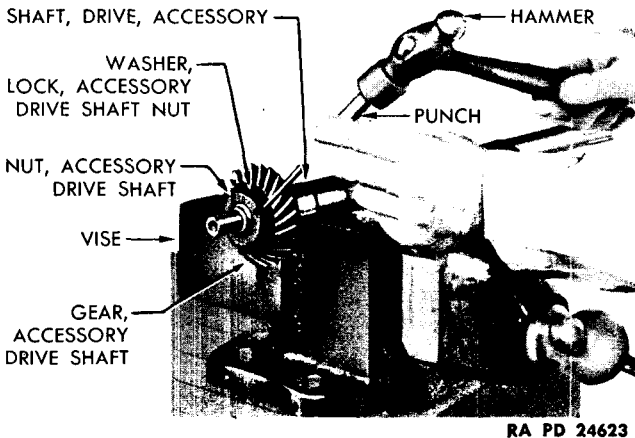


**ORDNANCE MAINTENANCE – POWER UNIT FOR  
MEDIUM TANKS M3A4 AND M4A4**

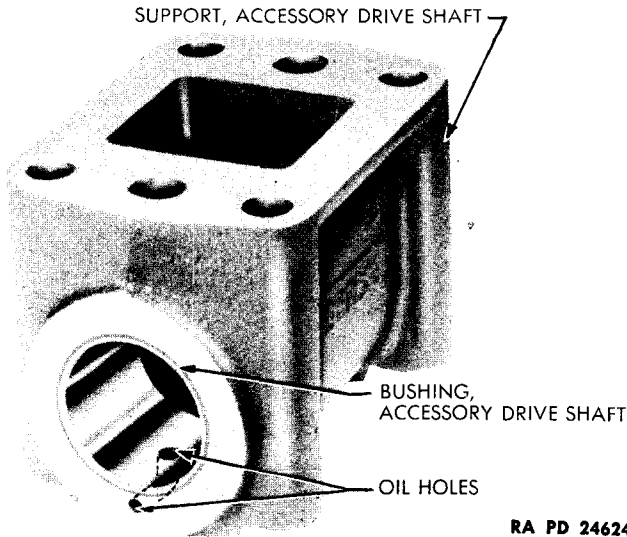


**Figure 130 – Tightening Accessory Drive Shaft Nut**

Check oilholes in accessory drive shaft support, being certain that oilholes, as shown in figures 132 and 133, are free from obstructions. Insert shaft through support (*from end of support which faces distributor end of crankcase, when installed*), install thrust washer on shaft and check end play by installing spacer (MTM-A4-21) on shaft and tightening assembly with lock washer and nut, as shown in figure 134 (feeler gage).



**Figure 131 – Bending Tabs Of Accessory Drive Shaft Nut Lock Washer**

**ASSEMBLY OF POWER UNIT**

**Figure 132 – Accessory Drive Shaft Support, Bottom**

**NOTE:** The length of this tool is the same as the gear, while the inside diameter is of sufficient size to permit easy installation on shaft. This end play must be held between 0.003 inch and 0.005 inch. (Use correct thrust washers until correct end play is obtained). When the correct end play is obtained, remove nut, lock washer, and spacer, install key in shaft, and press gear on shaft (fig. 135), securing with lock washer and nut. Bend tabs of lock washers to secure nut.

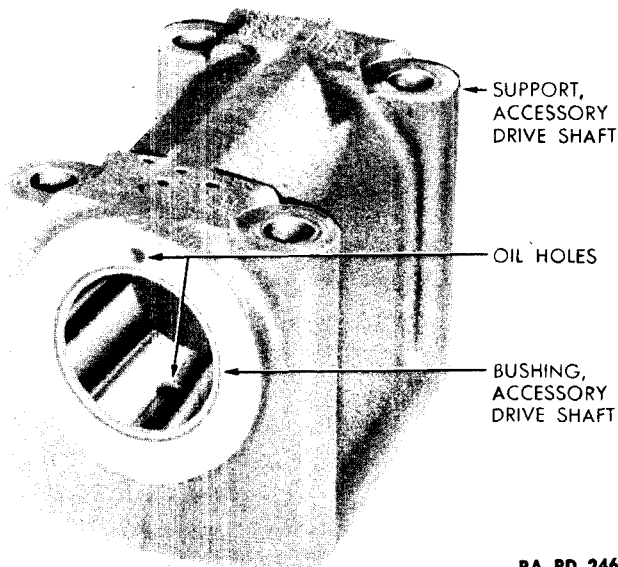
**(4) CHECK BACKLASH BETWEEN ACCESSORY DRIVE SHAFT GEARS AND OIL PUMP DRIVE SHAFT GEARS.**

**INDICATOR, dial**

**WRENCH, socket,  $\frac{5}{8}$ -in.**

Place an oil pump drive shaft gear thrust washer of 0.080-inch thickness on each oil pump drive shaft gear and place gear and washer in openings in crankcase (reach through opening for No. 1 engine) (fig. 136). Check rotation of gears, to be sure they rotate freely. Place accessory drive shaft assembly in position, as shown in figure 137, and secure the assembly to crankcase with 4 bolts ( $\frac{5}{8}$ -in. socket wrench). With dial indicator resting on tooth of oil pump drive shaft gear, check the backlash between the accessory drive shaft gears and the oil pump drive shaft gears. Hold this backlash between limits of 0.005 inch and 0.010 inch. These thrust washers are available in 0.080 inch to 0.103 inch thickness. Select the correct washer until the correct backlash is obtained. Remove bolts and remove accessory drive shaft assembly from crankcase ( $\frac{5}{8}$ -in.

**ORDNANCE MAINTENANCE — POWER UNIT FOR  
MEDIUM TANKS M3A4 AND M4A4**



RA PD 24622

**Figure 133 — Accessory Drive Shaft Support, Top**

socket wrench). Remove oil pump drive gears and washers from crankcase, but do not separate washers from gears. Mark gears for identification when reassembling.

(5) **INSTALL OIL PRESSURE AND OIL SCAVENGER PUMP DRIVE SHAFTS** (fig. 137).

**DRIFT**

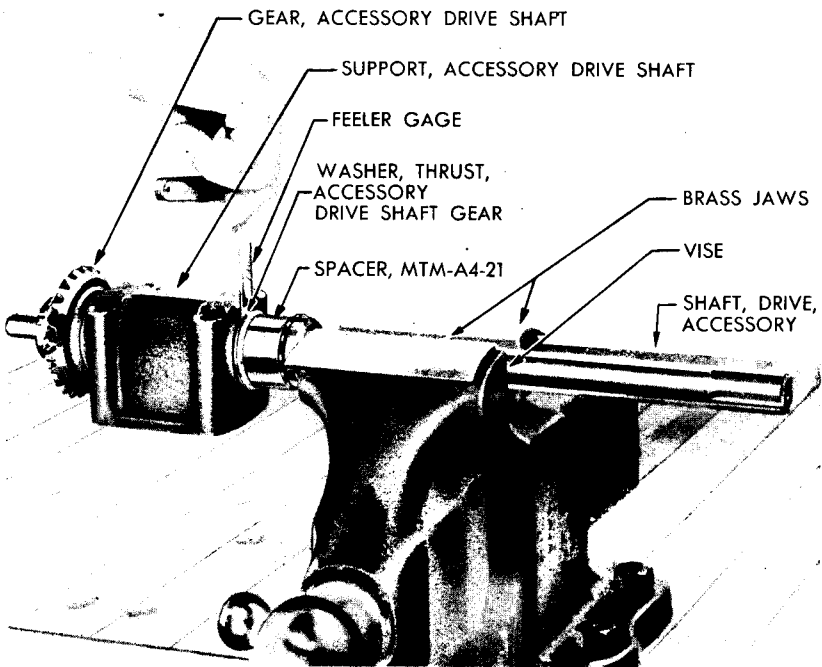
**HAMMER**, steel

**GAGE**, feeler

**WRENCH**, socket,  $\frac{1}{8}$ -in.

Place oil pressure pump drive shaft washer on oil pressure pump shaft, allowing it to rest on shoulder on shaft on oil pump end. Place oil pressure pump drive shaft thrust washer (0.086-in. thick) on shaft and insert shaft through opening in crankcase (from bottom of crankcase). Support shaft (at pump end), install key in upper end of shaft, and tap gear and washer in place on shaft (hammer and drift). Install lock washer and nut. Tighten nut securely ( $\frac{1}{8}$ -in. socket wrench). Using a feeler gage, check end play in drive shaft, as shown in figure 138. The correct end play is 0.004 inch to 0.008 inch. Change the thrust washer on the lower end of shaft to obtain the desired end play. These washers are furnished in thicknesses of 0.080 inch to 0.103 inch. Use hammer and drift to bend tabs of lock washer to secure nut in place. Repeat above operations to install oil scavenger pump drive shaft and gear.

**ASSEMBLY OF POWER UNIT**



RA PD 24656

**Figure 134 – Checking End Play In Accessory Shaft**

**(6) INSTALL ACCESSORY DRIVE SHAFT ASSEMBLY.**

**HAMMER**

**PLIERS**, side cutting

**PRESS**, bench

**WRENCH**, socket,  $\frac{5}{8}$ -in.

**WRENCH**, torque

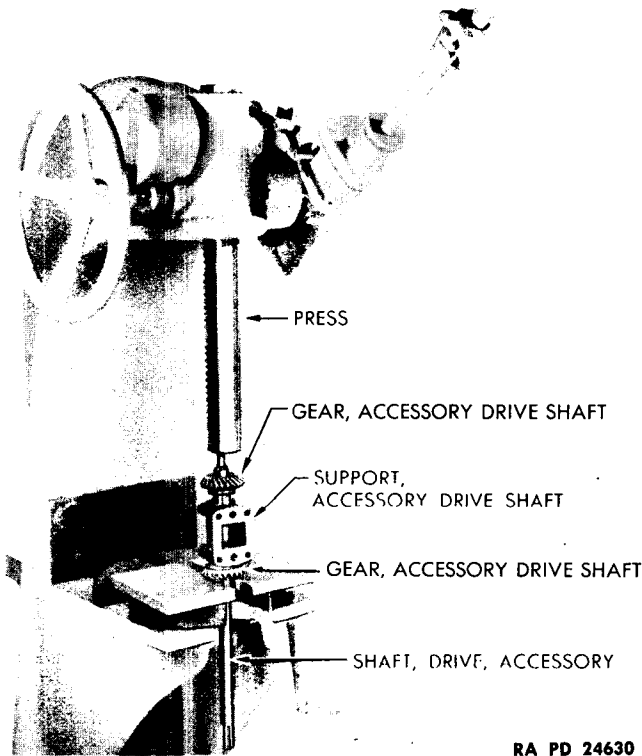
Press fuel pump drive coupling sleeve on accessory drive shaft and, using hole in one side of sleeve, drill hole through shaft and other side of sleeve to receive pin. Install pin and rivet with hammer. Use compressed air to blow any dirt or foreign matter from the accessory drive shaft support dowels (fig. 136). These dowels are hollow and provide lubrication for the accessory shaft, therefore the openings must be free of any obstructions. Position accessory drive shaft assembly in crankcase, as shown in figure 137, and secure with 4 cap screws. Tighten cap screws 30 to 35 foot pounds with  $\frac{5}{8}$ -inch socket wrench. Insert lock wires through holes in cap screws and secure (fig. 139).

**(7) INSTALL FUEL PUMP ADAPTER (MULTIPLE WATER PUMP TYPE ONLY).**

**WRENCH**, socket,  $\frac{1}{2}$ -in.

Position gasket on adapter body and insert shaft through opening in distributor end of crankcase. Aline key in shaft with keyway in sleeve on

ORDNANCE MAINTENANCE — POWER UNIT FOR  
MEDIUM TANKS M3A4 AND M4A4



RA PD 24630

**Figure 135 — Pressing Accessory Drive Shaft Gear On Shaft**

end of accessory drive shaft, insert shaft in sleeve and secure adapter to crankcase with 8 cap screws and lock washers (tighten cap screws to 15 to 20 foot pounds).

**(8) INSTALL WATER PUMP (SINGLE WATER PUMP TYPE ONLY)**  
(fig. 3).

GUN, grease

SCREWDRIVER

WRENCH,  $\frac{1}{8}$ -in.

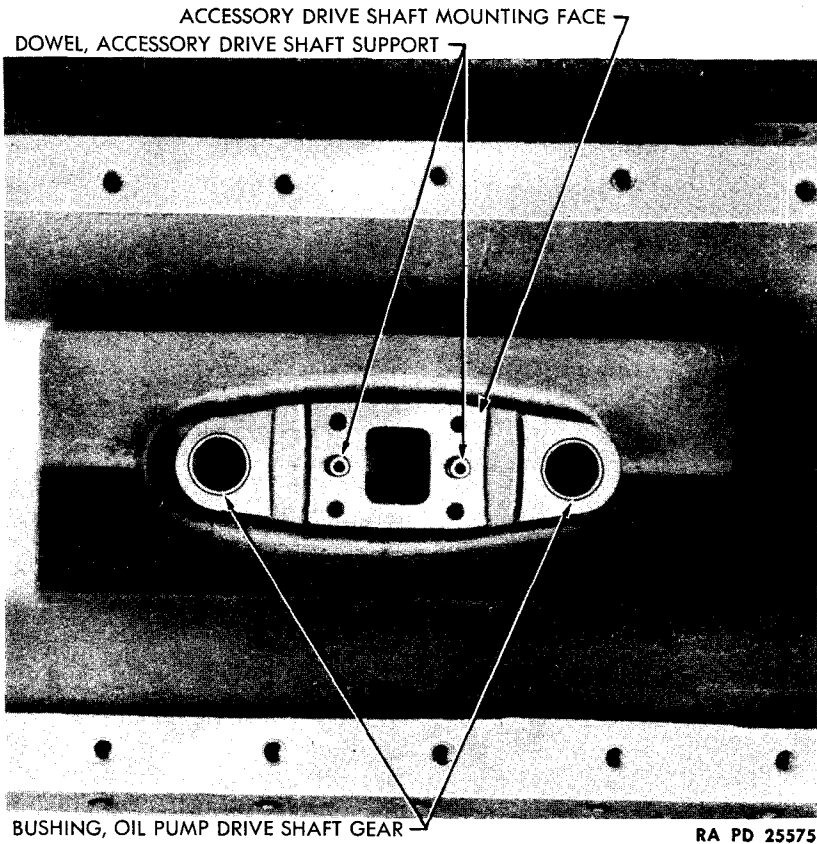
WRENCH, open-end,  $\frac{1}{2}$ -in.

WRENCH, open-end,  $\frac{3}{16}$ -in.

WRENCH, torque

Apply grease gun to lubrication fitting and force GREASE, general purpose, into fitting until it is forced through other side of bearings. Remove hexagonal plug from center of pump body ( $\frac{1}{8}$ -in. wrench). Place splined sleeve on accessory drive shaft. Paint mounting faces on both crankcase and water pump body with sealer. Position new gasket on mounting face of pump. Place pump in position on crankcase, insert screw-

**ASSEMBLY OF POWER UNIT**



**Figure 136 — Mounting Pad For Accessory Drive Shaft**

driver through opening in pump body, contact slot in end of shaft, with screwdriver, and rotate shaft while assembling pump to crankcase, to aline splines. Secure with 7 nuts and lock washers. If  $\frac{3}{8}$ -inch studs are used, tighten nuts to 30 to 35 foot pounds with  $\frac{9}{16}$ -inch open-end wrench and torque wrench. If  $\frac{5}{16}$ -inch studs are used, tighten nuts to 15 to 20 foot pounds with  $\frac{1}{2}$ -inch open-end wrench and torque wrench. Install hexagonal plug in center of pump body and tighten with  $\frac{11}{8}$ -inch wrench.

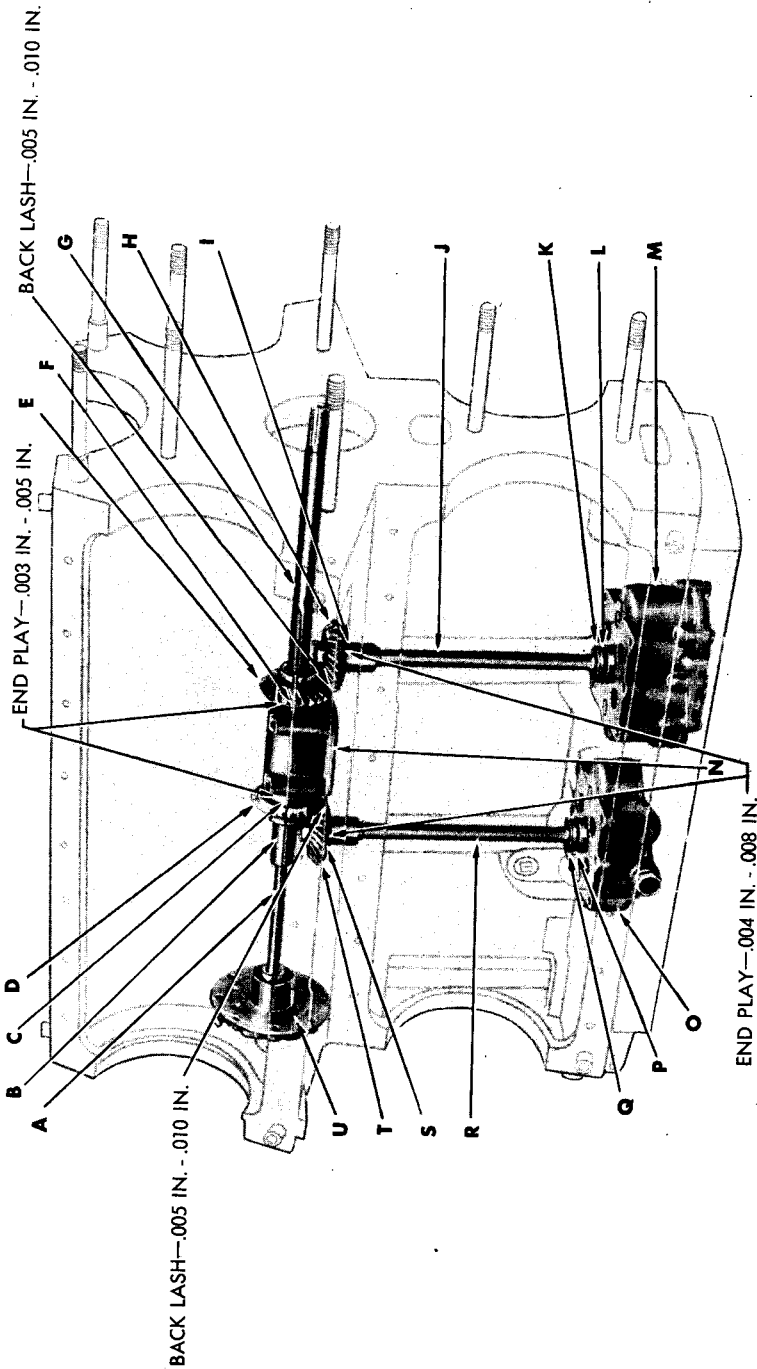
**(9) INSTALL CRANKCASE OIL Baffle AND CHECK PLUGS (fig. 140).**

**PLIERS**, side-cutting

**WRENCH**, socket,  $\frac{1}{2}$ -in.

Place baffle in position in crankcase (inside opening for No. 3 engine) and secure with 3 cap screws ( $\frac{1}{2}$ -in. socket wrench). Lock screws with lock wire (side cutting pliers). Make sure pipe plugs are in place, inside openings for engines Nos. 3 and 4.

ORDNANCE MAINTENANCE — POWER UNIT FOR  
MEDIUM TANKS M3A4 AND M4A4



RA PD 24317

Figure 137 — Accessory Drive Shaft, Fuel Pump Drive Assembly And Oil Pumps In Position In Crankcase

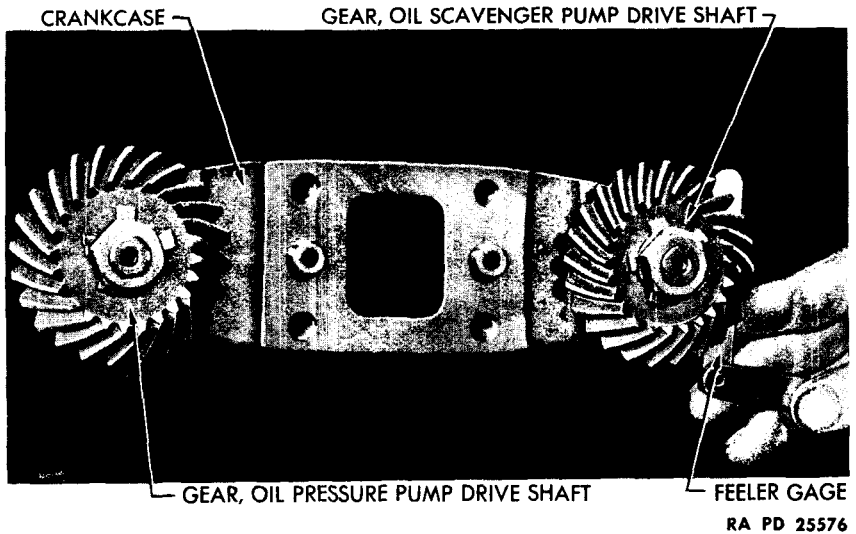
ASSEMBLY OF POWER UNIT

- A—SHAFT, DRIVE, FUEL PUMP
- B—SLEEVE, ACCESSORY DRIVE SHAFT
- C—WASHER, THRUST, ACCESSORY DRIVE SHAFT GEAR
- D—GEAR, ACCESSORY DRIVE SHAFT
- E—GEAR, ACCESSORY DRIVE SHAFT
- F—WASHER, THRUST, ACCESSORY DRIVE SHAFT GEAR
- G—SHAFT, DRIVE, ACCESSORY
- H—GEAR, OIL SCAVENGER PUMP DRIVE SHAFT
- I—WASHER, THRUST, OIL SCAVENGER PUMP DRIVE SHAFT GEAR
- J—SHAFT, DRIVE, OIL SCAVENGER PUMP
- K—WASHER, THRUST, OIL SCAVENGER PUMP DRIVE SHAFT
- L—WASHER, OIL SCAVENGER PUMP DRIVE SHAFT
- M—PUMP, SCAVENGER, OIL, ASSEMBLY
- N—SUPPORT, ACCESSORY DRIVE SHAFT
- O—PUMP, PRESSURE, OIL, ASSEMBLY
- P—WASHER, OIL PRESSURE PUMP DRIVE SHAFT
- Q—WASHER, THRUST, OIL PRESSURE PUMP DRIVE SHAFT
- R—SHAFT, DRIVE, OIL PRESSURE PUMP
- S—WASHER, THRUST, OIL PRESSURE PUMP DRIVE SHAFT GEAR
- T—GEAR, OIL PRESSURE PUMP DRIVE SHAFT
- U—DRIVE, FUEL PUMP, ASSEMBLY
- RA PD 243178

Legend For Figure 137 — Accessory Drive Shaft, Fuel Pump Drive Assembly And Oil Pumps In Position In Crankcase



ORDNANCE MAINTENANCE — POWER UNIT FOR  
MEDIUM TANKS M3A4 AND M4A4



**Figure 138 — Checking End Play In Oil Pump Drive Shafts**

(10) INSTALL NO. 5 ENGINE (fig. 141).

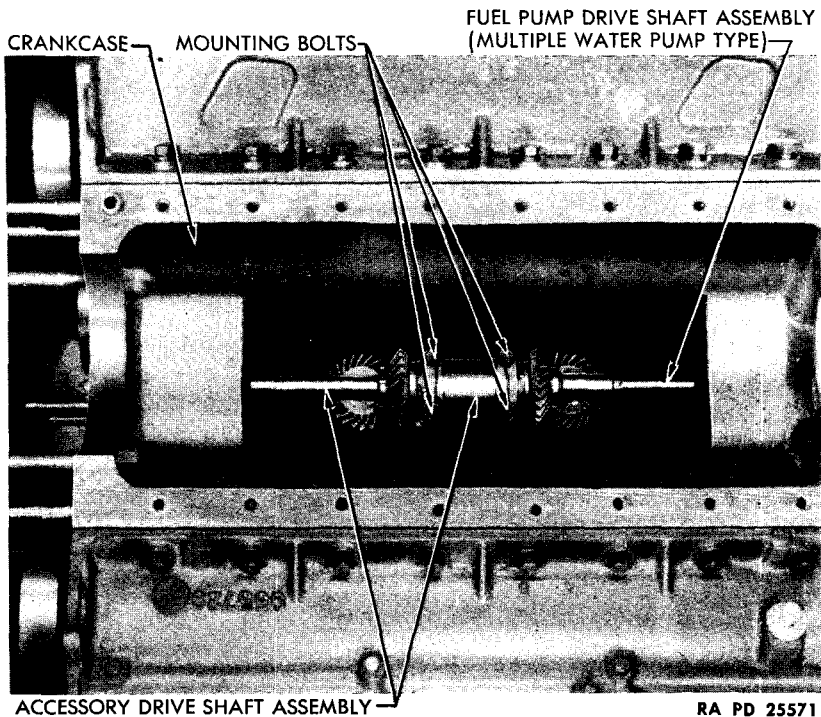
DRILL  
GAGE and INDICATOR, mas-  
ter drive gear

HAMMER, setting MTM-A4-  
19  
WRENCH, 5/8-in.  
WRENCH, torque

(a) Place crankcase on blocks, with opening for No. 5 engine up, and block crankcase in this position. Insert locating and oil supply dowel in opening in distributor end of crankcase. NOTE: Be sure this dowel fits snug in opening, as it serves as a connector tube to supply oil to the engine. Position new crankcase dowel gasket over dowel (fig. 140). Install locating dowel in opening in radiator end of crankcase (fig. 141).

(b) Place crankcase oil seal plate seal in position in distributor end of crankcase. This seal should be 10 5/8 inches long. Press seal (at each end) until seal is seated in bottom of opening. Hold seal in this position and drill one 1/8-inch hole, through seal and into crankcase, about 2 inches from each end of seal (drill). Drive a 0.090-inch nail through seal and into each hole in crankcase, to secure seal (hammer). It will be noted

## ASSEMBLY OF POWER UNIT



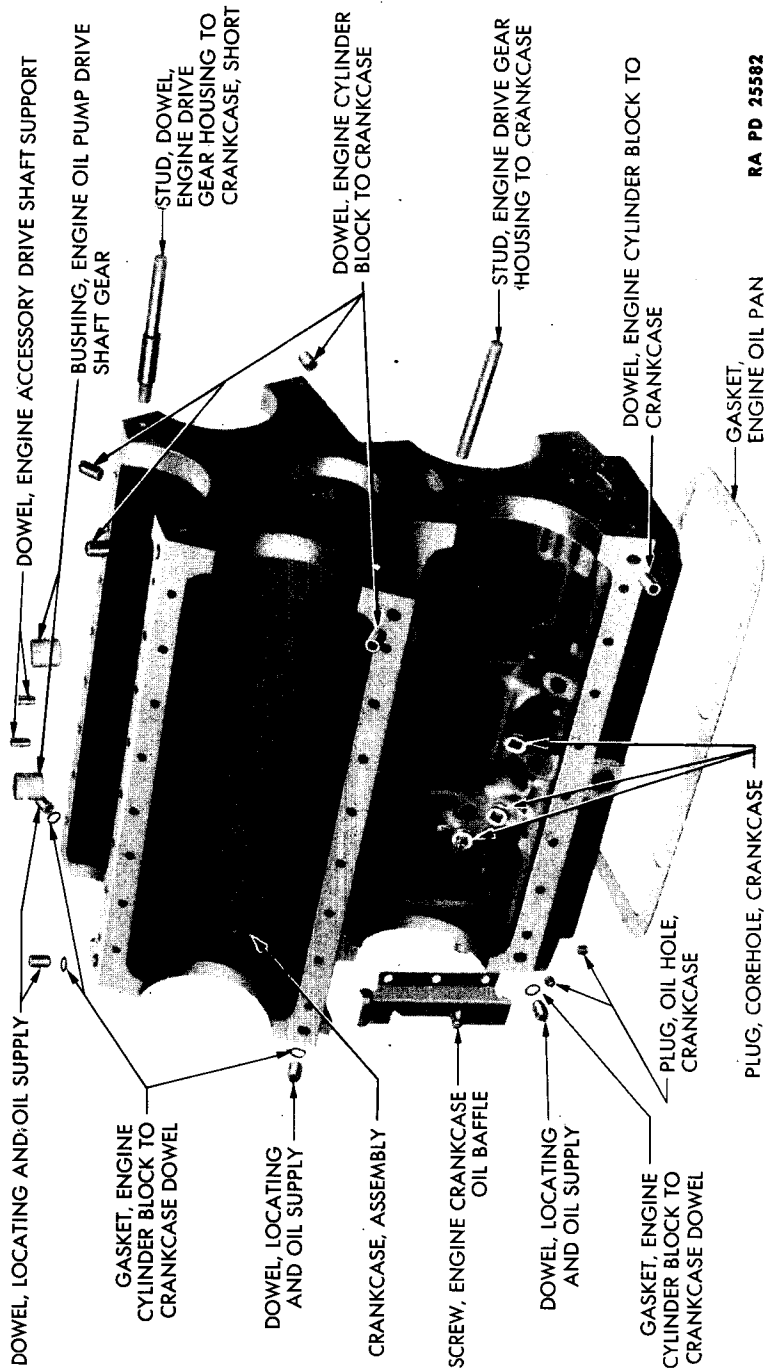
**Figure 139 — Accessory Drive Shaft In Position In Crankcase**

that when seal is in proper position the seal will extend slightly above the crankcase at each end. *Do not trim seal even with crankcase as this surplus is necessary for proper sealing.* Place cylinder block gaskets, both right and left, in position on crankcase. Select gaskets 0.010 inch thick. These gaskets are furnished in thickness 0.010-inch, indicated by one notch in outer edge of gasket; 0.015-inch, indicated by 2 notches in outer edge and 0.020 inch, indicated by 3 notches in outer edge of gasket.

(c) Raise engine with hoist and lower in place on crankcase. **NOTE:** If a new engine is being installed, be sure that opening in engine which contacts the locating and oil supply dowel is not obstructed. **CAUTION:** *When new engine assemblies are shipped, this opening is closed with a rubber plug. Be sure to remove this plug before installing engine, otherwise there will be no means of supplying oil to the engine, resulting in serious damage to the engine.* Start all cap screws which secure engine to crankcase and tighten screws at each corner of engine, to secure in place for checking.

(d) Place checking gage (fig. 142) in master (fig. 143) and adjust dial indicator until needle is at "O." Insert gage in opening in crankcase,

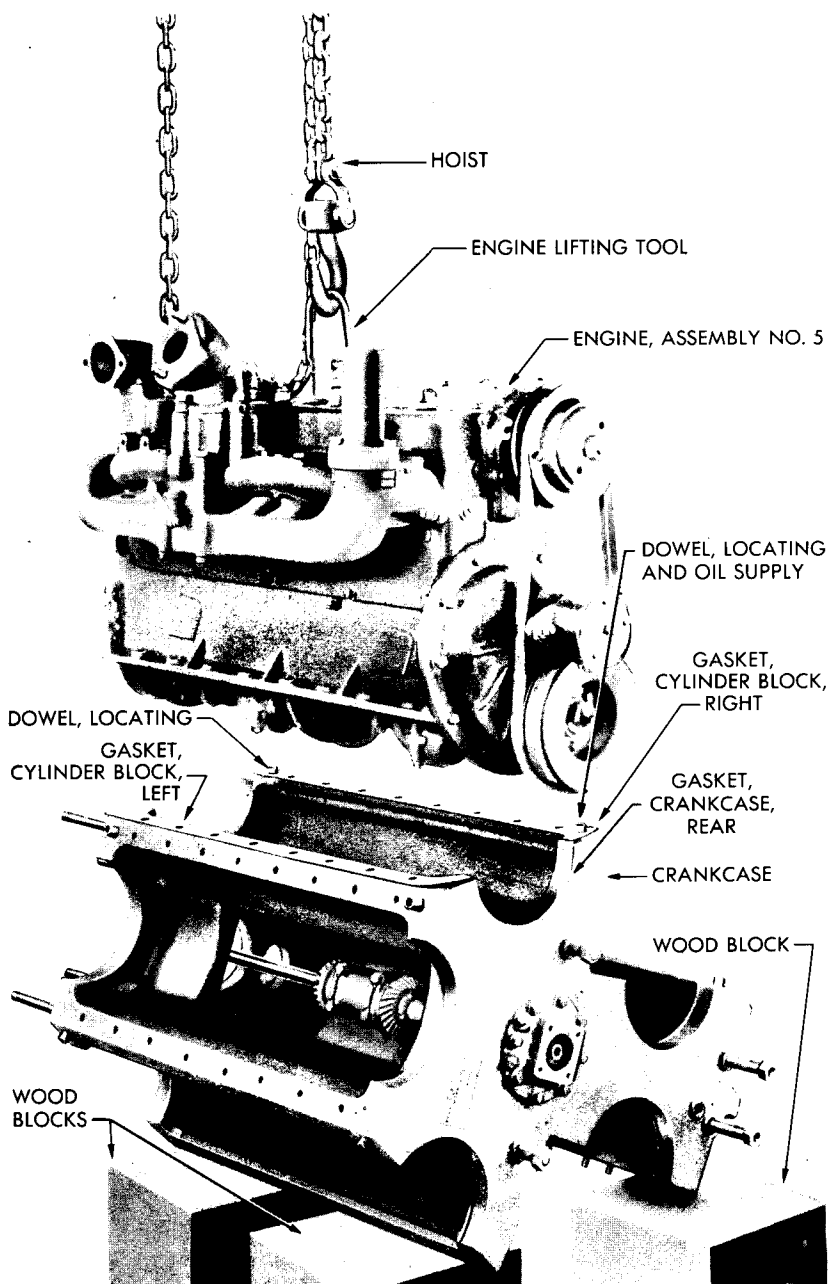
ORDNANCE MAINTENANCE — POWER UNIT FOR  
MEDIUM TANKS M3A4 AND M4A4



RA PD 25582

Figure 140 — Crankcase, Right Side And Radiator End, Exploded

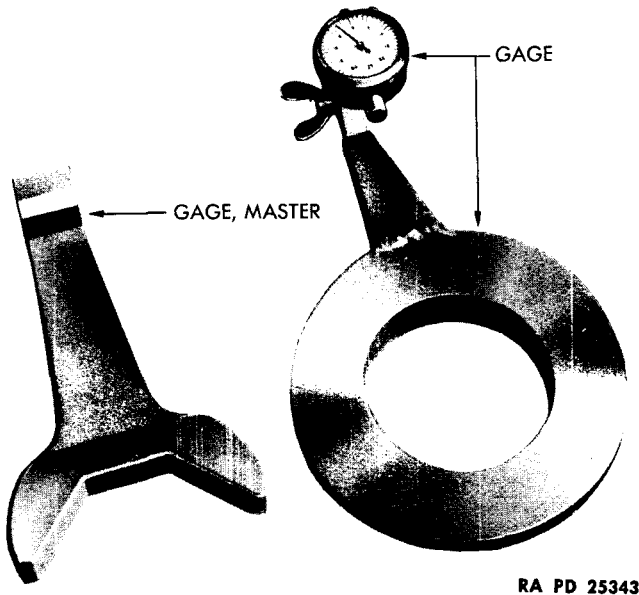
ASSEMBLY OF POWER UNIT



RA PD 25352

Figure 141 — Installing No. 5 Engine

**ORDNANCE MAINTENANCE — POWER UNIT FOR  
MEDIUM TANKS M3A4 AND M4A4**



RA PD 25343

**Figure 142 — Indicator And Master Gage Drive Gear Setting Gage**

with gage plunger contacting crankshaft flange (fig. 144). Rotate gage in crankcase opening to locate the lowest point on flange. When gage is set in master, with the needle at "O," the 0.004-inch limit allowed is divided. Change cylinder block gaskets, selecting gaskets of proper thickness, to obtain a zero reading on gage. **CAUTION:** Always use right and left gaskets of same thickness.

(e) When the correct reading is obtained, tighten all cap screws which secure engine to crankcase to 40 to 45 foot pounds ( $\frac{5}{8}$ -in. wrench and torque wrench).

**(11) INSTALL No. 4 ENGINE (fig. 145).**

**HOIST**

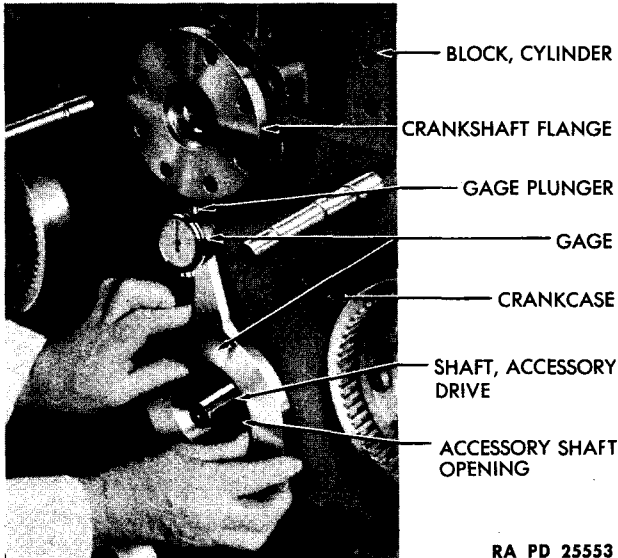
Lift No. 5 engine and crankcase assembly with hoist and locate, on blocks, with opening for No. 4 engine up, (fig. 145). Follow same procedure as outlined in the installation of No. 5 engine with the exception of the installation of the cap screws which secure engine to crankcase. Do not install the cap screw, on left side of engine at radiator end. It is necessary to leave this cap screw out until after the drive gear case is installed, to provide room for the long wrench which is shown in figure 145. (This wrench is shown in this illustration to assist in the use of the wrench when installing the gear case, and is not necessary in lowering

ASSEMBLY OF POWER UNIT



RA PD 25344

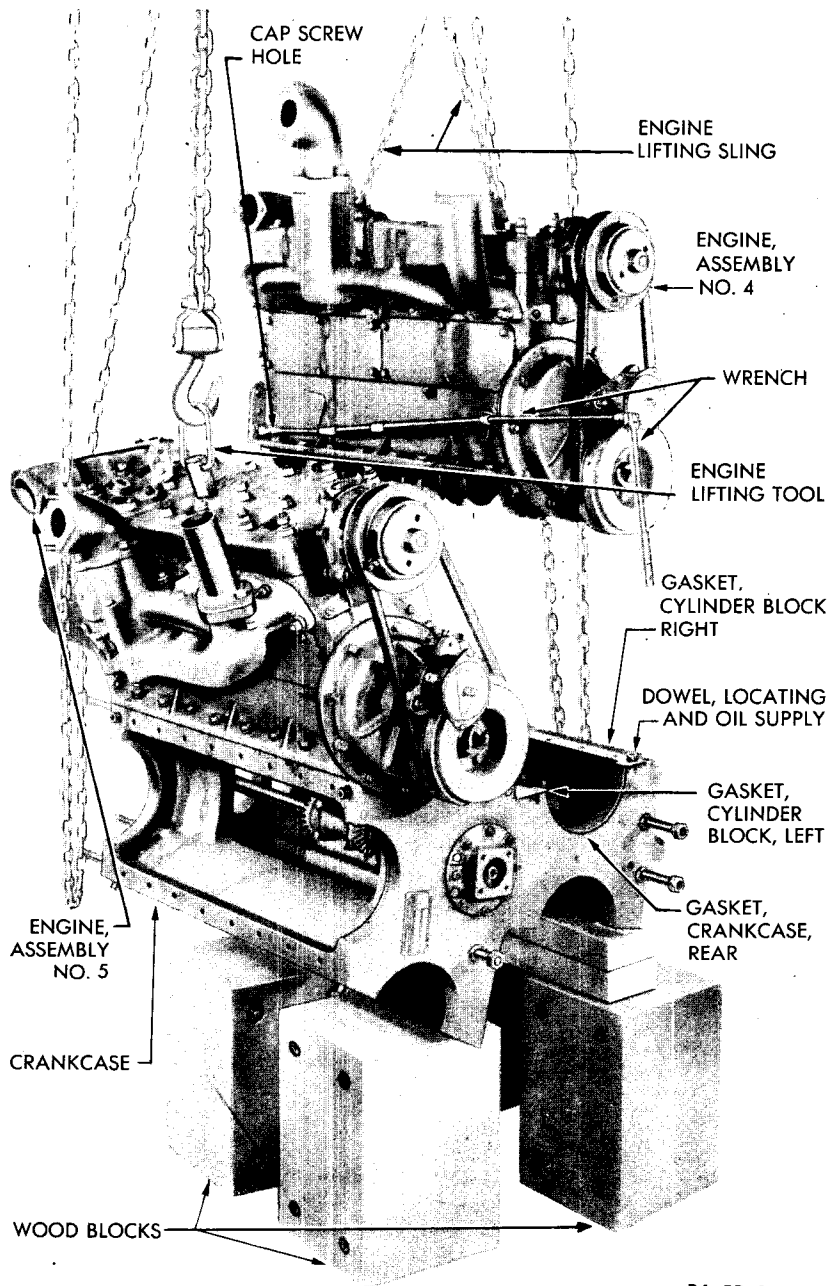
Figure 143 — Setting Gage In Master



RA PD 25553

Figure 144 — Measuring Distance From Crankcase Opening To Crankshaft Flange

ORDNANCE MAINTENANCE — POWER UNIT FOR  
MEDIUM TANKS M3A4 AND M4A4



RA PD 25350

Figure 145 — Installing No. 4 Engine

**ASSEMBLY OF POWER UNIT**

the engine to the crankcase.) **CAUTION:** Be sure that the locating and oil supply dowel is free of obstructions and that the corresponding opening in the engine is also free of obstructions.

**(12) INSTALL OIL PUMPS (fig. 148).**

- |  |   |
|--|---|
| <b>PLIERS</b> , side-cutting                 | <b>WRENCH</b> , pipe, 16-in.                |
| <b>SCREWDRIVER</b>                           | <b>WRENCH</b> , socket, $\frac{9}{16}$ -in. |
| <b>WRENCH</b> , open-end, $\frac{5}{8}$ -in. | <b>WRENCH</b> , torque                      |
| <b>WRENCH</b> , open-end, 1-in.              |   |

(a) Position new gasket on left side of crankcase and place crankcase oil filter pad cover in position. Insert the 2 short attaching bolts, from inside crankcase, and secure cover with bolts ( $\frac{5}{8}$ -in. open-end wrench). Position new gasket and scavenger pump outlet elbow on crankcase, insert 2 long attaching bolts, from inside crankcase, and attach elbow to crankcase ( $\frac{5}{8}$ -in. open-end wrench). Lock bolts with locking wires (side-cutting pliers).

(b) Position new gasket on pressure oil pump and secure in crankcase, at distributor end, with 6 cap screws ( $\frac{9}{16}$ -in. socket wrench). Tighten cap screws to 30 to 35 foot pounds. Position new gasket on scavenger oil pump and attach scavenger pump to crankcase, at radiator end, securing with 6 cap screws and lock washers ( $\frac{9}{16}$ -in. socket wrench). Tighten cap screws to 30 to 35 foot pounds. Lock all cap screws with locking wires (side-cutting pliers). Install tee in scavenger pump outlet elbow (pipe wrench). Install oil temperature gage sending unit in tee (1-in. open-end wrench) (fig. 146). Check strainer in oil pan. Be sure all cap screws are securely in place. Position new gasket on oil pan and attach pan to crankcase with cap screws. Before installing all cap screws, connect engine to oil cooler tube to tee (1-in. open-end wrench) and secure to oil pan with 3 clips (fig. 147). Tighten cap screws securely and lock in place with locking wires (side-cutting pliers).

**(13) INSTALL NO. 3 ENGINE.**

Place assembly in position as shown in figure 148 and follow the procedure outlined for installation of No. 5 engine. **CAUTION:** Be sure that openings in locating and oil supply dowel, and corresponding opening in engine, are free from obstructions.

**(14) INSTALL NO. 2 ENGINE.**

Place assembly in position as shown in figure 149 and follow procedure outlined for installation of No. 5 engine. **CAUTION:** Be sure that openings in locating and oil supply dowel, and corresponding opening in engine are free from obstructions.



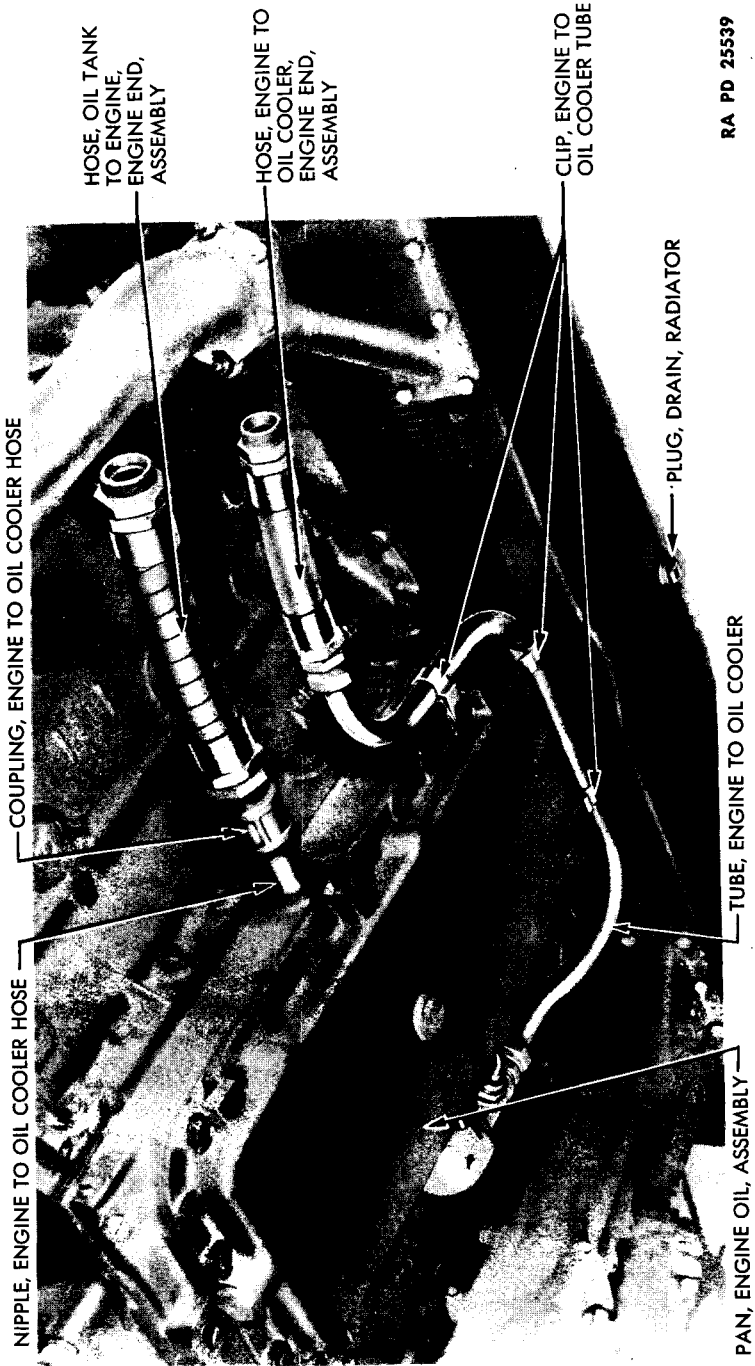
ORDNANCE MAINTENANCE – POWER UNIT FOR  
MEDIUM TANKS M3A4 AND M4A4



RA PD 25540

Figure 146 — Power Unit Oil Tubes, Bottom And Left Side

ASSEMBLY OF POWER UNIT



RA PD 25539

Figure 147 — Power Unit Oil Tubes, Bottom And Right Side

ORDNANCE MAINTENANCE — POWER UNIT FOR  
MEDIUM TANKS M3A4 AND M4A4

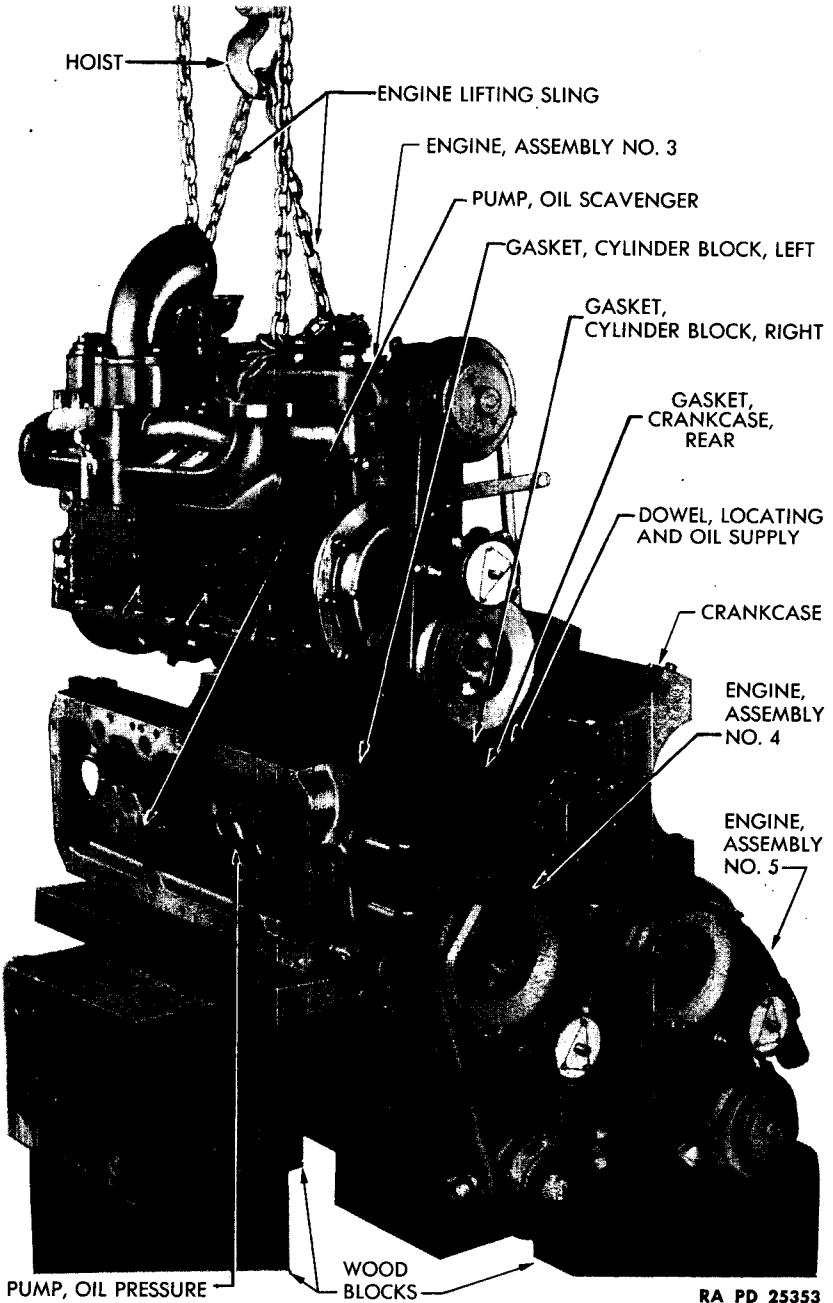
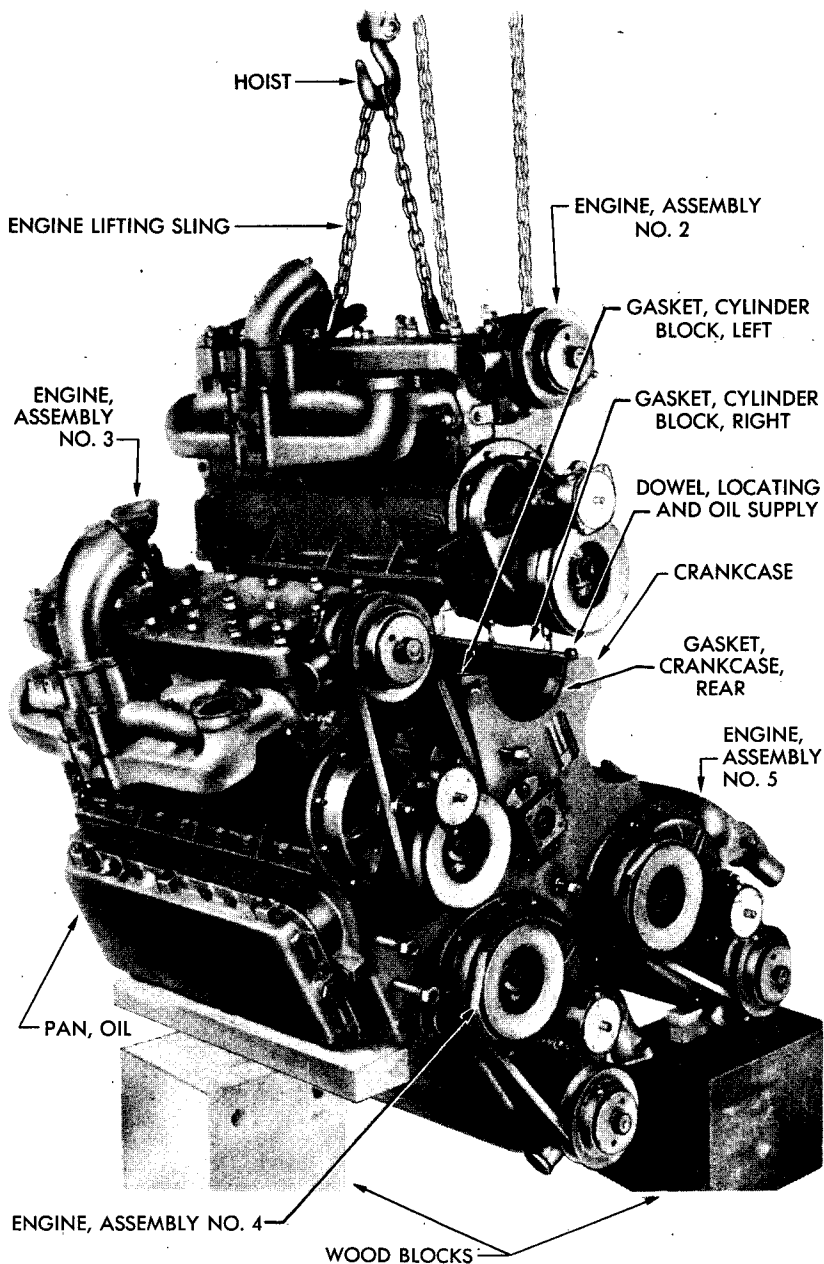


Figure 148 — Installing No. 3 Engine

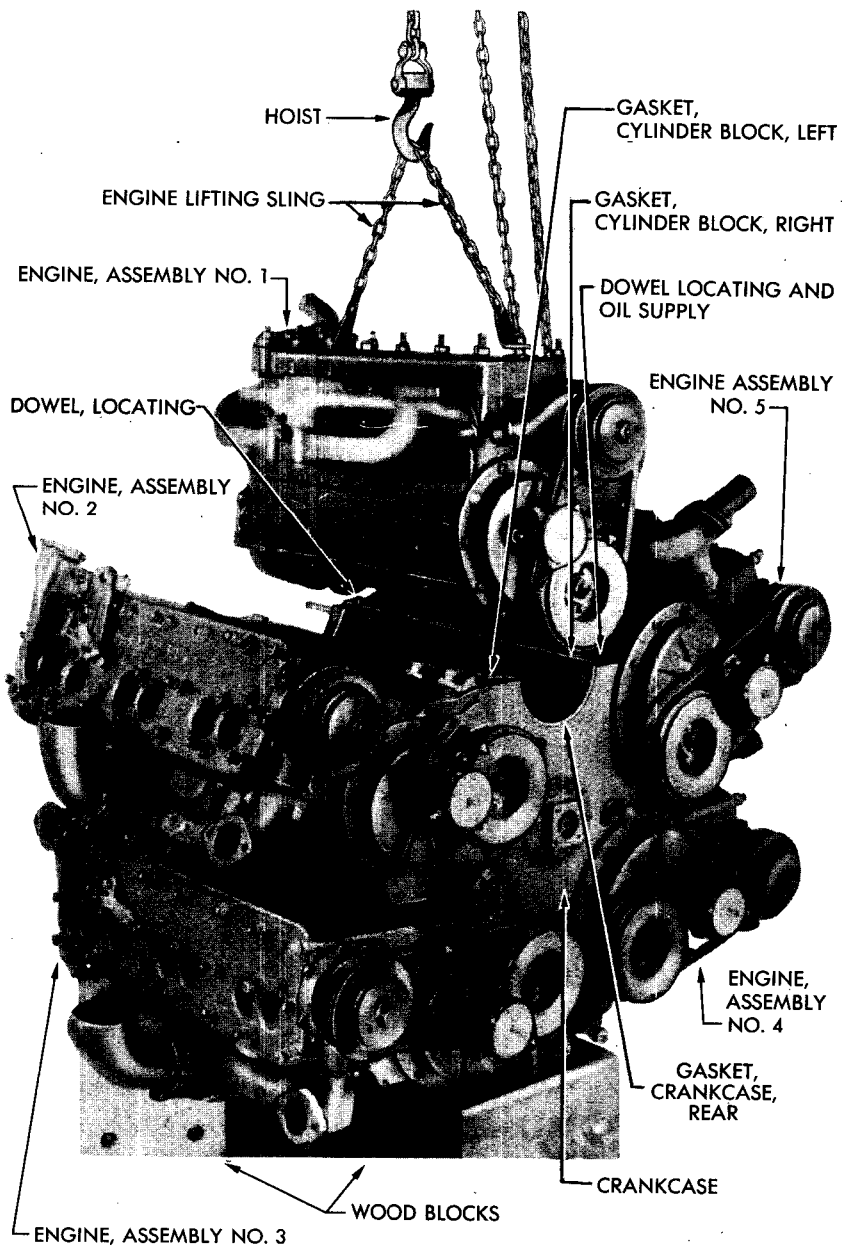
ASSEMBLY OF POWER UNIT



RA PD 25357

Figure 149 — Installing No. 2 Engine

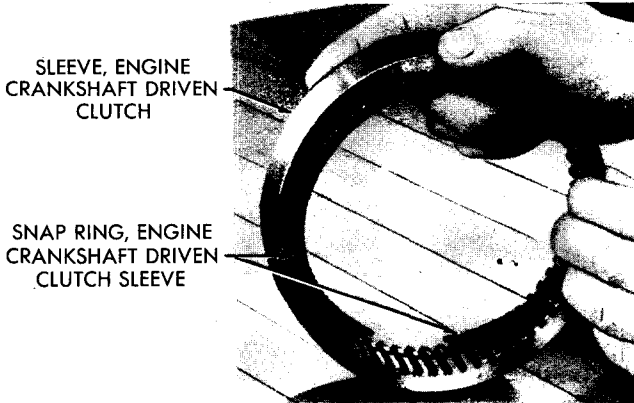
ORDNANCE MAINTENANCE — POWER UNIT FOR  
MEDIUM TANKS M3A4 AND M4A4



RA PD 25347

Figure 150 — Installing No. 1 Engine

**ASSEMBLY OF POWER UNIT**



RA PD 25500

**Figure 151 – Installing Snap Ring In Clutch Sleeve**

**(15) INSTALL NO. 1 ENGINE.**

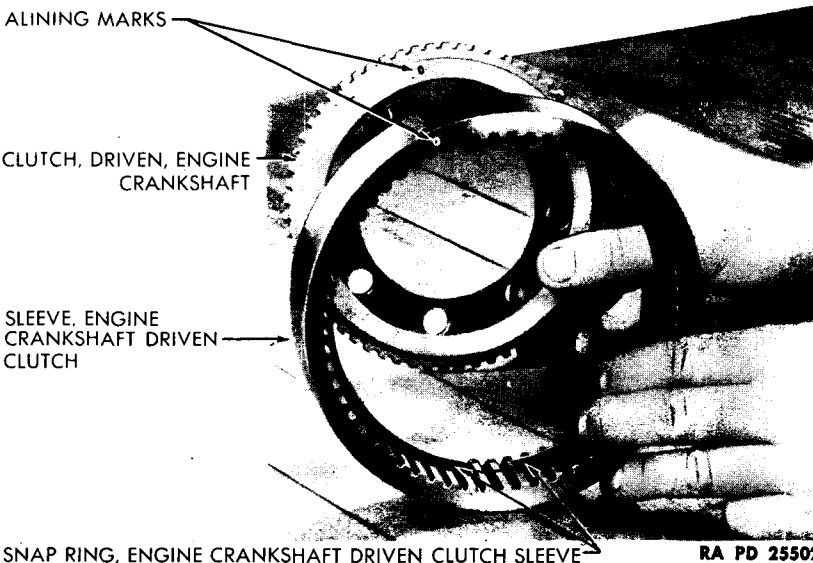
Place assembly in position as shown in figure 150 and follow procedure outlined for installation of No. 5 engine. **CAUTION:** Be sure that openings in locating and oil supply dowel, and corresponding opening in engine are free from obstructions.

**(16) INSTALL CRANKSHAFT DRIVEN CLUTCH AND SLEEVE.**

**WRENCH**, socket, 5/8-in.

**WRENCH**, torque

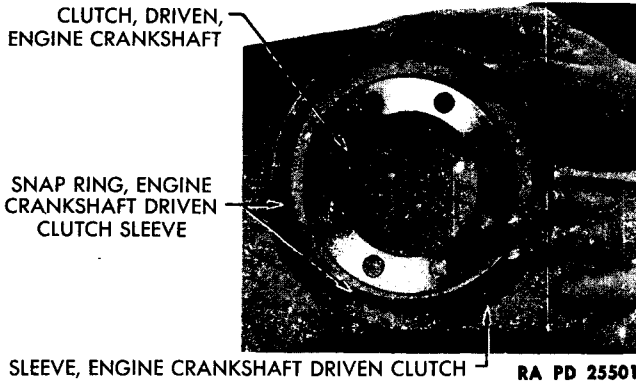
Place engine crankshaft driven clutch sleeve snap ring in inside groove



RA PD 25502

**Figure 152 – Installing Engine Crankshaft Driven Clutch In Sleeve**

**ORDNANCE MAINTENANCE — POWER UNIT FOR  
MEDIUM TANKS M3A4 AND M4A4**



**Figure 153 — Installing Snap Ring In Engine Crankshaft  
Driven Clutch Sleeve**

of sleeve (fig. 151). Align the zeros on clutch and sleeve, as shown in figure 152, and assemble clutch to sleeve. Install snap ring in outer groove of sleeve (fig. 153). Install clutch and sleeve assembly on crankshaft flange (fig. 154). **NOTE:** Holes in crankshaft flange and clutch are unevenly spaced, to simplify installations. Insert attaching bolts, placing bolts in position so nuts are toward engine. Tighten bolts to 55 to 60 foot pounds ( $\frac{5}{8}$ -in. socket wrench). Repeat operation to install clutch and sleeve on the other 4 engines (fig. 115). Check to be sure that oil distributor plugs in engines Nos. 1, 2, and 5 have  $\frac{3}{32}$ -inch hole in center of plug, to supply oil to drive gear housing.

**(17) SYNCHRONIZE ENGINES.**

**INDICATOR,** timing

**WRENCH,**  $\frac{1}{2}$ -in.

(a) Remove brass plug from cylinder head of each engine, directly above No. 1 cylinder ( $\frac{1}{2}$ -in. wrench) (fig. 107). Insert timing indicator in this opening and set engines, Nos. 1, 3, and 5, on top dead center, with No. 1 cylinder in firing position. Set engines, Nos. 2 and 4 on top dead center, with No. 6 cylinder in firing position.

(b) Leave No. 1 engine in this position.

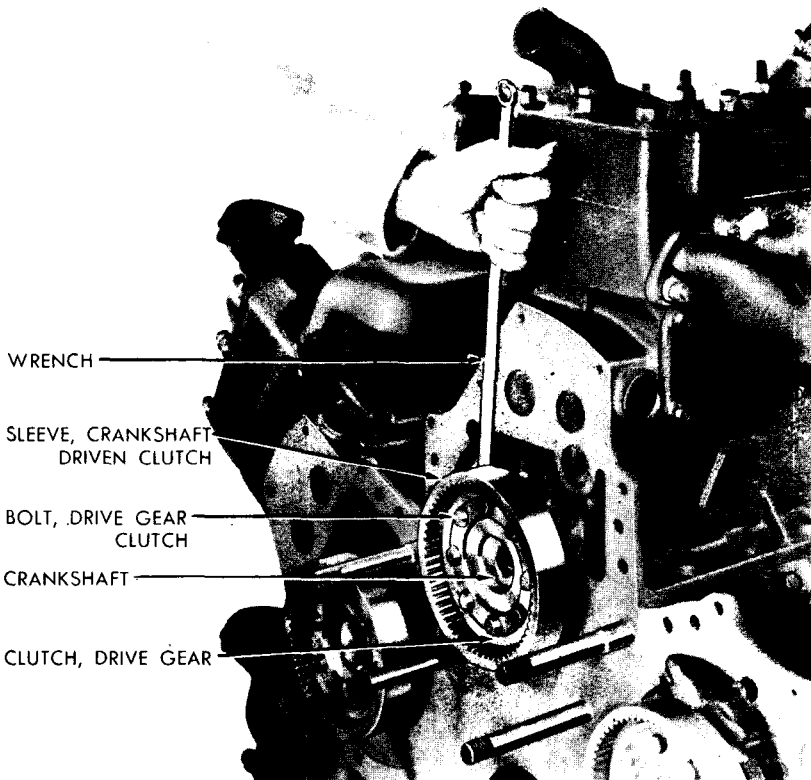
(c) Rotate No. 2 engine clockwise, as viewed from distributor end of engine, 72 degrees.

(d) Rotate No. 3 engine clockwise, 144 degrees.

(e) Rotate No. 4 engine clockwise, 216 degrees.

(f) Rotate No. 5 engine clockwise, 288 degrees.

ASSEMBLY OF POWER UNIT



RA PD 25356

**Figure 154 – Installing Clutch And Sleeve Assembly On Crankshaft**

(g) With all engines set in the above position, they will be synchronized to fire 24 degrees between each power impulse (fig. 156), and the engine drive gear housing can be installed. Install brass plugs in distributor end of each engine cylinder head.

(18) **INSTALL ENGINE DRIVEN GEAR AND SHAFT IN HOUSING (fig. 157).**

**CAN, oil**

**DRIFT**

**DRIVER, main drive shaft  
front bearing installing,  
MTM-A4-14**

**DRIVER, gear box main drive  
gear and bearing  
MTM-A4-45**

**HAMMER, steel**

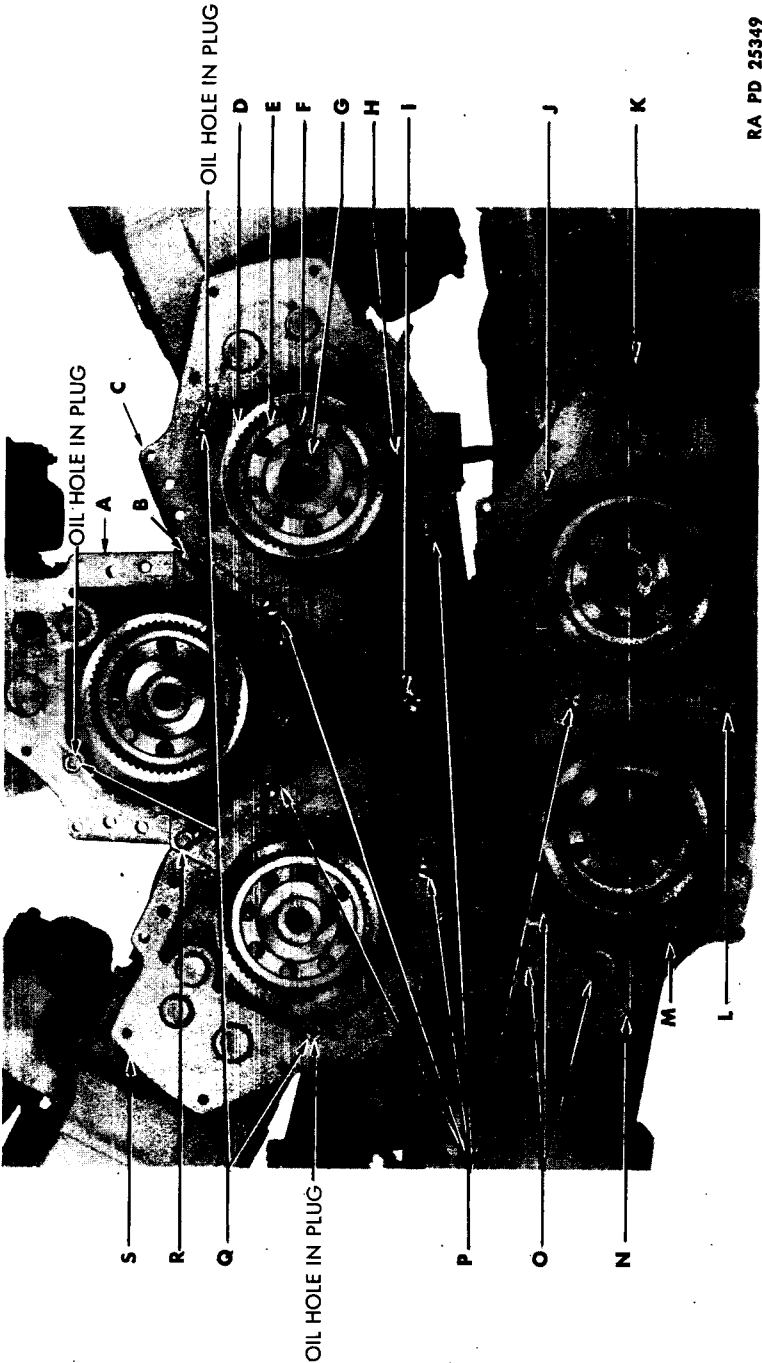
**PLATE, MTM-A4-38**

**WRENCH, bull shaft bearing  
lock nut, MTM-A4-1**

**WRENCH, spanner**



ORDNANCE MAINTENANCE — POWER UNIT FOR  
MEDIUM TANKS M3A4 AND M4A4



RA PD 25349

Figure 155 — Radiator End Of Power Unit Less Drive Gear Housing

## ASSEMBLY OF POWER UNIT

- A—BLOCK, CYLINDER, ASSEMBLY (NO. 1 ENGINE)
- B—STUD, DOWEL, ENGINE DRIVE GEAR HOUSING TO CRANKCASE, SHORT
- C—BLOCK, CYLINDER, ASSEMBLY (NO. 2 ENGINE)
- D—SLEEVE, CRANKSHAFT DRIVEN CLUTCH
- E—CLUTCH, CRANKSHAFT DRIVEN
- F—BOLT, CRANKSHAFT DRIVEN CLUTCH
- G—CRANKSHAFT
- H—CRANKCASE, ASSEMBLY
- I—SHAFT, ACCESSORY DRIVE, ASSEMBLY
- J—PLUG, OIL DISTRIBUTOR TUBE (NO. 3 ENGINE)
- K—BLOCK, CYLINDER, ASSEMBLY (NO. 3 ENGINE)
- L—STUD, DOWEL, ENGINE DRIVE GEAR HOUSING TO CRANKCASE, SHORT
- M—PLUG, OIL DISTRIBUTOR TUBE (NO. 4 ENGINE)
- N—BLOCK, CYLINDER, ASSEMBLY (NO. 4 ENGINE)
- O—PLUG, EXPANSION
- P—STUD, ENGINE DRIVE GEAR HOUSING TO CRANKCASE
- Q—PLUG, OIL DISTRIBUTOR, FRONT (NOS. 1, 2, 5 ENGINES)
- R—STUD, DOWEL, ENGINE DRIVE GEAR HOUSING TO CRANKCASE, SHORT
- S—BLOCK, CYLINDER, ASSEMBLY (NO. 5 ENGINE)

RA PD 25349B

**Legend For Figure 155 — Radiator End Of Power Unit Less Drive Gear Housing**

ORDNANCE MAINTENANCE — POWER UNIT FOR  
MEDIUM TANKS M3A4 AND M4A4

(a) Lay the drive gear housing flat (with gear side down). Oil engine driven gear shaft outer bearing thoroughly and insert in opening in center of housing (fig. 158). Drive bearing into housing with bearing driver MTM-A4-14 (fig. 159). Install bearing retaining plate MTM-A4-38 and secure with the 6 cap screws to support the bearing on its inner face while installing the shaft and gear (fig. 160).

(b) Turn gear housing over and support on blocks in such manner that shaft will extend through opening between blocks when installed in housing. Cover driven gear shaft with oil and install in opening in housing, driving it into position with driver MTM-A4-45. Oil the driven gear shaft inner bearing and shaft and install bearing on shaft, driving it into position with driver MTM-A4-45 (fig. 161). Install the 2 keys in keyways in the shaft, making certain they are both seated properly in keyways. Heat the driven gear with some uniform heating device (as a bank of electric lights or electric oven to 250 F). CAUTION: Do not use an open flame to heat this gear. Install the driven gear on shaft and drive into position with driver MTM-A4-45 (fig. 162). Rotate the gear and shaft while the gear is being driven on, to prevent brinnelling of the bearings. Install the driven gear lock nut lock washer and nut (wrench MTM-A4-1). Tighten nut securely and lock in place by using a hammer and drift to bend tabs of lock nut lock washer into recesses in nut (figs. 163, 164, 165, and 166).

(19) ASSEMBLE ENGINE DRIVE GEAR.

PRESS, arbor

WRENCH, socket,  $\frac{9}{16}$ -in.

SCREWDRIVER

Make certain the 2 bearings are clean and free of all foreign matter. Remove all dirt from opening in hub of gear (fig. 167). Oil bearing and insert in opening in gear, pressing into position with arbor press (fig. 168). Insert snap ring in opening in gear, forcing into groove with screwdriver. Turn gear over, and press spacer into position with arbor press. Insert snap ring in opening in gear, forcing into groove with screwdriver (fig. 169). Install engine drive gear clutch on drive gear and secure with 8 bolts and nuts ( $\frac{9}{16}$ -in. socket wrench) (fig. 170). NOTE: Install clutch on gear with "O," located near outer periphery of clutch, facing drive gear. The clutch mounting holes are unevenly spaced to simplify installation (fig. 170). Repeat above operations to assemble the other 4 gears.

(20) INSTALL ENGINE DRIVE GEARS.

CAN, oil

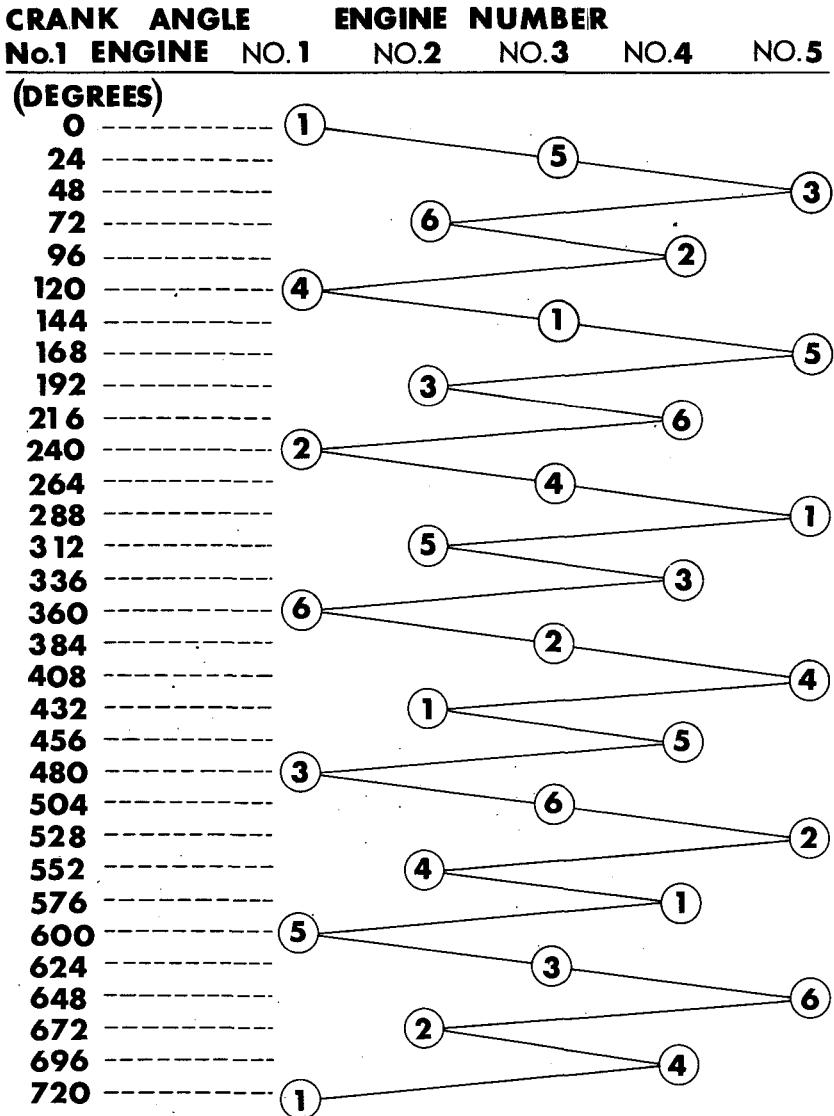
TOOL, drive gear alining,

DRIVER, drive gear stub,

MTM-A4-39

MTM-A4-43

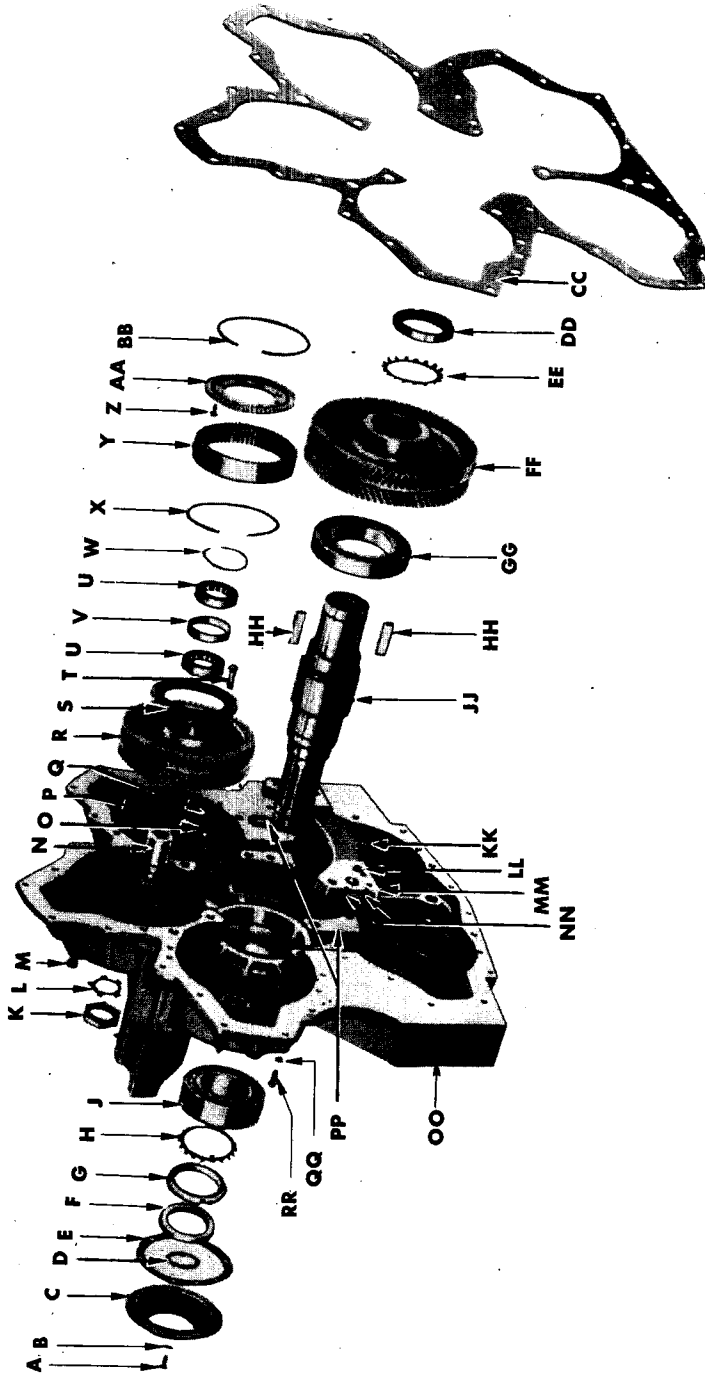
ASSEMBLY OF POWER UNIT



RA PD 25249

Figure 156 — Firing Order Of Power Unit

ORDNANCE MAINTENANCE — POWER UNIT FOR  
MEDIUM TANKS M3A4 AND M4A4



RA PD 24526

Figure 157 — Engine Drive Gear Housing, Exploded

ASSEMBLY OF POWER UNIT

- A—SCREW, RETAINER, DRIVEN GEAR SHAFT OIL SEAL
- B—WASHER, LOCK, DRIVEN GEAR SHAFT OIL SEAL RETAINER SCREW
- C—RETAINER, OIL SEAL, DRIVEN GEAR SHAFT
- D—GASKET, OIL SEAL, DRIVEN GEAR SHAFT
- E—GASKET, RETAINER, DRIVEN GEAR SHAFT OIL SEAL
- F—SEAL, OIL, DRIVEN GEAR SHAFT
- G—NUT, RETAINER, DRIVEN GEAR SHAFT OUTER BEARING
- H—WASHER, LOCK, DRIVEN GEAR SHAFT OUTER BEARING  
RETAINER NUT
- J—BEARING, DRIVEN GEAR SHAFT, OUTER
- K—NUT, LOCK, DRIVE GEAR SHAFT
- L—WASHER, LOCK, DRIVE GEAR SHAFT LOCK NUT
- M—PLUG, TIMING HOLE, DRIVE GEAR HOUSING
- N—SHAFT, DRIVE GEAR
- O—NUT, DRIVE GEAR CLUTCH BOLT
- P—RING, SNAP, DRIVE GEAR BEARING
- Q—WASHER, LOCK, DRIVE GEAR CLUTCH BOLT NUT
- R—GEAR, DRIVE
- S—CLUTCH, DRIVE GEAR
- T—BOLT, DRIVE GEAR CLUTCH
- U—BEARING, DRIVE GEAR
- V—SPACER, BEARING, DRIVE GEAR
- W—RING, SNAP, DRIVE GEAR BEARING
- X—RING, SNAP, CRANKSHAFT DRIVEN CLUTCH SLEEVE
- Y—SLEEVE, CRANKSHAFT DRIVEN CLUTCH
- Z—BOLT, CRANKSHAFT DRIVEN CLUTCH
- AA—CLUTCH, DRIVEN, CRANKSHAFT
- BB—RING, SNAP, CRANKSHAFT DRIVEN CLUTCH SLEEVE
- CC—GASKET, DRIVE GEAR HOUSING
- DD—NUT, LOCK, DRIVEN GEAR
- EE—WASHER, LOCK, DRIVEN GEAR LOCK NUT
- FF—GEAR, DRIVEN
- GG—BEARING, DRIVEN GEAR SHAFT, INNER
- HH—KEY, DRIVEN GEAR
- JJ—SHAFT, DRIVEN GEAR
- KK—SCREW, SEAL PLATE, DRIVE GEAR HOUSING
- LL—WASHER, LOCK, DRIVE GEAR HOUSING SEAL PLATE SCREW
- MM—PLATE, SEAL, DRIVE GEAR HOUSING
- NN—SEAL, OIL, DRIVE GEAR HOUSING SEAL PLATE
- OO—HOUSING, DRIVE GEAR, ASSEMBLY
- PP—GASKET, SEAL PLATE, DRIVE GEAR HOUSING
- QQ—WASHER, LOCK, DRIVE GEAR HOUSING TO CYLINDER  
BLOCK SCREW
- RR—SCREW, DRIVE GEAR HOUSING TO CYLINDER BLOCK

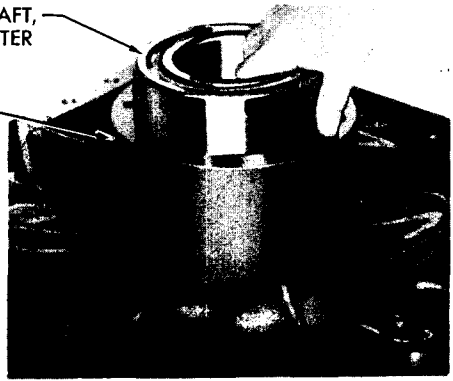
RA PD 245268

Legend For Figure 157 — Engine Drive Gear Housing, Exploded

**ORDNANCE MAINTENANCE – POWER UNIT FOR  
MEDIUM TANKS M3A4 AND M4A4**

BEARING, ENGINE DRIVEN GEAR SHAFT,  
OUTER

HOUSING, ENGINE POWER UNIT  
DRIVE GEAR

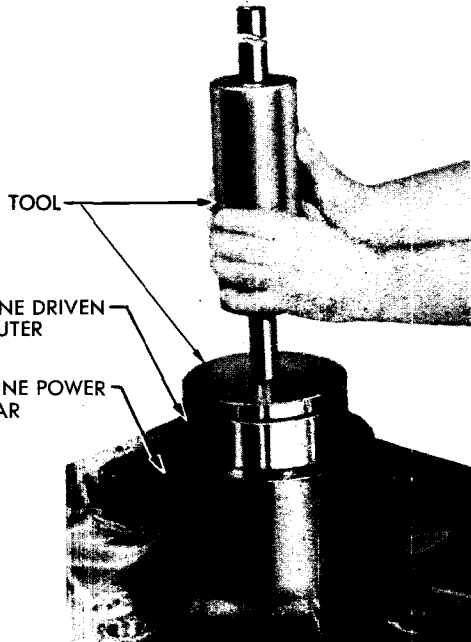


RA PD 25484

**Figure 158 – Installing Engine Driven Gear Shaft Outer Bearing**

(a) Install the No. 1 engine drive gear in housing and mesh with the driven gear, indexing the numerals "1" on both the drive gear and driven gear (fig. 177).

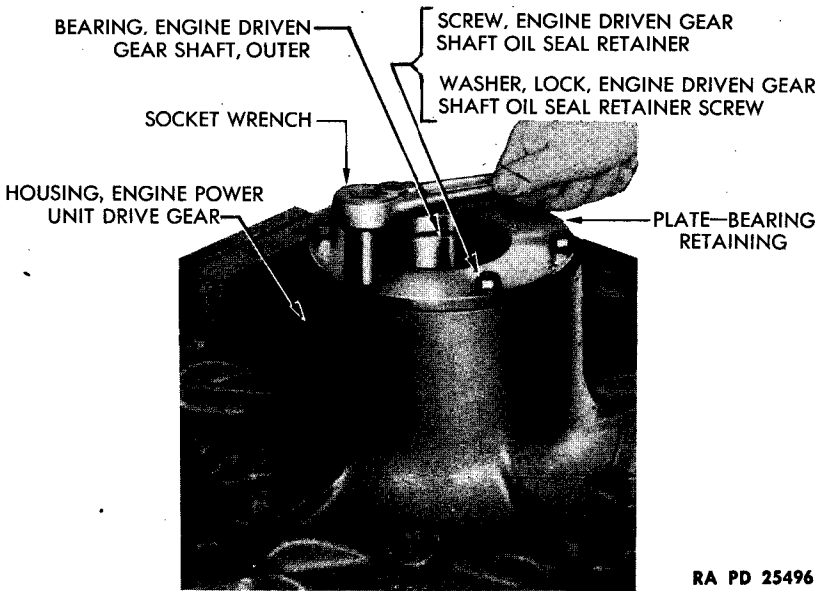
(b) Mount the alining tool MTM-A4-39 on housing. Insert the 2



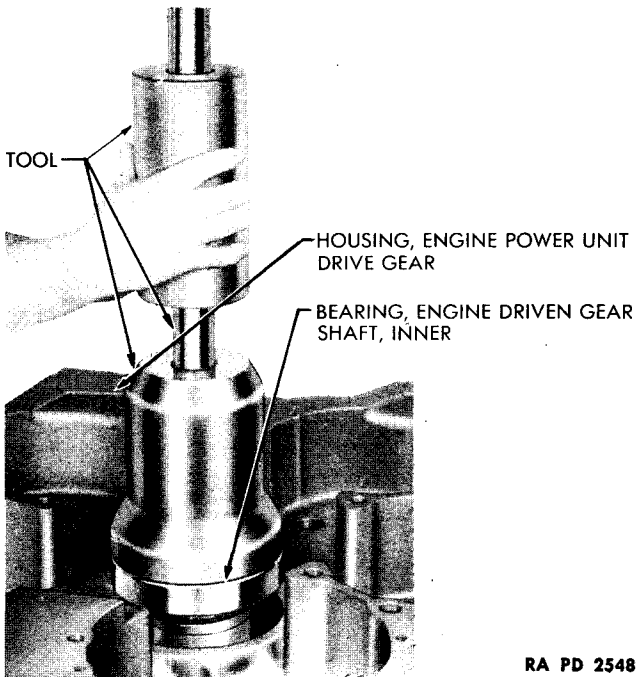
RA PD 25488

**Figure 159 – Installing Engine Driven Gear Shaft Outer Bearing**

**ASSEMBLY OF POWER UNIT**



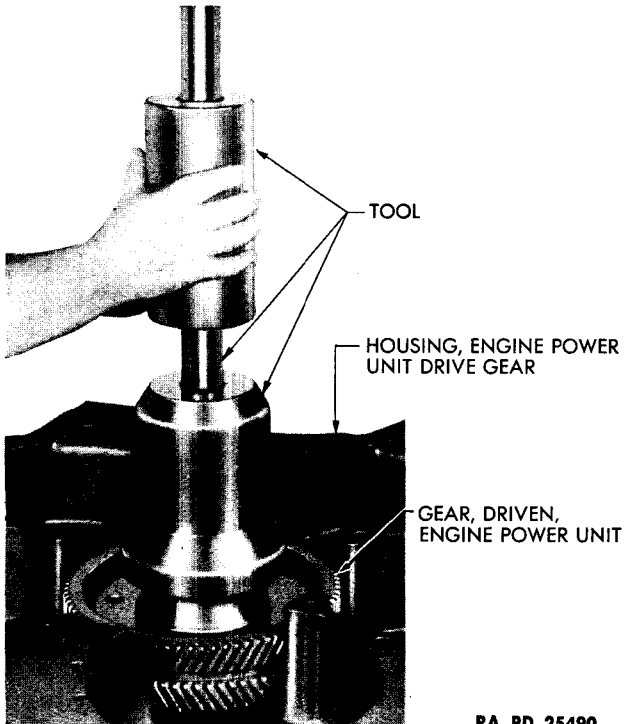
**Figure 160 – Bearing Retaining Plate In Position To Support Bearing**



**Figure 161 – Driving Engine Driven Gear Shaft Inner Bearing Into Position In Housing**



**ORDNANCE MAINTENANCE — POWER UNIT FOR  
MEDIUM TANKS M3A4 AND M4A4**



RA PD 25490

**Figure 162 — Installing Driven Gear On Shaft**

fingers of the alining tool through the holes in the gear, and tighten the 2 small knurled nuts to secure the gear to the alining tool (fig. 171).

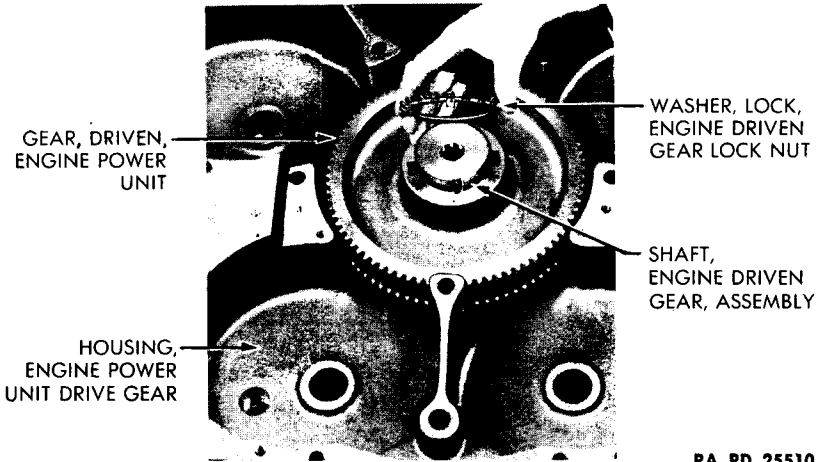
(c) Insert shaft plug alining tool in opening in hub gear. Turn the large knurled nut until the plug is free to move up and down. This alines the gear with the shaft hole in the housing (fig. 172). Remove the plug alining tool, select the correct shaft (as indicated by prick punch marks), lubricate shaft and insert in hub of gear (fig. 173). Drive shaft into position with driver MTM-A4-43 (fig. 174). Always rotate the gear while the shaft is being driven into position. Repeat the above operations to install the other 4 gears, making sure that each drive gear number indexes with its corresponding number on the driven gear. (1 and 1, 2 and 2, 3 and 3, 4 and 4, 5 and 5 (fig. 177).

(21) **INSTALL ENGINE DRIVE GEAR HOUSING SEAL PLATE** (figs. 175 and 176).

**WRENCH**, socket,  $\frac{7}{8}$ -in.

Install 4 new engine drive gear seal plate rubber oil seals in the grooves in the seal plate. Position new engine drive gear housing seal plate gaskets

ASSEMBLY OF POWER UNIT



RA PD 25510

Figure 163 — Placing Engine Driven Gear Lock Nut Lock Washer In Position

in recesses in housing to receive plate, making sure they fit tight in the corners of the recesses (fig. 175). Install plate in housing, securing with 2 cap screws and lock washers. **CAUTION:** Make sure that the ends of the rubber oil seals extend out of the grooves in the plate, so as to form a seal with the gaskets (figs. 176 and 177).

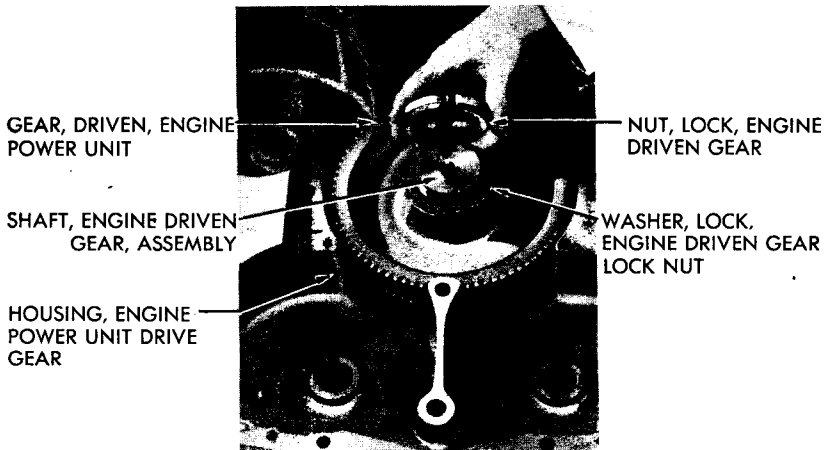
(22) SECURE ENGINE DRIVE GEAR SHAFTS IN HOUSING.

DRIFT

WRENCH, socket, 2 1/8-in.

HAMMER, steel

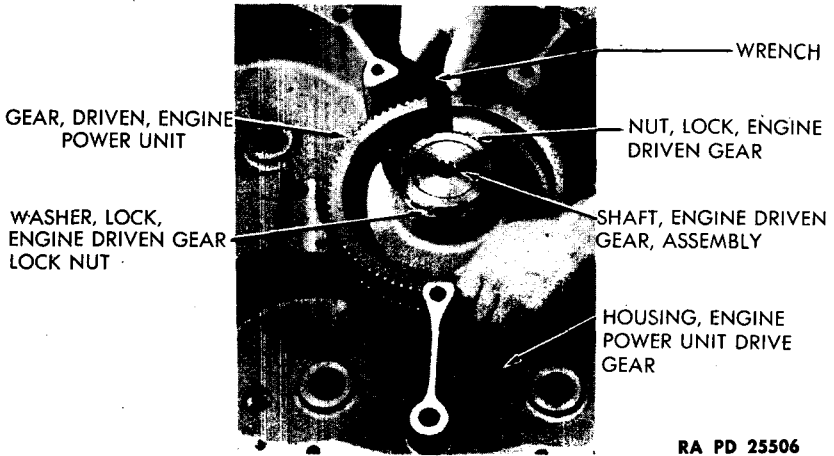
Turn drive gear housing assembly over (with gear side down). Install shaft nut lock washers and nuts (fig. 178). Tighten nuts securely with



RA PD 25505

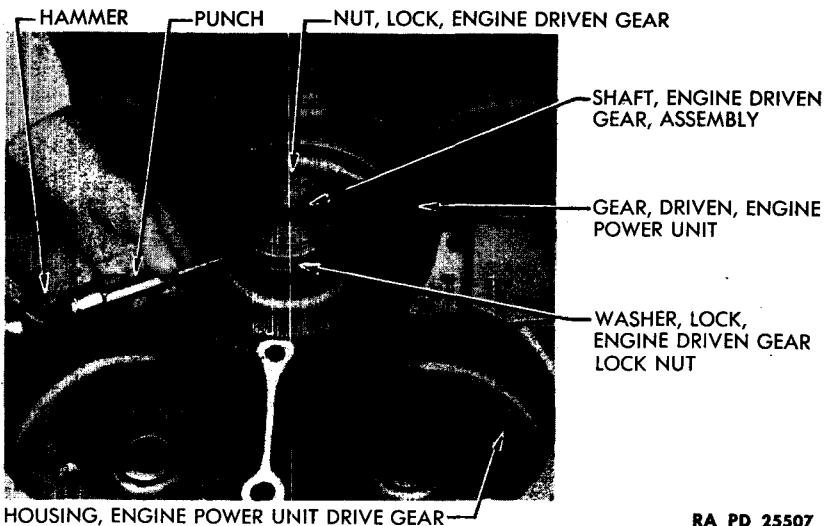
Figure 164 — Installing Engine Driven Gear Lock Nut

ORDNANCE MAINTENANCE — POWER UNIT FOR  
MEDIUM TANKS M3A4 AND M4A4



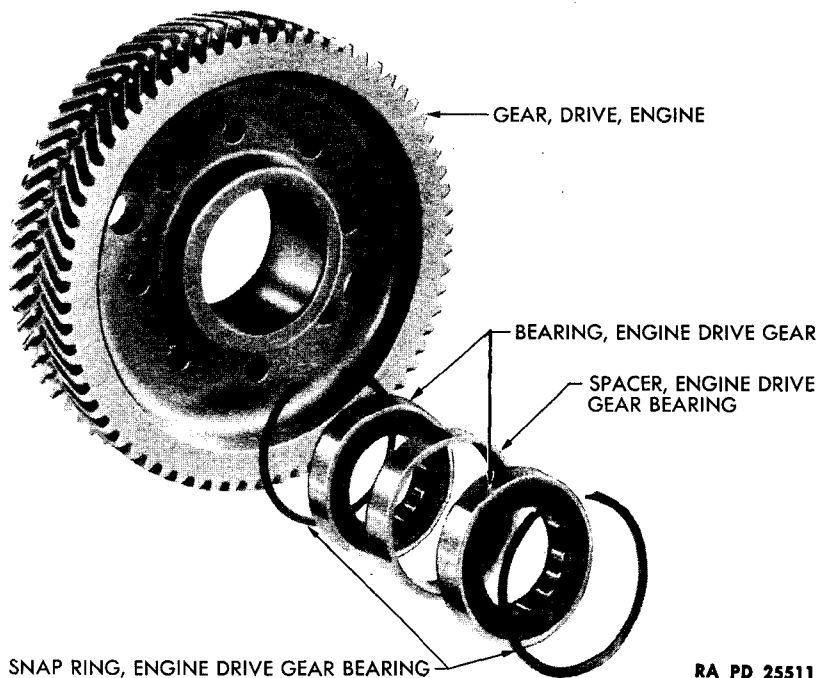
**Figure 165 — Tightening Engine Driven Gear Lock Nut**

2 1/8-inch socket wrench (fig. 179). NOTE: If shaft should turn in housing, place a bar in the opening at the opposite end of shaft and bind shaft in housing until nut is tightened. Using hammer and drift, bend tabs on lock washers to secure nuts (fig. 180).



**Figure 166 — Bending Tabs Of Engine Driven Gear Lock Nut Lock Washer**

ASSEMBLY OF POWER UNIT



RA PD 25511

**Figure 167 — Engine Drive Gear, Bearings And Snap Ring, Exploded**

**(23) SECURE ENGINE DRIVEN GEAR SHAFT IN HOUSING.**

**DRIFT**

**GAGE**, feeler

**HAMMER**, steel

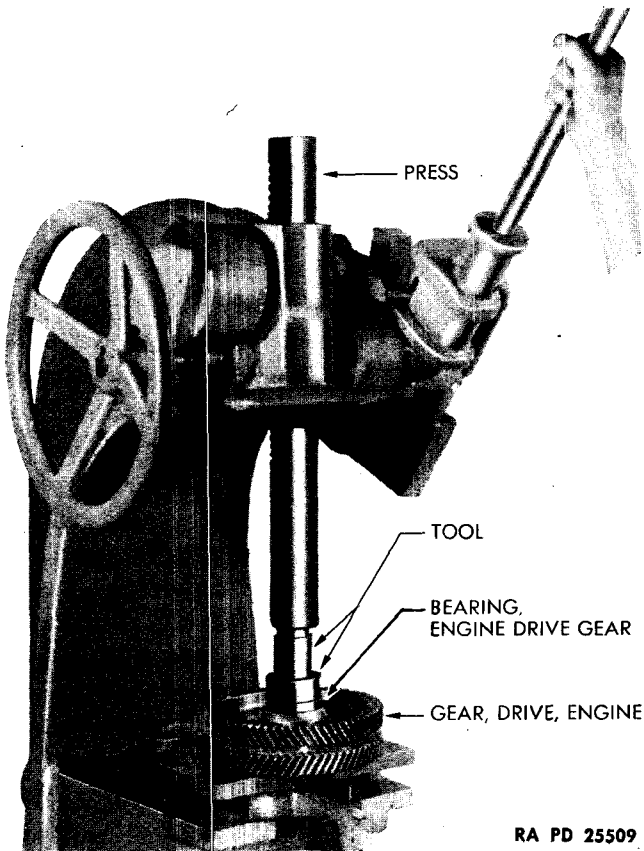
**WRENCH**, socket,  $\frac{9}{16}$ -in.

**WRENCH**, spanner drive front bearing lock nut, MTM-A4-2

**WRENCH**, torque

Remove 6 cap screws and remove bearing retaining plate ( $\frac{9}{16}$ -in. socket wrench) (fig. 160). Install engine driven gear shaft outer bearing retainer nut lock washer and nut (figs. 181 and 182). Using Spanner wrench MTM-A4-2, and with holding tool in position on shaft, tighten nut securely (300 to 450 foot-pounds) (fig. 183). Use a hammer and drift to bend tabs of lock nut into recesses in nut to secure nut in position (fig. 184). Install oil seal in engine driven gear shaft oil seal retainer (fig. 185). *Wrap a piece of thin shim stock or use a tapered sleeve on shaft* (fig. 186) (to prevent damage to seal through coming in contact with shoulder on shaft) and install retainer over shaft and into position on housing. **NOTE:** Do not use gasket between retainer and housing while checking. Hold retainer tight against bearing and check clearance between retainer and housing (fig. 187). Select a gasket the same thickness as indicated by feeler gage. **NOTE:** Gaskets, 0.020 inch, 0.025 inch, and 0.030 inch thick,

ORDNANCE MAINTENANCE — POWER UNIT FOR  
MEDIUM TANKS M3A4 AND M4A4



**Figure 168 — Installing Bearing In Engine Drive Gear**

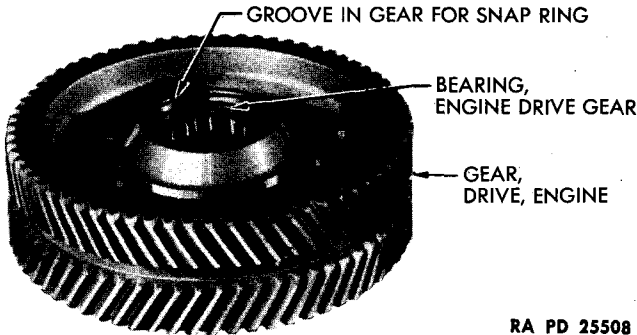
are provided for this purpose. Remove retainer from housing, install gasket of the proper thickness (fig. 188) and reinstall retainer. Remove sleeve from shaft and secure retainer with the 6 cap screws and lock washers ( $\frac{1}{16}$ -in. socket wrench) (fig. 189).

(24) INSTALL POWER UNIT DRIVE GEAR HOUSING ASSEMBLY (fig. 190).

HOIST  
WRENCH, MTM-A4-11, and  
extension  
WRENCH, plug, square,  $\frac{1}{2}$ -in.  
WRENCH, socket,  $\frac{5}{8}$ -in.  
WRENCH, socket,  $\frac{9}{8}$ -in.

WRENCH, socket,  $\frac{5}{8}$ -in.  
WRENCH, socket,  $\frac{3}{4}$ -in.  
WRENCH, socket,  $\frac{7}{8}$ -in.  
WRENCH, socket,  $\frac{15}{8}$ -in.  
WRENCH, torque

ASSEMBLY OF POWER UNIT



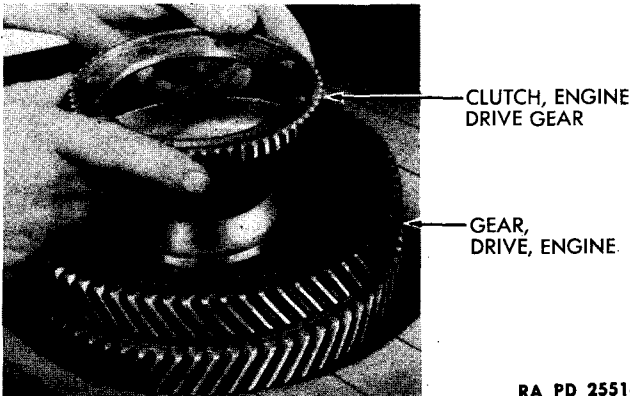
RA PD 25508

**Figure 169 – Engine Drive Gear Showing Bearing In Position**

(a) Check the oil distributor plugs in end of engine oil gallery. The plugs in engines Nos. 1, 2, and 5 must have a  $\frac{1}{8}$ -inch hole to provide oil for the drive gears (fig. 155).

Plugs in engines Nos. 3 and 4 are not provided with a hole. Be sure drive gears are properly indexed with corresponding gears and that engine driven gear shaft is locked in position to prevent turning.

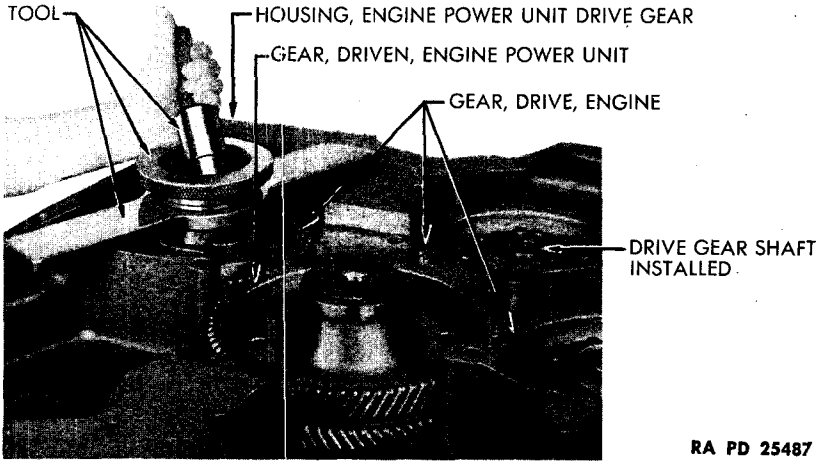
(b) Position new drive gear housing gasket over dowels and secure to engines with gasket cement. Lift drive gear housing assembly with hoist and slide into position on doweled studs, two at top and one at bottom until housing is within  $\frac{1}{2}$  inch of being in position. Sight through engine drive gear housing timing opening (one for each engine) and check alignment of zeros on clutch and sleeve (fig. 191). When zeros on all gears and sleeves are matched slide housing into position. Recheck zeros to be sure they are properly matched.



RA PD 25514

**Figure 170 – Installing Engine Drive Gear Clutch On Drive Gear**

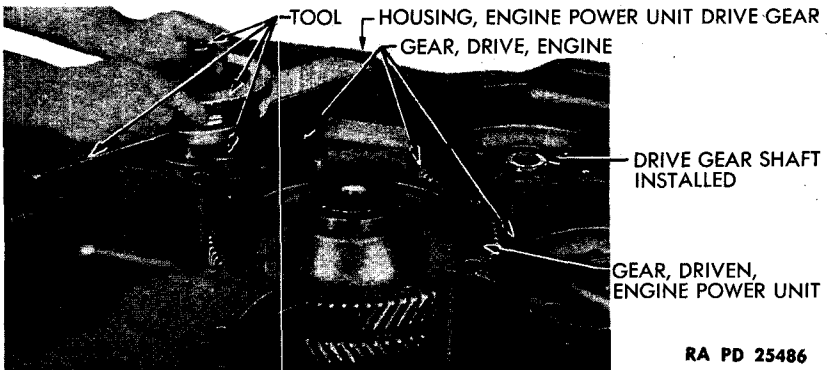
**ORDNANCE MAINTENANCE — POWER UNIT FOR  
MEDIUM TANKS M3A4 AND M4A4**



**Figure 171 — Alining Engine Drive Gear In Housing**

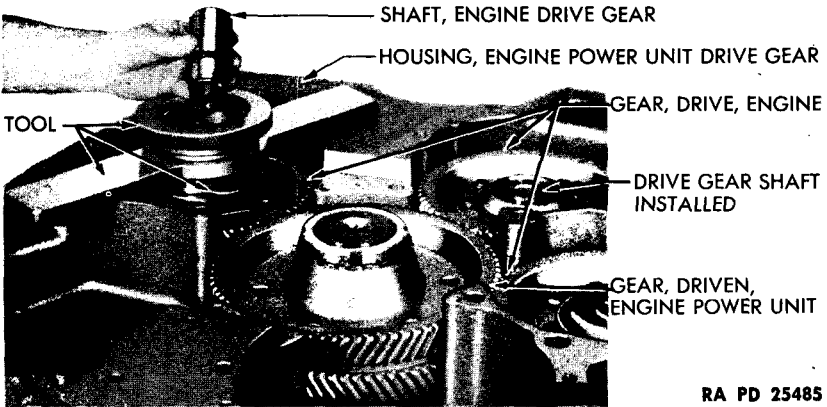
(c) Install nuts on mounting studs and tighten sufficiently to draw housing tight against crankcase. Tighten nuts to 110 to 120 foot-pounds ( $\frac{1}{8}$ -in. socket wrench and torque wrench). Install 15 cap screws and lock washers (from radiator end) from gear case housing to engine cylinder blocks and tighten to 30 to 35 foot-pounds ( $\frac{3}{8}$ -in. socket wrench and torque wrench). Install 4 cap screws and lock washers from drive gear housing to crankcase and tighten to 55 to 60 foot-pounds ( $\frac{3}{4}$ -in. socket wrench and torque wrench). Install 2 cap screws and lock washers from gear case housing to crankcase, at bottom, and tighten to 30 to 35 foot-pounds ( $\frac{1}{8}$ -in. socket wrench and torque wrench).

(d) Install cap screws and lock washers (from distributor end) from engine to gear case housing. Two cap screws are used on each side of



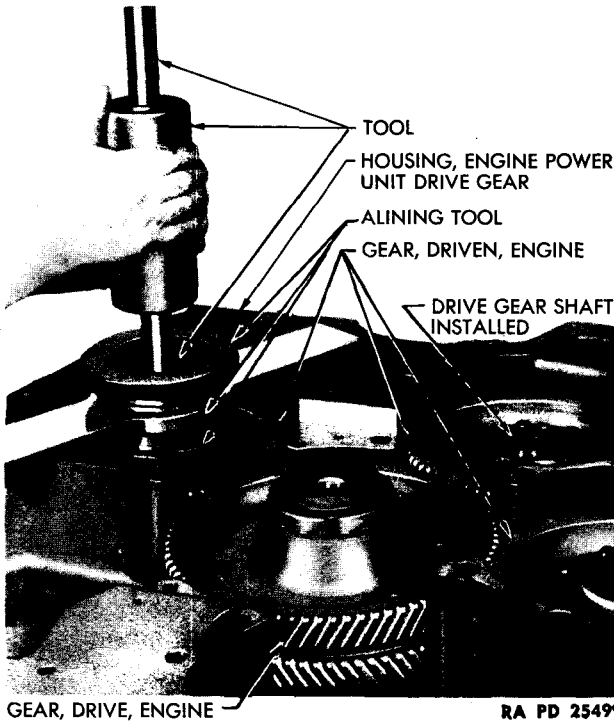
**Figure 172 — Inserting Shaft Plug Alining Tool To Aline Gear**

**ASSEMBLY OF POWER UNIT**



**Figure 173 — Installing Engine Drive Gear Shaft In Gear**

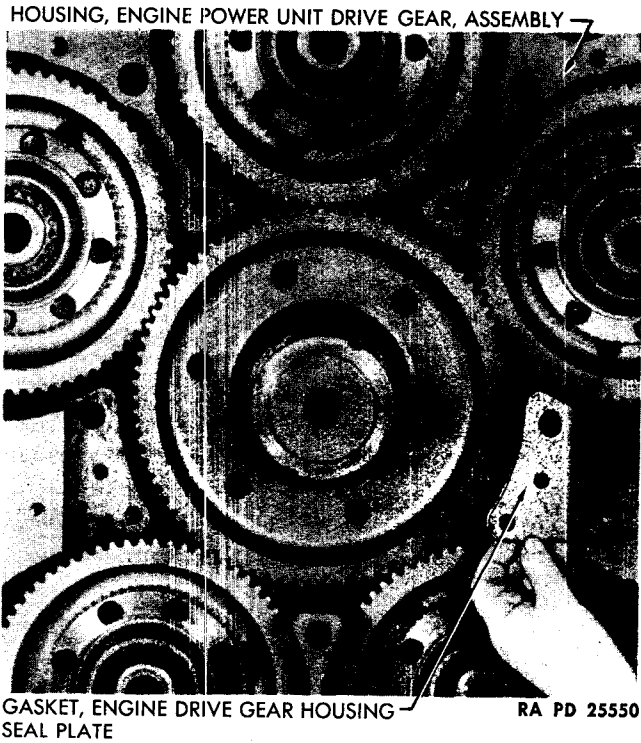
each engine. Tighten the small cap screw to 30 to 35 foot-pounds ( $\frac{3}{8}$ -in. socket wrench). Tighten the large cap screw to 40 to 45 foot-pounds ( $\frac{5}{8}$ -in. socket wrench). **NOTE:** It will be necessary to use wrench and extension MTM-A4-11 to tighten these cap screws on the upper side of



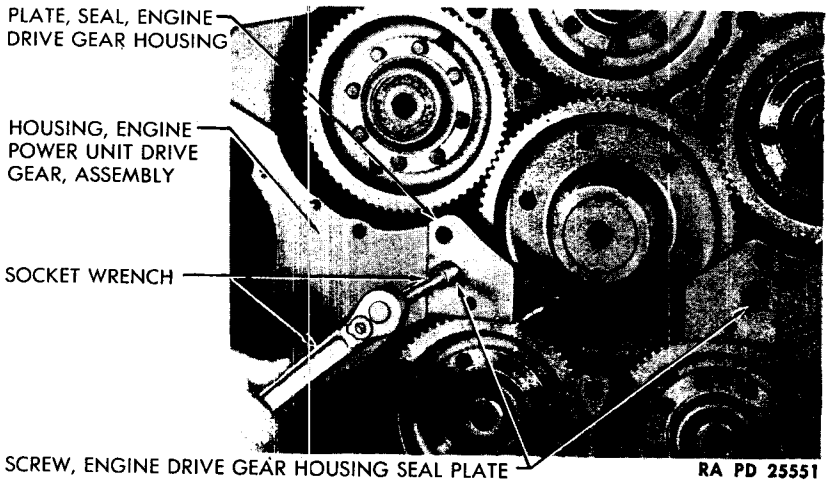
**Figure 174 — Driving Engine Drive Gear Shaft Into Position In Housing**



ORDNANCE MAINTENANCE — POWER UNIT FOR  
MEDIUM TANKS M3A4 AND M4A4

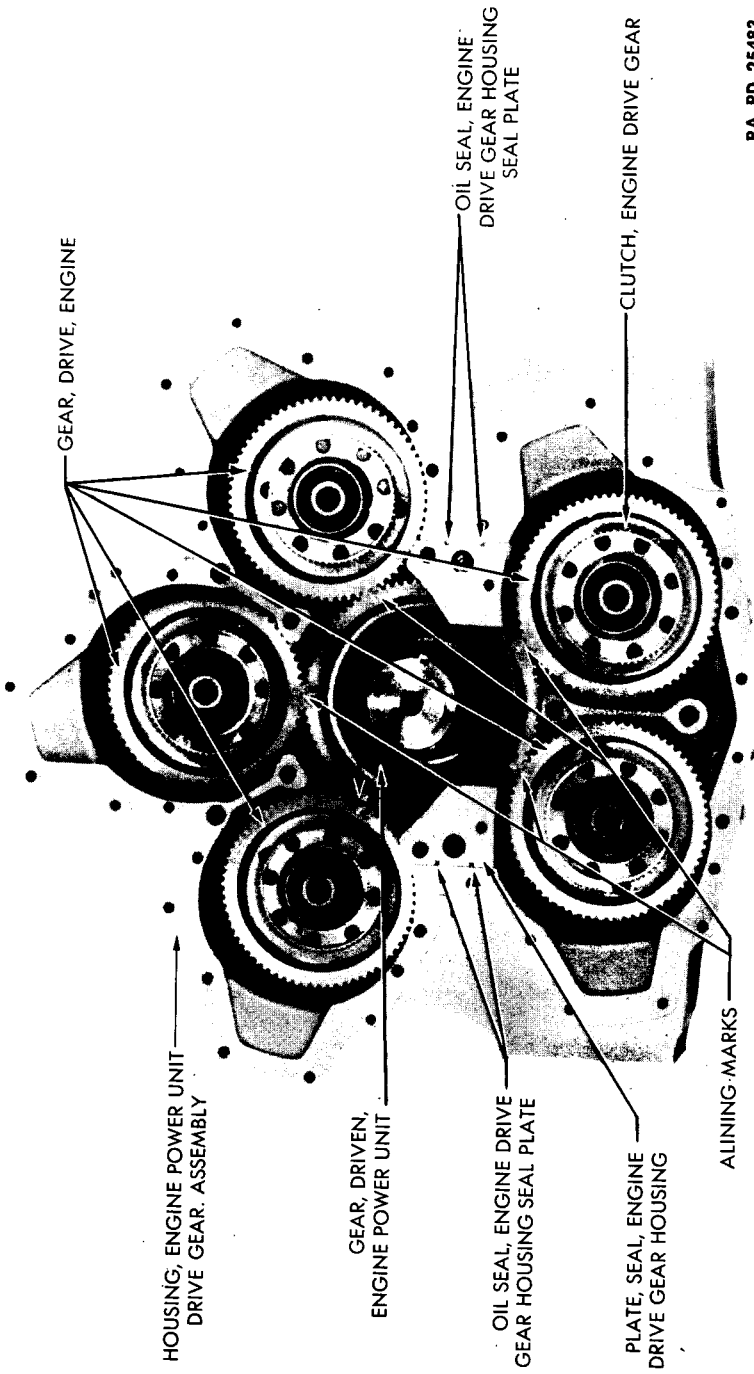


**Figure 175 — Installing Engine Drive Gear Housing Seal Plate Gasket**



**Figure 176 — Installing Engine Drive Gear Housing Seal Plate**

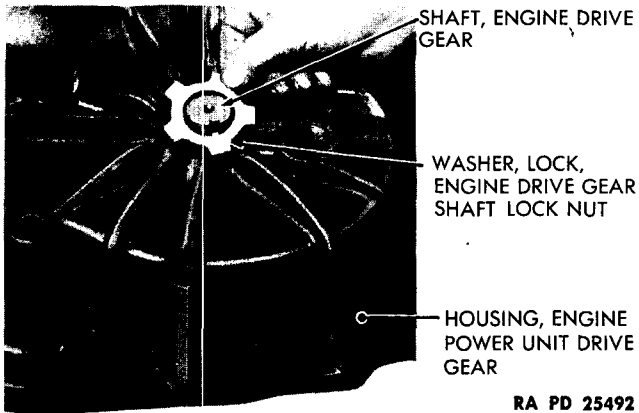
ASSEMBLY OF POWER UNIT



RA PD 25483

Figure 177 — Engine Drive Gear Housing (Gear Side)

**ORDNANCE MAINTENANCE — POWER UNIT FOR  
MEDIUM TANKS M3A4 AND M4A4**



**Figure 178 — Installing Engine Drive Gear Shaft Lock Nut Lock Washer**

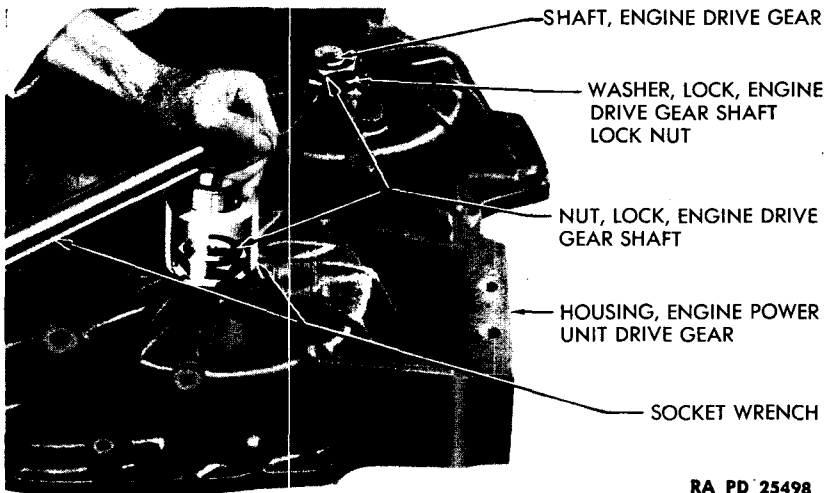
No. 4 engine. After tightening these cap screws on the upper side of No. 4 engine, install the cap screw and lock washer (at radiator end) from No. 4 engine to crankcase. This cap screw was not installed when the No. 4 engine was installed.

(e) *Remove Hoist And Sling.*

(f) *Install Engine Front Supports—Right And Left.*

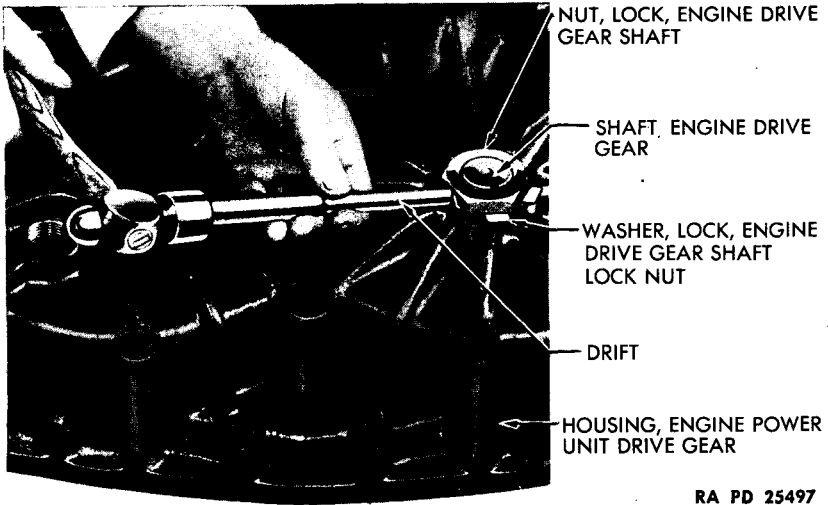
BAR, pinch

WRENCH, socket, 7/8-in.



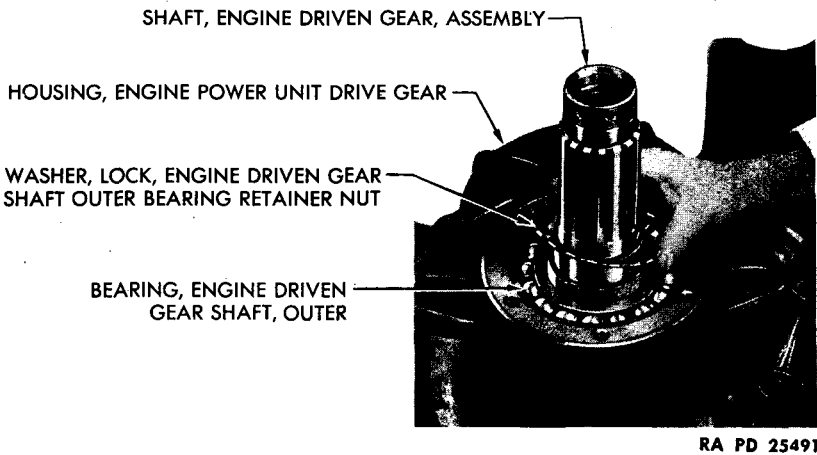
**Figure 179 — Tightening Engine Drive Gear Shaft Lock Nut**

ASSEMBLY OF POWER UNIT



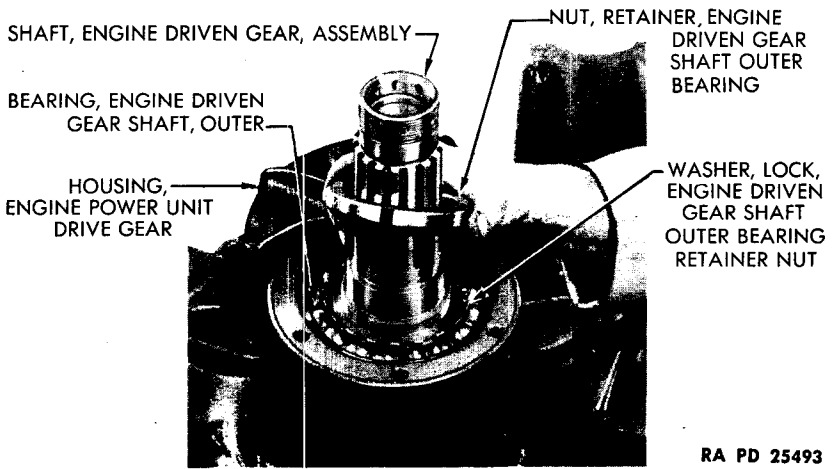
**Figure 180 – Bending Tabs Of Engine Drive Gear Shaft Lock Nut Lock Washer**

Position engine right front support on drive gear housing (fig. 192), and secure with 1 engine front support long upper screw and lock washer, 2 engine front support long lower screws and 2 engine front support short lower screws. Tighten screws securely ( $\frac{7}{8}$ -in. socket wrench). Repeat operation to install left support. Using pinch bar, screw engine support eyebolt in each support (fig. 192).



**Figure 181 – Installing Engine Driven Gear Shaft Outer Bearing Retainer Nut Lock Washer**

**ORDNANCE MAINTENANCE – POWER UNIT FOR  
MEDIUM TANKS M3A4 AND M4A4**



RA PD 25493

**Figure 182 – Installing Engine Driven Gear Shaft Outer Bearing Retainer Nut**

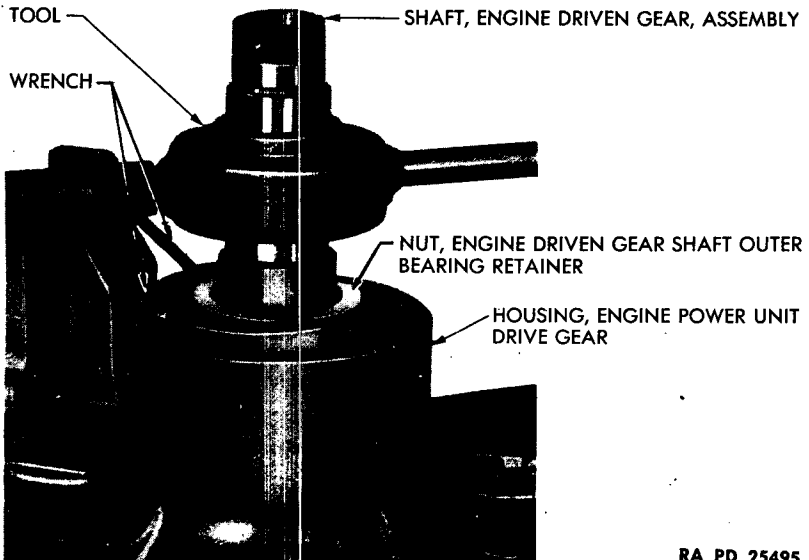
(g) *Install The 5 Engine Drive Gear Housing Timing Hole Plugs.*

Use 1/2-inch square plug wrench (fig. 191) to install the 5 timing hole plugs.

(25) **INSTALL STARTER.**

**PLIERS**, side cutting

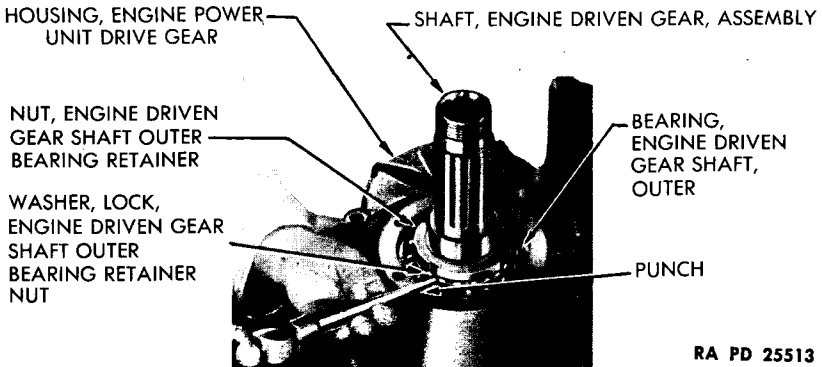
**WRENCH**, 7/8-in.



RA PD 25495

**Figure 183 – Tightening Engine Driven Gear Shaft Outer Bearing Retainer Nut**

**ASSEMBLY OF POWER UNIT**



**Figure 184 – Bending Tabs Of Engine Driven Gear Shaft Outer Bearing Retainer Nut**

Place starter in position on mounting bracket and secure with 4 cap screws and lock washers, 2 short screws toward radiator end. Tighten cap screws securely and lock in place with locking wires (fig. 193).

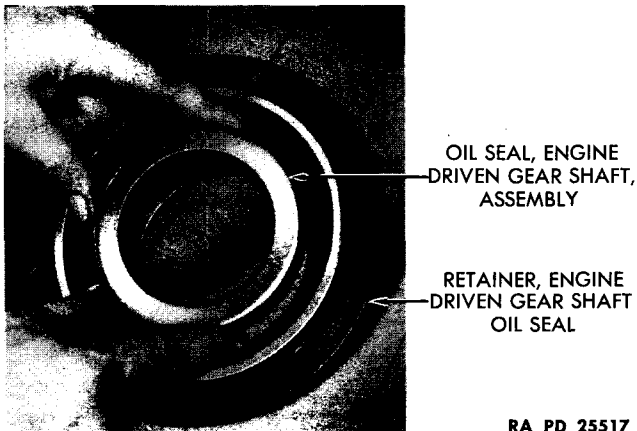
(26) INSTALL CHOKE CONTROL ROD CROSS SHAFT ASSEMBLY (fig. 193).

WRENCH,  $\frac{9}{16}$ -in.

Place assembly in position and attach brackets to drive gear housing directly opposite engines Nos. 2 and 5, with 2 cap screws each.

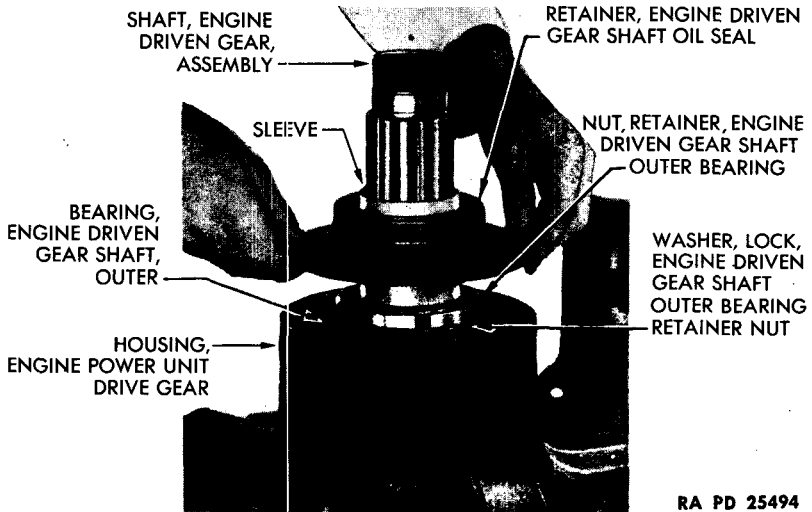
(27) INSTALL EXHAUST STACK TEMPERATURE SIGNAL SENDING UNITS (fig. 10).

WRENCH,  $\frac{3}{8}$ -in.



**Figure 185 – Installing Oil Seal In Engine Driven Gear Shaft Oil Seal Retainer**

**ORDNANCE MAINTENANCE — POWER UNIT FOR  
MEDIUM TANKS M3A4 AND M4A4**



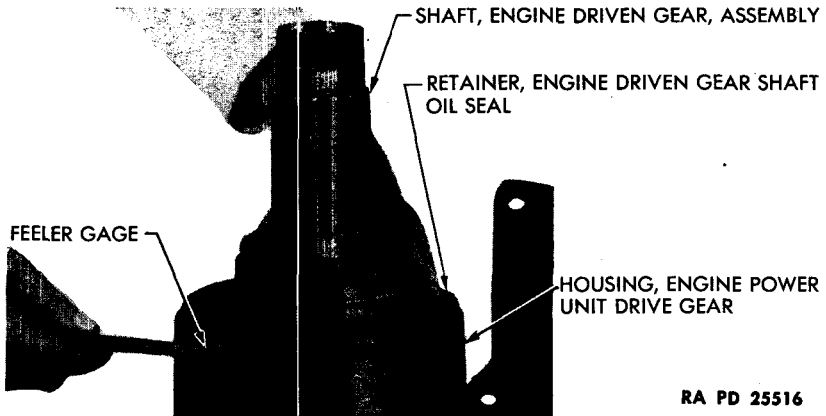
**Figure 186 — Installing Engine Driven Gear Shaft Oil Seal Retainer**

Mount 1 exhaust stack temperature signal sending unit over the 2 studs on the manifold of each engine (near radiator end) and secure with 2 nuts and lock washers.

(28) **INSTALL HIGH WATER TEMPERATURE WARNING INDICATOR SENDING UNITS** (figs. 5 and 10).

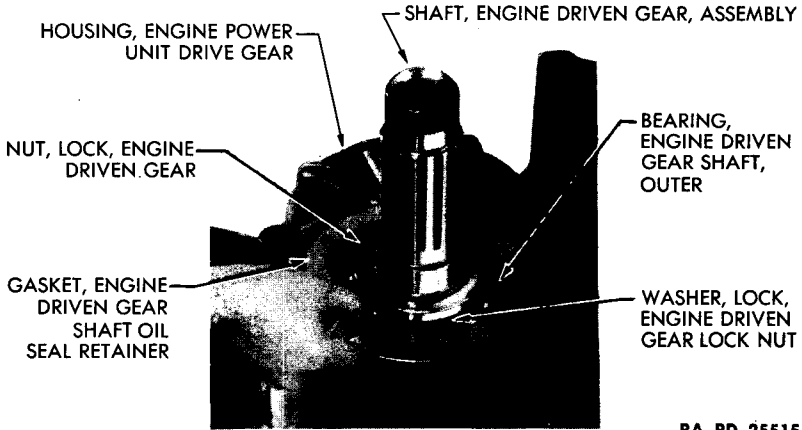
**WRENCH, 7/8-in.**

Paint threads of unit with suitable sealing compound and screw one unit into opening in cylinder head adapter of each engine (multiple water



**Figure 187 — Checking Clearance Between Retainer  
And Engine Drive Gear Housing**

ASSEMBLY OF POWER UNIT



RA PD 25515

Figure 188 — Installing Engine Driven Gear Shaft Oil Seal Retainer Gasket

pump type) (fig. 10) and into adapter of No. 1 engine only (single water pump type) (fig. 5).

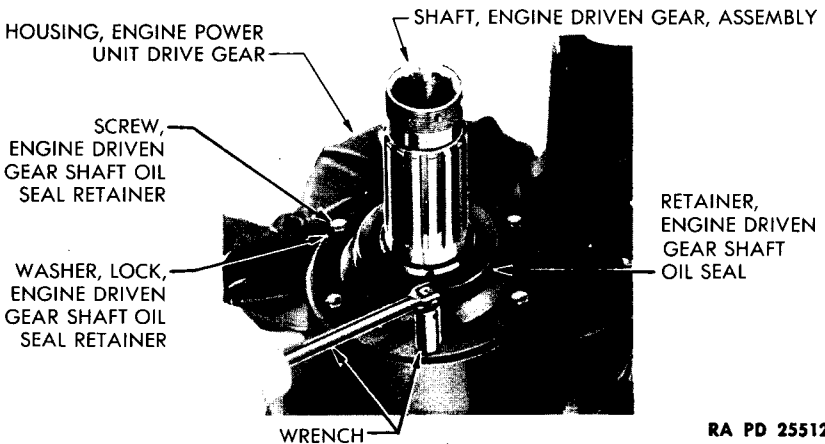
(29) INSTALL WATER TEMPERATURE GAGE SENDING UNITS.

WRENCH, 1-in.

Paint threads of units with a suitable sealing compound and screw unit into the opening in right side of cylinder head of each engine (fig. 10).

(30) INSTALL LOW OIL PRESSURE WARNING INDICATOR SENDING UNIT.

WRENCH,  $\frac{1}{8}$ -in.

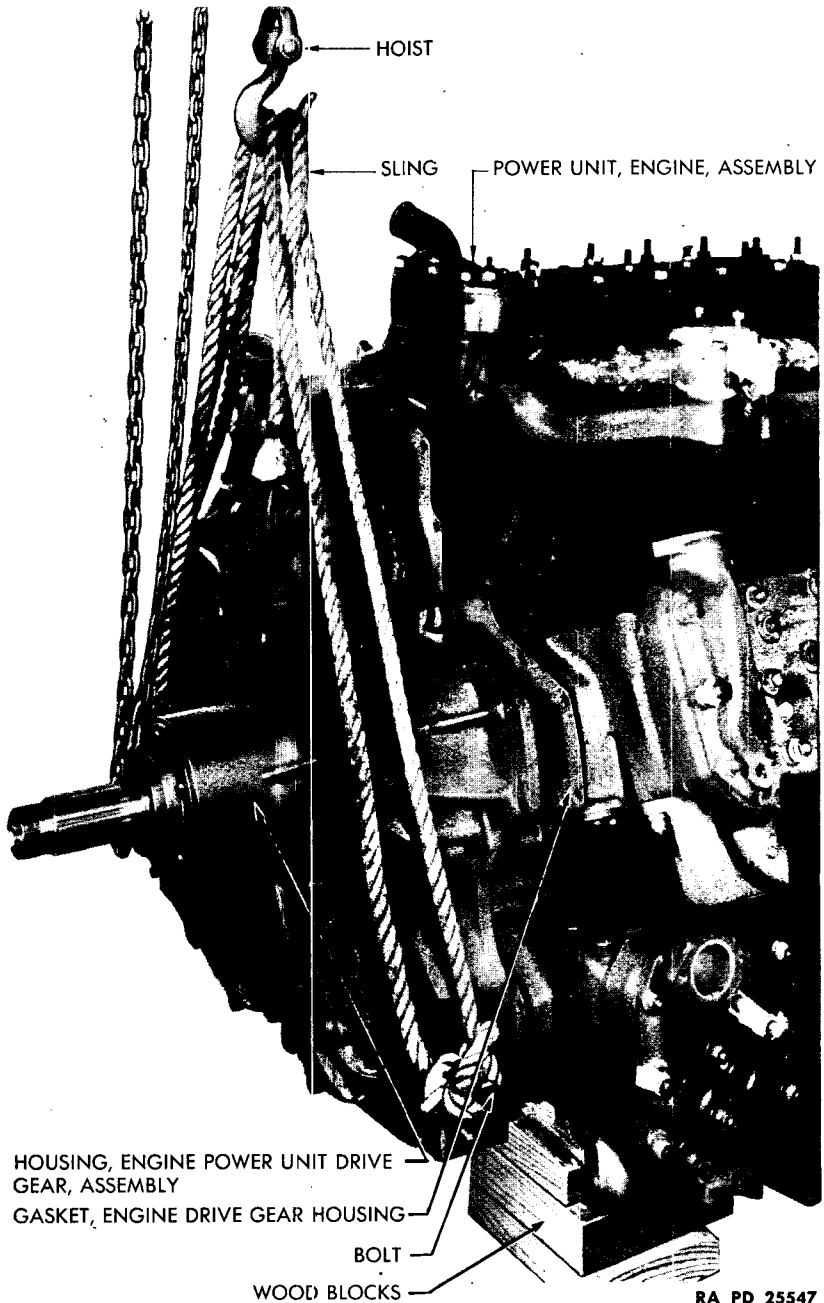


RA PD 25512

Figure 189 — Tightening Engine Driven Gear Shaft Oil Seal Retainer Screws



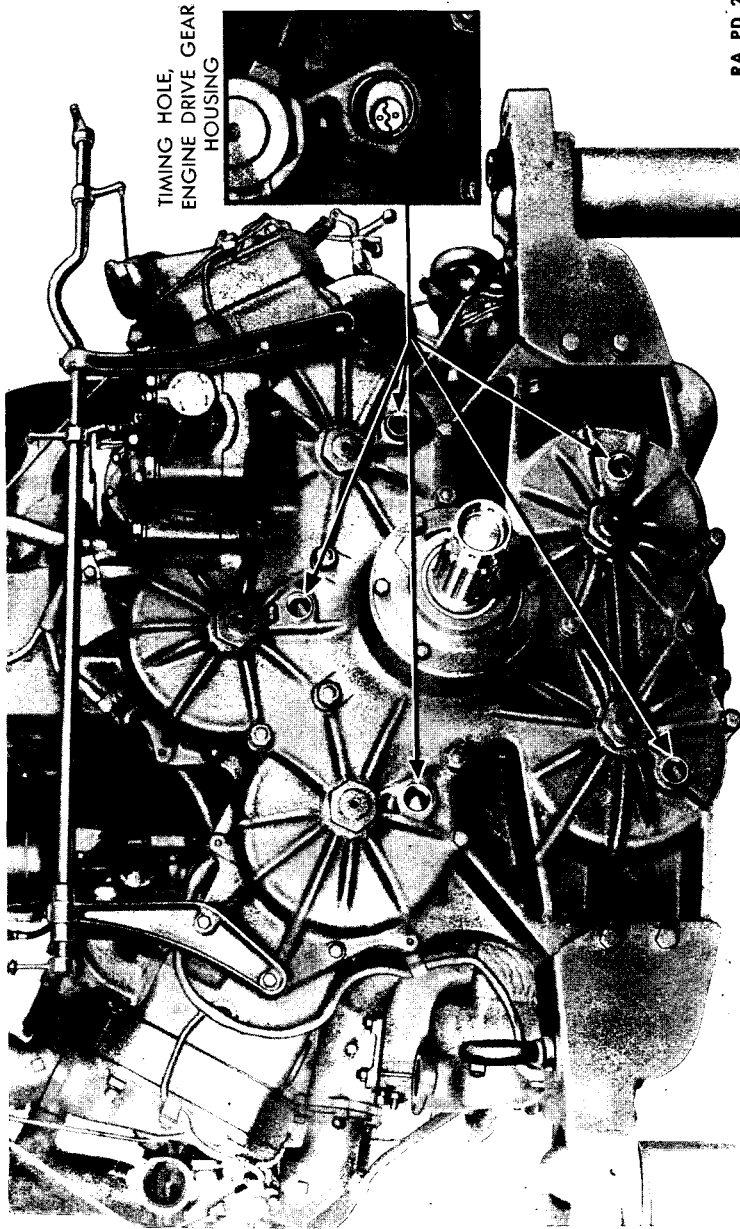
ORDNANCE MAINTENANCE — POWER UNIT FOR  
MEDIUM TANKS M3A4 AND M4A4



RA PD 25547

Figure 190 — Installing Engine Drive Gear Housing Assembly

ASSEMBLY OF POWER UNIT

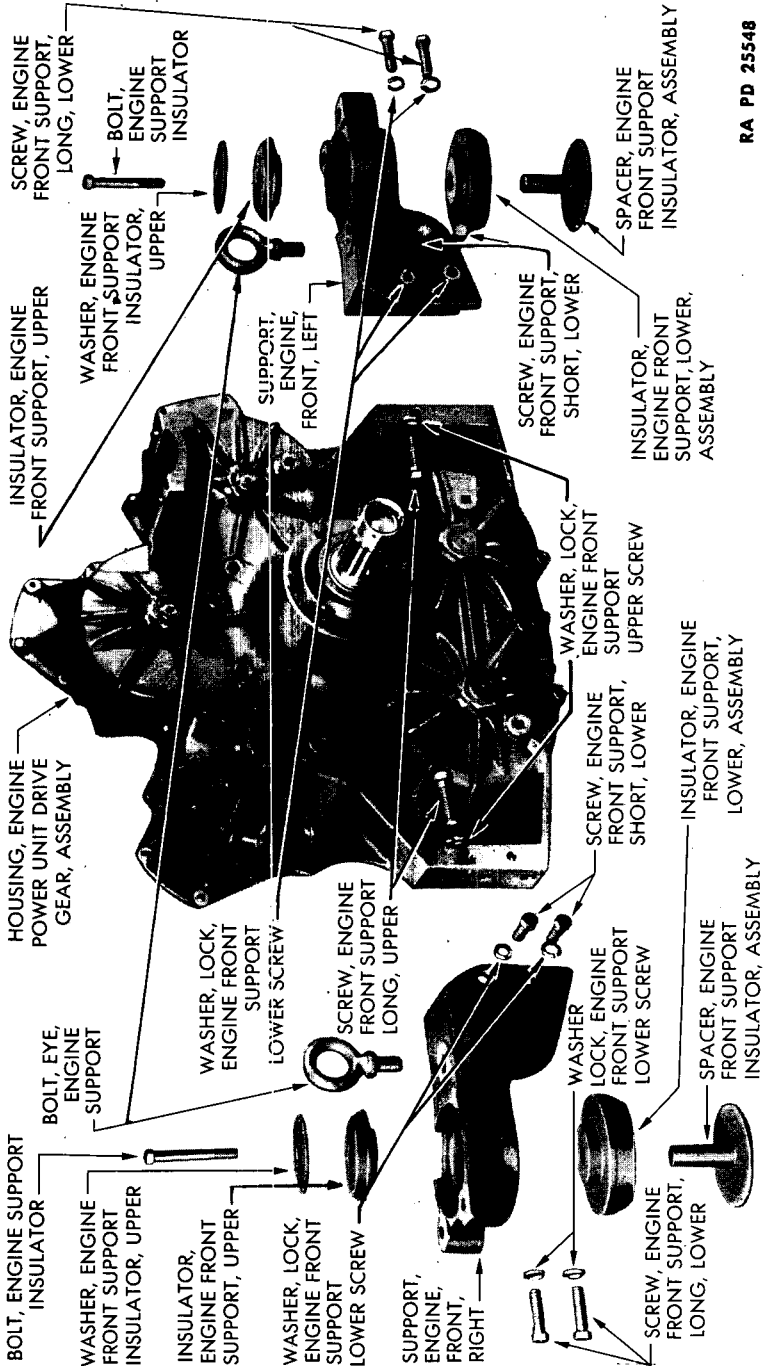


TIMING HOLE,  
ENGINE DRIVE GEAR  
HOUSING

RA PD 25345

Figure 191 — Openings In Power Unit For Checking Indexing Of Engine Drive Gears And Engine Drive Clutch Sleeve

ORDNANCE MAINTENANCE - POWER UNIT FOR  
MEDIUM TANKS M3A4 AND M4A4



RA PD 25548

Figure 192 - Engine Drive Gear Housing And Front Supports, Exploded

## ASSEMBLY OF POWER UNIT

Paint threads of unit with suitable sealing compound and screw unit into opening in underside of No. 4 engine, toward distributor end (on multiple water pump type (fig. 11) and into opening in right side of No. 1 engine, toward radiator end (on single water pump type)) (fig. 3).

### (31) INSTALL OIL PRESSURE GAGE SENDING UNITS.

WRENCH, open-end,  $\frac{7}{16}$ -in.

Paint threads of unit with suitable sealing compound and screw unit into opening on underside of No. 4 engine, toward radiator end, on multiple water pump type (fig. 11). On single water pump type, this unit is mounted on upper side of No. 3 engine, by screwing nipple and elbow into opening in No. 3 engine and screwing unit into elbow (fig. 9). **CAUTION:** When installing these units, be sure that the letters "UP" (stamped on large diameter of unit) are at top of unit when installed. This is necessary to prevent oil from accumulating in unit, which renders the unit inoperative.

### (32) INSTALL SENDING UNIT HARNESS ASSEMBLY.

PLIERS, side cutting

WRENCH,  $\frac{5}{8}$ -in.

SCREWDRIVER

Mount bracket and connector over 2 cylinder head studs on No. 2 engine and secure with 2 nuts (fig. 193). Locate harness on the various engines, according to identification tags which were attached at time of disassembly. Secure to drive gear housing and cylinder head screws by securing clips. Connect ends of wires to sending units, install shields on end of units and secure with 2 slotted screws each. Connect wires to exhaust stack temperature warning signal sending units, with 1 screw each, and lock screws in place with locking wires.

### (33) INSTALL LIFTING EYES IN POWER UNIT REAR SUPPORT.

BAR, pinch, 18-in.

Screw the 2 lifting eyes in support, tightening securely.

### (34) MOUNT ASSEMBLY ON STAND.

HOIST

STAND, overhaul, MTM-A4-

SLING, MTM-A4-18

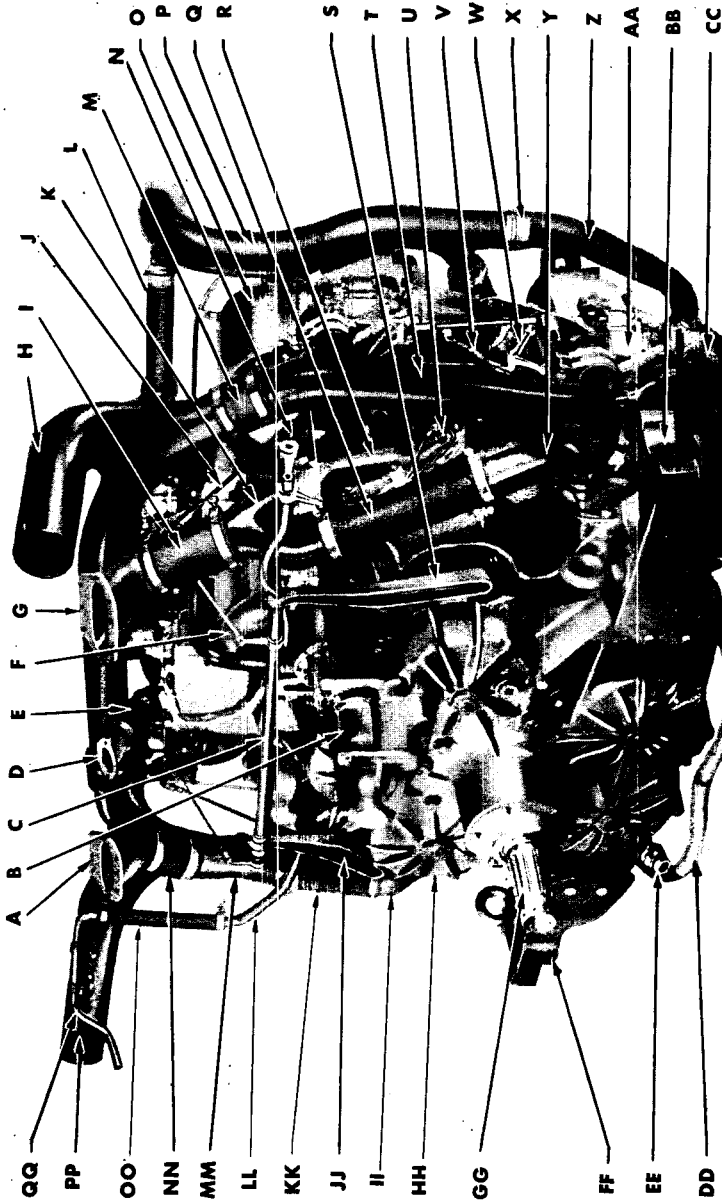
29

Connect sling to the 2 lifting eyes in rear support and to lifting eye in each front support, raise assembly with hoist and mount on stand, to facilitate assembly.

### (35) INSTALL GENERATOR (MULTIPLE WATER PUMP TYPE ONLY) (fig. 1).

WRENCH,  $\frac{5}{8}$ -in.

ORDNANCE MAINTENANCE — POWER UNIT FOR  
MEDIUM TANKS M3A4 AND M4A4



RA PD 25372

Figure 193 — Power Unit Less Radiator And Clutch

ASSEMBLY OF POWER UNIT

- A—INLET, RADIATOR, RIGHT  
 B—MOTOR, STARTER, ASSEMBLY  
 C—SHAFT, CROSS, CHOKE CONTROL, ASSEMBLY  
 D—INLET, CENTER, RADIATOR  
 E—HOSE, INLET, RADIATOR  
 F—MANIFOLD, INTAKE AND EXHAUST, ASSEMBLY (NO. 1 ENGINE)  
 G—INLET, RADIATOR, LEFT  
 H—TUBE, CARBURETOR TO AIR CLEANER, UPPER, LEFT, ASSEMBLY  
 I—HOSE, INLET, RADIATOR, LEFT  
 J—ROD, THROTTLE CONTROL (FROM NO. 1 TO NO. 5 CARBURETOR)  
 K—ELBOW, OUTLET, CYLINDER WATER (NO. 2 ENGINE)  
 L—TUBE, W/CLAMP, EXHAUST PIPE, LEFT, ASSEMBLY  
 M—HOSE, CONNECTING, CARBURETOR AIR TUBE  
 N—PLUG, CONNECTOR, WIRE CABLE (FEMALE END)  
 O—GENERATOR AND SHIELD  
 P—PIPE, EXHAUST, UPPER, LEFT, ASSEMBLY  
 Q—HOSE, ENGINE RADIATOR INLET (ENGINE NO. 3)  
 R—ADAPTER, CYLINDER HEAD (NO. 2 ENGINE)  
 S—BRACKET, CROSS SHAFT, CHOKE CONTROL, LEFT  
 T—TUBE, CARBURETOR TO AIR CLEANER, LOWER  
 U—UNIT, SENDING, ENGINE WATER TEMPERATURE, ASSEMBLY  
 V—SPRING, PULL-BACK, THROTTLE CONTROL  
 W—BELLCRANK, THROTTLE CONTROL  
 X—CLAMP, EXHAUST PIPE, LOWER ASSEMBLY  
 Y—TUBE, WATER OUTLET (NO. 3 ENGINE)  
 Z—PIPE, EXHAUST, LOWER, LEFT  
 AA—CARBURETOR, ASSEMBLY (NO. 3 ENGINE)  
 BB—SUPPORT, ENGINE, FRONT, LEFT  
 CC—ELBOW, INTAKE MANIFOLD (NO. 3 ENGINE)  
 DD—HOSE, OIL, ENGINE OUTLET TO RADIATOR  
 EE—HOSE, OIL, ENGINE INLET TO RADIATOR  
 FF—SUPPORT, ENGINE, FRONT, RIGHT  
 GG—SHAFT, ENGINE DRIVEN GEAR, ASSEMBLY  
 HH—HOUSING, ENGINE DRIVE GEAR, ASSEMBLY  
 II—ELBOW, OUTLET, CYLINDER WATER (NO. 4 ENGINE)  
 JJ—BRACKET, CROSS SHAFT, CHOKE CONTROL, RIGHT  
 KK—HOSE, ENGINE RADIATOR INLET (ENGINE NO. 4)  
 LL—PIPE, OUTLET, CRANKCASE VENTILATOR AIR CLEANER  
 MM—ELBOW, OUTLET, CYLINDER WATER (NO. 5 ENGINE)  
 NN—HOSE, INLET, RADIATOR, RIGHT  
 OO—HOSE, OIL TANK AIR VENT TUBE  
 PP—TUBE, CARBURETOR TO AIR CLEANER, UPPER, RIGHT, ASSEMBLY  
 QQ—TUBE, OIL TANK AIR VENT

RA PD 25372B

Legend For Figure 193 — Power Unit Less Radiator And Clutch

**ORDNANCE MAINTENANCE — POWER UNIT FOR  
MEDIUM TANKS M3A4 AND M4A4**

Mount generator and bracket assembly on No. 2 engine, fitting upper end of bracket over 2 cylinder head studs, and secure with 2 cap screws at lower end of bracket and 2 nuts at upper end of bracket.

**(36) INSTALL CARBURETORS.****PLIERS**, side cutting**WRENCH**,  $\frac{9}{16}$ -in.

Select the proper intake manifold elbow (used on engines Nos. 2, 3, 4, and 5 only), position new gasket on manifold, and secure elbow to manifold with 4 lock washers and nuts ( $\frac{9}{16}$ -in. wrench). Mount all elbows with carburetor mounting face "UP." Select the proper carburetor and governor assembly, position new gasket on elbow (on manifold on No. 1 engine only), mount assembly on studs and secure with 2 nuts and lock washers ( $\frac{9}{16}$ -in. wrench). Secure nuts with locking wires (side-cutting pliers).

**(37) INSTALL CARBURETOR TO AIR CLEANER TUBES.**

Position new hose clamps on each carburetor air inlet, place new hose on each opening and position hose clamps on hose. Position new hose clamps on tubes, where they connect across top of power unit, and connect at the 3 places with hose (fig. 156). (Do not tighten clamps to permit altering alinement.) With new hose clamps in position on tubes, at 5 points where they connect to carburetors, insert ends of tubes in hose which extend from each carburetor. Position all hose clamps on hose, but do not tighten.

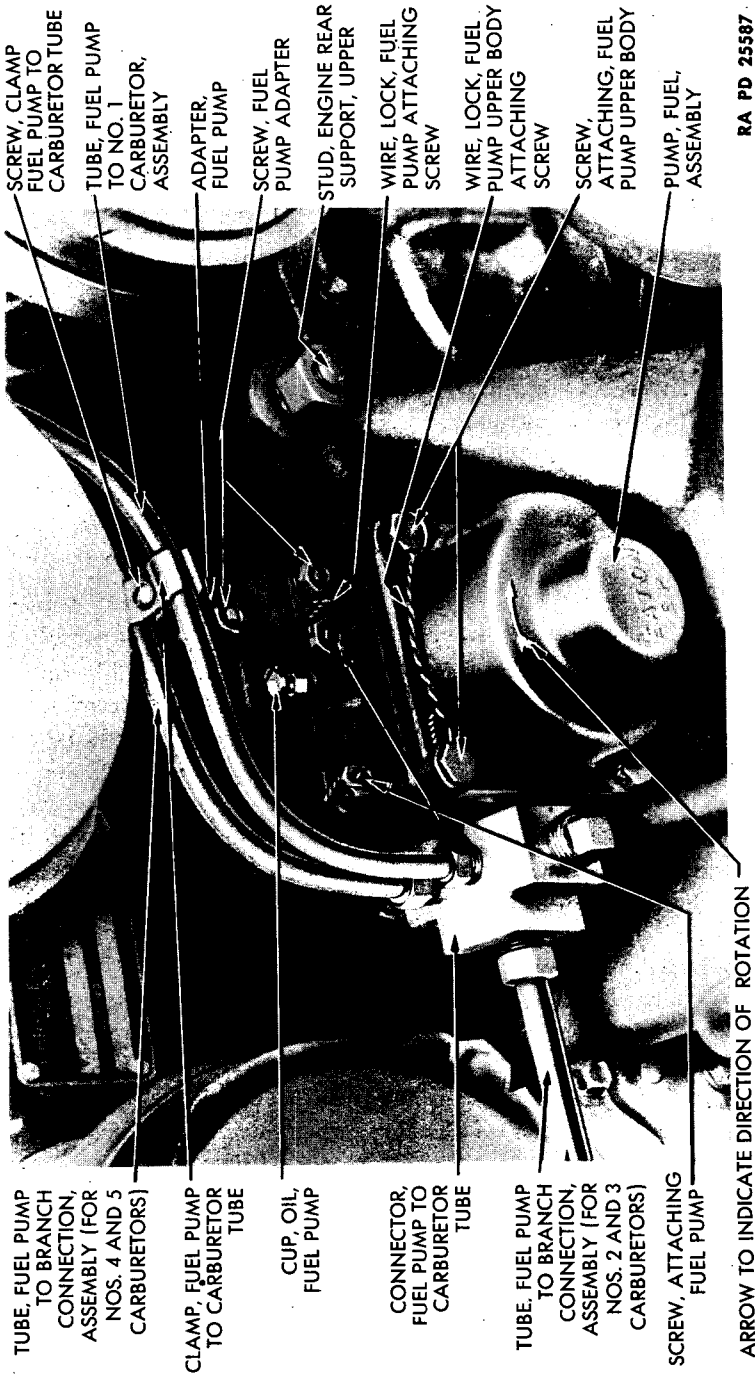
**(38) INSTALL FUEL PUMP (MULTIPLE WATER PUMP TYPE ONLY).****PLIERS**, side cutting**WRENCH**, torque**WRENCH**, open-end,  $\frac{1}{2}$ -in.

Position new gasket on fuel pump adapter (on distributor end of crankcase). Mount pump (with arrow indicating clockwise rotation) on adapter and secure with 4 cap screws and lock washers. Tighten cap screws to 15 to 20 foot-pounds ( $\frac{1}{2}$ -in. open-end wrench and torque wrench). Lock cap screws in place with locking wires, through holes in cap screwheads (side cutting pliers).

**(39) INSTALL FUEL TUBES (MULTIPLE WATER PUMP TYPE ONLY).****WRENCH**,  $\frac{5}{8}$ -in.**WRENCH**, open-end,  $\frac{5}{8}$ -in.**WRENCH**, open-end,  $\frac{9}{16}$ -in.

Select the proper fuel line from fuel pump to No. 1 carburetor. Connect tube to fuel pump ( $\frac{5}{8}$ -in. open-end wrench). Connect end of flexible tubing (attached to other end of tube) to No. 1 carburetor. Tighten connections securely ( $\frac{9}{16}$ -in. open-end wrench). Attach tube clip to cylinder head stud ( $\frac{5}{8}$ -in. wrench). Select the proper fuel line from fuel pump

ASSEMBLY OF POWER UNIT



RA PD 25587

Figure 194 — Fuel Pump Installed On Multiple Water Pump Type Power Unit



**ORDNANCE MAINTENANCE — POWER UNIT FOR  
MEDIUM TANKS M3A4 AND M4A4**

to distribution block on No. 4 engine cylinder head. Connect line to fuel pump ( $\frac{5}{8}$ -in. open-end wrench). Install distributor block on No. 5 engine cylinder head studs ( $\frac{5}{8}$ -in. wrench). Connect fuel line to distribution block and tighten securely ( $\frac{5}{8}$ -in. open-end wrench). Secure line to No. 5 engine cylinder head stud with clip and nut ( $\frac{5}{8}$ -in. wrench). Connect flexible tubes from distribution block to carburetors Nos. 4 and 5 ( $\frac{9}{16}$ -in. open-end wrench). Tighten all connections securely. Place other fuel line in position and connect to fuel pump ( $\frac{5}{8}$ -in. open-end wrench). Connect distribution block to No. 3 engine cylinder head studs ( $\frac{5}{8}$ -in. wrench). Select and connect metal tube to distribution block ( $\frac{5}{8}$ -in. open-end wrench) and connect flexible tube, which is attached to opposite end of metal tube, to No. 2 carburetor ( $\frac{9}{16}$ -in. open-end wrench). Connect other metal tube to distribution block ( $\frac{5}{8}$ -in. open-end wrench) and connect flexible tube, which is attached to other end of metal tube, to No. 3 carburetor ( $\frac{9}{16}$ -in. open-end wrench). Attach metal tubes, with clips, to respective cylinder heads ( $\frac{5}{8}$ -in. wrench).

**(40) INSTALL FUEL TUBES (SINGLE WATER PUMP TYPE ONLY).**

**WRENCH**,  $\frac{5}{8}$ -in.

**WRENCH**, open-end,  $\frac{9}{16}$ -in.

**WRENCH**, open-end  $\frac{1}{2}$ -in.

**WRENCH**, open-end,  $\frac{5}{8}$ -in.

Mount fuel pump to carburetor tube main branch assembly on right side of No. 1 engine ( $\frac{5}{8}$ -in. wrench) (fig. 3). Select tube from connection to No. 5 engine and connect to right side of connection ( $\frac{5}{8}$ -in. open-end wrench). Mount distribution block and bracket on 2 cylinder head studs on No. 5 engine, directly above No. 4 carburetor ( $\frac{5}{8}$ -in. wrench). Connect line from branch connection to distribution block ( $\frac{5}{8}$ -in. open-end wrench). Connect flexible tubes from distribution block to both Nos. 4 and 5 carburetors ( $\frac{9}{16}$ -in. open-end wrench). Tighten all connections securely. Select fuel line, from branch connection to No. 1 carburetor. Place line in position, along right side of No. 1 cylinder head. Connect end to branch connection ( $\frac{1}{2}$ -in. open-end wrench). Connect flexible tube, which is attached to opposite end of tube, to No. 1 carburetor ( $\frac{9}{16}$ -in. open-end wrench). Tighten both connections securely. **NOTE:** Place line retaining clip over corner cylinder head stud on No. 1 engine, but do not install nut. Mount distribution block on upper side of No. 2 engine cylinder head, on third stud from distributor end (do not secure with nut). Place fuel line in position, from branch connection to distribution block, and connect at both ends ( $\frac{5}{8}$ -in. open-end wrench). Connect short flexible tube from distribution block (at end toward distributor) to No. 2 carburetor ( $\frac{9}{16}$ -in. open-end wrench). Connect metal tube to distribution block (at end toward radiator) ( $\frac{1}{2}$ -in. open-end wrench) and connect flexible tube, which is attached to opposite end of metal tube to No. 3 car-

## ASSEMBLY OF POWER UNIT

buretor ( $\frac{9}{16}$ -in. open-end wrench). Attach clip on metal line to No. 2 carburetor to intake manifold elbow mounting stud ( $\frac{9}{16}$ -in. open-end wrench).

### (41) INSTALL OIL FILTERS.

WRENCH, open-end,  $\frac{7}{16}$ -in.

WRENCH,  $\frac{5}{8}$ -in.

WRENCH,  $\frac{1}{2}$ -in.

Place oil filters and bracket assembly on 4 cylinder head studs on No. 1 engine and secure with nuts and pal nuts ( $\frac{5}{8}$ -in. wrench). Connect outlet tube to connection on drive gear case ( $\frac{7}{16}$ -in. open-end wrench). Tighten connections securely. Secure outlet tube to two No. 1 engine-to-crankcase hold-down cap screws (the cap screw heads being drilled and tapped to receive attaching cap screws ( $\frac{1}{2}$ -in. wrench) ).

### (42) INSTALL SPARK PLUG WIRING HARNESS.

WRENCH,  $\frac{5}{8}$ -in.

PLIERS, side-cutting

WRENCH,  $\frac{9}{16}$ -in.

SCREWDRIVER

Select the proper harness assembly and mount on respective cylinder head. Secure supporting brackets to cylinder head studs ( $\frac{5}{8}$ -in. wrench). Install brackets to support Nos. 5 and 6 spark plug wires on each engine ( $\frac{9}{16}$ -in. wrench) and place wires in position in these brackets. Install distributor caps on distributors and secure with 2 screws each (screwdriver). Lock screws with locking wires (side cutting pliers). NOTE: Be sure to check spark plug wires, to be sure they are installed correctly in distributor caps, as indicated by numerals, on both wires and caps. Connect all spark plug wires to plugs. Install heat deflectors on engines Nos. 2, 3, and 5, on the 4 end studs (at distributor end) on each cylinder head and secure with 4 nuts and pal nuts each ( $\frac{5}{8}$ -in. wrench).

### (43) INSTALL IGNITION COILS.

PLIERS, side-cutting

WRENCH,  $\frac{9}{16}$ -in.

WRENCH,  $\frac{3}{8}$ -in.

WRENCH, open-end,  $\frac{1}{2}$ -in.

WRENCH,  $\frac{1}{2}$ -in.

Select the proper coil and mount on respective bracket on end of each engine (distributor end). Secure with 2 nuts each ( $\frac{1}{2}$ -in. open-end wrench) and lock nuts with locking wire (side cutting pliers). Select proper coil primary wire and conduit from No. 1 to No. 2 coil; place it in position and attach one retaining clip to bolt on No. 1 engine timing gear case cover ( $\frac{1}{2}$ -in. wrench) and one clip to No. 2 engine water adapter mounting stud ( $\frac{9}{16}$ -in. wrench). Select proper wire and conduit from No. 2 coil to No. 3 coil, place in position, and attach upper end to No. 2 engine water adapter ( $\frac{9}{16}$ -in. wrench), one clip to No. 2 engine timing gear case cover attaching screw ( $\frac{1}{2}$ -in. wrench) and one clip to No. 3

**ORDNANCE MAINTENANCE — POWER UNIT FOR  
MEDIUM TANKS M3A4 AND M4A4**

engine timing gear case cover attaching screw ( $\frac{1}{2}$ -in. wrench). Select the proper wire and conduit from No. 1 to No. 5 coil and attach one clip to No. 1 engine timing gear case cover attaching screw ( $\frac{1}{2}$ -in. wrench) and one clip to No. 5 engine timing gear case cover attaching screw ( $\frac{1}{2}$ -in. wrench). Connect the other wire to coils Nos. 5 and 4, attaching clips to timing gear case cover attaching screws on No. 5 engine ( $\frac{1}{2}$ -in. wrench). Connect the primary wires (white with green tracer) to terminal post in center of end of coil. (It will be noted that on coils Nos. 1, 2 and 5, two wires will be connected to this post, while on coils Nos. 3 and 4, only one wire is attached to post.) Tighten terminal nuts securely and lock in place with pal nuts ( $\frac{3}{8}$ -in. wrench). Screw the knurled connections, which encircles the coil high tension wire, into opening in end of each coil. Connect the small black wire, from distributor, to terminal post adjacent to coil high tension terminal.

**(44) INSTALL BREATHER LINES.**

**PLIERS**, side-cutting

**WRENCH**,  $\frac{5}{8}$ -in.

**WRENCH**,  $\frac{1}{2}$ -in.

Place gasket in opening in upper side of No. 5 engine (at radiator end), place tube and elbow in opening, with other end of tube extending toward upper right corner of radiator, and secure with long bolt, through hole in elbow ( $\frac{1}{2}$ -in. wrench). Force rubber hose over free end of tube and secure with hose clamp. Lock clamp thumbscrew with locking wire (side cutting pliers). Place new gasket in opening in left side of No. 1 engine cylinder block, at radiator end, position dry breather tube along left side of No. 1 engine, with elbow in this opening. Secure to No. 1 engine with long bolt through hole in elbow ( $\frac{1}{2}$ -in. wrench). Place clip at free end of tube over end cylinder head stud of No. 1 engine. Place step in position on No. 1 engine cylinder head and secure with 4 cylinder head stud nuts and pal nuts ( $\frac{5}{8}$ -in. wrench).

**(45) INSTALL EXHAUST PIPES.**

**PLIERS**, side-cutting

**WRENCH**,  $\frac{5}{8}$ -in. (2)

**WRENCH**,  $\frac{7}{8}$ -in.

**WRENCH**, torque

Place pipe in position on No. 4 manifold and attach with 2 bolts, nuts and pal nuts. Tighten nuts to 40 to 50 foot-pounds (two  $\frac{5}{8}$ -in. wrenches). Place exhaust pipe in position on No. 4 manifold, and using connection, connect it to No. 4 exhaust pipe. Attach pipe to No. 5 manifold with 2 bolts, nuts and pal nuts (two  $\frac{5}{8}$ -in. wrenches). Tighten connection clamp bolt ( $\frac{7}{8}$ -in. wrench) and lock with cotter pin (side-cutting pliers). Connect exhaust pipe to No. 3 exhaust manifold, securing with 2 bolts, nuts and pal nuts. Tighten nuts to 40 to 50 foot-pounds (two  $\frac{5}{8}$ -in.

## ASSEMBLY OF POWER UNIT

wrenches). Locate pipe on No. 2 exhaust manifold, and with connection, connect it to No. 3 exhaust pipe. Secure to No. 2 manifold with 2 bolts, nuts and pal nuts. Tighten nuts to 40 to 50 foot-pounds (two  $\frac{5}{8}$ -in. wrenches). Tighten clamp bolt on connection and secure with cotter pin ( $\frac{7}{16}$ -in. wrench and side cutting pliers). Place lower end of No. 1 exhaust pipe in connection and attach pipe to No. 1 exhaust manifold with 2 bolts, nuts and pal nuts. Tighten nuts to 40 to 50 foot-pounds (two  $\frac{5}{8}$ -in. wrenches). Tighten clamp bolt on connection ( $\frac{7}{16}$ -in. wrench) and lock with pin (side cutting pliers).

## (46) INSTALL WATER OUTLET TUBES AND HOSE (fig. 3).

PLIERS, side-cutting

WRENCH, open-end,  $\frac{9}{16}$ -in.WRENCH,  $\frac{1}{2}$ -in.

(a) Position new gaskets on cylinder head adapters of engines Nos. 2 and 3. Install water outlet tube on No. 3 adapter, securing with 2 cap screws and lock washers ( $\frac{9}{16}$ -in. open-end wrench). Position new hose clamp on outlet tube and slide engine radiator inlet hose on end of tube. With new hose clamp on No. 2 engine cylinder water outlet elbow, insert end of elbow in hose and attach elbow to No. 2 engine adapter, securing with 2 cap screws and lock washers ( $\frac{9}{16}$ -in. open-end wrench). Position hose clamps on hose, at each end, tighten and lock in place with locking wires (side cutting pliers). Position new hose clamps on elbow and radiator inlet, left, and connect by installing hose on elbow and radiator inlet. Place hose clamps on hose, but do not tighten.

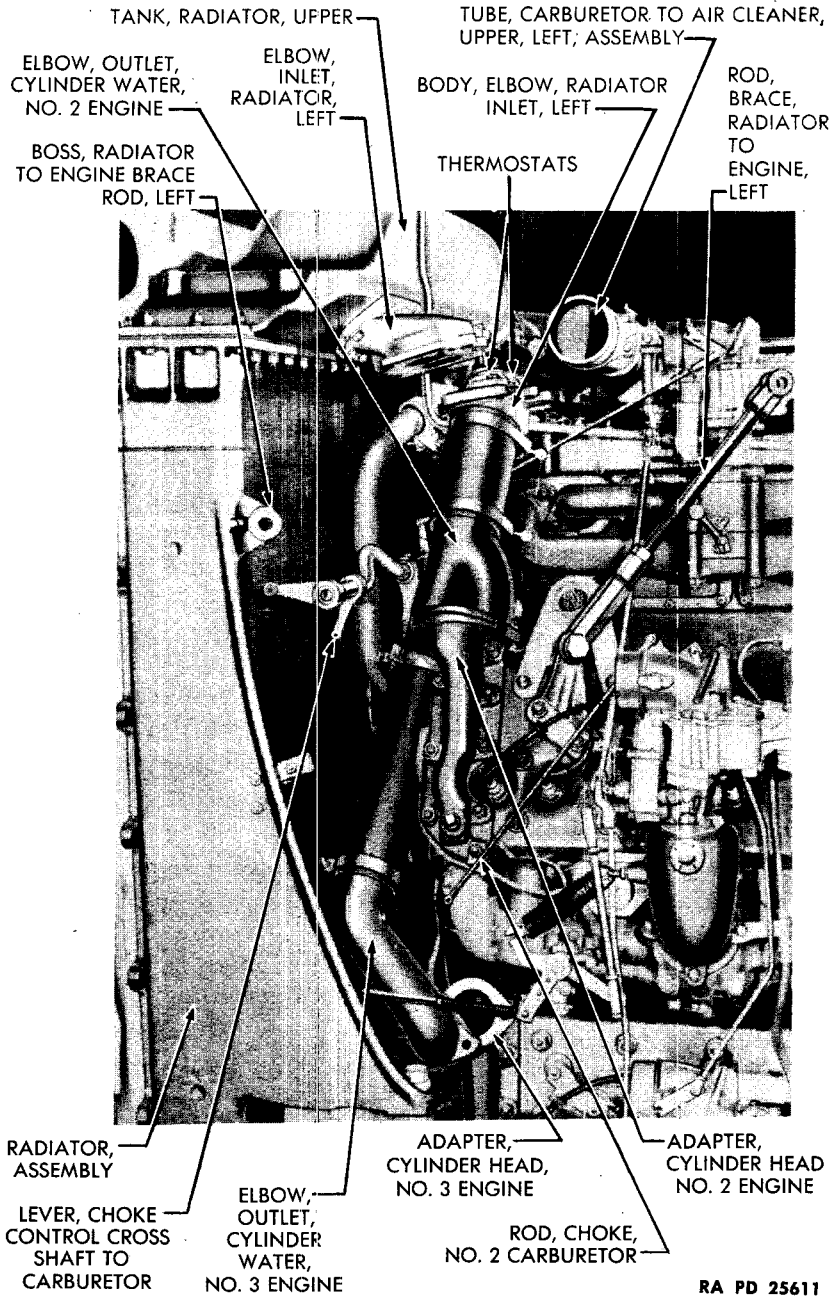
(b) On power units after serial No. M4A4-3211, remove 8 cap screws which attach elbow to left elbow body, separate elbow and body, and mount thermostats (2 in each unit) in openings provided ( $\frac{1}{2}$ -in. wrench) (fig. 196). Be sure the flange of thermostat rests in counterbore in elbow. Place new rubber gasket on thermostat (figs. 195 and 196). Position new gasket on elbow (with gasket over flange of thermostat) and assemble elbow and elbow body, securing with the 8 cap screws ( $\frac{1}{2}$ -in. wrench).

(c) Repeat the above operations to install tube, elbow, thermostats, hoses and inlet to engines Nos. 4 and 5.

(d) On power units after serial No. M4A4-3211, position new hoses and new hose clamps on bypass center tube assembly (total of 4 hoses) and connect tube between elbows right and left, connecting short tube to No. 1 engine cylinder head adapter. Tighten all hose clamp thumb-screws and lock with locking wires (side-cutting pliers).

(e) Position new hose clamps on No. 1 engine cylinder head adapter and connect hose to adapter and radiator center inlet (do not tighten hose clamps).

**ORDNANCE MAINTENANCE — POWER UNIT FOR  
MEDIUM TANKS M3A4 AND M4A4**



RA PD 25611

**Figure 195 — Power Unit-Left Side**

ASSEMBLY OF POWER UNIT

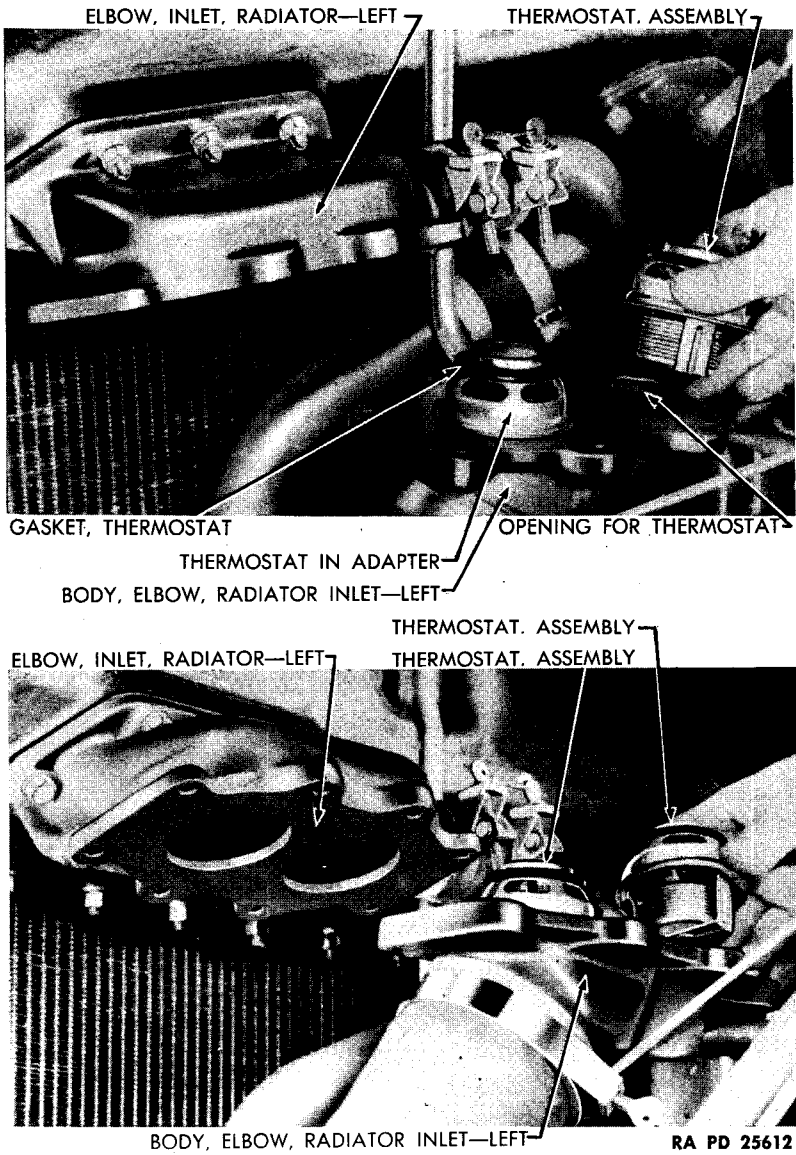


Figure 196 — Installing Bypass Type Thermostats

ORDNANCE MAINTENANCE — POWER UNIT FOR  
MEDIUM TANKS M3A4 AND M4A4

(47) INSTALL RADIATOR ASSEMBLY.

Follow instructions outlined in TM 9-754 (par. 90 e) to install radiator. Install radiator to engine brace rod bracket on No. 2 and No. 5 engine cylinder heads, securing with 2 nuts and lock washers each ( $\frac{9}{16}$ -in. wrench). After radiator has been installed, aline all hose clamps on water outlet tubes, tighten hose clamp thumbscrews and secure with locking wires.

(48) INSTALL RADIATOR OUTLET TUBES.

PLIERS, side-cutting

Using new hoses and new hose clamps, connect tubes to the inlet openings in water pumps. Tighten hose clamp thumbscrews and secure with locking wires. Connect bypass side-tube assembly to bypass center tube assembly and to left radiator outlet tube (after power unit serial No. M4A4-3211 only). On power units after serial No. M4A4-3211, connect radiator inlet bypass tube assembly to water pump inlet tube (fig. 197).

(49) INSTALL WATER PUMP AIR RELIEF TUBES (MULTIPLE WATER PUMP TUBE ONLY) (fig. 2).

SCREWDRIVER

WRENCH, open-end,  $\frac{11}{8}$ -in.

WRENCH,  $\frac{1}{2}$ -in.

WRENCH, open-end,  $\frac{3}{4}$ -in.

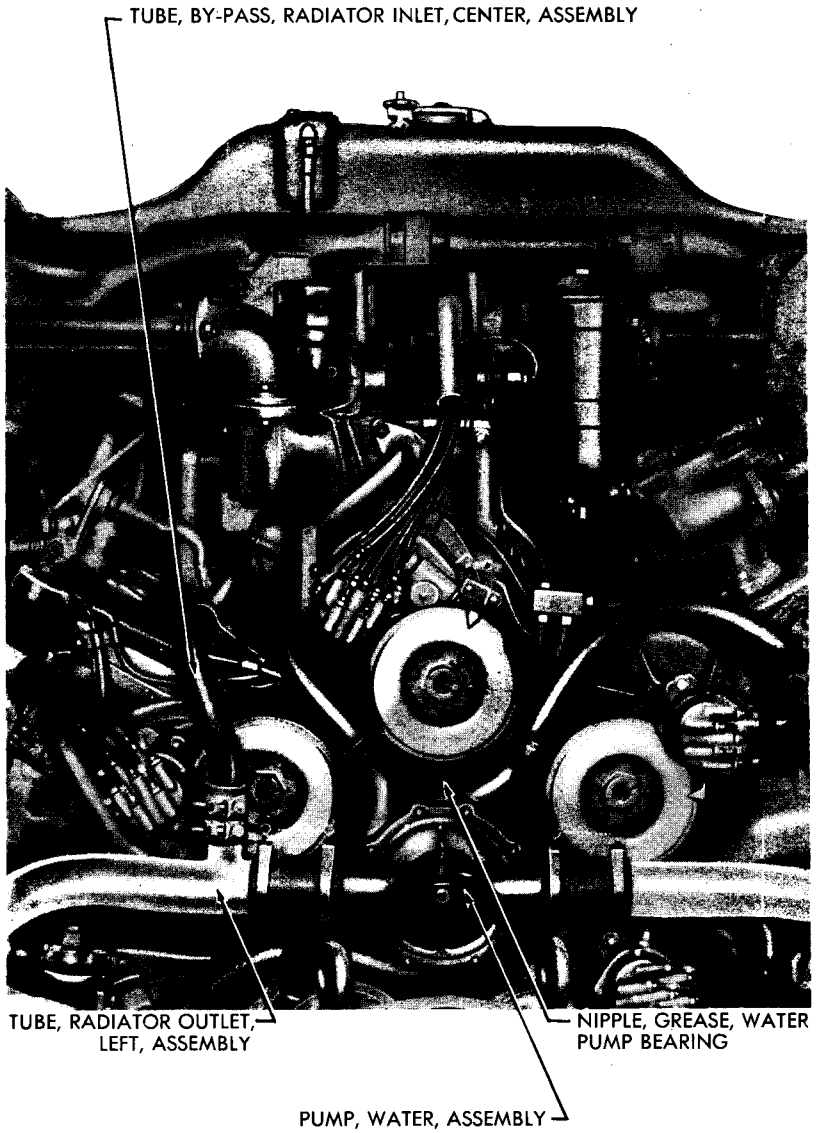
WRENCH, open-end,  $\frac{5}{8}$ -in.

WRENCH, socket,  $\frac{3}{8}$ -in.

(a) Install elbow connection in top of No. 4 water pump housing, with opening facing to right ( $\frac{11}{8}$ -in. open-end wrench). Install double outlet connection in top of No. 5 water pump housing, with the openings facing to left ( $\frac{3}{4}$ -in. open-end wrench). Install double outlet connection in top of No. 1 water pump housing, with openings facing right and left ( $\frac{11}{8}$ -in. open-end wrench). Install double outlet connection in top of No. 2 water pump housing, with outlets facing right and left ( $\frac{11}{8}$ -in. open-end wrench). Install nipple in top of No. 3 water pump body ( $\frac{3}{8}$ -in. socket wrench).

(b) Select the proper tube and connect to the connections on No. 4 and No. 5 water pumps. Tighten connections securely ( $\frac{5}{8}$ -in. open-end wrench). Select the proper tube and connect to the connections on No. 5 and No. 1 water pumps. Tighten connections securely ( $\frac{5}{8}$ -in. open-end wrench). Attach retaining clip to No. 5 timing gear case cover attaching screw ( $\frac{1}{2}$ -in. wrench). Select the proper tube and connect to the connections on No. 1 and No. 2 water pumps. Tighten connections securely ( $\frac{5}{8}$ -in. open-end wrench). Attach retaining clip to top of generator shield (screwdriver). Connect the remaining tube to connections on No. 2 and

ASSEMBLY OF POWER UNIT



RA PD 25586

**Figure 197 — Showing Bypass Tube Entering Radiator Outlet Tube Assembly.**



**ORDNANCE MAINTENANCE – POWER UNIT FOR  
MEDIUM TANKS M3A4 AND M4A4**

No. 3 water pumps. Tighten connections securely ( $\frac{5}{8}$ -in. open-end wrench).

(50 **INSTALL CARBURETOR THROTTLE CONTROL BELL CRANK** (fig. 8).

**WRENCH**, open-end,  $\frac{1}{2}$ -in.

Position bell crank bracket on No. 2 engine intake manifold and secure with 2 cap screws and washers.

(51) **SET POWER UNIT IDLING SPEED.**

Mount power unit on test stand and test, as outlined in paragraph 26. Connect carburetor choke control rods as outlined in TM 9-754, paragraph 73. Connect carburetor throttle rods as outlined in TM 9-754, paragraph 72.

Section IX

**ADJUSTMENTS AND TESTS BEFORE INSTALLATION**

	Paragraph
General .....	26
Equipment required for dynamometer test.....	27
Performance tests .....	28
Final adjustment and assembly.....	29

**26. GENERAL.**

a. After a power unit has been repaired or rebuilt by ordnance personnel, it must be tested before installation in the vehicle or before it is returned to the using arms, to insure that it is operating properly. Test the power unit under actual load conditions with a dynamometer, with power unit mounted on test stand. The following procedure describes the run-in, dynamometer power test and final adjustments for the power unit. All power units must conform to the requirements before being approved.

**27. EQUIPMENT REQUIRED FOR DYNAMOMETER TEST.**

a. The following equipment must be obtained and the proper installations made before these tests can be conducted:

- (1) Dynamometer with appropriate stand for mounting power unit.
- (2) Instrument panel with the following instruments mounted and wired according to wiring diagram (fig. 198):
  - (a) Circuit breakers, one 15-ampere, one 10-ampere.
  - (b) Resistors.
  - (c) Five exhaust stack temperature warning indicators.
  - (d) High water temperature warning indicator.
  - (e) Water temperature gage.
  - (f) Water temperature gage selector switch.
  - (g) Oil pressure gage.
  - (h) Low oil pressure warning indicator.
  - (i) Oil temperature gage.
  - (j) Ignition switch.
  - (k) Starter switch.
  - (l) Master battery switch.
  - (m) Starter solenoid switch.
  - (n) Ignition solenoid switch.

ORDNANCE MAINTENANCE – POWER UNIT FOR  
MEDIUM TANKS M3A4 AND M4A4

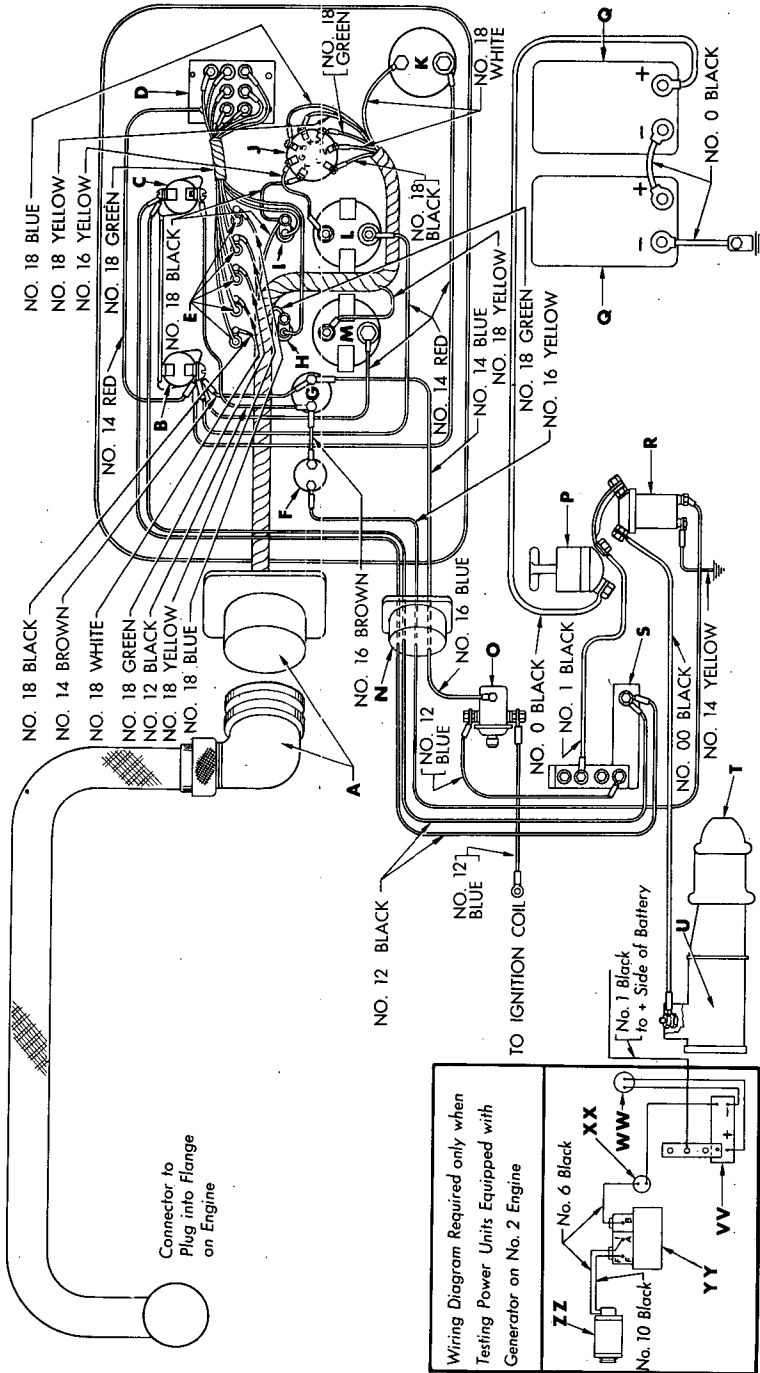


Figure 198 — Wiring Diagram For Test Procedure

ADJUSTMENTS AND TESTS BEFORE INSTALLATION

- E** LIGHTS, EXHAUST STACK TEMP. WARNING
- F** SWITCH, STARTER, ASS'Y
- G** SWITCH, IGNITION, ASS'Y
- H** INDICATOR, LOW OIL PRESSURE
- I** INDICATOR, HIGH WATER TEMP.
- J** SWITCH, SELECTOR, WATER TEMP.
- K** GAGE, OIL TEMP. ASS'Y
- L** GAGE, WATER TEMP. ASS'Y
- M** GAGE, OIL PRESSURE, ASS'Y
- O** SWITCH, SOLENOID, BATTERY BOX IGNITION COIL
- P** SWITCH, BATTERY BOX MASTER, ASS'Y
- Q** BATTERY 12 VOLT
- R** SWITCH, SOLENOID, BATTERY BOX STARTER
- S** SHUNT, AMMETER
- T** MOTOR, STARTER, ASS'Y
- U** STARTER
- V** SHUNT, AMMETER
- W** AMMETER

**31 CONTACT CONNECTOR - COLOR CODE**

LETTER ON FLANGE	SIZE	COLOR
A	18	BLUE
B	18	YELLOW
C	18	WHITE
D	18	BLACK
E	18	GREEN
F	18	BLUE
G	18	YELLOW
H	18	WHITE
I	18	BLACK
J	18	GREEN
K	18	YELLOW
L	18	WHITE
M	18	BLACK
N	18	GREEN

**6 CONTACT CONNECTOR - COLOR CODE**

LETTER ON FLANGE	SIZE	COLOR
B	12	BLACK
E	12	BLACK
C	16	YELLOW
D	14	BLUE

- B** CIRCUIT BREAKER, INSTRUMENTS (10 AMPERES)
- C** CIRCUIT BREAKER, ACCESSORY (15 AMPS.)
- D** RESISTORS
- XX** CIRCUIT BREAKER, 60 AMP.
- YY** REGULATOR, GENERATOR
- ZZ** GENERATOR, ASS'Y

RA PD 25251B

Legend For Figure 198 - Wiring Diagram For Test Procedure

## ORDNANCE MAINTENANCE — POWER UNIT FOR MEDIUM TANKS M3A4 AND M4A4

- (o) Battery box shunt.
- (p) Two 12-volt batteries.
- (q) Thirty-one contact connectors.
- (r) Six contact connectors.

**NOTE:** In addition to the above electrical equipment, the following items will be necessary if a power unit, with multiple water pumps, is to be checked, due to the generator which is mounted on power units equipped with multiple pumps (fig. 198).

- (a) Generator regulator.
- (b) Circuit breaker, 60-ampere.
- (c) Ammeter.
- (d) Ammeter shunt.

(3) Five vacuum checking gages MTM-A4-30. These are to check manifold vacuum and are used when setting the idle speed and adjusting the carburetor governors.

(4) A tachometer mounted with the vacuum gages. **NOTE:** Connect tachometer with drive located in timing gear case cover on No. 1 engine. All revolution-per-minute figures are crankshaft speeds. If dynamometer is equipped with tachometer giving engine driven gear shaft speed, correct all engine speeds by dividing by 1.19 (this is the ratio between crankshaft and engine driven gear shaft speed).

(5) A water supply tank must be available which can be controlled in such a manner that when power unit is operating the water temperature of the power unit is held between 145-175 degrees F.

(6) An oil supply tank of at least 10-gallon capacity and capable of maintaining an oil temperature, with power unit operating, of 160-200 degrees F.

(7) A suitable fuel supply tank must also be available.

### 28. PERFORMANCE TESTS.

#### a. Run-in.

**GAGE**, compression pressure,

Federal stock No. 41-G-124

**HOIST**, 4-ton capacity

**SLING**, engine assembly hoist,

MTM-A4-18

**TESTER**, spark plug (neon)

**WRENCH**, thin wall,

deep socket,  $\frac{1}{8}$ -in.

(1) Mount power unit on dynamometer stand using sling MTM-A4-18 (fig. 202) and 4-ton hoist.

**ADJUSTMENTS AND TESTS BEFORE INSTALLATION**

(2) Connect water supply tank to power unit at the 2 radiator outlet assemblies (right and left) and the 3 radiator inlet adapters. Connect oil supply tank to power unit at engine-to-oil-cooler hose and engine-to-oil-tank hose on right side of crankcase (fig. 147). Connect fuel supply tank to inlet side of fuel pump.

(3) **POWER UNIT RUN-IN SCHEDULE:** Start power unit and operate as outlined in the following schedule. **CAUTION:** During first few minutes of operation, attention should be given to any unusual noises which might indicate looseness in bearings, gears, etc. If power unit does not operate smoothly, refer to paragraphs 11, 12 and 13.

REVOLUTIONS PER MINUTE	TORQUE LOAD Pound-foot	TIME Hours
800 .....	(no load)	1/4
1,000 .....	225	1
1,400 .....	275	1
1,600 .....	325	1
1,800 .....	375	1
2,000 .....	425	1
2,200 .....	475	1
2,400 .....	525	1
2,600 .....	575	1
2,800 .....	625	1
2,800 .....	780	1
		10 1/4 hours, total

(4) **CHECK WATER AND OIL TEMPERATURES.**

The water temperature must be held to 145-175 F and the oil temperature to 160-200 F.

(5) **CHECK COMPRESSION PRESSURE (fig. 199).**

**GAGE**, compression pressure, **WRENCH**, thin wall, deep  
Federal Stock No. 41-G-124 socket, 1 1/8-in.

With power unit warmed up, remove all 30 spark plugs (1 1/8-in. thin wall, deep socket wrench) and crank power unit at 110 revolutions per minute. Use compression pressure gage Federal stock No. 41-G-124 and check compression of each cylinder. Compression pressure should not be lower than 90 pounds per square inch. If any cylinders are found that have a lower pressure it is an indication that the valves, piston or rings are not properly installed. Correct the trouble before proceeding to power test.

ORDNANCE MAINTENANCE — POWER UNIT FOR  
MEDIUM TANKS M3A4 AND M4A4

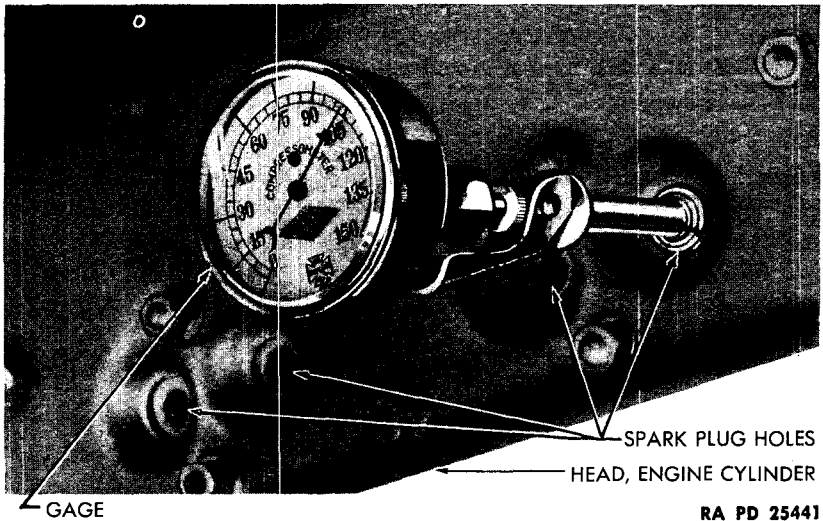


Figure 199 — Checking Engine Compression

(6) ADJUST THROTTLE RODS.

During the no-load part of the run-in, adjust the throttle rods to bring the manifold vacuum of all 5 engines within a maximum spread of 5-inch mercury. This is an approximate setting to be sure all engines are pulling approximately the same during the run-in. Before the power test is run, a more thorough check is made (par. 28 b (6) ). It is necessary to wait until after the complete run-in, before making the comprehensive idle check so that the power unit will be thoroughly warmed up.

(7) SPARK PLUGS.

TESTER, spark plug (neon)

Check all 30 spark plugs with a neon tester. Any defective plugs must be replaced. Correct gap is 0.024-inch to 0.027-inch.

b. Adjustments Preliminary To Power Test.

GAGE, hydraulic

GAGE, vacuum checking,

MTM-A4-30 (5)

LAMP, test, neon

PLIERS, side-cutting

SCREWDRIVER

TOOL, adjusting

TOOL, sealing

WRENCH, open-end,  $\frac{3}{8}$ -in.

WRENCH, open-end,  $\frac{7}{8}$ -in.

(1) POWER UNIT IDLE. During the following tests do not allow the power unit to idle continuously (750 rpm) for longer than five minutes. If it is necessary to idle for a longer period, adjust throttle to 950-1,000

## ADJUSTMENTS AND TESTS BEFORE INSTALLATION

revolutions per minute. Continuous operation at idle speed of 750 revolutions per minute will shorten the useful life of unit by causing increased wear and overheating.

### (2) CHECK THE IGNITION TIMING OF EACH ENGINE WITH NEON TEST LAMP.

#### LAMP, test (neon)

Connect test lamp high-tension lead to spark plug terminal of the No. 1 spark plug of engine being checked. Connect test lamp low-tension lead to No. 4 coil resistor (to which No. 12 blue wire is attached). Connect ground lead of test lamp to ground. Point timing lamp in direction of vibration damper. Operate power unit at 1,300 revolutions per minute. At this speed, timing pointer mounted adjacent to vibration damper (fig. 208) should read 14 degrees (plus or minus one degree) before top dead center on the markings on vibration damper labeled "IGN." If timing is not correct, reset, and recheck with neon test lamp.

### (3) CHECK THE PHASING OF THE INDIVIDUAL ENGINES AS FOLLOWS:

#### LAMP, test (neon)

Connect test lamp high-tension lead to spark plug terminal of No. 1 spark plug of No. 1 engine. Connect test lamp low-tension lead to No. 4 coil resistor (to which No. 12 blue wire is attached). Connect ground lead of test lamp to ground. Point test lamp toward vibration damper of No. 1 engine. Operate power unit at 1,300 revolutions per minute. Timing will be shown in the set of degree marks on vibration damper marked No. 1. Point test lamp toward damper on No. 2 engine. The ignition pointer should show the same spark advance but be located in the set of marks for No. 2 engine. Check the remaining individual engines in the same manner. Each should show the same spark advance but in the set of degree marks for that particular engine. If any engine fails to show the correct spark advance with respect to its own set of marks, it indicates that the engine is not correctly geared to the engine-driven gear shaft and must be changed. This can be accomplished by removing housing from power unit and following synchronizing procedure as outlined in paragraph 25 b. (17).

### (4) MANIFOLD HEAT CONTROL VALVES.

Check the manifold heat control valves for freedom from sticking. If the heat control valve is stuck or inoperative, repair or replace valve.

### (5) WATER PUMP BELTS (MULTIPLE WATER PUMP TYPE ONLY).

Adjust all water pump belts to 1/2-inch to 5/8-inch deflection (measured at equal distances between the drive and driven pulleys) with a



## ORDNANCE MAINTENANCE — POWER UNIT FOR MEDIUM TANKS M3A4 AND M4A4

10-pound load. They should not be stretched too tightly. All belts are adjusted by changing the effective diameter of the water pump pulley; after this adjustment, the generator should be checked for fore-and-aft pulley alinement, and corrected if necessary.

### (6) IDLE ADJUSTMENT.

GAGE, vacuum, checking,

MTM-A4-30 (5)

PLIERS, side-cutting

SCREWDRIVER

WRENCH, open-end,  $\frac{3}{16}$ -in.

WRENCH, open-end,  $\frac{7}{16}$ -in.

Make the idle adjustments as follows:

- (a) Power unit warmed up.
- (b) Remove throttle rods (side-cutting pliers). Use springs to hold each throttle rod shaft to idle stop.
- (c) Install vacuum gage in each engine by removing brass plug from top of each intake manifold, toward distributor end ( $\frac{7}{16}$ -in. open-end wrench), and screw a gage into each opening.
- (d) If speed is below 750 revolutions per minute, open throttle stop screw (screwdriver and  $\frac{3}{16}$ -in. open-end wrench), on those carburetors showing high vacuum.
- (e) If speed is above 750 revolutions per minute, close the throttle stop screw (screwdriver and  $\frac{3}{16}$ -in. open-end wrench) on those carburetors showing low vacuum.
- (f) When all vacuum readings are within 1-inch mercury spread, carburetors are equalized at idle.
- (g) If carburetors are equalized and speed is below 750 revolutions per minute, open all stop screws until proper speed is reached, keeping vacuum spread to 1-inch mercury. NOTE: Always check after tightening throttle stop screw lock nuts.
- (h) After carburetors are equalized at 750 revolutions per minute, install throttle rods.

### (7) FUEL PUMP PRESSURE.

GAGE, hydraulic

Check the fuel pump pressure with hydraulic gage. At 1,000 revolutions per minute (part load), the pressure should be from 4 to 6 pounds per square inch. At 2,600 revolutions per minute (wide open throttle), the pressure should be 4½ to 6½ pounds per square inch.

### (8) CHECK GOVERNOR SPEED SETTING.

GAGE, vacuum checking, MTM-A4-30 (5)

To determine governor performance, run the power unit at wide open

## ADJUSTMENTS AND TESTS BEFORE INSTALLATION

throttle and gradually increase engine speed by reducing the dynamometer load until a speed of 2,400 revolutions per minute has been reached. The 5 vacuum gages should give a gradual increase in vacuum. At 2,600 revolutions per minute, no gage should read higher than 3-inch of mercury. Increase the speed to 3,100 revolutions per minute. The manifold vacuums should rise sharply but not necessarily together until at 3,100 revolutions per minute all 5 gages should show at least 15-inch of mercury.

### (9) CHANGE GOVERNOR SPEED SETTING.

GAGE, vacuum, reading,

MTM-A4-30 (5)

PLIERS, side-cutting

SCREWDRIVER, (special)

governor adjusting (Carter)

TOOL, sealing

WRENCH, (special), governor  
adjusting (Carter)

(a) To adjust the governor, stop the power unit and remove lock wire and seal (side-cutting pliers) from the cap on the adjusting well and pull cap off with fingers. Loosen the lock nut counterclockwise with the special hollow wrench while holding the adjusting screw stationary with the special screwdriver inserted through the special wrench. **CAUTION:** Do not remove the lock nut from the adjusting screw. Turn the adjusting screw with the screwdriver counterclockwise to lower the vacuum, or clockwise to raise the vacuum. Tighten the lock nut after each change in setting. One full turn of the screw will change the set speed about 400 revolutions per minute. This means that, if the manifold vacuum reading is 3-inch of mercury at 2,200 revolutions per minute and the adjusting screw is turned one revolution counterclockwise, the speed should rise to about 2,600 revolutions per minute before the manifold vacuum once again rises to 3-inch of mercury.

(b) Similarly, if the vacuum gage corresponding to a certain governor does not show 15-inch vacuum until the engine speed reaches 3,300 revolutions per minute, bring this governor within requirements by turning the adjusting screw clockwise half a turn.

(c) If readjustment of the governor speed setting is necessary because at 2,600 revolutions per minute the manifold vacuum is 6-inch instead of the permissible 3-inch, one method of proceeding would be to find out at what speed the manifold vacuum is 3-inch and then to provide for a higher speed setting as outlined in the preceding paragraph. The other method of proceeding would be by trial and error; bring the engine up to 2,600 revolutions per minute after each trial adjustment to see whether the manifold vacuum has yet fallen below the desired value (3-in.). This trial and error procedure is generally the only one that can be used when readjustment becomes necessary because at 3,100 revolutions per

**ORDNANCE MAINTENANCE – POWER UNIT FOR  
MEDIUM TANKS M3A4 AND M4A4**

minute a governor provides a manifold vacuum of less than the desired minimum of 15-inch. If only one or two governors of the five show such need for readjustment, it will usually be impossible to increase engine speed sufficiently to find out at what speed those governors will provide 15-inch.

(d) It should be understood and kept in mind that a speed adjustment that reduces manifold vacuum from 6- to 7-inch of mercury to the desired 3-inch at 2,600 revolutions per minute will also tend to lower the vacuum obtained at 3,100 revolutions per minute. Similarly, the change in speed adjustment that raised the manifold vacuum from 12-inch to the desired 15-inch at 3,100 revolutions per minute will also raise the manifold vacuum at 2,600 revolutions per minute. Therefore, after each change in speed setting, the vacuum readings should be rechecked at both 2,600 and 3,100 revolutions per minute.

(e) It follows from the above observation that a governor providing too high a manifold vacuum at 2,600 revolutions per minute, and yet too low a vacuum at 3,100 revolutions per minute, cannot by any change in speed adjustment be made to meet all requirements. Such a governor must be rejected and replaced. For all phases of governor performance checking, including observation of speed setting, the manual throttle control (foot throttle or hand throttle control) is to be held in wide open or full throttle position.

**(10) OIL PRESSURE.**

Check the oil pressure with OIL, engine, SAE 10, at approximately 160 F. The following pressure limits must be maintained:

Revolutions Per Minute	Pressure Limits
750.....	15 to 65 lb per sq. in.
1,400.....	30 to 65 lb per sq. in.
2,850.....	30 to 65 lb per sq. in.

**c. Power Test (Dynamometer).**

**(1) SPEED AND NUMBER OF RUNS.**

The power test consists of a series of runs at wide open throttle at 750, 1,400, 2,200, 2,500, 2,600 and 2,900 revolutions per minute.

**(2) DURATION OF RUNS.**

The power test must not be started until the power unit has been warmed up to the specified oil and water temperature. Make each power run 5 minutes long, and the 6 runs are to progress continuously.

## ADJUSTMENTS AND TESTS BEFORE INSTALLATION

### (3) TEMPERATURES.

The water temperature measured at the top of each cylinder head must be maintained at 145 F-175 F. The 5 cylinder head temperatures must not differ from each other by more than 15 F. The temperature of the oil leaving the scavenger pump must be maintained at 160 F-200 F.

### (4) DYNAMOMETER LOAD — SCALE READING.

The dynamometer scale must be calibrated at least once a week over the range used in power tests. The scale reading recorded shall be taken as an average steady value obtained during the last minute of the 5-minute run.

### (5) OIL PRESSURE.

Record the oil pressure for each run.

### (6) MANIFOLD VACUUM.

Care must be taken to keep the vacuum lines free from condensation and air leaks. Check the gages periodically with a mercury manometer.

### (7) MINIMUM OUTPUT REQUIREMENT.

(a) Every power unit must develop the following corrected brake horsepower and torque.

(b) Horsepower (corrected), 410 at 2,600 revolutions per minute.

(c) Maximum torque (corrected), 1,065 pounds-foot.

### (8) LEAKS.

Any oil, gasoline or water leaks must be carefully noted during the run-in and power test. At 2,900 revolutions per minute inspect the engine carefully for water leaks. All leaks must be corrected before the dynamometer test is completed.

## 29. FINAL ADJUSTMENTS AND ASSEMBLY.

HOIST, 4-ton capacity

WRENCH, socket,  $\frac{9}{16}$ -in.

PLIERS, side-cutting

WRENCH, socket, 1  $\frac{1}{8}$ -in.

SLING, engine assembly hoist,

MTM-A4-18

**NOTE:** The following procedure is to be carried out only if the power unit is to be installed in the vehicle at once and is not to be shipped. For packing and shipping instructions, refer to paragraphs 39, 40 and 41.

#### a. Inspection.

(1) Disconnect power unit from dynamometer.

(2) Install radiator (refer to TM 9-754, par. 90 c).

(3) Install clutch (refer to TM 9-754, par. 94 a).

(4) Fill cooling system with water.

**ORDNANCE MAINTENANCE — POWER UNIT FOR  
MEDIUM TANKS M3A4 AND M4A4**

(5) Operate power unit at 1,200 revolutions per minute idle speed for 15 minutes and examine for gasoline, water or oil leaks. In addition, the power unit must be run against the governor for a brief period and checked for leaks.

**b. Remove Power Unit From Dynamometer Stand.**

HOIST, 4-ton capacity

WRENCH, socket,  $\frac{9}{16}$ -in.

PLIERS, side-cutting

WRENCH, socket,  $1\frac{1}{8}$ -in.

SLING, engine assembly hoist,

MTM-A4-18

(1) Shut off fuel supply and run carburetors dry. Remove fuel supply line from intake side of pump.

(2) Drain oil system by removing drain plug in oil pan ( $1\frac{1}{8}$ -in. socket wrench). Install drain plug and tighten. Remove oil supply lines.

(3) Remove lock wires from cap screws holding oil pan with side-cutting pliers and remove the 26 cap screws with a  $\frac{9}{16}$ -inch socket wrench. Remove oil pan for inspection and clean thoroughly before reinstalling. Position new gasket and install oil pan in position. Secure with 26 cap screws and tighten with  $\frac{9}{16}$ -inch socket wrench. Install lock wire through heads of cap screws and twist end of wires together (side-cutting pliers).

(4) Disconnect power unit from permanent electrical wiring and remove from dynamometer stand with Sling MTM-A4-18 and 4-ton hoist (fig. 202).

Section X

**INSTALLATION**

	Paragraph
Installation of power unit.....	30

**30. INSTALLATION OF POWER UNIT.**

- a. Refer to TM 9-754, paragraph 53.

ORDNANCE MAINTENANCE — POWER UNIT FOR  
MEDIUM TANKS M3A4 AND M4A4

Section XI

LIMITS AND TOLERANCES

Limits and tolerances .....	31
Standard for tightening bolts .....	32

31. LIMITS AND TOLERANCES.

a. The "minimum" and "maximum" dimensions and clearances given below are production limits which should be held when a unit is being re-conditioned. The "replace beyond" column lists the maximum dimension or clearance beyond which a part must be replaced or reworked. If no figure is shown in the "replace beyond" column, the "maximum" or "minimum" dimensions must be held at all times.

b. Camshaft.

Journal diameter:

	Minimum	Maximum	Replace Beyond
No. 1 .....	1.998	1.999	1.996
No. 2 .....	1.9665	1.9675	1.9645
No. 3 .....	1.935	1.936	1.933
No. 4 .....	1.2475	1.2485	1.2455
Clearance between bearing and journal			
No. 1 .....	0.001	0.003	0.004
Nos. 2, 3, 4 .....	0.0015	0.0035	0.004
Bearing Run-Out .....			0.0015
End-play .....	0.002	0.006	0.010

c. Connecting Rods.

Twist or bend .....			0.0025
End-play on lower bearings .....	0.0055	0.011	0.011
Weight variation per set .....			¼ oz

d. Crankshaft And Bearings.

Crank pin, diameter .....	2.1236	2.1246	2.1216
Out-of-round .....			0.001
Taper .....			0.001

LIMITS AND TOLERANCES

	Minimum	Maximum	Replace Beyond
Clearance between bearing and pin.....	0.0005	0.0020	0.0025
<b>Main bearing journal</b>			
Diameter .....	2.4992	2.5002	2.4972
Out-of-round .....			0.001
Taper .....			0.001
Clearance between bearing and journal..	0.0005	0.0020	0.0035
Crankshaft end-play .....	0.003	0.007	0.010
Crankshaft run-out .....			0.002
<b>e. Cylinders.</b>			
Taper .....			0.020
Out-of-round .....			0.005
Conditioning working limits .....		0.0005	
<b>f. Pistons.</b>			
Clearance—top land .....	0.032	0.035	
Clearance—(between high spot or thrust face of piston skirt, 1/4-in. from bottom of piston) .....	0.0018	0.0024	
Taper of piston skirt .....	0.001	0.0015	
Skirt clearance with feeler, thrust side, with 0.003-in. x 1/2- in. feeler (U-slot)	5 lb	8 lb	
Variation per set .....			1/4 oz
<b>g. Piston Pins.</b>			
Diameter .....	0.8591	0.8593	0.8586
Fit in bushing .....	(Tight thumb push fit at normal room temperature (70-75 degrees) ).		
Fit in piston .....	Tight thumb push fit at 160 degrees F.		
<b>h. Piston Rings.</b>			
Gap between ends .....	0.007	0.015	0.030
Clearance in piston groove			
Compression ring .....	0.002	0.004	0.008
Oil ring .....	0.001	0.002	0.004



ORDNANCE MAINTENANCE — POWER UNIT FOR  
MEDIUM TANKS M3A4 AND M4A4

**i. Tappets.**

	Minimum	Maximum	Replace Beyond
Stem diameter .....	0.6235	0.6240	0.6225
Clearance .....	0.000	0.001	0.002
(Test clearance with dial indicator)			

**j. Camshaft Timing Gears.**

Backlash .....	0.002	0.004	
----------------	-------	-------	--

**k. Valves, Exhaust.**

Stem diameter .....	0.3385	0.3395	0.3365
Clearance between stem and guide.....	0.003	0.005	0.007
Clearance between stem and tappet (cold) .....		0.014	
Seat width .....		0.125	
Seat eccentricity (total indicator read- ing) .....		0.0015	
Top of cylinder block to top of valve guide .....	0.875	0.875	

NOTE: Check clearance with dial indicator attached to one of the cylinder head studs. Raise valve  $\frac{5}{16}$  inch above top of cylinder block and adjust dial indicator to register play of valve stem in guide. Clearance will be one-half of dial indicator reading.

**l. Valves, Intake.**

Stem diameter .....	0.3404	0.3415	0.3384
Clearance between stem and guide.....	0.001	0.003	0.005
Clearance between stem and tappet (cold) .....		0.010	
Seat width .....		0.125	
Seat eccentricity (total indicator read- ing) .....		0.0015	
Top of cylinder block to top of valve guide .....	0.875	0.875	

NOTE: Check clearance with dial indicator attached to one of the cylinder head studs. Raise valve  $\frac{5}{16}$  inch above top of cylinder block and adjust dial indicator to register play of valve stem in guide. Clearance will be one-half of dial indicator reading.

LIMITS AND TOLERANCES

m. Valve Springs.

	Minimum	Maximum	Replace Beyond
Spring pressure, compressed to 1 $\frac{3}{4}$ in. (valve closed) .....	40	45	
Compressed to 1 $\frac{3}{8}$ in. (valve open).....	107	115	

n. Water Pump (multiple or single type).

Clearance between impeller and pump body .....		0.095	
Seal thrust spring compressed to $\frac{9}{32}$ in....		(Outside diameter 1 $\frac{1}{2}$ -in.)	

o. Drive Gear Case.

Backlash between drive gears and driven gear .....	0.003	0.006	
Clearance between drive gear shaft and housing (press fit) .....	0.0005	0.0015	
Clearance between driven gear and shaft (press fit) .....	0.0005	0.0015	
Clearance between bearing and cover (press fit) .....	0.0002	0.0018	

p. Accessory Shaft.

End play .....	0.001	0.002	
Oil pump drive gear backlash.....	0.005	0.008	0.010
Oil pump drive shaft end play.....	0.002	0.004	

q. Distributor.

Backlash in gears.....	0.015	0.020	
------------------------	-------	-------	--

32. STANDARD FOR TIGHTENING BOLTS.

	TORQUE TIGHTNESS	
	Min.	Max.
Accessory drive shaft support screws .....	30	35
Connecting rod cap nuts .....	45	50
Crankshaft-driven clutch bolts .....	55	60
Crankcase ventilator pipe elbow screw.....	15	20
Crankcase ventilator hole cover screws.....	15	20
Cylinder block to crankcase screw .....	40	45
Cylinder head stud nuts—hot .....	60	65

ORDNANCE MAINTENANCE — POWER UNIT FOR  
MEDIUM TANKS M3A4 AND M4A4

	TORQUE TIGHTNESS	
	Min.	Max.
Cylinder head adapter stud nuts .....	25	30
Cylinder head half nuts .....	25	30
Cylinder head pal nuts .....	Finger-tight and $\frac{1}{3}$ turn	
Cylinder water outlet elbow screws .....	30	35
Engine drive gear housing to crankcase stud nuts .....	110	120
Engine drive gear housing to crankcase screw, large .....	55	60
Engine drive gear housing to crankcase screw, small .....	30	35
Engine drive gear housing to cylinder block screw, small .....	30	35
Engine drive gear housing to cylinder block screw, large .....	40	45
Engine drive gear clutch bolts .....	55	60
Engine drive gear shaft nuts .....	400	450
Exhaust pipe flange bolts .....	45	50
Gear case cover plate screws .....	12	17
Gear case cover screws .....	12	17
Intake to exhaust manifold bolt nuts .....	35	40
Intake manifold to elbow stud nuts .....	35	40
Main bearing cap screws .....	80	85
Manifold stud nuts .....	15	20
Starting jaw nut .....	108	
Valve spring cover screws .....	15	20
Vibration damper flange screws .....	15	20

Section XII

**SPECIAL ENGINE TOOLS**

Tools .....	Paragraph 33
-------------	-----------------

**33. TOOLS.**

	Manufacturer's Tool No.
BOLT, eye, lifting engine compartment top plate (2 required) .....	MTM-M3-497
DRIFT, drive gear roller bearing removing and installing .....	MTM-A4-42
DRIFT, main drive shaft front bearing installing .....	MTM-A4-14
DRIVER, drive gear stub .....	MTM-A4-43
DRIVER, gear box main drive gear and bearing .....	MTM-A4-45
GAGE, indicator and setting master gage drive gear .....	MTM-A4-19
GAGE, vacuum checking .....	MTM-A4-30
HANDLE, wrench, for A4-1, A4-25, A4-33 .....	MTM-A4-24
LOCK, main shaft, used when timing drive gears .....	MTM-A4-34
PILOT, pins, engine to crankcase installing (set of 2) .....	MTM-A4-23
PLATE, engine synchronizing .....	MTM-A4-46
PLATE, pair, engine lifting .....	MTM-A4-36
PULLER, clutch ball bearings .....	MTM-A4-35
PULLER, clutch hub (also fitted with hoist hook for lifting clutch) .....	MTM-A4-4
PULLER, water pump outer flange .....	MTM-A4-47
REMOVER AND REPLACER, cam shaft bearing .....	MTM-C-536
REPLACER, water pump shaft seal installing .....	MTM-C-528
SLING, engine assembly hoist .....	MTM-A4-18
SLING, power unit radiator lifting .....	MTM-A4-31
SPACER, accessory drive shaft bevel gear setting .....	MTM-A4-21
STAND, engine overhaul .....	MTM-A4-29
TOOL, drive gear alining .....	MTM-A4-39
TOOL, engine turning .....	MTM-A4-25
WRENCH, box socket, fuel pump housing cap screw .....	MTM-A4-6
WRENCH (WITH EXTENSION), lower engine-block-to-main-crankcase attaching cap screws, and engine-block-to-drive-gear-housing attaching cap screws (includes one 5/8-in. and one 1 9/16-in. hexagonal universal socket fitted with lock screws) .....	MTM-A4-11

ORDNANCE MAINTENANCE – POWER UNIT FOR  
MEDIUM TANKS M3A4 AND M4A4

	Manufacturer's Tool No.
WRENCH, bull shaft bearing lock nut.....	MTM-A4-1
WRENCH, front motor support bolt .....	MTM-A4-48
WRENCH, fuel pump drive shaft .....	MTM-A4-22
WRENCH, oil and scavenger pump shaft .....	MTM-A4-20
WRENCH, socket, special, clutch housing retainer nut ....	MTM-A4-33
WRENCH, socket, thin wall, crankshaft nut .....	MTM-C-365
WRENCH, spanner, accessory drive shaft bevel gear lock nut .....	MTM-A4-3
WRENCH, spanner, drive front bearing lock nut .....	MTM-A4-2
WRENCH, spanner, fuel pump drive bearing lock nut ....	MTM-A4-26
WRENCH, spanner, water pump hub holding .....	MTM-A4-7

**Section XIII**

**PREPARATION FOR EXTREME CONDITIONS**

	<b>Paragraph</b>
Extreme heat .....	34
Extreme cold .....	35
Extreme sand or dust .....	36
Underbrush .....	37
Submersion .....	38

**34. EXTREME HEAT.**

a. No special preparations are necessary before operating the power unit under conditions of extreme heat. During operation under these conditions, however, it is important that the cooling system be kept filled with water and checked frequently for proper functioning, as outlined in TM 9-754 (par. 83).

**35. EXTREME COLD.**

a. Preparations for extreme cold include use of correct fuel and oil for low temperature, protection of the cooling system against freezing, checking and adjusting the power unit electrical equipment, and observing the proper starting and operating procedures, as outlined in TM 9-754 (par. 40).

**36. EXTREME SAND OR DUST.**

a. Operation over extremely sandy or dusty terrain will necessitate frequent cleaning of the carburetor air cleaners. The carburetor air cleaners should be cleaned at every opportunity, in some cases as often as several times a day. The procedure for cleaning and servicing of these units is outlined in TM 9-754 (par. 75).

**37. UNDERBRUSH.**

a. When the vehicle is operated through heavy underbrush, or is camouflaged with leaves, branches or other materials, be sure to keep the power unit air inlet grille, at the front of the power unit compartment, and the opening at rear of compartment, free from obstructions. It is also very important that the fuel tank compartment air inlet grilles located, one on each sponson (at rear end) be kept free from obstructions. The radiator air passages should be cleaned out with compressed air whenever possible. Keeping all of the above free from obstructions will insure free passage of air around the fuel tanks and power unit, thus assisting in the displacement of heat.

**ORDNANCE MAINTENANCE — POWER UNIT FOR  
MEDIUM TANKS M3A4 AND M4A4**

**38. SUBMERSION.**

a. If a power unit has been submerged in either salt or fresh water, the following procedures must be observed:

**CAUTION:** Do not attempt to operate power unit after submersion until after it has been completely disassembled, cleaned and inspected. Disassemble power unit immediately for inspection and repairs.

(1) Clean, inspect and oil each part. If the submersion occurred in salt water, wash all parts (other than electrical equipment) in hot, fresh water. Dry after washing and flush with OIL, lubricating, that has been heated to 180 F.

**CAUTION:** Make a careful inspection of each part salvaged to ascertain not only the extent of the damage caused by corrosion, but also any other defects caused by the sudden cooling action of the water in cases where the power unit was at operating temperature at the time of submersion. In cases where the power unit has been submerged in salt water for any length of time, parts made of aluminum will invariably be damaged beyond further use.

(2) Flush all electrical equipment, such as starters, generators and distributors, thoroughly with fresh water, dry and recondition before using. This reconditioning operation must include an inspection for detrimental corrosion and the condition of all insulation and thorough testing of all electrical circuits. All windings that are otherwise serviceable, should be baked in an oven at 140 F for 4 hours before reassembly. Replace all high-tension ignition wiring.

Section XIV

**PACKING, SHIPPING, AND STORAGE**

	Paragraph
Pack for shipment or storage.....	39
Unpack power unit from shipping box.....	40
Prepare power unit for service.....	41

**39. PACK FOR SHIPMENT OR STORAGE.**

a. To pack a power unit assembly for shipment or yard storage, a shipping box (fig. 200) should be used, to eliminate any damage to the power unit. These two types of boxes are used in shipment of the power unit from manufacturer: the stationary cover type box being used for shipment of power unit, less radiator, fan and clutch; the removable cover type box being used for shipment of power unit, with or without radiator, fan and clutch. Whenever possible, these boxes should be saved for re-shipment of the power unit. The shipping weight of the power unit, when properly boxed for shipment, is approximately 4,700 pounds (less radiator, fan and clutch), 6,300 pounds (including radiator, fan and clutch).

**b. Prepare Power Unit For Storage Or Shipment.**

- |                      |   |
|----------------------|---|
| AIR, compressed      | WRENCH, open-end, 1-in.                 |
| GUNS, spray (2)      | WRENCH, open-end, $\frac{1}{8}$ -in.    |
| HAMMER, steel        | BATTERY, 12-volt (2)                    |
| HOIST                | TANK, power unit water supply           |
| PLIERS, side-cutting | TANK, power unit oil supply             |
| SLING, power unit,   | TANK, power unit fuel supply            |
| MTM-A4-18            | WRENCH, drain plug, $\frac{7}{16}$ -in. |
| STAND, power unit    | square                                  |

**(1) RUSTPROOF INTERIOR OF POWER UNIT.**

- |                             |                                      |
|-----------------------------|--------------------------------------|
| BATTERY, 12-volt (2)        | TANK, power unit oil supply,         |
| GUN, spray (2)              | 10-gal                               |
| HOIST                       | TANK, power unit fuel supply         |
| STAND, power unit           | WRENCH, open-end, $\frac{1}{8}$ -in. |
| SLING, power unit,          | WRENCH, socket, 1 $\frac{1}{8}$ -in. |
| MTM-A4-18                   |                                      |
| TANK, power unit water sup- |                                      |
| ply, 32-gal                 |                                      |



**ORDNANCE MAINTENANCE — POWER UNIT FOR  
MEDIUM TANKS M3A4 AND M4A4**

- (a) With hoist, mount power unit on stand.
- (b) Connect oil supply tank to both oil pressure and oil scavenger pump tubes, on right side of power unit.
- (c) Connect water outlet and inlet tubes on power unit to a suitable water supply which will hold water temperature below 160 degrees F (only on power units not equipped with radiator).
- (d) Using two 12-volt batteries, connect in series. Connect wire to starter motor and also to wire to No. 2 coil.
- (e) Connect fuel supply tank to power unit.
- (f) Drain lubricating oil from power unit and use a mixture of one part corrosion-preventive concentrate AV-VV-C-576 and three parts OIL, engine, SAE 10 (USA 2-104a) during the following operation. This treatment will coat all interior surfaces of power unit except upper cylinder walls and valve heads.
- (g) While operating the power unit for rustproofing the interior of the power unit, use only unleaded gasoline.
- (h) Disconnect carburetor air cleaner to carburetor air tubes, at carburetor end. Start the power unit and gradually bring speed up to 1,200 revolutions per minute. Run idle at this speed for 15 minutes. During the last 3 minutes of operation, use 2 spray guns and spray a mixture of 1 part corrosion-preventive concentrate AV-VV-C-576 and 3 parts OIL, engine, SAE 10 (USA 2-104a) into air horns which direct air to the carburetors. Open the throttle for a short burst of speed, turn off ignition and, with throttle open, continue spraying oil into air horns until power unit stops. This treatment will give adequate protection to the upper cylinder walls and valve heads.
- (i) During the spraying operation, shut off fuel supply so that the carburetors run dry when the power stops. Approximately 1½ minutes are required to run the carburetors dry at 1,200 revolutions per minute.
- (j) Using 1½-inch socket wrench, remove drain plug from power unit oil pan and drain oil from unit. After draining, install drain plug and tighten securely.
- (k) Attach tag to fuel pump which reads: "CAUTION: Use only unleaded fuel until power unit is installed and ready for final service." Attach second tag to power unit which reads: "CAUTION: This power unit has been treated for storage in accordance with specification AXS 836 on (date) ..... Use OIL, engine SAE 10 (USA 2-104a) when power unit is put in service."
- (l) Disconnect lines from oil, water and fuel supply tanks. Using hoist and sling, remove power unit from stand.

**PACKING, SHIPPING, AND STORAGE**

(2) **DRAIN ALL RADIATOR COOLANT FROM WATER LINES AND CYLINDER BLOCKS.**

**AIR**, compressed

**PLIERS**, side-cutting

**WRENCH**, drain plug,  $\frac{7}{16}$ -in.

square

Remove drain plug from radiator lower tank. Remove locking wires from cylinder block drain cocks, located at distributor end of cylinder blocks (fig. 2), open drain cocks (turn counterclockwise) and allow to drain. Apply compressed air to drain cocks, and radiator inlet adapters alternately, to remove surplus coolant.

(3) **REMOVE CARBURETOR TO AIR CLEANER TUBE ASSEMBLY** (only if radiator is to be removed).

**PLIERS**, side-cutting

Remove safety wire (side-cutting pliers) and loosen thumbscrew which secures hose clamp sufficiently to permit disconnecting the air cleaner tube assembly from the carburetor.

(4) **COVER ALL OPENINGS TO THE INTERIOR OF THE POWER UNIT.**

(a) Use Dearborn Chemical Co.'s No. 4 No-ox-idized Fabric Wrapper to cover all openings. **NOTE:** Make all seams and seals with Dearborn Chemical Co.'s No. 6 sealer compound. These openings include:

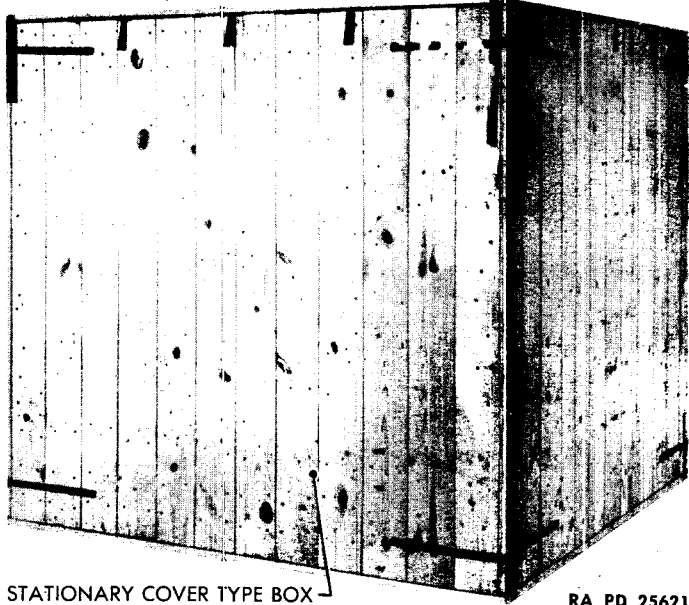
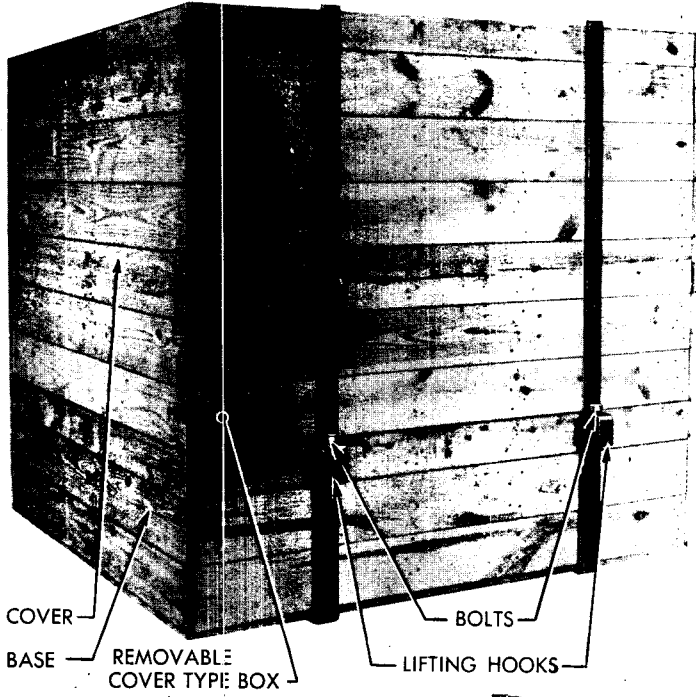
1. Radiator outlet tube, both right and left (if exposed).
2. Radiator inlet tubes, right, left and center (if exposed).
3. Carburetor air inlet, each of the five carburetors (if exposed).
4. Oil supply tank air vent tube.
5. Crankcase ventilator air cleaner.
6. Exhaust pipe, both right and left.
7. Engine to oil tank tube.
8. Engine to oil cooler tube.

**NOTE:** The wrapper shall be sealed to the pipes for at least 1½ inches of lap over the metal with Dearborn Chemical Co.'s sealer compound No. 6 in the lap. The edge of the joint between the wrap and the metal shall be given an additional coat of sealer.

(5) **COVER ALL ELECTRICAL PARTS.** All electrical parts which can be satisfactorily wrapped shall be covered with No. 4 No-ox-idized Fabric Wrapper and sealed by brushing the edge of the wrap with No. 6 sealer. These parts include:

- (a) Ignition distributors (one on each engine).
- (b) Ignition coils (one on each engine).

ORDNANCE MAINTENANCE — POWER UNIT FOR  
MEDIUM TANKS M3A4 AND M4A4



RA PD 25621

Figure 200 — Shipping Box, Removable Cover Type

**PACKING, SHIPPING, AND STORAGE**

(c) Exhaust stack temperature warning indicator sending units (one on each engine).

(d) Starter motor.

(e) Electrical connecting plugs.

**NOTE:** All sharp edges and corners which will bear against the outer covering of the power unit shall be adequately covered with additional Dearborn Chemical Co.'s No. 4 No-ox-idized Fabric Wrapper to prevent rupture of the bag.

**(6) COVER ENGINE DRIVEN GEAR SHAFT.**

(a) Cover the driven gear shaft with Dearborn Chemical Co.'s No-ox-ID "A" (rust-preventive compound—extreme service) and wrap with Dearborn Chemical Co.'s No. 4 No-ox-idized Fabric Wrapper.

**(7) TREATMENT OF CARBURETORS AND EXPOSED THREADS OF BOLTS AND NUTS.**

(a) Coat all cast iron parts of carburetors and exposed threads of bolts and nuts with rust compound—medium, such as Dearborn Chemical Co.'s No-ox-ID "A."

**(8) PREPARE BAG FOR LOWER HALF OF POWER UNIT.**

(a) For engine without radiator, construct a bag out of No. 4 No-ox-idized Fabric Wrapper. Provide slots in the sides of the bag to permit fitting around the power unit front supports. Precut holes at the bottom of the slots to the size of the supports and attach tabs, 3½ inches long, at each side and each corner of the hole.

(b) Seal strips (2-in. wide) of No. 4 No-ox-idized Fabric Wrapper to the power unit supports, where support bolts to gear housing.

(c) With power unit suspended from hoist, place bag in position on power unit and seal the tabs on the sides of the holes to the 2-inch strips and mold to power unit supports. Wrap a strip of No. 4 No-ox-idized Fabric Wrapper outside the tabs. Seal the bag around the supports. Seal the slots in the bag with either a rolled or lock type seam.

**CAUTION:** Care must be exercised in installing the bag around the power unit, to prevent puncture. If the bag is cut or punctured, seal the hole with a patch of No. 4 No-ox-idized Fabric Wrapper so that the laps around the hole are at least 6 inches wide. Give the edges of the lap an additional exterior coat of No. 6 sealer.

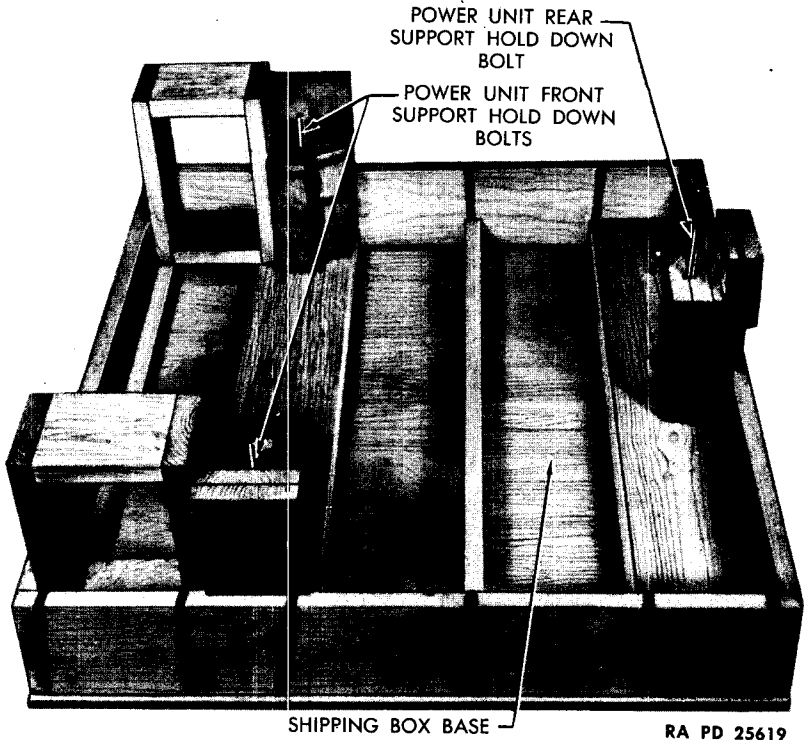
**(9) SECURE POWER UNIT IN BOX (figs. 201 and 202).**

**HOIST**

**WRENCH**, open-end, 1 in.

Lower power unit into box and secure with 3 nuts, one at each front power unit support and one at rear power unit support. Tighten nuts

**ORDNANCE MAINTENANCE — POWER UNIT FOR  
MEDIUM TANKS M3A4 AND M4A4**



**Figure 201 — Base Of Shipping Box**

securely. Distribute 12 one-pound bags of silica gel around the power unit and tie where convenient (on power units not equipped with radiator). On power units equipped with radiator, use 16 one-pound bags of silica gel.

(10) **INSTALL TOP HALF OF BAG** (fig. 203).

Immediately after distributing silica gel, place top half of bag over power unit and seal to the lower half of bag with rolled seams. **NOTE:** Have the seams lap at least 4 inches, before sealing and rolling.

(11) **PACK CARBURETOR TO AIR CLEANER TUBE IN BOX** (fig. 203) (if tubes are removed from unit).

**PLIERS**, side-cutting

Remove locking wires and loosen thumbscrews on hose clamps in center of tube. Separate tube at center. Cover all openings of tube with No. 4 No-ox-idized Fabric Wrapper and seal with No. 6 sealer. **NOTE:** *Make the seal between the wrapper and tube on the metal part of the tube, and not on the rubber hose.* Place the sections of the tube in the shipping box,

PACKING, SHIPPING, AND STORAGE

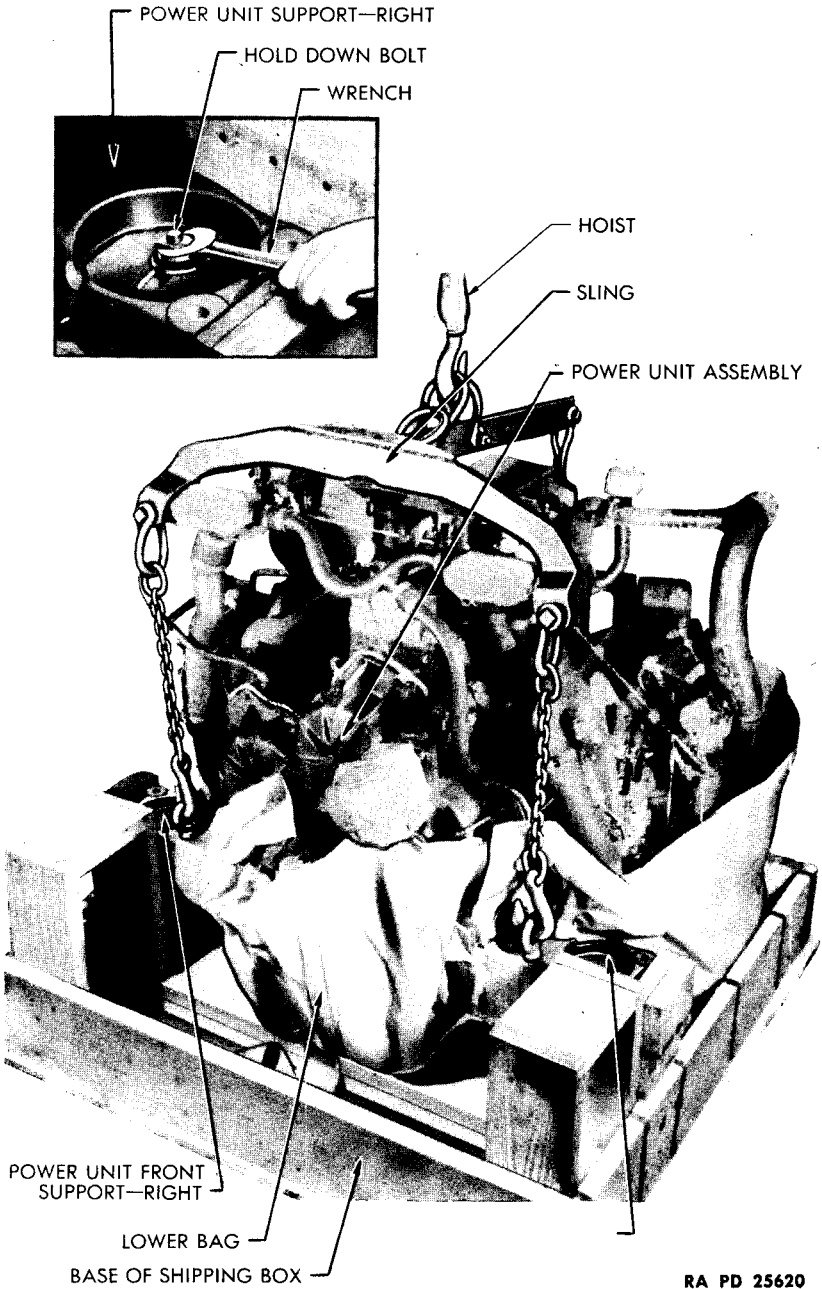
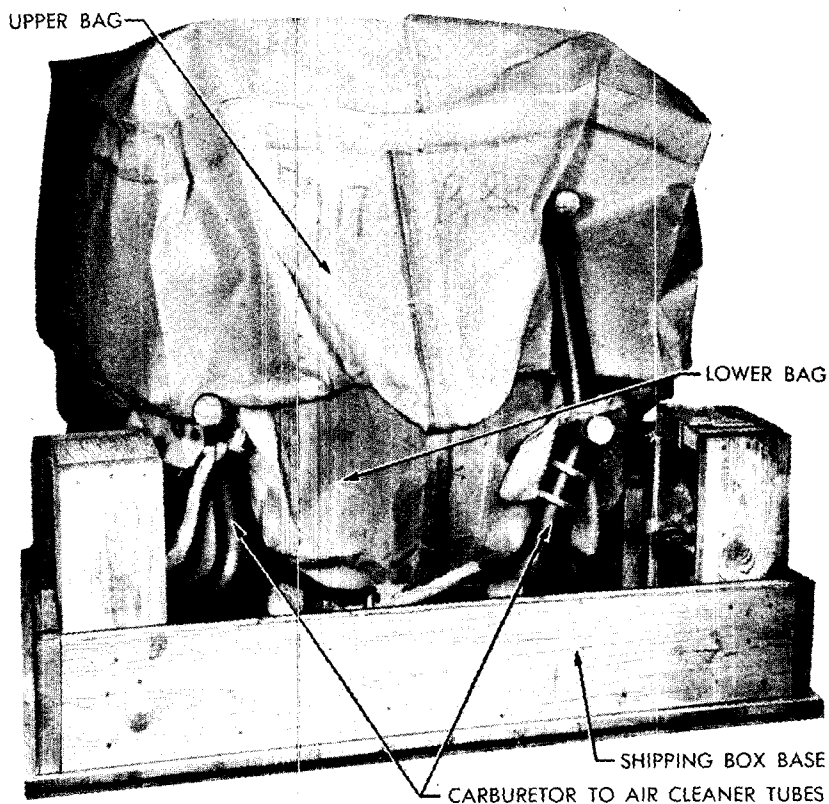


Figure 202 — Lowering Power Unit Into Shipping Box Base

ORDNANCE MAINTENANCE — POWER UNIT FOR  
MEDIUM TANKS M3A4 AND M4A4



RA PD 25622

**Figure 203 — Power Unit In Shipping Box Base, Ready To Install Cover**

outside the power unit, along the bottom and one side, being careful not to damage the bag.

**(12) INSTALL COVER ON BOX.**

**HAMMER**, steel  
**HOIST**

**WRENCH**, open-end, 1-in.

Using hoist, lower cover on box and secure with four bolts in lifting hooks (on shipping box with removable cover). On box with stationary cover, place boards in position and secure with nails.

**40. UNPACK POWER UNIT FROM SHIPPING BOX.**

**a. Equipment.**

**HOIST**  
**SLING**

**STAND**, power unit  
**WRENCH**, open-end, 1-in.

**PACKING, SHIPPING, AND STORAGE**

**b. Procedure.**

**(1) REMOVE COVER.**

HOIST  
PULLER, nail

WRENCH, open-end, 1-in.

When removing cover from box with stationary cover shown in figure 200, remove nails (to preserve box for further use) and remove boards individually. When removing cover from box with removable cover shown in figure 200, use 1-in. open-end wrench to remove the four bolts at lifting hooks, attach hoist and lift cover off.

**(2) REMOVE POWER UNIT FROM SHIPPING BOX (figs. 201 and 202).**

HOIST  
SLING

STAND, power unit  
WRENCH, open-end, 1-in.

Remove nuts from hold-down bolts, at right and left front and rear supports (1-in. open-end wrench). Attach lifting sling to lifting eyes, at each power unit support, lift unit with hoist and place on stand.

**41. PREPARE POWER UNIT FOR SERVICE.**

**a. Equipment.**

BATTERY, 12-volt (2)  
PLIERS, side-cutting  
TANK, power unit fuel supply

TANK, power unit oil supply  
WRENCH, socket,  $\frac{9}{16}$ -in.

**CAUTION:** When removing a power unit from shipping box, it is very important that extreme care be exercised in its removal, to prevent damage to the power unit. It is also necessary to remove all sealing compound and wrapper to eliminate any danger of this foreign matter being drawn into the interior of the power unit. **NOTE:** Power units shipped from manufacturer, for service, have been tested on dynamometer, before shipment, therefore they do not require such tests before installation in vehicle.

**b. Procedure.**

**(1) REMOVE WRAPPERS FROM THE FOLLOWING:**

- (a) Radiator outlet tubes, both right and left (if openings are wrapped).
- (b) Radiator inlet tubes, both right, left and center (if openings are wrapped).
- (c) Carburetor air inlet, each of the five carburetors (if openings are wrapped).
- (d) Oil supply tank air vent tube.
- (e) Crankcase ventilator air cleaner.
- (f) Exhaust pipe, both right and left.



**ORDNANCE MAINTENANCE — POWER UNIT FOR  
MEDIUM TANKS M3A4 AND M4A4**

- (g) Engine to oil tank tube.
- (h) Engine to oil cooler tube.
- (i) Carburetor to air cleaner tube.
- (j) Ignition distributors (one on each engine).
- (k) Ignition coils (one on each engine).
- (l) Exhaust stack temperature warning indicator sending unit (one on each engine).
- (m) Water temperature gage sending units.
- (n) High water temperature warning signal sending unit.
- (o) Oil pressure gage sending unit.
- (p) Low oil pressure warning signal sending unit.
- (2) **INSTALL RADIATOR ASSEMBLY** (if unit is shipped less radiator).
- (a) Follow procedure outlined in TM 9-754 (par. 90 e).
- (3) **INSTALL CLUTCH AND FAN ASSEMBLY** (if unit is shipped less clutch and fan).
- (a) Follow procedure outlined in TM 9-754 (par. 94).
- (4) **INSTALL CARBURETOR TO AIR CLEANER TUBE ASSEMBLY** (fig. 5) (if tubes have been removed).

**PLIERS**, side-cutting

**WRENCH**, socket,  $\frac{9}{16}$ -in.

Place tube assemblies in position, as shown in figure 5. Insert tube in rubber hose on carburetors at the points shown. Position hose clamps on hose and tighten thumbscrews to secure. Lock thumbscrews in position with locking wires through holes in thumbscrews (side-cutting pliers). Place both right and left tubes in position on radiator and secure each bracket to radiator with 2 cap screws, flat washers and lock washers ( $\frac{9}{16}$ -in. socket wrench).

**(5) INSPECT FOR OPERATION.**

**BATTERY**, 12-volt (2)

**TANK**, power unit oil supply

**TANK**, power unit fuel supply

(10 gal.)

With power unit mounted on suitable stand to permit operation, perform the following operations:

- (a) Fill cooling system (capacity 32 gal.).
- (b) Connect oil supply tank to both oil pressure and oil scavenger pump tubes, on right side of power unit, and fill with ten gallons of oil.
- (c) Using two 12-volt batteries, connected in series, connect wire to starter motor and also to low tension wire to No. 2 coil.
- (d) Operate power unit and inspect for oil and water leaks.

CHAPTER 3

Section I

**POWER UNIT IGNITION SYSTEM**

	Paragraph
Description .....	42
Tabulated data and specifications .....	43
Second echelon operations .....	44
Echelon breakdown of maintenance .....	45

**42. DESCRIPTION.**

a. **General.** The power unit ignition system (fig. 204) consists of an actuating circuit, main circuit and the individual engine ignition systems.

(1) The actuating circuit consists of the instrument box ignition switch which controls the operation of the solenoid switch in the main circuit.

(2) The main circuit consists of a master battery switch, battery box shunt, terminal block, ignition solenoid switch and ignition filter.

(3) The individual engine ignition system consists of a coil, coil resistor, distributor and spark plugs.

(4) Current is fed from the ignition filter to the ignition coil on No. 2 engine and from No. 2 to the left to No. 3 engine, and to the right to Nos. 1, 5 and 4 engines in order named. From No. 4 engine ignition coil a wire connects to the solenoid operated fuel shut-off valve.

**b. Operation.**

(1) When the instrument box ignition switch is turned "ON" the actuating circuit is closed. Closing of this circuit actuates a plunger in the ignition solenoid and closes the main circuit, from battery to ignition coils. The use of the actuating circuit obviates the necessity of carrying the ignition current to the instrument box switch.

(2) When the main circuit is closed by the manual operation of master battery switch, and the action of the actuating circuit in closing the ignition solenoid switch, current flows from the batteries through the battery box shunt, solenoid switch and ignition filter to the individual engine ignition systems.

(3) The individual engine ignition system consists of a resistor (fig. 205) mounted on the coil, which limits the current in the ignition pri-



**POWER UNIT IGNITION SYSTEM**

mary coil, the distributor (fig. 207) with breaker contacts, shunted by a condenser, which interrupts the current in the primary (low-tension) winding of the ignition coil, and a rotor in the distributor which distributes the resulting high-tension current from the secondary (high-tension) winding of the coil to the appropriate spark plug.

**43 TABULATED DATA AND SPECIFICATIONS.**

**a. Ignition System.**

Ignition voltage .....	24-volt
Spark plugs	
Make .....	Autolite
Type .....	A 5
Distributor	
Make .....	Autolite
Rotation.....	Counterclockwise (viewed from distributor end)
Control .....	Full automatic
Drive .....	Gear, from camshaft
Base adjustment .....	20 degrees
Cam angle .....	40 degrees

**44. SECOND ECHELON OPERATIONS.**

a. In view of the fact that many second echelon operations described in TM 9-754 are often performed by ordnance maintenance personnel, the information is not repeated in this manual, therefore, ordnance maintenance personnel should refer to TM 9-754 for this information. It will be noted that reference is made to the technical manual previously mentioned, where this applies.

**45. ECHELON BREAKDOWN OF MAINTENANCE.**

a. Refer to paragraph 4.

ORDNANCE MAINTENANCE — POWER UNIT FOR  
MEDIUM TANKS M3A4 AND M4A4

Section II

**TROUBLE SHOOTING**

	Paragraph
General .....	46
Symptoms .....	47
Diagnosis and tests .....	48

**46. GENERAL.**

a. The following outline in paragraph 47 lists the probable cause and probable remedy for power unit failures due to the ignition system. Paragraph 48 is given to assist in locating the actual point of trouble.

**47. SYMPTOMS.**

**a. Engine Fails To Fire When Cranked By Starter.**

Probable Cause	Probable Remedy
Actuating circuit open circuited or defective solenoid ignition switch	Check (par. 48 b (3) ) and replace defective wire or unit. Check all connections for corrosion and tightness.
Main circuit open circuited	Check (par. 48 b (4) ) and replace faulty wire or unit. Check all connections for corrosion and tightness.
Solenoid fuel valve inoperative	Check (par. 48 b (2) ) and repair or replace.
Failure of fuel supply	Refer to TM 9-754 (par. 70).

**b. Power Unit Fails To Fire On One Engine.**

Lack of fuel	Refer to TM 9-754 (par. 70).
Spark plugs inoperative	Clean, adjust gap (par. 48 c (1) ).
Incorrect ignition timing	Reset (par. 63).
Secondary circuit failure	Check (par. 48 c (2) and (3) ) and replace faulty parts. Wipe cap inside and out, also spark plug porcelain and wires, with clean, dry rag.
Failure of primary circuit	Check (par. 48 c (4) and (5) ) and replace faulty wires or units.

**TROUBLE SHOOTING**

**c. Power Unit Backfires, Runs Unevenly Or Loses Power.**

<i>Probable Cause</i>	<i>Probable Remedy</i>
Spark plug wires crossed	Check (par. 48 d (1) ) and correct.
Loose or dirty connections at coil, resistor or distributor	Clean and tighten (par. 48 d (2) ).
Broken resistor element	Check and replace.
Incorrect ignition timing	Reset (par. 63).
Faulty distributor	Check for burned tracks (par. 48 d (2) (d) ).
Faulty carburetion	Refer to TM 9-754 (par. 70).

**d. Power Unit Continues To Run When Ignition Switch Is Turned Off.**

Preignition	Use of correct spark plugs (par. 48 e (1) ).
Faulty solenoid switch, instrument box switch or crossed circuit in main ignition circuit	Check and replace faulty units (par. 48 e (2) ).

**48. DIAGNOSIS AND TESTS.**

**a. Equipment.**

GAGE, round, 0.024 to 0.027	WRENCH, open-end, $\frac{3}{8}$ -in.
LAMP, test	WRENCH, open-end, $\frac{7}{16}$ -in.
PLIERS	WRENCH, open-end, $\frac{1}{2}$ -in.
PLIERS, side-cutting	WRENCH, open-end, $\frac{9}{16}$ -in.
SCREWDRIVER	WRENCH, socket, $\frac{3}{8}$ -in.
TESTER, Federal Stock, No. 17-T-5520	WRENCH, thin wall, deep socket, $\frac{13}{16}$ -in.

NOTE: Before starting the procedure as outlined below the ignition circuit diagram (fig. 204) should be thoroughly studied to assist in understanding each circuit and why each step is taken.

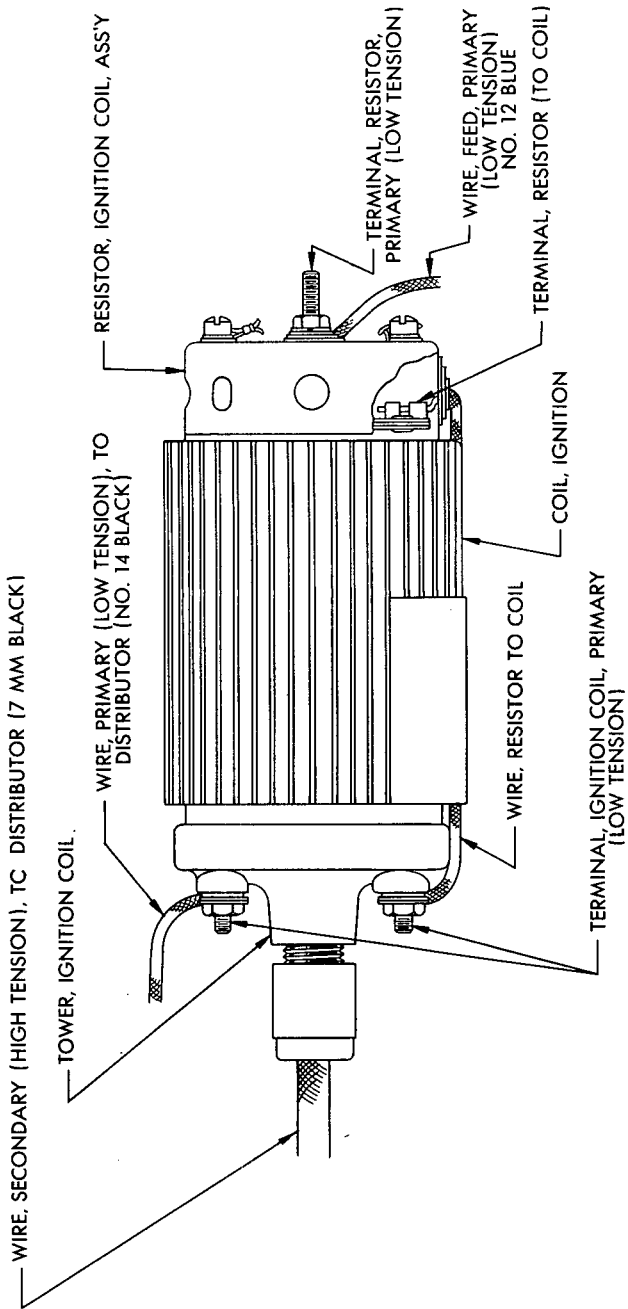
**b. Power Unit Fails To Fire When Cranked.**

(1) CHECK FOR CURRENT AT IGNITION COIL RESISTOR ON No. 4 ENGINE.

(a) Turn on ignition switch.

(b) Touch one lead of test lamp to ground and other lamp lead to primary (low-tension) terminal of coil resistor (fig. 205) for No. 4 engine.

ORDNANCE MAINTENANCE — POWER UNIT FOR  
MEDIUM TANKS M3A4 AND M4A4



RA PD 25274

Figure 205 — Coil And Resistor

## TROUBLE SHOOTING

(c) If test lamp burns, current is reaching this point, and the trouble is in the solenoid fuel valve or fuel system. If test lamp does not burn, the trouble is in the actuating circuit (test 3) or main circuit (test 4).

(2) CHECK SOLENOID FUEL VALVE (fig. 204).

(a) Turn ignition switch off and on. If internal action is felt, the valve is operating.

(b) If internal action is not felt remove No. 12 blue wire from valve ( $\frac{3}{8}$ -in. open-end wrench) and connect test lamp leads between this wire (No. 12 blue) and ground. Turn on ignition switch; if test lamp burns, current is reaching valve, therefore, valve is inoperative.

(c) If test lamp does not burn, check lead from primary (low-tension) terminal (fig. 205) of coil resistor on No. 4 engine for open circuit. Touch one lead of test lamp to primary (low-tension) terminal (fig. 205) of coil resistor on No. 4 engine, and other test lamp lead to ground. If test lamp burns, there is an open circuit in the No. 12 blue wire from this terminal to the solenoid fuel valve.

(3) CHECK ACTUATING CIRCUIT.

(a) Check ignition solenoid switch (par. 50) by ear. Turn ignition switch on and off. If click is heard, actuating circuit is operating.

(b) Check ignition solenoid switch with test lamp, (where outside noise interferes) by touching one lead of test lamp to ground, and other lead to small terminal on ignition solenoid switch to which the No. 16 blue wire is attached (fig. 204). Turn on ignition switch.

1. If test lamp burns, solenoid switch is defective. Replace solenoid switch.

2. If test lamp does not burn, there is an open circuit in the actuating circuit.

(c) *Check Actuating Circuit For Open Circuit.* Ground one lead of test lamp and touch other test lamp lead to the following points in order:

1. Terminal D (fig. 204) in the 6-contact connector, to which No. 16 blue wire is attached. If lamp burns, open circuit is between this terminal and solenoid switch. If lamp does not burn, proceed to next point.

2. Terminal on ignition switch to which No. 16 blue wire is attached. If lamp burns, open circuit is between this terminal and terminal D in 6-contact connector. If lamp does not burn, proceed to next point.

3. Terminal on ignition switch to which No. 12 black wire is attached. If lamp burns, open circuit is in ignition switch. If lamp does not burn, open circuit is between this point and terminal on bus bar (fig. 204) carrying 3 No. 12 black wires.



**ORDNANCE MAINTENANCE — POWER UNIT FOR  
MEDIUM TANKS M3A4 AND M4A4**

**(4) CHECK MAIN CIRCUIT FOR OPEN CIRCUIT.**

(a) Remove cover from ignition filter unit mounted in power unit compartment (screwdriver).

(b) Close master switch and turn on ignition switch.

(c) Touch one lead of test lamp to ground and other lead to the following terminals in order:

1. Primary (low-tension) terminal (fig. 205) of coil resistor on No. 2 engine. If lamp burns, there is no open circuit in main circuit. If lamp does not burn, proceed to next point.

2. Terminal on ignition filter unit carrying low-tension feed wire to coils (fig. 204). If lamp burns, open circuit is between this terminal and primary (low-tension) terminal on coil resistor of No. 2 engine. If lamp does not burn, proceed to next point.

3. Terminal on filter unit which goes to solenoid switch. If lamp burns, open circuit is in filter. If lamp does not burn, proceed to next point.

4. Large terminal on ignition solenoid switch which is connected to filter (No. 12 blue wire, fig. 204). If lamp burns, open circuit is between solenoid switch and filter (No. 12 blue wire) (fig. 204). If lamp does not burn, proceed to next point.

5. Large terminal on ignition solenoid switch which is connected to battery box shunt (fig. 204). If lamp burns, open circuit is in solenoid switch. If lamp does not burn, open circuit is between this point and battery box shunt.

**c. Power Unit Fails To Fire On One Engine.**

**(1) CHECK FOR SECONDARY (HIGH-TENSION) SPARK AT SPARK PLUGS.**

(a) Start power and set at idle. **NOTE:** Do not let power unit idle at 750 revolutions per minute for longer than 5 minutes. If longer time is necessary, adjust hand throttle to increase speed to 950-1,000 revolutions per minute.

(b) Check for spark at spark plugs by placing screwdriver with insulated handle against spark plug terminal and extend end of screwdriver to within  $\frac{1}{8}$  inch of cylinder head. If spark jumps steadily to cylinder head, stop power unit and check the following points:

1. Remove spark plugs ( $\frac{1}{8}$ -in. thin wall, deep socket wrench) in this engine and examine for fouling or wide spark plug gap. Check gap with round gage. Gap must be 0.024 to 0.027-inch.

2. Check ignition timing. Refer to paragraph 63.

## TROUBLE SHOOTING

3. If spark plugs are clean, spark plug points properly spaced and timing correct, the trouble is in the fuel system. Refer to TM 9-754 (par. 70).

(2) CHECK FOR SECONDARY (HIGH-TENSION) SPARK AT DISTRIBUTOR IF NO SPARK JUMPED AT SPARK PLUGS WHEN SCREWDRIVER WAS USED.

(a) Remove secondary (high-tension, 7-mm black) wire from center of distributor cap by unscrewing knurled nut with fingers, or with pliers, if necessary (fig. 204).

(b) Check other end of 7-mm black wire to be sure it is securely fastened in ignition coil tower (fig. 205) and that ignition suppressor is securely fastened in wire (fig. 204).

(c) Hold the free end of wire about  $\frac{1}{4}$ -inch from ground or power unit. Start power unit and let it idle.

(d) If spark jumps, stop power unit and check the following points:

1. Check all spark plug wires for tightness in distributor cap.
2. Check for burned tracks between these terminals and metal distributor housing.
3. Examine wires for cracks or punctured insulation. Check wires with ignition circuit (high-tension) tester (Federal Stock No. 17-T-5520).
4. Remove distributor cap (side-cutting pliers and screwdriver). Examine inside of cap for burned tracks or cracks, which will cause secondary (high-tension) spark leak to ground.
5. Remove distributor seal plate (side-cutting pliers and screwdriver). Restart power unit and allow to idle. Hold secondary (high-tension) 7-mm black wire terminal about  $\frac{1}{8}$  inch from center of rotor. NOTE: Hold wire so it does not interfere with rotor. If spark jumps to conductor strip on rotor, but fails to jump over rotor to distributor shaft or condenser case, the rotor insulation is punctured between the conductor strip and end of distributor shaft. Replace rotor.

(3) CHECK DISTRIBUTOR AND COIL IF SPARK DOES NOT JUMP FROM SECONDARY (HIGH-TENSION, COIL TO DISTRIBUTOR) WIRE TO GROUND.

(a) Remove distributor cap (side-cutting pliers and screwdriver). Remove seal plate (side-cutting pliers and screwdriver).

(b) Check for arcing at distributor breaker contacts. A normal arc is concentrated and blue in color.

1. Have power unit rotated by means of the power unit fan until distributor breaker contacts are positively closed (or when bumper block on breaker arm is not touching the distributor cam).

**ORDNANCE MAINTENANCE – POWER UNIT FOR  
MEDIUM TANKS M3A4 AND M4A4**

2. Turn on ignition switch and open and close breaker contacts by moving the breaker arm with finger and watch color of arcing at breaker contacts.

3. If arc appears normal and contacts are gray and clean, adjust points to proper clearance (par. 61 e) and reassemble distributor cap and seal plate.

4. If arc is broad and yellow or contacts have a burned appearance or are worn, replace both condenser and breaker contacts (pars. 57 and 59).

5. If no arc occurs, examine spring on breaker arm (fig. 207), making sure that it is not broken or grounded, and then proceed to check for open circuit in primary (low-tension) circuit.

6. After making the adjustments or replacements, if any, that were necessary in the above steps, reassemble distributor cap and seal plate.

7. Repeat check for spark with coil high-tension lead (step (2) above). If spark still fails to jump to ground, the secondary (high-tension) winding of the coil has failed. Check coil with ignition circuit (high-tension) tester, (Federal Stock No. 17-T-5520). Replace coil.

**(4) CHECK FOR OPEN CIRCUIT OR GROUND IN PRIMARY (LOW-TENSION) CIRCUIT IF NO ARC OCCURRED WHEN BREAKER CONTACTS WERE SEPARATED IN ABOVE TEST.**

(a) Check for open circuit between primary (low-tension) terminal of resistor on No. 2 coil (to which No. 12 blue wire is attached) and primary (low-tension) terminal post of this distributor (fig. 207) to which No. 14 black wire is attached. Disconnect wire from primary (low-tension) terminal post on distributor ( $\frac{9}{16}$ -in. open-end wrench). Turn on ignition switch. Touch one lead of test lamp to ground and touch other lead to the following terminals in order:

1. Terminal on wire (No. 14 black) removed from distributor primary (low-tension) terminal post. If lamp burns, trouble is in the distributor. If lamp does not burn, proceed to next point.

2. Terminal on ignition coil (to which No. 14 black wire is attached, figure 205), which connects to distributor. If lamp burns, open circuit is in No. 14 black wire from distributor primary (low-tension) terminal post to coil. If lamp does not burn, proceed to next point.

3. Primary (low-tension) terminal of ignition coil which connects to resistor (fig. 205). If lamp burns, open circuit is in coil. If lamp does not burn, proceed to next point.

4. Terminal on resistor which connects to ignition coil (fig. 205) (on late model power units it will be necessary to remove the 2 mounting

**TROUBLE SHOOTING**

screws (screwdriver) which hold this unit to rear of coil in order to reach this terminal). If lamp burns, open circuit is in the black wire which leads from the coil to resistor. If lamp does not burn, proceed to the next point.

5. Primary (low-tension) stud on feed side of resistor to which No. 12 blue wire is attached (fig. 205). If lamp burns, open circuit is in resistor. If lamp does not burn, proceed to next point.

6. Terminal on resistor of No. 2 coil to which No. 12 blue wire is attached. If lamp burns, open circuit is between resistor on No. 2 coil and resistor on engine being checked. If lamp does not light, check for ground as outlined in next step. **NOTE:** It will be noted in making these tests that the lamp will not burn with the same intensity from one point to the next. This is normal and is due to the resistance of the coil primary winding and the resistor.

**(5) CHECK FOR GROUND BETWEEN COIL RESISTOR AND DISTRIBUTOR OF THE ENGINE BEING CHECKED.**

(a) Reconnect wire to distributor primary (low-tension) terminal post (fig. 207) ( $\frac{9}{16}$ -in. open-end wrench).

(b) Remove distributor cap and seal plate (screwdriver and side-cutting pliers) and hold breaker contacts open.

(c) Disconnect all wires from primary (low-tension) terminal on resistor ( $\frac{3}{8}$ -in. open-end wrench) and connect a 3-candlepower, 24-volt test lamp between the feed wire (No. 12 blue) and the terminal of resistor. Make sure that lamp and wires are insulated from ground.

(d) Turn on ignition switch. If lamp does not burn, the circuit is free from grounds. If lamp burns, disconnect leads at the following points in order:

1. No. 14 black wire from distributor primary (low-tension) terminal post. If lamp does not continue to burn, ground is in distributor. If lamp continues to burn, proceed to next point.

2. No. 14 black wire at ignition coil (fig. 205). If lamp does not continue to burn, ground is in No. 14 black wire. If lamp continues to burn, proceed to next point.

3. Black wire on ignition coil which connects to resistor (fig. 205). If lamp does not continue to burn, ground is in coil. If lamp continues to burn, proceed to next point.

4. Black wire on resistor which leads to ignition coil (fig. 205). (On late model power units it will be necessary to remove the 2 mounting screws which hold this unit to rear of coil in order to reach this terminal).

**ORDNANCE MAINTENANCE — POWER UNIT FOR  
MEDIUM TANKS M3A4 AND M4A4**

If lamp continues to burn, the element of the resistor unit is grounded—replace this unit.

**d. Power Unit Backfires, Runs Unevenly Or Loses Power.****(1) CHECK POSITION OF SPARK PLUG WIRES IN DISTRIBUTOR CAP TERMINALS.**

Terminals on the distributor cap are stamped with the correct spark plug number to correspond with the numbered tag on the spark plug wire. If the numbers are not legible, proceed as follows:

(a) Remove all wires from distributor cap by unscrewing knurled nuts with fingers (pliers may be used, if necessary).

(b) Turn on ignition switch and connect test lamp between coil resistor terminal to which No. 12 blue wire is attached (fig. 205) ( $\frac{3}{8}$ -in. open-end wrench) and one of the spark plug wires. Touch jumper wire to ground, and with other end touch each of the spark plug terminals. When light burns the wire attached to the test lamp should be placed in the distributor cap terminal numbered to correspond with that plug. Repeat test until all wires are properly placed.

**(2) IF SPARK PLUG WIRES ARE PROPERLY CONNECTED, CHECK THE FOLLOWING POINTS FOR LOOSE CONNECTIONS OR INTERMITTENT GROUNDS:**

(a) Check primary wire connections at coil and distributor. Make sure they are clean, tight and free from ground.

(b) Check coil resistors for broken elements or loose connections.

(c) Check remaining ignition circuit for loose connections or intermittent grounds.

(d) If backfires are confined to one engine, remove distributor cap (screwdriver and side-cutting pliers) and examine for burned tracks between inserts or to ground. Replace defective cap.

**(3) CHECK IGNITION TIMING (par. 63).**

(a) If ignition is too early, it will result in preignition, backfire and loss of power. If ignition is timed too late, it will result in sluggish operation with loss of power.

**(4) IF ABOVE CHECKS FAIL TO CORRECT THE TROUBLE, CHECK SHOULD BE MADE OF CARBURETION (refer to TM 9-754, par 71).**

## TROUBLE SHOOTING

**e. Power Unit Continues To Run When Ignition Switch Is Turned Off.**

(1) IF POWER UNIT CONTINUES TO RUN FOR ONLY A LIMITED TIME, CHECK THE TWO ITEMS BELOW.

(a) Preignition due to incorrect spark plugs.

(b) Engine overheating (refer to TM 9-754) (par. 51 a (5) ).

(2) IF POWER UNIT RUNS CONTINUOUSLY, CHECK FOR SHORTS OR CROSSED CIRCUITS IN ACTUATING OR MAIN CIRCUITS BY FOLLOWING THE PROCEDURE OUTLINED BELOW:

(a) Disconnect wires at the following points in order listed.

1. No. 16 blue wire from instrument box ignition switch ( $\frac{3}{8}$ -in. socket wrench) (fig. 204). If power unit stops, fault is in ignition switch. If power unit continues to operate, proceed to next point.

2. The 6-connector plug in instrument box (fig. 204). If power unit stops, fault is between ignition switch and 6-connector plug. If power unit continues to operate, proceed to next point.

3. Small terminal of ignition solenoid switch to which No. 16 blue wire is attached. If power unit stops, fault is in No. 16 blue wire from this terminal to connector (fig. 204). If power unit continues to operate, proceed to next point.

4. No. 12 blue wire from ignition solenoid switch large terminal which leads to ignition filter ( $\frac{1}{2}$ -in. open-end wrench). If power unit stops, fault is in solenoid switch. If power unit continues to operate, proceed to next point.

5. No. 12 blue wire from ignition filter terminal which leads to solenoid switch (screwdriver). If power unit stops, fault is in No. 12 blue wire from filter to solenoid switch.

ORDNANCE MAINTENANCE - POWER UNIT FOR  
MEDIUM TANKS M3A4 AND M4A4

Section III

**INSTRUMENT BOX IGNITION SWITCH, IGNITION  
SOLENOID SWITCH, IGNITION FILTER, IGNITION COIL,  
HIGH-TENSION WIRING HARNESS, AND SPARK  
PLUGS**

	Paragraph
Instrument box ignition switch.....	49
Ignition solenoid switch.....	50
Ignition filter .....	51
Ignition coil .....	52
High-tension wiring harness .....	53
Spark plugs .....	54

**49. INSTRUMENT BOX IGNITION SWITCH.**

a. **Description.** The instrument box ignition switch is a manually operated switch with 2 positions, "OFF" and "ON," mounted in the right center of the instrument box.

b. **Operation.** Turn lever clockwise, to limit of travel, to turn ignition switch on. When switch is in "ON" position, it is closed and supplies current to operate the solenoid ignition switch.

c. **Removal And Installation.**

(1) Refer to TM 9-754, paragraph 180 c and d for procedure.

**50. IGNITION SOLENOID SWITCH.**

a. **Description.** The ignition solenoid switch is mounted in the battery box control compartment, and completes the ignition circuit automatically, when the instrument panel switch is turned "ON."

b. **Operation.** When the instrument box switch is turned "ON," current in the solenoid forces a disk, attached to a plunger, down against 2 terminals. This completes the ignition circuit. Spring pressure holds the switch open when the instrument box switch is in the "OFF" position.

c. **Removal And Installation.**

(1) Refer to TM 9-754, paragraph 63 b and c for procedure.

**51. IGNITION FILTER.**

a. **Description.** Located in the power unit compartment, this unit filters the electric current as it passes through the unit, thereby reducing radio interference.

**INSTRUMENT BOX IGNITION SWITCH, IGNITION SOLENOID SWITCH,  
IGNITION FILTER, IGNITION COIL, HIGH-TENSION WIRING HARNESS,  
AND SPARK PLUGS**

b. **Inspection And Repair.** All interior terminals in this unit are soldered and no repair is possible. In case of failure, replace with new unit.

c. **Removal And Installation.**

(1) Refer to TM 9-754, paragraph 64 b and c for procedure.

**52. IGNITION COIL.**

a. **Description.** The ignition coils are not similarly located (fig. 3) but the type of mounting is the same. A resistor is mounted on the end of each coil (fig. 205) to limit the current in the primary coil. The breaker contacts in the distributor interrupt the current in the primary (low-tension) winding of the coil which gives the resulting high-tension current in the secondary winding of the coil.

b. **Removal And Installation.**

(1) Refer to TM 9-754, paragraph 65 b and c for procedure.

**53. HIGH-TENSION WIRING HARNESS.**

a. **Description.** The high-tension wiring harness consists of the spark plug wires, distributor cap, conduit and conduit supports (fig. 11). Spark plug wires are marked numerically, near the distributor end, to assist in assembling to cap.

b. **Removal And Installation.**

(1) Refer to TM 9-754, paragraph 68 b and c for procedure.

**54. SPARK PLUGS.**

a. **Description.** The Autolite A5 spark plugs used are 1-piece plugs which can not be disassembled. They have a center electrode and one side wire.

b. **Removal.**

(1) Refer to TM 9-754, paragraph 69, for procedure.

c. **Clean And Adjust Gap.**

(1) Clean thoroughly and reset gap with round gage to 0.024 inch to 0.027 inch. *NOTE: Do not use feeler gage. Make all adjustments on side wire of plug. If center electrode is bent, porcelain may be cracked, resulting in plug failure.*

d. **Installation.**

(1) Refer to TM 9-754, paragraph 69, for procedure.



ORDNANCE MAINTENANCE — POWER UNIT FOR  
MEDIUM TANKS M3A4 AND M4A4

Section IV

**IGNITION DISTRIBUTOR**

	Paragraph
Description .....	55
Removal .....	56
Disassembly .....	57
Inspection and repair .....	58
Assembly .....	59
Governor adjustment .....	60
Distributor breaker contacts, check and adjustment .....	61
Installation .....	62
Ignition timing .....	63

**55. DESCRIPTION.**

a. The distributor for each individual engine is mounted on the engine timing gear case (fig. 1). The distributor is driven by a gear bolted to the camshaft gear (fig. 107). The drive ratio is 1 to 1. The distributor rotates counterclockwise as viewed from the distributor end of the power unit. The purpose of the distributor is to provide current to the primary winding of the ignition coil at the proper time and also to distribute the high-tension voltage to the proper spark plug. The breaker contacts (fig. 207) of the distributor are connected in the coil primary circuit so that the rotation of the cam opens the coil circuit at the proper instant to generate a spark. The distributor cap and rotor (fig. 206) are arranged so that the high-tension voltage is connected to the correct spark plug for firing each cylinder. The distributor is equipped with a centrifugal governor control of the timing (fig. 206). The cam (fig. 206) is connected to the drive shaft through the governor and is so arranged that, as the speed is increased, the relationship of the cam to the breaker arm is changed by the centrifugal action of the governor. The rate and amount of spark advance is controlled by the weight springs and the design of the centrifugal mechanism.

**56. REMOVAL.**

a. Refer to TM 9-754, paragraph 66 c for procedure.

**IGNITION DISTRIBUTOR**

**57. DISASSEMBLY.**

**a. Equipment.**

<b>DRIFT</b>	<b>SCREWDRIVER</b>
<b>HAMMER, 2-lb</b>	<b>WRENCH, open-end, <math>\frac{9}{16}</math>-in.</b>
<b>PLIERS, side-cutting</b>	<b>WRENCH, socket, <math>\frac{1}{4}</math>-in.</b>
<b>PRESS, arbor</b>	

**b. Procedure.**

**(1) REMOVE FOLLOWER GEAR (fig. 206).**

<b>DRIFT</b>	<b>HAMMER, 2-lb</b>
--------------	---------------------

Drive rivet out of shaft (drift and 2-lb hammer) and remove follower gear and thrust washer.

**(2) REMOVE DISTRIBUTOR SEAL PLATE (fig. 208).**

<b>PLIERS, side-cutting</b>	<b>SCREWDRIVER</b>
-----------------------------	--------------------

Remove lock wire (side-cutting pliers). Remove 3 screws securing seal plate (screwdriver) and lift out plate.

**(3) REMOVE DISTRIBUTOR BASE PLATE (fig. 206).**

<b>SCREWDRIVER</b>	<b>WRENCH, open-end, <math>\frac{9}{16}</math>-in.</b>
--------------------	--

Remove lock wire from 2 mounting screws (side-cutting pliers). Remove 2 screws securing base plate (screwdriver). Remove terminal post nut and ( $\frac{9}{16}$ -in. wrench) remove terminal post and washers. Lift out base plate and remove gasket.

**(4) REMOVE BREAKER ARM AND BREAKER CONTACT PLATE (fig. 207).**

<b>PLIERS, side-cutting</b>	<b>WRENCH, socket, <math>\frac{1}{4}</math>-in.</b>
<b>SCREWDRIVER</b>	

Remove lock wires (side-cutting pliers). Remove breaker plate contact lock screw (screwdriver). Remove breaker arm screw ( $\frac{1}{4}$ -in. socket wrench). Lift out breaker arm and breaker contact plate.

**(5) REMOVE CONDENSER (fig. 207).**

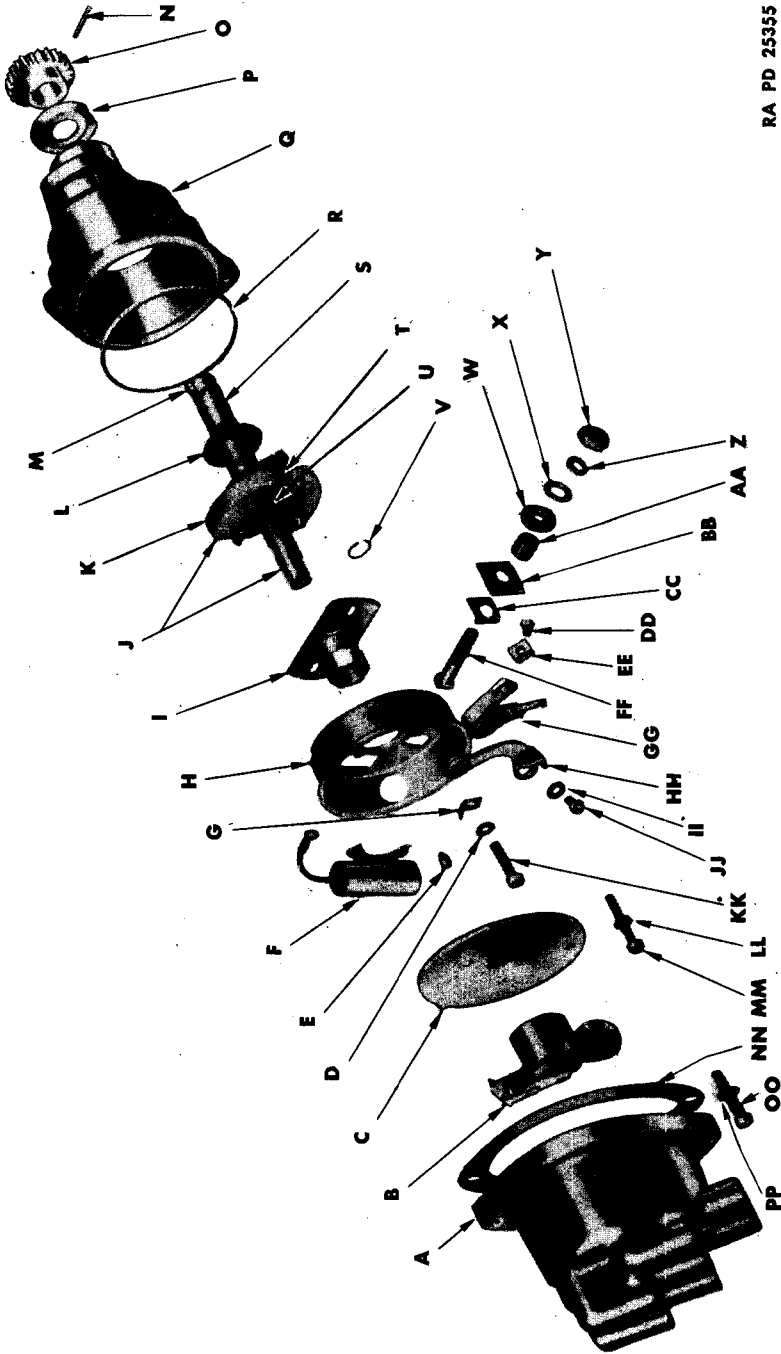
<b>PLIERS, side-cutting</b>	<b>SCREWDRIVER</b>
-----------------------------	--------------------

Remove lock wires (side-cutting pliers) and remove 2 screws (screwdriver). Lift out condenser.

**(6) REMOVE DRIVE SHAFT, CAM AND GOVERNOR ASSEMBLY (fig. 206).**

Lift out drive shaft and governor and remove thrust washer from base. Pull cam off drive shaft.

ORDNANCE MAINTENANCE — POWER UNIT FOR  
MEDIUM TANKS M3A4 AND M4A4



RA PD 25355

Figure 206 — Ignition Distributor, Exploded

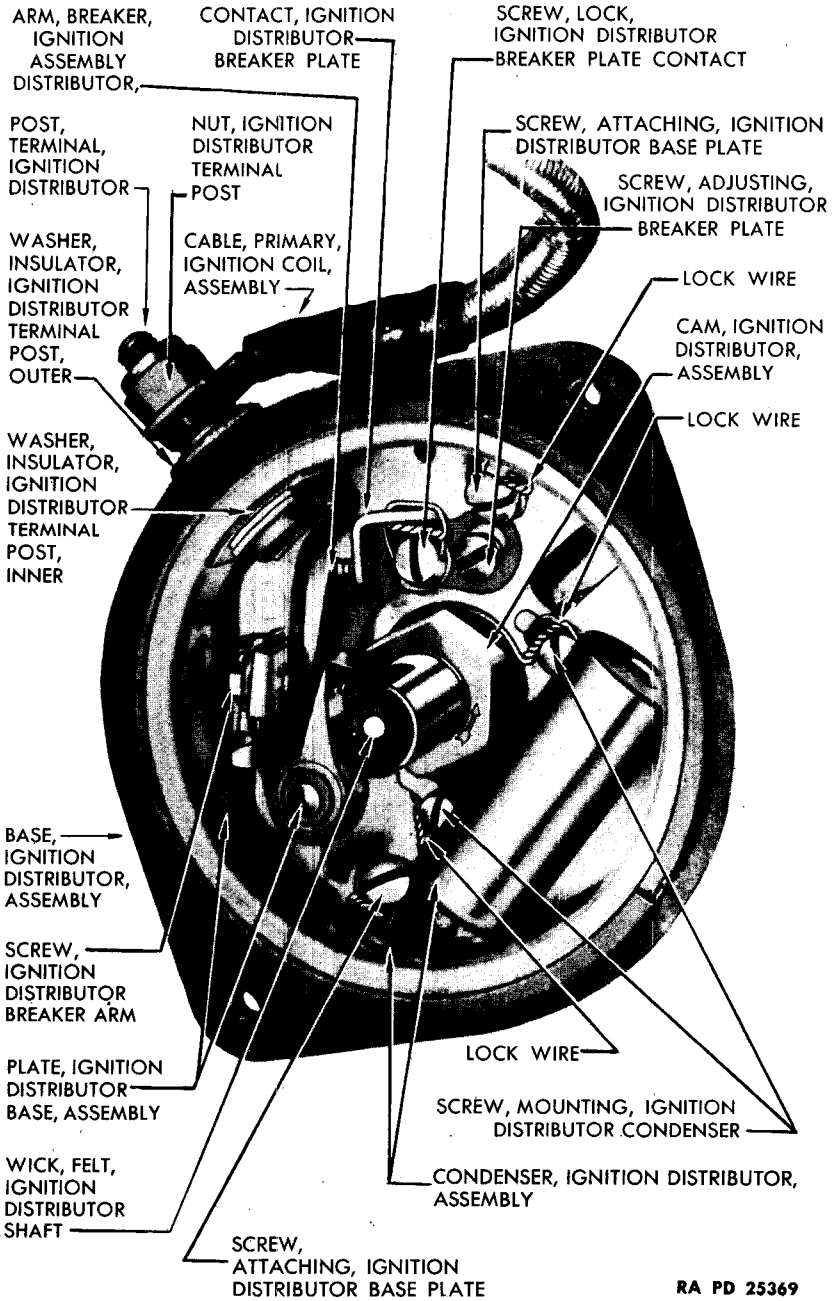
IGNITION DISTRIBUTOR

- A—CAP, IGNITION DISTRIBUTOR, ASSEMBLY
- B—ROTOR, IGNITION DISTRIBUTOR, ASSEMBLY
- C—PLATE, IGNITION DISTRIBUTOR SEAL, ASSEMBLY
- D—WASHER, LOCK, IGNITION DISTRIBUTOR BASE PLATE SCREW
- E—SCREW, ATTACHING, IGNITION DISTRIBUTOR CONDENSER
- F—CONDENSER, IGNITION DISTRIBUTOR, ASSEMBLY
- G—CLIP, IGNITION DISTRIBUTOR
- H—PLATE, IGNITION DISTRIBUTOR BREAKER, ASSEMBLY
- I—CAM, W/PLATE, IGNITION DISTRIBUTOR, ASSEMBLY
- J—SHAFT, W/GOVERNOR, IGNITION DISTRIBUTOR DRIVE, ASSEMBLY
- K—WEIGHT, IGNITION DISTRIBUTOR, ASSEMBLY
- L—WASHER, THRUST, DISTRIBUTOR SHAFT
- M—KEY, IGNITION DISTRIBUTOR
- N—RIVET, IGNITION DISTRIBUTOR DRIVE
- O—GEAR, IGNITION DISTRIBUTOR FOLLOWER
- P—WASHER, IGNITION DISTRIBUTOR DRIVE SHAFT AND GOVERNOR THRUST
- Q—BASE, IGNITION DISTRIBUTOR, ASSEMBLY
- R—GASKET, IGNITION DISTRIBUTOR BASE PLATE
- S—SHAFT, IGNITION DISTRIBUTOR DRIVE, ASSEMBLY
- T—SPRING, IGNITION DISTRIBUTOR GOVERNOR WEIGHT GROUP, ASSEMBLY
- U—SPACER, IGNITION DISTRIBUTOR DRIVE SHAFT AND GOVERNOR
- V—RING, LOCKING, IGNITION DISTRIBUTOR DRIVE SHAFT GOVERNOR END CAM
- W—WASHER, IGNITION DISTRIBUTOR INSULATING, OUTER
- X—WASHER, PLAIN, IGNITION DISTRIBUTOR
- Y—NUT, IGNITION DISTRIBUTOR TERMINAL POST
- Z—WASHER, LOCK, IGNITION DISTRIBUTOR TERMINAL POST
- AA—BUSHING, IGNITION DISTRIBUTOR INSULATING
- BB—INSULATOR, IGNITION DISTRIBUTOR TERMINAL POST
- CC—CLAMP, IGNITION DISTRIBUTOR TERMINAL POST
- DD—SCREW, IGNITION DISTRIBUTOR BREAKER ARM SPRING CLIP
- EE—CLIP, IGNITION DISTRIBUTOR BREAKER ARM SPRING
- FF—POST, IGNITION DISTRIBUTOR TERMINAL
- GG—ARM, BREAKER, IGNITION DISTRIBUTOR, ASSEMBLY
- HH—CONTACT, IGNITION DISTRIBUTOR BREAKER PLATE
- II—WASHER, IGNITION DISTRIBUTOR BREAKER PLATE SCREW
- JJ—SCREW, IGNITION DISTRIBUTOR BREAKER PLATE
- KK—SCREW, ATTACHING, IGNITION DISTRIBUTOR BASE PLATE
- LL—WASHER, LOCK, IGNITION DISTRIBUTOR SEAL PLATE MOUNTING SCREW
- MM—SCREW, IGNITION DISTRIBUTOR SEAL PLATE MOUNTING
- NN—GASKET, IGNITION DISTRIBUTOR CAP
- OO—SCREW, ATTACHING, IGNITION DISTRIBUTOR CAP
- PP—WASHER, LOCK, IGNITION DISTRIBUTOR CAP ATTACHING SCREW

RA PD 25355B

*Legend For Figure 206 — Ignition Distributor, Exploded*

**ORDNANCE MAINTENANCE – POWER UNIT FOR  
MEDIUM TANKS M3A4 AND M4A4**



RA PD 25369

**Figure 207 – Ignition Distributor, Interior**

## IGNITION DISTRIBUTOR

### (7) REMOVE DRIVE SHAFT BEARINGS.

PRESS, arbor

Place distributor base on press and, with suitable arbor, press bearings out.

## 58. INSPECTION AND REPAIR.

### a. Equipment.

TESTER, condenser, Federal PAN, for washing parts  
Stock No. 17-T-5520

### b. Procedure.

(1) Clean all parts thoroughly by wiping with a clean rag. Where necessary clean with SOLVENT, dry-cleaning.

(2) Inspect distributor cap for cracks, carbon runners, corroded high-tension terminals, excessively burned inserts inside of cap. NOTE: Slightly burned inserts can be cleaned with SOLVENT, dry-cleaning. *Do not file.*

(3) Inspect rotor for cracks or evidence of burning on the top of the metal strip. If slightly burned, clean with SOLVENT, dry-cleaning. Burning of strip indicates that strip is too short.

(4) Check condenser for both leakage and capacity (condenser tester, Federal Stock No. 17-T-5520 (fig. 209) ). The purpose of the condenser is to prevent excessive arcing. Breaker contact pitting will result if incorrect condenser is used. If crater is on the positive contact (breaker contact plate), the condenser is over capacity, while if crater is on the negative contact (breaker arm), the condenser is under capacity. Use new condenser to correct, which has slightly lower or higher capacity as the condition requires. Under ordinary circumstances, new standard condenser will be correct.

## 59. ASSEMBLY.

### a. Equipment.

HAMMER, 2-lb	WRENCH, open-end, $\frac{1}{4}$ -in.
PLIERS, side-cutting	WRENCH, open-end, $\frac{9}{16}$ -in.
PRESS, arbor	WRENCH, socket, $\frac{1}{4}$ -in.
SCREWDRIVER	

### b. Procedure.

#### (1) INSTALL DRIVE SHAFT BEARINGS.

PRESS, arbor

Place distributor base on press and, with suitable arbor, press bearings into place. NOTE: Bearings should be soaked in medium engine oil before assembly in base.

ORDNANCE MAINTENANCE – POWER UNIT FOR  
MEDIUM TANKS M3A4 AND M4A4

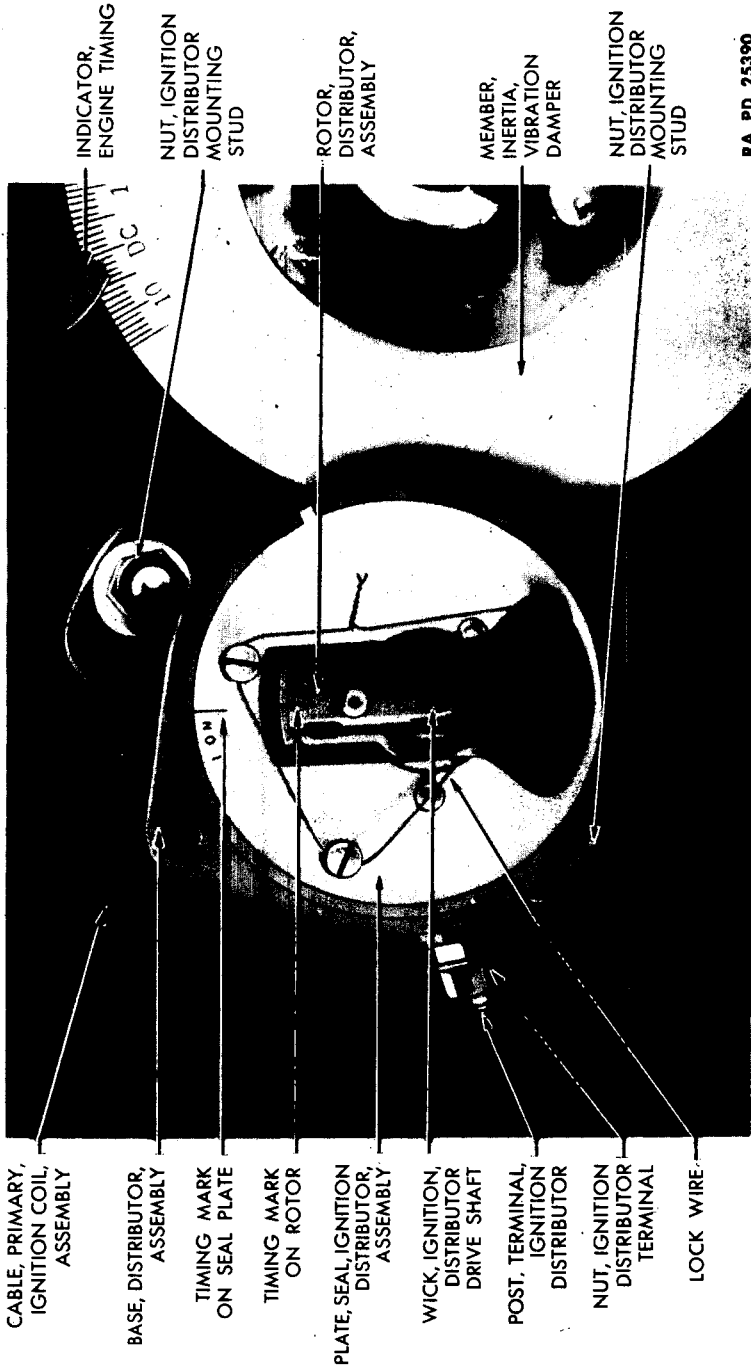


Figure 208 — Ignition Timing

**IGNITION DISTRIBUTOR****(2) INSTALL DRIVE SHAFT, CAM AND GOVERNOR ASSEMBLY.**

Place cam on drive shaft and push into place. Install thrust washer in base and slide shaft and governor assembly into place (fig. 206). Check for shaft side play which should not be over 0.005-inch. If side play is excessive, remove old bearings and install new. Recheck for side play. Put one drop of light oil in governor weight pivots and slots.

**(3) INSTALL CONDENSER IN DISTRIBUTOR BASE PLATE (fig. 207).****PLIERS**, side-cutting**SCREWDRIVER**

Position condenser in base plate and secure with 2 screws (screwdriver). Install lock wires (side-cutting pliers).

**(4) INSTALL BREAKER ARM AND BREAKER ARM CONTACT PLATE IN BASE PLATE (fig. 207).****SCREWDRIVER****WRENCH**, socket,  $\frac{1}{4}$ -in.

Place new breaker contact plate over post. Secure temporarily with screw and lock washer (screwdriver). Install new breaker arm over post and secure with breaker arm screw ( $\frac{1}{4}$ -in. socket wrench), after placing condenser lead in position. Hold breaker contacts apart while installing breaker arm to avoid damage to contacts. Install lock wire, to secure breaker arm screw (side-cutting pliers). Check contacts for alinement and that contact is made near center. Bend stationary contact bracket to secure proper alinement. Do not bend the breaker arm. Place one drop of light oil on breaker arm hinge pin. **NOTE:** Do not put more than one drop of oil on pin.

**(5) INSTALL DISTRIBUTOR BASE PLATE (fig. 206).****PLIERS**, side-cutting**WRENCH**, open-end,  $\frac{9}{16}$ -in.**SCREWDRIVER**

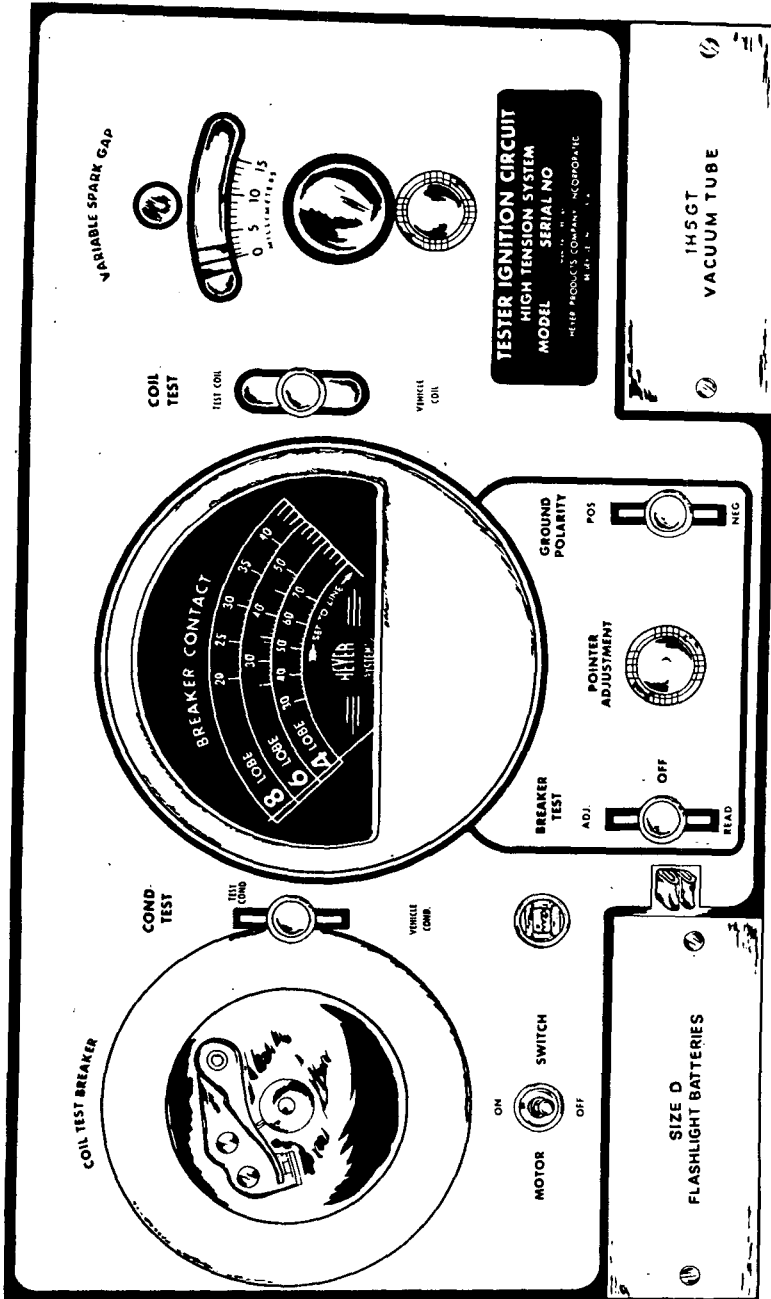
Install new gasket and position base plate in distributor base. Install terminal post clip and insulating washer and slide terminal post through plate. Install insulating bushing, insulating washer, plain washer, lock washer and secure with terminal nut ( $\frac{9}{16}$ -in. open-end wrench). Secure base plate with 2 screws and lock washers (screwdriver) and replace lock wires (side cutting pliers).

**(6) CHECK BREAKER ARM SPRING TENSION (fig. 210).****SCALE**, spring, Federal Stock  
No. 41-T-3583-55**WISE**, copper jaws**WRENCH**, open-end,  $\frac{1}{4}$ -in.

Place distributor in vise with copper jaws. Hook spring scale on breaker arm at the contacts and hold at right angles to the contact surfaces. Take a reading as breaker contacts separate. Reading should be 17 to 20 ounces. Adjust by removing lock wire (side-cutting pliers) and loosening breaker arm screw ( $\frac{1}{4}$ -in. open-end wrench) and slide end of spring in or out as



ORDNANCE MAINTENANCE - POWER UNIT FOR  
MEDIUM TANKS M3A4 AND M4A4



RA PD 25442

Figure 209 - Ignition Circuit (High Tension) Tester Federal Stock No. 17-T-5520

IGNITION DISTRIBUTOR

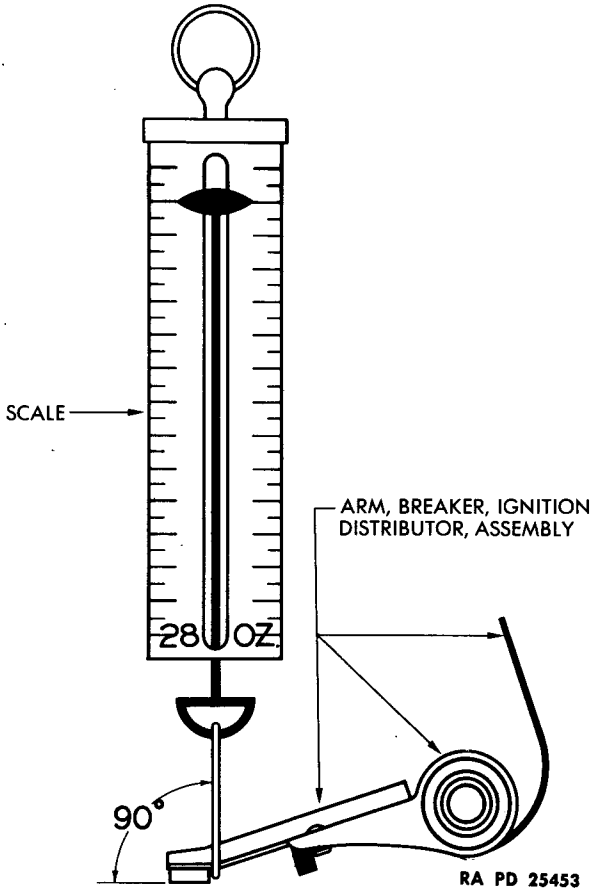


Figure 210 – Checking Breaker Arm Spring Tension

necessary. Retighten screw ( $\frac{1}{4}$ -in. open-end wrench), and replace lock wire (side-cutting pliers). Recheck spring pressure. Low tension produces “chatter” at high speeds. High pressure produces excessive wear of cam and breaker arm rubbing block.

(7) ADJUST BREAKER CONTACT GAP.

GAGE, thickness, 0.020-in.

SCREWDRIVER

PLIERS, side-cutting

VICE, copper jaws

Place distributor in vise with copper jaws. Loosen breaker plate lock screw (screwdriver). Turn cam until breaker arm is at a maximum opening (rubbing block on high point on cam). Use screwdriver and turn adjusting screw until 0.020-inch feeler gage will just fit gap. Tighten lock screw and recheck gap. Install lock wire through lock screw (side-cutting pliers). Place a light wipe of grease on each lobe of breaker cam.

**ORDNANCE MAINTENANCE – POWER UNIT FOR  
MEDIUM TANKS M3A4 AND M4A4**

**(8) INSTALL DISTRIBUTOR SEAL PLATE (fig. 208).**

**PLIERS**, side-cutting

**SCREWDRIVER**

Install seal plate and secure with 3 screws and lock washers (screwdriver). Install lock wire through screw heads (side-cutting pliers). Place 1 drop of light oil on wick in center of drive shaft.

**(9) INSTALL FOLLOWER GEAR (fig. 206).**

**DRIFT**

**HAMMER**, 2-lb

Place thrust washer on shaft and install gear in place on shaft. Drive new rivet into place with hammer. **NOTE:** Make sure rivet swells to fill hole and that both ends are swedged over. Check for end play of drive shaft. If not within limits of 0.003-inch to 0.010-inch remove gear and install thrust washers necessary to correct.

**60. GOVERNOR ADJUSTMENT.**

**NOTE:** No attempt at adjustment should be made except with a suitable distributor test fixture which will show the spark advance in degrees at the correct revolutions per minute.

a. Place distributor in test fixture.

b. Run the distributor at 350 revolutions per minute and set dial at "ZERO" degrees.

c. Increase the speed up to 1,530 revolutions per minute. Degree reading should be between 11 and 13 degrees.

d. If maximum advance is not within limits, reduce speed to below that required for zero degrees. Note whether degree indication drops below "ZERO."

e. If an indication below "ZERO" is shown, the outer spring bracket, on which the weak spring is connected, should be bent out slightly, and the distributor again checked at the maximum revolutions per minute.

f. If there is no indication below "ZERO," relieve the tension slightly on the strong spring. Then recheck at the maximum revolutions per minute.

g. Check the advance at the intermediate points shown in paragraph 64.

h. Check advance both up and down the speed range. Any variation in the two checks is due to friction in the assembly and should be corrected.

**61. DISTRIBUTOR BREAKER CONTACTS, CHECK AND ADJUSTMENT.**

a. When the breaker contacts are the only parts of the distributor to be checked, follow the procedure below:

## IGNITION DISTRIBUTOR

### (1) TOOLS.

FILE, contact  
GAGE, thickness 0.020-in.

PLIERS, side-cutting  
SCREWDRIVER

### (2) EQUIPMENT.

#### (a) *Remove Distributor Seal Plate* (fig. 208).

PLIERS, side-cutting  
SCREWDRIVER

Remove lock wire (side-cutting pliers). Remove 3 screws securing seal plate (screwdriver) and lift out plate.

#### (b) *Clean Distributor Breaker Contacts.*

FILE, contact

**NOTE:** Filing of distributor contacts is, at best, only a temporary procedure. If contacts are pitted, replace with new contacts. Hold breaker contacts apart to inspect and, if necessary, clean up squarely with contact file. **CAUTION:** Never clean distributor contacts with emery cloth or sandpaper.

(c) *Open Breaker Contacts.* Rotate distributor cam until contacts have their greatest opening.

#### (d) *Adjust Breaker Contacts.*

GAGE, thickness, 0.020-in.  
PLIERS, side-cutting

SCREWDRIVER

1. Remove locking wire (side-cutting pliers) from stationary contact point lock screw and loosen screw (screwdriver).

2. Turn stationary breaker contact adjusting screw, as needed to allow a 0.020-inch feeler gage to pass between the 2 contacts. Tighten lock screw (screwdriver) and lock with wire (side-cutting pliers) and again check clearance (0.020-in. feeler gage) to make sure adjustment has not been altered. **NOTE:** If clearance between contacts was altered in excess of 0.010 inch, check the ignition timing (par. 63).

#### (e) *Install Distributor Seal Plate* (fig. 208).

PLIERS, side-cutting  
SCREWDRIVER

Install seal plate and secure with 3 screws (screwdriver). Install lock wire through screw heads (side-cutting pliers).

## 62. INSTALLATION.

a. Procedure for installation of distributor on engine is covered in TM 9-754, paragraph 66 d.

## 63. IGNITION TIMING.

a. Procedure for timing the ignition is covered in TM 9-754, paragraph 67.

ORDNANCE MAINTENANCE — POWER UNIT FOR  
MEDIUM TANKS M3A4 AND M4A4

Section V

**LIMITS AND TOLERANCES**

Paragraph  
64

Limits and tolerances.....

**64. LIMITS AND TOLERANCES.**

	Minimum	Maximum
Spark plug gap.....	0.024 in.	0.027 in.
Breaker contact gap.....	0.020 in.	0.020 in.
Condenser capacity .....	0.020 microfarad	0.24 microfarad
Timing with vibration damper.....	4 deg BTDC	4 deg BTDC
Timing, at 1,300 rpm, with neon light .....	14 deg BTDC	14 deg BTDC
Breaker arm spring tension.....	17 oz	20 oz
Distributor shaft end play.....	0.003 in.	0.010 in.
Distributor shaft side play.....		0.005 in.
Automatic advance distributor rpm and distributor deg		
350 rpm.....	-1	+1
400 rpm.....	+2	+4
780 rpm.....	+5	+7
1,160 rpm.....	+8	+10
1,530 rpm.....	+11	+13

CHAPTER 4

REFERENCES

	Paragraph
Standard nomenclature lists .....	65
Explanatory publications .....	66

65. STANDARD NOMENCLATURE LISTS.

a. Armament.

- Gun, machine, cal. .30, Browning M1919A4, fixed and flexible, and M1919A5, fixed; and ground mounts ..... SNL A-6
- Gun, machine, cal. .50, Browning, M2, heavy barrel, fixed and flexible; and ground mounts..... SNL A-39
- Gun, submachine, cal. .45, Thompson, M1928A1 and M1 ..... SNL A-32
- Gun, 37-mm, M5 and M6; and cradle, tank, 37-mm, T2 ..... SNL A-45
- Gun, 75-mm, M2 and M3 (tank); and mount, gun, 75-mm, M1 ..... SNL C-34

b. Maintenance.

- Cleaning, preserving and lubricating materials; recoil fluids, special oils, and miscellaneous related items ..... SNL K-1
- Soldering, brazing and welding material, gases and related items ..... SNL K-2
- Tools, maintenance, for repair of automatic guns, automatic gun antiaircraft materiel, automatic and semiautomatic cannon, and mortars..... SNL A-35
- Truck, small-arms repair, M1 ..... SNL G-72

c. Tank, Medium, M4A4 ..... SNL G-104  
Vol. IX

Current Standard Nomenclature Lists are as tabulated here. An up-to-date list of SNL's is maintained as the "Ordnance Publications for Supply Index"..... OPSI

**ORDNANCE MAINTENANCE — POWER UNIT FOR  
MEDIUM TANKS M3A4 AND M4A4**

**66. EXPLANATORY PUBLICATIONS.****a. Armament.**

Browning machine gun, cal. .30, HB, M1919A4 (mounted in combat vehicles) .....	FM 23-50
Browning machine gun, cal. .50, HB, M2 (mounted in combat vehicles) .....	FM 23-65
Grenades .....	FM 23-30
Instruction guide: Small-arms data .....	TM 9-2200
Ordnance maintenance: 37-mm gun materiel (tank) M5 and M6 .....	TM 9-1250
Thompson submachine gun, cal. .45, M1928A1....	FM 23-40
37-mm gun, tank, M6 (mounted in tanks) .....	FM 23-81
75 mm-gun materiel, M2 and M3 (tank) .....	TM 9-307

**b. Communications.**

Radio fundamentals .....	TM 11-455
Radio set SCR 506 .....	TM 11-630
Radio sets SCR 508, SCR 528 and SCR 538 .....	TM 11-600
The radio operator .....	TM 11-454

**c. Maintenance.**

Automotive brakes .....	TM 10-565
Automotive electricity .....	TM 10-580
Automotive lubrication .....	TM 10-540
Automotive power transmission units .....	TM 10-585
Chassis, body and trailer units .....	TM 10-560
Cleaning, preserving, lubricating, and welding materials and similar items issued by the Ordnance Department .....	TM 9-850
Defense against chemical attack .....	FM 21-40
Detailed lubrication instructions for ordnance materiel .....	OFSB 6-series
Echelon system of maintenance .....	TM 10-525
Fire prevention, safety precautions, accidents.....	TM 10-360

REFERENCES

- |  |            |
|--|------------|
| Motor transport inspections .....  | TM 10-545  |
| Ordnance maintenance: Power train unit, three-piece differential case for Medium Tanks M3, M4, and modifications .....   | TM 9-1750  |
| Ordnance maintenance: Stabilizers, all types.....  | TM 9-1798A |
| Sheet metal work, body, fender and radiator repairs .....  | TM 10-450  |
| The motor vehicle .....  | TM 10-510  |
| Tune-up and adjustment .....   | TM 10-530  |
| <br>   |            |
| <b>d. Miscellaneous.</b>   |            |
| Camouflage .....   | FM 5-20    |
| Electric fundamentals .....  | TM 1-455   |
| Fuels and carburetion .....  | TM 10-550  |
| List of publications for training .....  | FM 21-6    |
| Military motor transportation .....  | TM 10-505  |
| Military motor vehicles .....  | AR 850-15  |
| Motor transport .....  | FM 25-10   |
| The internal combustion engine .....   | TM 10-570  |
| <br>   |            |
| <b>e. Storage And Shipment.</b>  |            |
| Rules governing the loading of mechanized and motorized Army equipment, also, major calibre guns for the United States Army and Navy, on open top equipment — Published by the Operations and Maintenance Department of the Association of American Railroads. |            |
| Storage of military motor vehicles .....   | AR 850-18  |



**ORDNANCE MAINTENANCE – POWER UNIT FOR  
MEDIUM TANKS M3A4 AND M4A4**

**INDEX**

<b>A</b>	<b>Page No.</b>	<b>A</b>	<b>Page No.</b>
Abnormal vibration of power unit	60	installation	133-137
Accessory drive gears, assembly	171-175	limits and tolerances	254
Accessory drive shaft		removal	82
inspection	100	Camshaft and camshaft gear	
installation	124, 175-177	alinement	90
limits and tolerances	257	inspection	90-91
Adjustments:		Camshaft bearings	
distributor breaker contacts	298-299	installation	106-109
governor	298	removal	106
prior to power test	246-250	Camshaft timing gears, limits and tolerances	256
spark plugs	287	Carburetor	
Adjustments and tests of power unit		installation	230
dynamometer test, equipment		packing for shipment	268-270
required for	241-244	Cautions:	
final adjustments and assembly	251-252	assembly of engine	185
general discussion of	241	installation of distributor tube	
performance test	244-251	plugs	85
Alinement		oilhole alinement	139-141
camshaft and camshaft gear	90	power unit operation after	
connecting rod	114	submersion	262
crankshaft and crankshaft gear	88-89	Characteristics of power unit	3-6
Ammunition boxes and racks, maintenance duties by echelons	7	Cleaning:	
Assembly		connecting rod	91
accessory drive shaft gear	171-175	crankcase	169
connecting rod and piston	111-114	cylinder head	87-88
engine drive gear	202	ignition distributor	293
exhaust manifold	115-121	manifolds	98
ignition distributor	293-298	piston and rings	95-98
individual engine	125-168	spark plugs	287
intake manifold	124	valves	93
power unit	169-240	Cold, operation of materiel in	261
components	111-124	Connecting rod	
<b>B</b>		alinement	114
Backfiring of power unit	277	assembly	111-114
Backlash, checking in distributor		cleaning	91
drive gear	157	description	27-33
Bore, length of	42	inspection	91-93
Bracket and lever control, maintenance duties by echelons	7	limits and tolerances	254
<b>C</b>		Controlled differential, maintenance duties by echelons	7-10
Camshaft		Cooling system, filling after storage or shipment	272
data on	43	Crankcase	
description	33	cleaning	169
		description	20

INDEX

<b>C — Cont'd</b>		<b>Page No.</b>	<b>Page No.</b>
Crankshaft and bearing			
description .....	27	power unit .....	63-76
limits and tolerances .....	254-255	components .....	109-111
Crankshaft and crankshaft gear		Distributor	
alinement .....	88-89	installation .....	166-168
data on .....	49	limits and tolerances .....	257
inspection .....	88-90	Distributor breaker contacts,	
Cylinder bore, reconditioning.....	100-102	adjustment .....	298-299
Cylinder block		Distributor drive gear, checking	
description .....	27	backlash in .....	157
inspection .....	83-87	Drive gear case, limits and	
Cylinder head		tolerances .....	257
cleaning .....	87-88	Drive gear housing, removal .....	70
description .....	27	Dust, operation of materiel in.....	261
inspection .....	87-88	Dynamometer stand, removal of	
Cylinders, limits and tolerances.....	255	power unit from .....	252
		Dynamometer test .....	250-251
		equipment required .....	241-244
		<b>D</b>	<b>E</b>
Data			
ignition system .....	275	Echelon breakdown of main-	
individual engine .....	43-53	tenance .....	275
power unit .....	42-43	Electrical system, maintenance	
Description		duties by echelons .....	11
camshaft .....	33	Engine rotation .....	20
connecting rod and bearings.....	27-33	Engine drive gear	
crankcase .....	20	assembly .....	202
crankshaft and main bearing .....	27	installation .....	202-208
cylinder block .....	27	Engine tools, special, list of .....	259-260
cylinder head .....	27	Exhaust manifold, assembly.....	115-121
high-tension wiring harness.....	287	Exhaust valves, limits and	
ignition coil .....	287	tolerances .....	256
ignition distributor .....	288		
ignition filter .....	286	<b>F</b>	
ignition solenoid switch .....	286	Failures of power unit .....	276
instrument box ignition switch.....	286	Final drive, maintenance duties	
manifold .....	42	by echelons .....	7
pistons .....	42	Final reduction, maintenance	
power unit .....	19-42	duties by echelons .....	10
ignition system .....	273-275	Fire extinguishing system, main-	
spark plug .....	287	tenance duties by echelons .....	15-16
timing gears .....	33-37	Fuel pump	
valve mechanism .....	37-42	installation .....	168
Diagnosis and test of power		location .....	3
unit .....	277-285	pressure of .....	248
Disassembly		removal .....	69
ignition distributor .....	289-293		
individual engine .....	77-82	<b>G</b>	
intake manifold .....	110	Gear case cover, installation.....	154-157
piston and connecting rods .....	109	Generator, installation .....	227-230

**ORDNANCE MAINTENANCE — POWER UNIT FOR  
MEDIUM TANKS M3A4 AND M4A4**

<b>H</b>	<b>Page No.</b>		<b>Page No.</b>
Heat, operation of materiel in.....	261	Instruments and panels, main-	
High-tension wiring harness,		tenance duties by echelons .....	16
description .....	287	Intake and exhaust manifold	
Hull, maintenance duties by		disassembly .....	109
echelons .....	16	installation .....	162-163
		Intake manifold	
<b>I</b>		assembly .....	124
Idling adjustment .....	248	disassembly .....	110
Idling of power unit .....	60	Intake valve, limits and tolerances...	256
Ignition coil, description .....	287		
Ignition distributor		<b>L</b>	
assembly .....	293-298	Length of bore .....	42
breaker contacts, check and		Limits and tolerances	
adjustment .....	298-299	ignition distributor .....	300
description .....	288	power unit .....	254-258
disassembly .....	289-293	Lubrication	
governor adjustment .....	298	power unit .....	23
ignition timing .....	299	timing gears .....	37
inspection and repair .....	293	Lubrication system	
installation .....	299	inspection and test .....	83
limits and tolerances .....	300	maintenance duties by echelons....	16
removal .....	288		
Ignition filter		<b>M</b>	
description .....	286	Maintenance, allocation of .....	6-18
inspection and repair .....	287	Manifolds	
removal and installation .....	287	cleaning and inspection .....	98
Ignition solenoid switch,		description .....	42
description and operation .....	286	Marking parts for reassembly.....	63
Individual engine		Maximum torque .....	251
assembly .....	125-168		
data .....	43-53	<b>N</b>	
disassembly .....	77-82	Neoprene cement, use of .....	132
trouble shooting .....	61	Number, serial of power unit.....	19
Inspection		<b>O</b>	
accessory drive shaft .....	100	Oil filters, installation .....	233
camshaft and camshaft gear.....	90-91	Oil pressure, low .....	59
connecting rod .....	91-93	Oil pump, installation.....	191
crankshaft and crankshaft gear...	88-90	Operation	
cylinder block .....	83-87	cold and hot weather .....	261
cylinder head .....	87-88	ignition solenoid switch .....	286
ignition distributor .....	293	instrument box ignition switch ...	286
ignition filter .....	287	materiel under extreme con-	
lubricating system .....	83	ditions .....	261-262
manifolds .....	98	power unit ignition system.....	273-275
piston and ring .....	95-98	sand or dust.....	261
power unit components .....	83-100	submersion .....	262
valves .....	93-95	underbrush .....	261
Instrument box ignition switch,		Overheating of power unit.....	56-57
description and operation .....	286		

INDEX

P	Page No.	R	Page No.
Performance test, run-in .....	244-246	Radiator coolant	
Piston and connecting rod		draining from water lines .....	265
disassembly .....	109	loss of .....	60
installation .....	137-141	Rebuild defined .....	7
Pistons		Repair defined .....	7
cleaning and inspection .....	95-98	Replace defined .....	7
data .....	48	Rotation of engine .....	20
description .....	42	Run-in test .....	244-246
limits and tolerances .....	255		
Power, lack of in power unit .....	56	<b>S</b>	
Power test, adjustments prior to .....	246-250	Sand, operation of materiel in.....	261
Power unit		Second echelon operations	
abnormal vibration .....	60	power unit .....	53
adjustments and tests .....	241-252	ignition system .....	275
assembly .....	169-240	Serial numbers of power unit.....	19
characteristics .....	3-6	Service defined .....	6
data and specifications .....	42-53	Shaft plug alinement tool .....	208
description .....	3, 19-42	Spark plugs	
disassembly .....	63-76	cleaning and adjusting .....	287
firing order .....	42	description .....	287
general discussion of .....	19	faulty .....	56
installation .....	252	removal .....	70
limits and tolerances .....	254-258	testing .....	246
lubrication .....	23	Specifications (See Data)	
maintenance duties by echelons .....	14-15	Standard limits and tolerances	
organization maintenance .....	6-18, 53	for tightening bolts .....	257-258
preparation for storage .....	271-272	Starter switch, defective .....	54
references .....	18	Storage, shipping, and packing	
removal .....	62	packing for shipment or storage .....	263-270
rustproofing interior of .....	263-264	power unit	
second echelon operation .....	53	preparations for service.....	271-272
serial numbers .....	19	unpacking .....	270-271
stopping .....	57	Submerged materiel, operation of.....	262
trouble shooting .....	54-61, 276-285		
unpacking from shipping box..	270-271	<b>T</b>	
weight of .....	263	Tabulated data (See Data)	
Power unit components, repair of .....	100-109	Test(-ing)	
Power unit drive gear housing,		lubricating system .....	83
lubrication .....	23	performance .....	244-251
Power unit ignition system		spark plugs .....	246
data and specifications .....	275	Timing gears	
description .....	273-275	data .....	49
echelon breakdown of maintenance .....	275	description .....	33-37
second echelon operation .....	275	lubrication .....	37
Precautions (See Cautions)		Tools, special, engine, list of.....	259-260
Propeller shaft and universal joint		Torque, maximum .....	251
assembly, maintenance duties		Track suspension system, mainte-	
by echelons .....	17	nance duties by echelons.....	17

**ORDNANCE MAINTENANCE — POWER UNIT FOR  
MEDIUM TANKS M3A4 AND M4A4**

<b>T — Cont'd</b>	<b>Page No.</b>	<b>Page No.</b>	
Transmission assembly, maintenance duties by echelons .....	10	Valve seat inserts regrinding .....	103-104
Trouble shooting		removal and installation .....	105
diagnosis and tests .....	277-285	Valve springs, limits and tolerances....	257
general discussion of .....	54, 276	Valve timing, data .....	52-53
individual engine .....	61	Valves	
power unit assembly .....	54-60	cleaning .....	93
symptoms .....	276-277	inspection .....	93-95
Turret assembly, maintenance duties		installation .....	141-143
by echelons .....	17	refacing .....	102
		Vehicle assembly, maintenance duties	
		by echelons .....	18
		<b>W</b>	
		Water pump	
		description .....	23-27
		installation .....	160-161
		limits and tolerances .....	257
		removal .....	72
		Weight of power unit .....	263
		Welch plug	
		installation .....	105-106
		removal .....	105

**U**

Underbrush operation of materiel in..	261
Uneven	
operation of power unit .....	56
running of power unit .....	277
Unpacking power unit.....	270-271

**V**

Valve covers, installation .....	159
Valve guide, removal and installation	103
Valve mechanism, description .....	37-42

[ A.G. 062.11 (3-19-43) ]

BY ORDER OF THE SECRETARY OF WAR:

G. C. MARSHALL,  
*Chief of Staff.*

OFFICIAL:

J. A. ULIO,  
*Major General,*  
*The Adjutant General.*

DISTRIBUTION:

R 9(2); Bn 9(1); C 9(4).

(For explanation of symbols, see FM 21-6)