

REGRADED UNCLASSIFIED BY  
AUTHORITY OF DOD DIR. 5200.1-R  
BY BAW/S ON 013106

TM 9-1743

UNCLASSIFIED

DECLASSIFIED  
Auth: NND 775120  
By NND 1002 3-30-75

WAR DEPARTMENT

# TECHNICAL MANUAL



ORDNANCE MAINTENANCE

**POWER TRAIN, SUSPENSION, HULL, AND  
TURRET FOR LIGHT ARMORED CAR M8  
AND ARMORED UTILITY CAR M20**

26 OCTOBER 1943

This record was previously  
allotted to RG 519 (Entry  
No. 382) and is now assigned  
to RG 287.

WASHINGTON, D. C.

JAN 21 1944  
 TECHNICAL MANUAL }  
 No. 9-1743

UNCLASSIFIED  
 WAR DEPARTMENT  
 Washington, 26 October 1943

## ORDNANCE MAINTENANCE

# POWER TRAIN, SUSPENSION, HULL, AND TURRET FOR LIGHT ARMORED CAR M8 AND ARMORED UTILITY CAR M20

*Dissemination of restricted matter.—The information contained in restricted documents and the essential characteristics of restricted materiel may be given to any person known to be in the service of the United States and to persons of undoubted loyalty and discretion who are cooperating in Government work, but will not be communicated to the public or to the press except by authorized military public relations agencies. (See also paragraph 18b, AR 380-5, 28 September 1942.)*

## CONTENTS

	Paragraphs	Pages
CHAPTER 1. INTRODUCTION .....	1-3	3-18
CHAPTER 2. TRANSMISSION .....	4-18	19-44
SECTION I Description and data .....	4-5	19-20
II Disassembly of transmission .....	6-11	21-25
III Transmission cleaning, inspection and repair .....	12-13	26-28
IV Assembly of transmission .....	14-18	29-44
CHAPTER 3. PROPELLER SHAFTS, UNIVERSAL JOINTS AND PILLOW BLOCK .....	19-30	45-56
SECTION I Description and data .....	19-20	45-46
II Propeller shafts and universal joints .....	21-26	47-52
III Pillow block .....	27-30	53-56
CHAPTER 4. TRANSFER CASE .....	31-50	57-84
SECTION I Description and data .....	31-32	57-59
II Disassembly of transfer case .....	33	60-63
III Transfer case cleaning, inspection and repair .....	34-42	64-75
IV Assembly of transfer case .....	43-50	76-84

**ORDNANCE MAINTENANCE—POWER TRAIN, SUSPENSION, HULL,  
AND TURRET FOR ARMORED CAR M8 AND UTILITY CAR M20**

		Paragraphs	Pages
CHAPTER	5. REAR AND INTERMEDIATE AXLES	51-70	85-102
SECTION	I Description and data	51-52	85-87
	II Disassembly of rear or intermediate axle	53-57	88-91
	III Rear and intermediate axle cleaning, inspection and repair	58-64	92-97
	IV Assembly of rear or intermediate axle	65-70	98-102
CHAPTER	6. FRONT AXLE	71-94	103-122
SECTION	I Description and data	71-72	103-105
	II Disassembly of front axle	73-78	106-108
	III Front axle cleaning, inspection, and repair	79-87	109-118
	IV Assembly of front axle	88-94	119-122
CHAPTER	7. BOGIE, SPRINGS, SHACKLES, AND SHOCK ABSORBERS	95-98	123-128
CHAPTER	8. STEERING GEAR	99-102	129-138
CHAPTER	9. BRAKES AND HUBS	103-108	139-146
CHAPTER	10. HULL AND TURRET	109-119	147-171
SECTION	I Description	109-110	147-149
	II Gun and gun mount for light armored car M8	111-112	150-153
	III Turret for light armored car M8	113-119	154-171
CHAPTER	11. FITS AND TOLERANCES, AND TOOLS	120-121	172-176
SECTION	I Fits and tolerances	120	172-173
	II Special tools	121	174-176
REFERENCES			177-178
INDEX			179

# **CHAPTER 1**

## **INTRODUCTION**

	<b>Paragraph</b>
<b>Scope</b> .....	<b>1</b>
<b>Arrangement</b> .....	<b>2</b>
<b>Maintenance allocation</b> .....	<b>3</b>

### **1. SCOPE.**

a. The instructions contained in this manual are for the information and guidance of personnel charged with the maintenance and repair of Light Armored Car M8 and Armored Utility Car M20. These instructions are supplementary to field and technical manuals prepared for the using arm. This manual does not contain information which is intended primarily for the using arm, since such information is available to ordnance maintenance personnel in 100-series TM's or FM's.

b. This manual contains a description of, and procedure for the disassembly, inspection, and repair of the transmission, propeller shafts, transfer case, all axles, bogies, springs, shock absorbers, steering gear, brakes, wheels, hubs, hull, and turret.

c. TM 9-743 contains information and instructions for personnel of the using arms charged with the operation, maintenance, and minor repair of the materiel.

d. TM 9-1832A contains ordnance maintenance instructions for Hercules engines used in these vehicles.

e. The Light Armored Car M8 and Armored Utility Car M20 are identical vehicles with the following exceptions: The M8 incorporates a cast-steel turret and is equipped with a 37-mm gun. The M20 has no turret, but instead is equipped with a ring mount, to which is secured a .50 caliber machine gun.

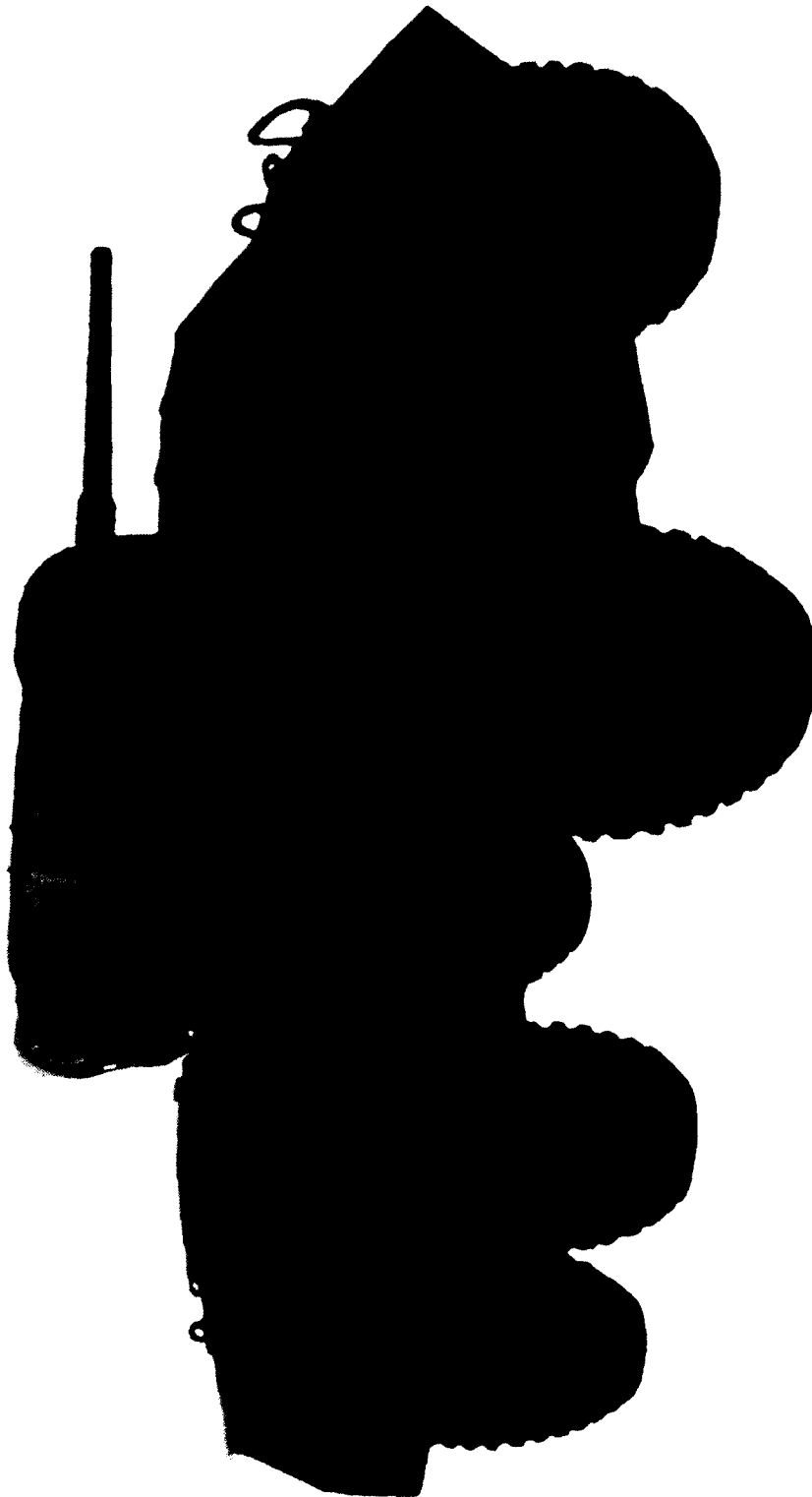
### **2. ARRANGEMENT.**

a. Separate chapters are provided for: Transmission, Propeller Shafts, Transfer Case, Rear and Intermediate Axles, Front Axle, Bogies, Steering Gear, Brakes and Hubs, and Hull and Turret. The major units in each of the above chapters are covered in individual sections where required. Chapter 11 contains a list of special tools necessary for disassembly, inspection, repair, and assembly of the various units.

### **3. MAINTENANCE ALLOCATION.**

a. **Scope.** The scope of maintenance and repair by the crew and

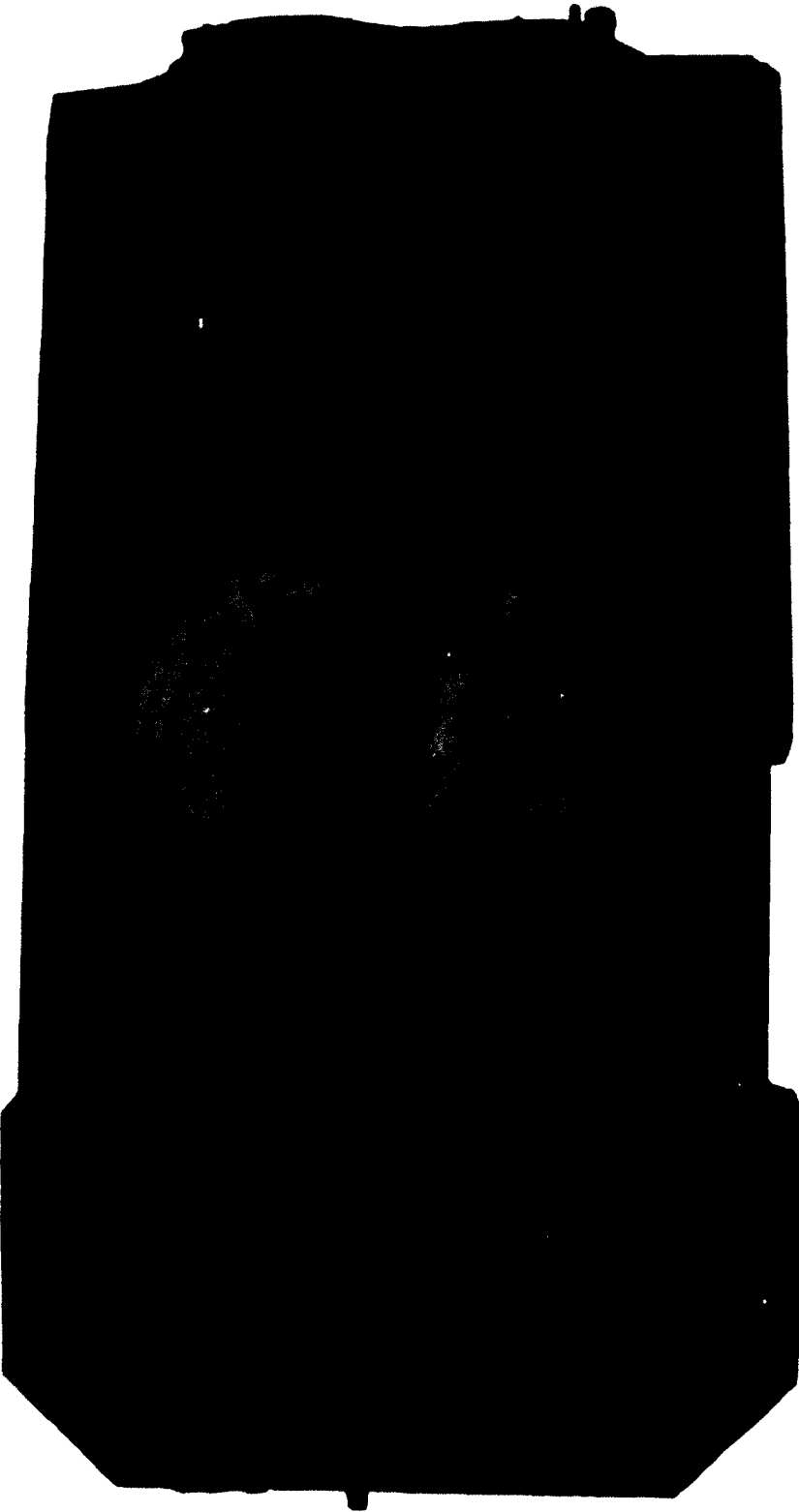
**ORDNANCE MAINTENANCE—POWER TRAIN, SUSPENSION, HULL,  
AND TURRET FOR ARMORED CAR M8 AND UTILITY CAR M20**



RA PD 27994

**Figure 1—Right Front View of Light Armored Car M8**

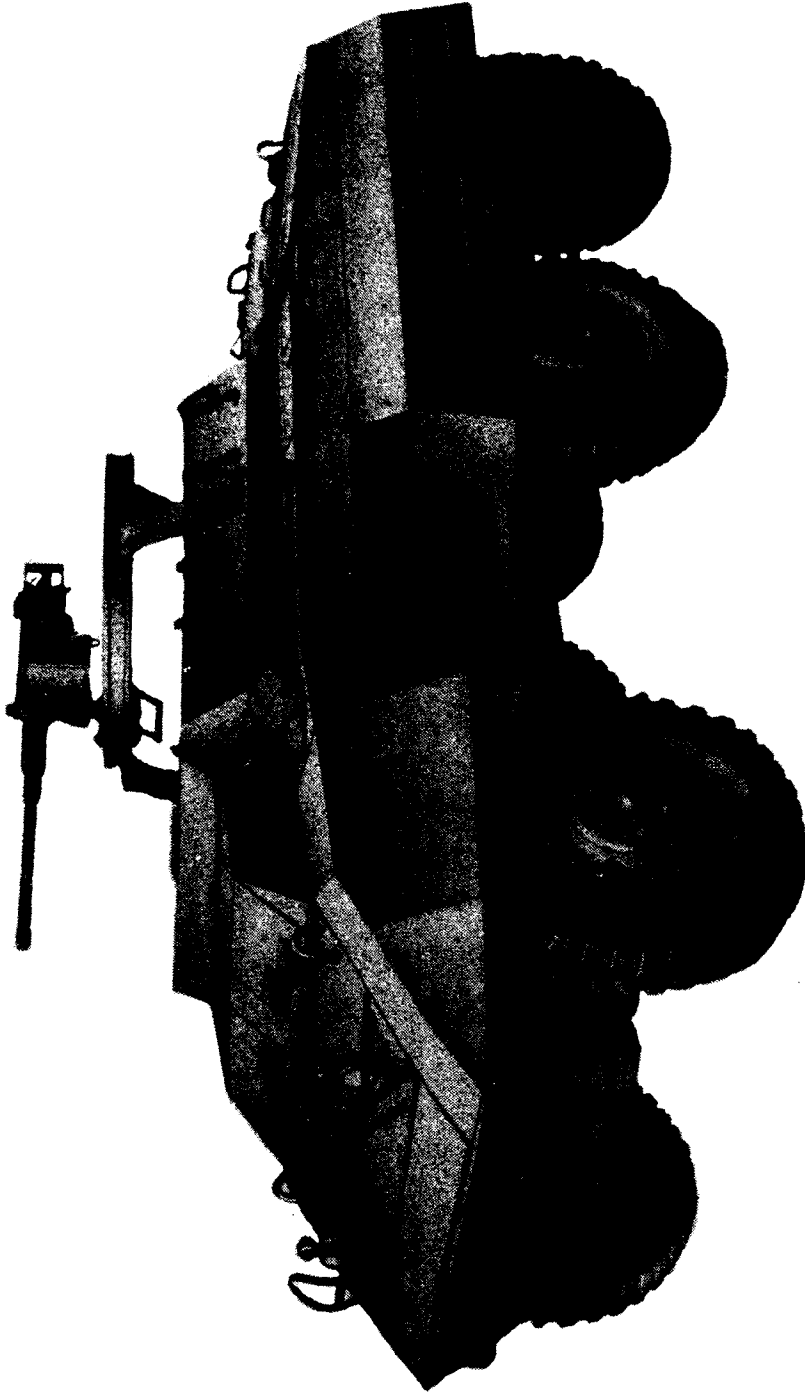
INTRODUCTION



RA PD 27996

**Figure 2—Light Armored Car M8 from Above**

**ORDNANCE MAINTENANCE—POWER TRAIN, SUSPENSION, HULL,  
AND TURRET FOR ARMORED CAR M8 AND UTILITY CAR M20**

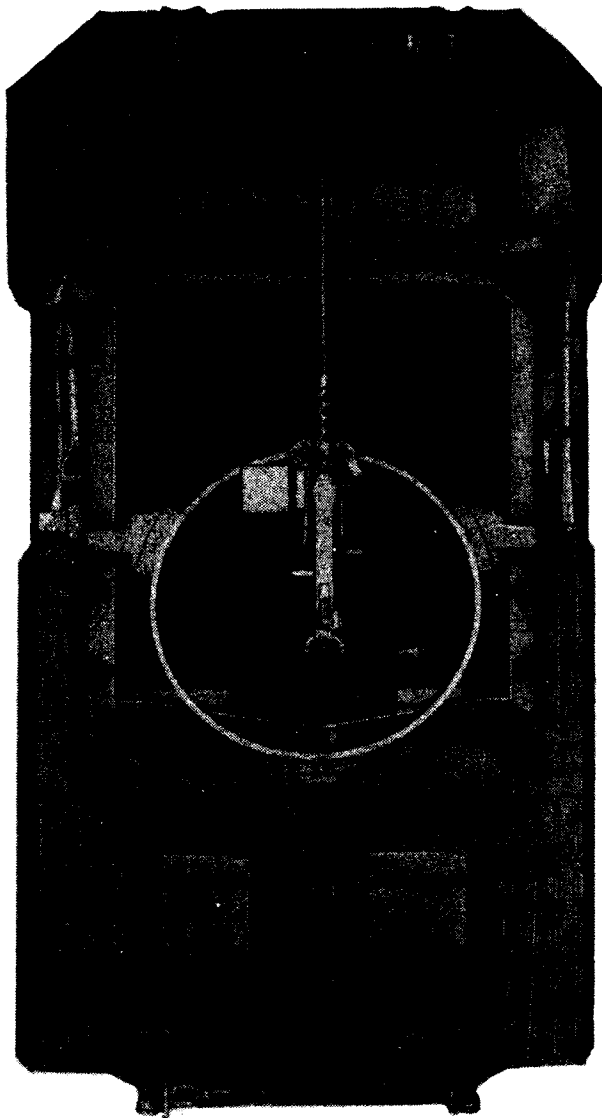


RA PD 28319

**Figure 3—Right Front View of Armored Utility Car M20**

INTRODUCTION

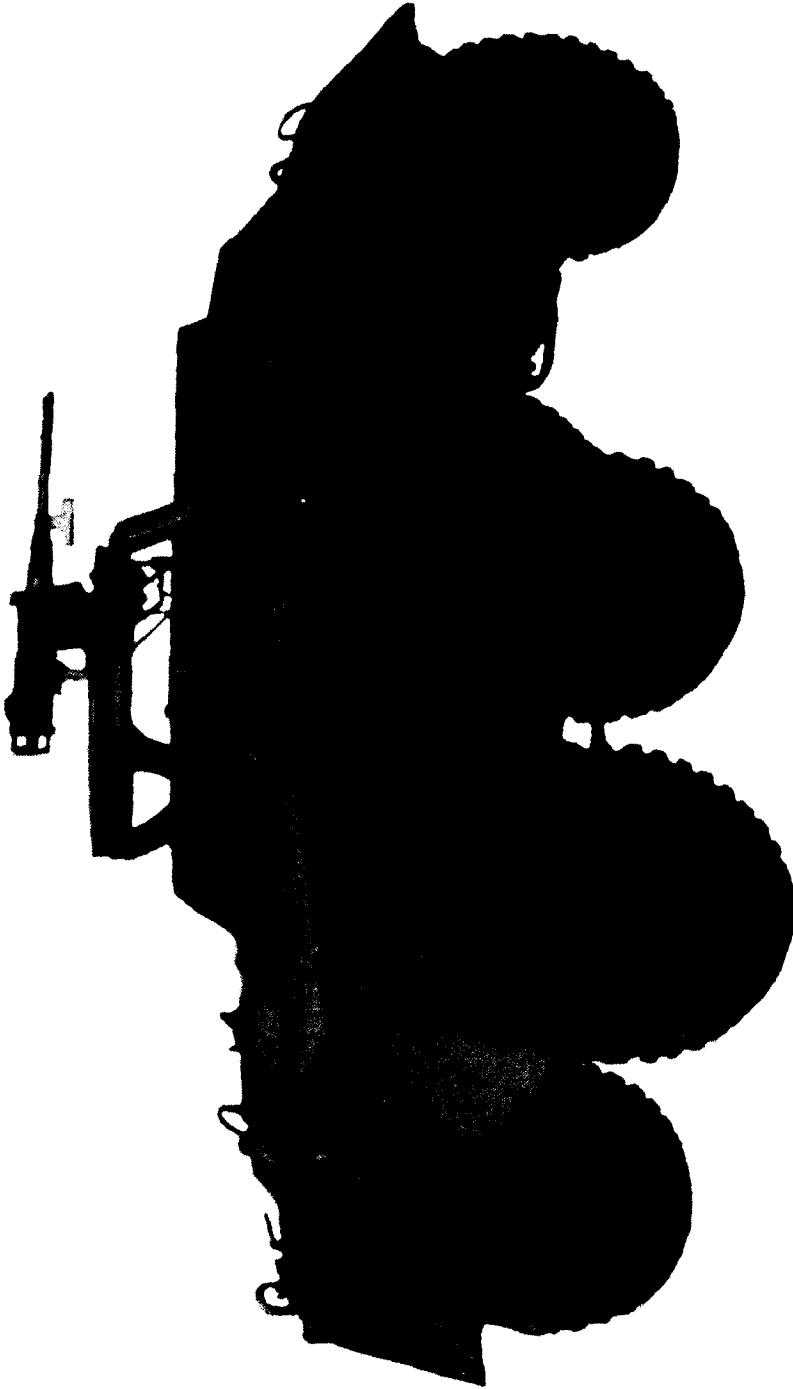
RA PD 28318



**Figure 4—Armored Utility Car M20 from Above**



**ORDNANCE MAINTENANCE—POWER TRAIN, SUSPENSION, HULL,  
AND TURRET FOR ARMORED CAR M8 AND UTILITY CAR M20**



RA PD 28320

*Figure 5—Right Rear View of Armored Utility Car M20*

## INTRODUCTION

other units of the using arms is determined by the availability of suitable tools, availability of necessary parts, capabilities of the mechanics, time available, and the tactical situation. All of these are variable and no exact system of procedure can be prescribed. Many second echelon operations are often done by ordnance personnel.

**b. Allocation of Maintenance.** Indicated below are the maintenance duties for which tools and parts have been provided for the using arm and ordnance maintenance personnel. Replacements and repairs which are the responsibility of ordnance maintenance personnel may be performed by using arm personnel when circumstances permit, within the discretion of the commander concerned. Echelons and words as used in this list of maintenance allocations are defined as follows:

<p><b>FIRST AND SECOND ECHELON:</b> Table III, AR 850-15</p>	<p>Operating organization driver, operator or crew, companies and detachments, battalions, squadrons, regiments, and separate companies and detachments (first and second echelons, respectively).</p>
<p><b>THIRD ECHELON:</b> Table III, AR 850-15</p>	<p>Technical light and medium maintenance units, including Post and Port Shops.</p>
<p><b>FOURTH ECHELON:</b> Table III, AR 850-15</p>	<p>Technical heavy maintenance and field depot units including designated post and service command shops.</p>
<p><b>FIFTH ECHELON:</b> Table III, AR 850-15</p>	<p>Technical base units.</p>
<p><b>SERVICE:</b> (Including preventive maintenance) par. 24 a (2) and (3) in part. AR 850-15</p>	<p>Checking and replenishing fuel, oil, grease, water and antifreeze, air, and battery liquid; checking and tightening nuts and bolts; cleaning.</p>
<p><b>REPLACE:</b> Par. 24 a (5) AR 850-15</p>	<p>To remove an unserviceable part, assembly, or subassembly from a vehicle and replace it with a serviceable one.</p>
<p><b>REPAIR:</b> Par. 24 a (6) in part AR 850-15</p>	<p>To restore to a serviceable condition, such parts, assemblies or subassemblies as can be accomplished without completely disassembling the assembly or subassembly, and where heavy riveting, or precision machining, fitting, balancing, or alining is not required.</p>

**ORDNANCE MAINTENANCE—POWER TRAIN, SUSPENSION, HULL,  
AND TURRET FOR ARMORED CAR M8 AND UTILITY CAR M20**

**REBUILD:** Par. 24 a (6) AR 850-15  
 Consists of stripping and completely reconditioning and replacing in serviceable condition any vehicle or unserviceable part, subassembly, or assembly of the vehicle, including welding, riveting, machining, fitting, alining, balancing, assembling, and testing.

**RECLAMATION:** AR 850-15  
 Par. 4 (c) in part CIR. 75, dated 16 March '43  
 Salvage of serviceable or economically repairable units and parts removed from vehicles, and their return to stock. This includes the process which recovers and/or reclaims unusable articles or component parts thereof and places them in a serviceable condition.

- NOTES:** (1) Operations allocated will normally be performed in the echelon indicated by X.  
 (2) Operations allocated to the third echelon as indicated by E may be performed by these units in emergencies only.  
 (3) Operations allocated to the fourth echelon by E are normally fifth echelon operations. They will not be performed by the fourth echelon, unless the unit is expressly authorized to do so by the chief of the service concerned.  
 (4) Consult reclamation bulletins for detailed information relative to reclamation procedure.

	ECHELONS			
	2nd	3rd	4th	5th
<b>ABSORBERS, SHOCK</b>				
Absorber assemblies, shock (w/linkage)— service and/or replace .....	X			
<b>AXLE, FRONT</b>				
*Axle assembly—replace .....	*	X		
Axle assembly—repair .....		X		
Axle assembly—rebuild .....			E	X
Bearings, wheel—service and/or replace .....	X			
Drums, brake—replace .....	X			
Hub assemblies—replace .....	X			
Hub assemblies—repair .....		X		
Hub assemblies—rebuild .....				X

**NOTE:** \*The second echelon is authorized to remove and reinstall items marked by an asterisk. However, when it is necessary to replace an item marked by an asterisk with a new or rebuilt part, subassembly or unit assembly, the assembly marked by an asterisk may be removed from the vehicle by the second echelon *only after authority has been obtained from a higher echelon of maintenance.*

**INTRODUCTION**

	<b>ECHELONS</b>			
	2nd	3rd	4th	5th
<b>AXLE, FRONT (Cont'd)</b>				
Hub and drum assembly—replace .....	X			
Retainers, wheel grease—replace .....	X			
Rod assembly, tie—replace .....	X			
Rod assembly, tie—repair .....		X		
Seals, oil trunnion housing—replace .....		X		
Shafts, axle—replace .....		X		
Wheel alinement, toe-in—adjust .....	X			
Wheel alinement, camber and caster—aline .....			E	X
<b>AXLES AND SUSPENSION, REAR (TANDEM)</b>				
*Axle assemblies—replace .....	*	X		
Axle assemblies—repair .....		X		
Axle assemblies—rebuild .....			E	X
Bearings, spring seat—service and/or replace .....	X			
Bearings, wheel—service and/or replace .....	X			
Drums, brake—replace .....	X			
Hub assemblies—replace .....	X			
Hub assemblies—repair .....		X		
Hub assemblies—rebuild .....			X	
Hub and drum assemblies—replace .....	X			
Retainers, wheel grease—replace .....	X			
Rod assemblies, torque—service and/or replace .....	X			
Rod assemblies, torque—repair .....		X		
Rod assemblies, torque—rebuild .....			E	X
Seat assemblies, spring—replace .....	X			
Seat assemblies, spring—repair .....		X		
Seat assemblies, spring—rebuild .....			E	X
Shafts, axle—replace .....	X			
Shaft, trunnion—replace .....		X		
Shaft, trunnion—rebuild .....			E	X
Spring assemblies, rear suspension—replace .....	X			
Spring assemblies, rear suspension—repair .....		X		
Spring assemblies, rear suspension—rebuild .....			E	X

NOTE: \*The second echelon is authorized to remove and reinstall items marked by an asterisk. However, when it is necessary to replace an item marked by an asterisk with a new or rebuilt part, subassembly or unit assembly, the assembly marked by an asterisk may be removed from the vehicle by the second echelon *only after authority has been obtained from a higher echelon of maintenance.*

**ORDNANCE MAINTENANCE—POWER TRAIN, SUSPENSION, HULL,  
AND TURRET FOR ARMORED CAR M8 AND UTILITY CAR M20**

	ECHELONS			
	2nd	3rd	4th	5th
<b>BRAKE, PARKING</b>				
Band assembly—service and/or replace . . . . .	X			
Band assembly—repair (reline) . . . . .		X		
Controls and linkage—replace . . . . .	X			
Controls and linkage—repair . . . . .		X		
<b>BRAKES, SERVICE (HYDROVAC)</b>				
Cleaner assembly, air—service and/or replace . . .	X			
Cleaner assembly, air—repair . . . . .		X		
Controls and linkage—service and/or replace . . .	X			
Controls and linkage—repair . . . . .		X		
Cylinder assembly, master—replace . . . . .	X			
Cylinder assembly, master—repair . . . . .		X		
Cylinder assembly, master—rebuild . . . . .			X	
Cylinder assembly (hydrovac)—replace . . . . .	X			
Cylinder assembly (hydrovac)—repair . . . . .		X		
Cylinder assembly (hydrovac)—rebuild . . . . .			E	X
Cylinder assemblies, wheel—replace . . . . .	X			
Cylinder assemblies, wheel—repair . . . . .		X		
Cylinder assemblies, wheel—rebuild . . . . .			X	
Hose, flexible, lines and connections— replace and/or repair . . . . .	X			
Shoe assemblies—service and/or replace . . . . .	X			
Shoe assemblies—repair (reline) . . . . .		X		
<b>CASE, TRANSFER</b>				
*Case assembly, transfer—replace . . . . .	*	X		
Case assembly, transfer—repair . . . . .		X		
Case assembly, transfer—rebuild . . . . .			E	X
Controls and linkage—service and/or replace . . .	X			
Controls and linkage—repair . . . . .		X		
Drums, parking brake—replace . . . . .	X			
<b>COOLING GROUP</b>				
Connections, radiator to engine—replace . . . . .	X			
Radiator assembly—replace . . . . .	X			
Radiator assembly—repair . . . . .		X		

NOTE: \*The second echelon is authorized to remove and reinstall items marked by an asterisk. However, when it is necessary to replace an item marked by an asterisk with a new or rebuilt part, subassembly or unit assembly, the assembly marked by an asterisk may be removed from the vehicle by the second echelon *only after authority has been obtained from a higher echelon of maintenance.*

**INTRODUCTION**

	ECHELONS			
	2nd	3rd	4th	5th
<b>COOLING GROUP (Cont'd)</b>				
Radiator assembly—rebuild .....			E	X
Shroud, fan—replace .....	X			
Shroud, fan—repair .....		X		
System, cooling—service .....	X			
<b>CLUTCH (HYDRAULIC)</b>				
Bearing, pilot—replace .....	X			
Bearing, release—replace .....	X			
Clutch—replace .....		X		
Clutch—repair .....		X		
Clutch—rebuild .....			E	X
Cylinder assembly, hydraulic master—replace ...	X			
Cylinder assembly, hydraulic master—repair ...		X		
Cylinder assembly, hydraulic master—rebuild ...			X	
Cylinder assembly, slave—replace .....	X			
Cylinder assembly, slave—repair .....		X		
Cylinder assembly, slave—rebuild .....			X	
Hose, flexible lines and connections— replace and/or repair .....	X			
Housing, clutch—replace .....		X		
Housing, clutch—rebuild (recondition) .....			E	X
Plate, clutch driven—replace .....	X			
Plate, clutch driven—repair (reline) .....		X		
<b>ELECTRICAL GROUP</b>				
Battery—service, recharge and/or replace .....	X			
Battery—repair .....		X		
Battery—rebuild .....			E	X
Breakers, circuit—replace .....	X			
Cables, battery—replace and/or repair .....	X			
Conduit—replace and/or repair .....		X		
Filters—replace .....	X			
Lamp assemblies—service and/or replace .....	X			
Lamp assemblies—repair .....		X		
Regulator, current and voltage—replace .....	X			
Regulator, current and voltage— service and/or repair .....		X		
Regulator, current and voltage—rebuild .....			X	
Siren—replace .....	X			
Siren—repair .....		X		
Siren—rebuild .....			X	

**ORDNANCE MAINTENANCE—POWER TRAIN, SUSPENSION, HULL,  
AND TURRET FOR ARMORED CAR M8 AND UTILITY CAR M20**

ELECTRICAL GROUP (Cont'd)	ECHELONS			
	2nd	3rd	4th	5th
Solenoids—replace .....	X			
Solenoids—repair .....		X		
Switch assemblies—replace .....	X			
Switch assemblies—repair .....		X		
Switch assemblies—rebuild .....			X	
Wiring—replace and/or repair .....	X			
<b>ENGINE (HERCULES-JXD)</b>				
Bearings, connecting rod (inserts)—replace .....		E	E	X
Bearings, crankshaft main (inserts)—replace .....		E	E	X
Belts, fans and generators—service and/or replace .....	X			
Block, cylinder—rebuild (recondition) .....			E	X
Carburetor assembly—service and/or replace .....	X			
Carburetor assembly—repair .....		X		
Carburetor assembly—rebuild .....			X	
Coil, ignition—replace .....	X			
Condenser, distributor—replace .....	X			
Controls and linkage—service and/or replace .....	X			
Controls and linkage—repair .....		X		
Crankshaft—rebuild (recondition) .....			E	X
Distributor assembly—service and/or replace .....	X			
Distributor assembly—repair .....		X		
Distributor assembly—rebuild .....			X	
*Engine assembly—replace .....	*	X		
Engine assembly—repair .....		X		
Engine assembly—rebuild .....			E	X
Fan and hub assembly—replace .....	X			
Fan and hub assembly—repair .....		X		
Fan and hub assembly—rebuild .....			X	
Filter assembly, oil—service or replace cartridge .....	X			
Filter assembly, oil—replace .....	X			
Filter assembly, oil—repair .....		X		
Flywheel—replace and/or repair .....		X		
Flywheel—rebuild (recondition) .....			E	X
Gaskets, cylinder head and manifold—replace .....	X			

NOTE: \*The second echelon is authorized to remove and reinstall items marked by an asterisk. However, when it is necessary to replace an item marked by an asterisk with a new or rebuilt part, subassembly or unit assembly, the assembly marked by an asterisk may be removed from the vehicle by the second echelon only after authority has been obtained from a higher echelon of maintenance.

**INTRODUCTION**

ENGINE (Cont'd)	ECHELONS			
	2nd	3rd	4th	5th
Gears, timing—replace .....		X		
Generator assembly—replace .....	X			
Generator assembly—repair .....		X		
Generator assembly—rebuild .....			X	
Head, cylinder—replace and/or repair .....		X		
Lines, oil (external)—replace and/or repair .....	X			
Lines, oil (internal)—replace and/or repair .....		X		
Manifolds—replace .....	X			
Manifolds—rebuild .....			X	
Motor assembly, starting—replace .....	X			
Motor assembly, starting—repair .....		X		
Motor assembly, starting—rebuild .....			X	
Pan assembly, oil—service and replace gaskets ..	X			
Pan assembly, oil—replace and/or repair .....		X		
Pistons and rings—replace .....		E	E	X
Plugs, spark—service and/or replace .....	X			
Plugs, spark (two-piece)—repair .....		X		
Points, breaker, distributor—replace .....	X			
Pump assembly, fuel—service and/or replace ...	X			
Pump assembly, fuel—repair .....		X		
Pump assembly, fuel—rebuild .....			X	
Pump assembly, oil—replace and/or repair .....		X		
Pump assembly, oil—rebuild .....			X	
Pump assembly, water—service and/or replace ..	X			
Pump assembly, water—repair .....		X		
Pump assembly, water—rebuild .....			X	
Rods, connecting—replace .....		E	E	X
Strainer, oil—service and/or replace .....	X			
Thermostat—replace .....	X			
Valves—service .....	X			
Ventilator, crankcase—service and/or replace ...	X			
Wiring, ignition—replace .....	X			

**EXHAUST GROUP**

Brackets—replace .....	X
Mufflers and connections—replace .....	X

**EXTINGUISHER, FIRE**

Extinguisher assembly, fire (carbon dioxide, CO <sub>2</sub> )—replace .....	X
---	---



**ORDNANCE MAINTENANCE—POWER TRAIN, SUSPENSION, HULL,  
AND TURRET FOR ARMORED CAR M8 AND UTILITY CAR M20**

	ECHELONS			
	2nd	3rd	4th	5th
<b>EXTINGUISHER, FIRE (Cont'd)</b>				
Extinguisher assembly, fire (carbon dioxide, CO <sub>2</sub> )—repair and/or recharge .....		X		
Extinguisher assembly, fire (carbon dioxide, CO <sub>2</sub> )—rebuild .....			E	X
<b>FUEL GROUP</b>				
Cleaner assembly, air—service and/or replace ...	X			
Cleaner assembly, air—repair .....		X		
Cover, fuel tank—replace .....	X			
Cylinder assembly, throttle master—replace .....	X			
Cylinder assembly, throttle master—repair .....		X		
Cylinder assembly, throttle master—rebuild .....			X	
Cylinder assembly, throttle slave—replace .....	X			
Cylinder assembly, throttle slave—repair .....		X		
Cylinder assembly, throttle slave—rebuild .....			X	
Filter assembly, fuel—service and/or replace ...	X			
Lines and connections—replace and/or repair ...	X			
Pump, priming—replace .....	X			
Pump, priming—repair .....		X		
Pump, priming—rebuild .....			X	
Tank—service and/or replace .....	X			
Tank—repair .....		X		
Reservoir, throttle control—replace .....	X			
Reservoir, throttle control—repair .....		X		
<b>HULL</b>				
Cables, towing—replace .....	X			
Clevis, towing—replace and/or repair .....	X			
Doors and cover plates—replace .....	X			
Doors and cover plates—repair .....		X		
Fenders and brackets—replace .....	X			
Fenders and brackets—repair .....		X		
Hull—repair .....		X		
Hull—rebuild .....			E	X
Periscopes—replace .....	X			
Periscopes—repair .....		X		
Periscopes—rebuild .....			E	X
Pintle assembly—replace .....	X			
Pintle assembly—repair .....		X		
Pintle assembly—rebuild .....				X

**INTRODUCTION**

	<b>ECHELONS</b>			
	2nd	3rd	4th	5th
<b>HULL (Cont'd)</b>				
Protectoscopes—service and/or replace .....	X			
Ring and supports, gun mount—replace .....	X			
Ring and supports, gun mount—repair .....		X		
Seats—replace .....	X			
Seats—repair .....		X		
<b>INSTRUMENTS AND PANEL</b>				
Instruments—replace .....	X			
Instruments—repair .....		X		
Instruments—rebuild .....			X	
Panel and connections—replace .....	X			
Panel and connections—repair .....		X		
<b>MISCELLANEOUS</b>				
Drive assembly, speedometer—replace .....	X			
Drive assembly, speedometer—repair .....		X		
Shackles and bolts—replace .....	X			
Spring assemblies, front suspension—replace .....	X			
Spring assemblies, front suspension—repair .....		X		
Spring assemblies, front suspension—rebuild .....			E	X
<b>SHAFT, PROPELLER</b>				
Block assembly, pillow—replace .....	X			
Block assembly, pillow—repair .....		X		
Block assembly, pillow—rebuild .....			E	X
Shaft assembly, propeller (w/universal joints) —replace .....	X			
Shaft assembly, propeller (w/universal joints) —repair .....		X		
Shaft assembly, propeller (w/universal joints) —rebuild .....			E	X
<b>STEERING GROUP</b>				
Arm, pitman—replace .....	X			
Gear assembly, steering—service .....	X			
Gear assembly, steering—replace and/or repair .....		X		
Gear assembly, steering—rebuild .....			E	X
Link assembly, drag—service and/or replace .....	X			
Link assembly, drag—repair .....		X		
Wheel, steering—replace .....	X			

**TM 9-1743**

**3**

**ORDNANCE MAINTENANCE—POWER TRAIN, SUSPENSION, HULL,  
AND TURRET FOR ARMORED CAR M8 AND UTILITY CAR M20**

	ECHELONS			
	2nd	3rd	4th	5th
<b>TIRES</b>				
Casings and tubes—replace .....	X			
Casings—repair .....			E	X
Tubes, inner—repair .....	X			
<b>TRANSMISSION</b>				
Shafts, control (w/universal joint)—replace ....	X			
Shafts, control (w/universal joint)—repair .....		X		
Shafts, control (w/universal joint)—rebuild ....			E	X
*Transmission assembly—replace .....	*	X		
Transmission assembly—repair .....		X		
Transmission assembly—rebuild .....			E	X
<b>TURRET</b>				
Mechanism, turret traversing—replace .....	X			
Mechanism, turret traversing—repair .....		X		
Mechanism, turret traversing—rebuild .....			E	X
Seats—replace .....	X			
Seats—repair .....		X		
Turret assembly—replace and/or repair .....		X		
Turret assembly—rebuild .....			E	X
<b>VEHICLE ASSEMBLY</b>				
Car, armored, M8 6 x 6 (G136)—service and preventive maintenance .....	X			
Car, armored, M8 6 x 6 (G136)—rebuild (with serviceable unit assemblies) .....			X	E
<b>VEHICLE ASSEMBLY</b>				
Car, armored utility, M20—service and preventive maintenance .....				
Car, armored utility, M20—rebuild (with serviceable unit assemblies) .....			X	E

**NOTE:** \*The second echelon is authorized to remove and reinstall items marked by an asterisk. However, when it is necessary to replace an item marked by an asterisk with a new or rebuilt part, subassembly or unit assembly, the assembly marked by an asterisk may be removed from the vehicle by the second echelon *only after authority has been obtained from a higher echelon of maintenance.*

**NOTE:** Periodically issued bulletins pertaining to reclamation of these vehicles are available to the fourth and fifth echelon maintenance installations. Consult these bulletins before attempting any reclamation procedures.

## CHAPTER 2 TRANSMISSION

### Section I

### DESCRIPTION AND DATA

	Paragraph
Description .....	4
Data .....	5

#### 4. DESCRIPTION.

a. These vehicles are equipped with a four-speed transmission fitted for remote control (fig. 6). The transmission is of the synchronized, selective sliding gear type, and is mounted on the forward end of the engine at the rear of the vehicle.

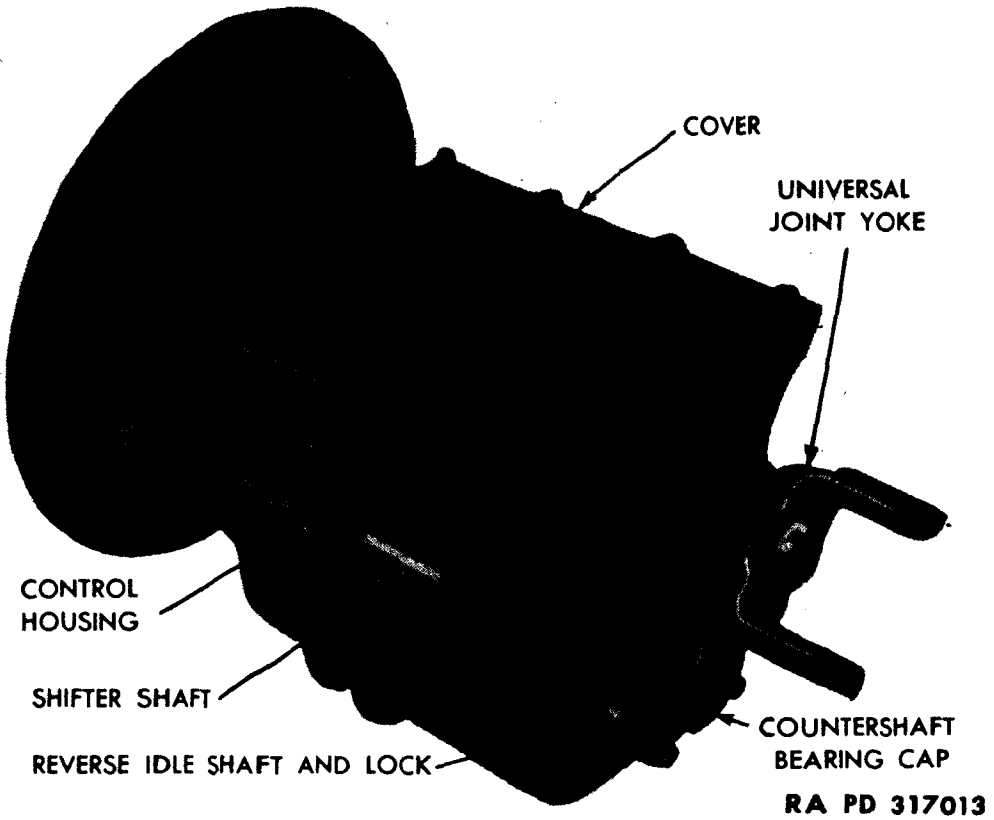
#### 5. DATA.

##### Ratios:

First gear .....	6.499 to 1
Second gear .....	3.543 to 1
Third gear .....	1.752 to 1
Fourth gear .....	1.000 to 1
Reverse .....	6.987 to 1
Make .....	Warner Gear
Model .....	T95-1MF

**THE ARMY LIBRARY**  
WASHINGTON, D.C.

**ORDNANCE MAINTENANCE—POWER TRAIN, SUSPENSION, HULL,  
AND TURRET FOR ARMORED CAR M8 AND UTILITY CAR M20**



**Figure 6—Transmission**

**CHAPTER 2**  
**TRANSMISSION (Cont'd)**

**Section II**

**DISASSEMBLY OF TRANSMISSION**

	<b>Paragraph</b>
Preliminary work .....	6
Disassembly of control housing .....	7
Removal of shift rails .....	8
Removal of gears .....	9
Disassembly of gears .....	10
Removal of oil seals and shifter shaft plug .....	11

**6. PRELIMINARY WORK.**

a. **Remove Universal Joint Yoke.** Remove the cotter pin and castellated nut with the socket wrench (41-W-2626-150) from the main shaft. Slip the yoke and flat washer off the shaft.

b. **Remove Transmission Cover.** Remove the 11 cap screws that hold the transmission cover to the case. Lift off the cover.

c. **Remove Control Housing** (fig. 25). Remove the eight cap screws from the control housing and lift the housing off the case.

d. **Remove Clutch Release Bearing and Spring.** Unhook the clutch release bearing retracting spring from the main drive gear bearing retainer and clutch release bearing hub. Slide the clutch release bearing assembly off the main drive gear bearing retainer.

e. **Remove Clutch Housing.** Remove the four nuts and lock washers that hold the clutch housing to the transmission case. Lift the clutch housing off the transmission case.

f. **Remove Bearing Retainers and Caps.** Remove the four cap screws from the main drive gear bearing retainer and countershaft rear bearing cap and lift them off the case.

g. **Remove Oil Pump.** Remove the three cap screws that hold the oil pump in the transmission and pull out the oil pump.

**7. DISASSEMBLY OF CONTROL HOUSING.**

a. **Remove Shifter Plate from Housing.** Remove the nut and washer from the pivot. Remove the pivot and shifter plate.

b. **Remove Plunger from Housing.** Unscrew the plunger spring seat and lift out the spring and plunger.

ORDNANCE MAINTENANCE—POWER TRAIN, SUSPENSION, HULL,  
AND TURRET FOR ARMORED CAR M8 AND UTILITY CAR M20

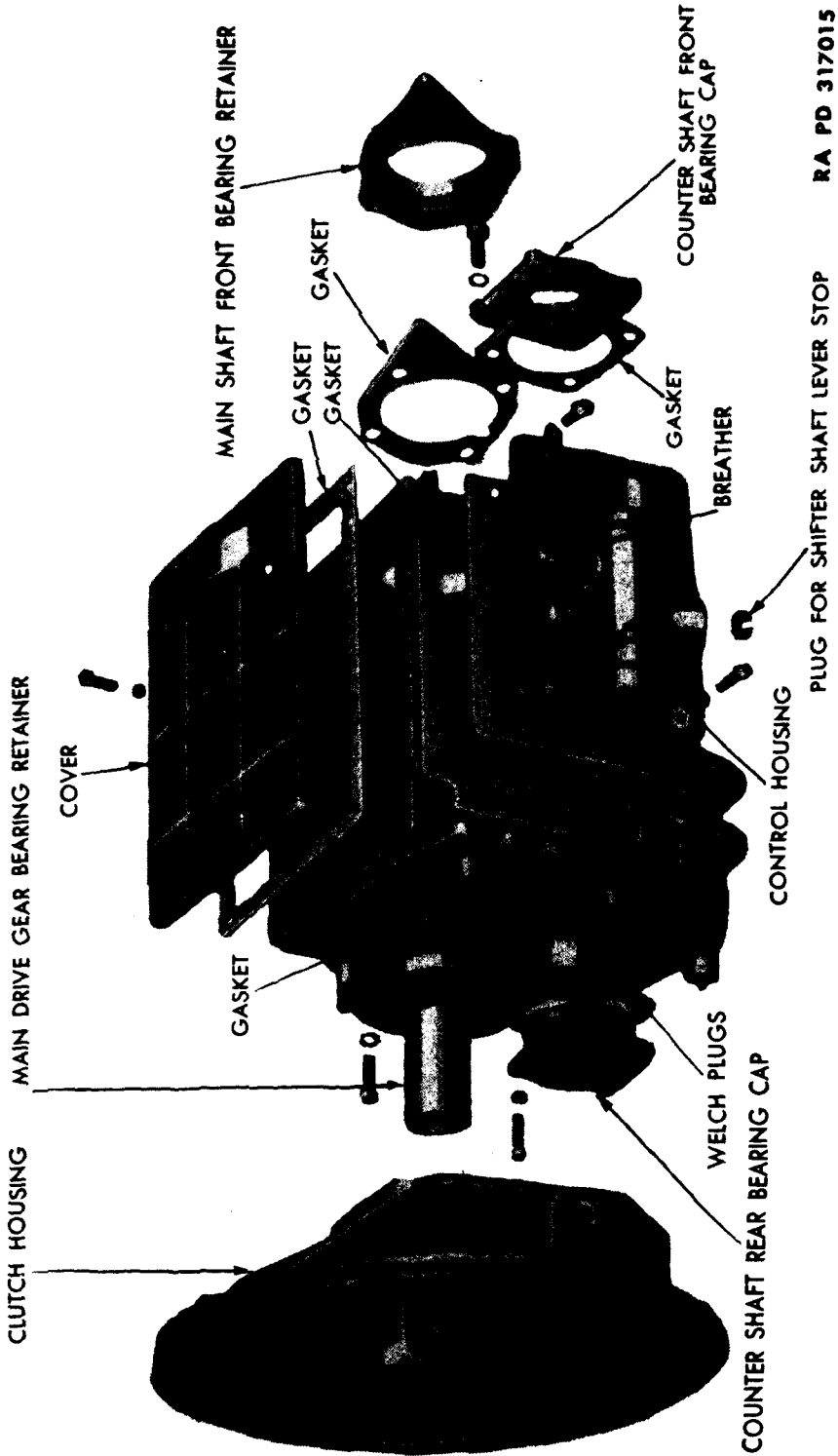


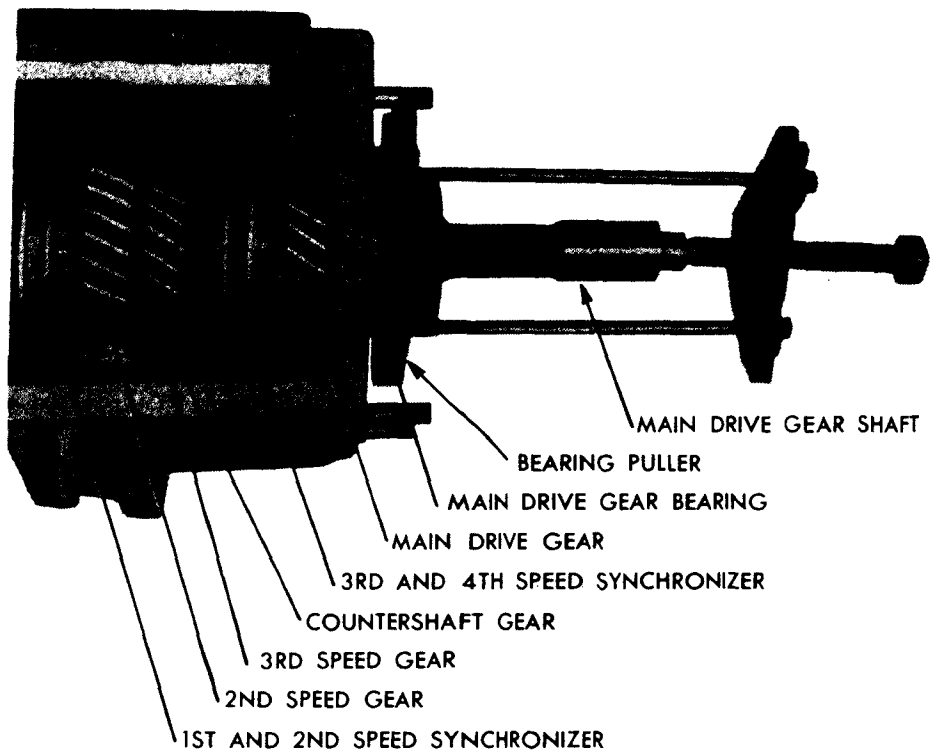
Figure 7 — Transmission Case, Covers and Gaskets, Disassembled

## DISASSEMBLY OF TRANSMISSION

c. **Remove Shifter Shaft and Lever from Housing.** Remove the lock wire from cap screw and remove the screw. Tap the shifter shaft lever toward the rear of the housing. Tap the Woodruff key out of the shifter shaft. Slide the shifter shaft from the housing. It is not necessary to remove the shifter shaft plug unless it is damaged. Drive the shifter shaft plug out of the housing with a driver.

### 8. REMOVAL OF THE SHIFT RAILS.

a. **Remove Guide Rail.** Tap the first and second fork guide rail part way out of the case with a small drift. Pull the guide rail the rest of the way out of the case (fig. 24).



RA PD 28297

**Figure 8—Pulling Main Drive Gear Ball Bearing with Puller 41-P-2900-25**

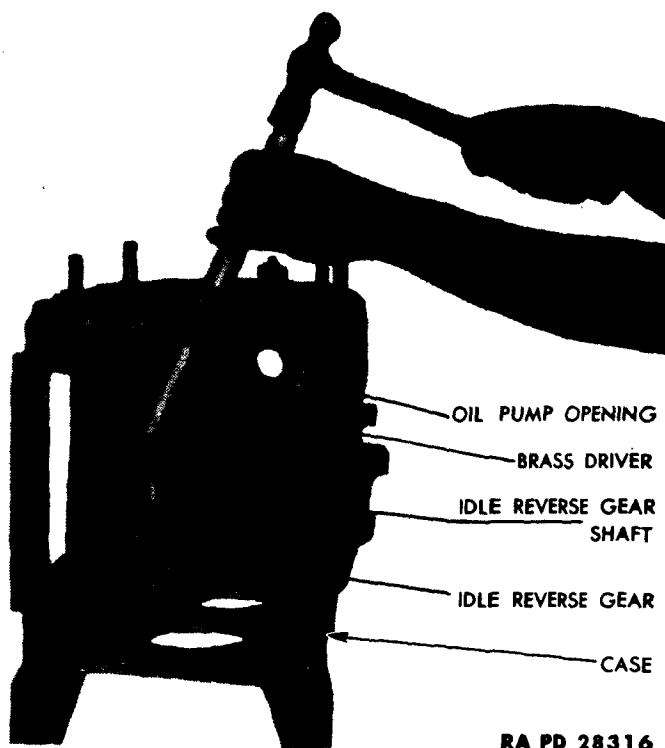
**Remove Shift Rails.** Remove the lock wire and remove all four shift fork lock screws. Slide the first and second gear shifter head to the rear of the transmission. Place a punch in the locating hole in the shift rail and drive the rail part way out of the transmission case. Pull the shift rail the rest of the way out, being careful not to lose the interlock balls and springs. Remove the two remaining shift rails, using the same procedure, except the snap ring must be removed from the third and fourth speed shift rail.



**ORDNANCE MAINTENANCE—POWER TRAIN, SUSPENSION, HULL,  
AND TURRET FOR ARMORED CAR M8 AND UTILITY CAR M20**

**9. REMOVAL OF GEARS.**

a. **Remove Drive Gear.** Slip the cork seal off the main drive gear shaft. Remove the snap rings from the main drive gear shaft and from the drive gear ball bearing. Install bearing puller (41-P-2900-25) on the bearing and pull the bearing out of the case (fig. 8). Tap the oil manifold out of the housing with a brass driver. Remove the front main shaft ball bearing snap ring. Pull the bearing from the housing with bearing puller (41-P-2900-25). Remove the snap ring and washer from the front of the countershaft bearing. Pull the



RA PD 28316

**Figure 9—Driving Idle Reverse Gear Shaft from Case**

countershaft front ball bearing from the housing with bearing puller (41-P-2900-25). Lift the main drive gear from the transmission housing.

b. **Remove Main Drive Gear Shaft.** Slide the shaft and gears to the front of the case as far as possible. Tilt the rear end of the shaft up and lift the shaft and gears from the case as an assembly (fig. 17).

c. **Remove Countershaft Gear from Housing.** Slide the countershaft gear to the front of the case and tilt the front end of the shaft up. Lift the countershaft gear from the case (fig. 16).

## **DISASSEMBLY OF TRANSMISSION**

**d. Remove Idle Reverse Gear.** Remove the cap screw and the idle reverse gear shaft lock from the case. Drive the idle reverse gear shaft from the case with a brass driver (fig. 9). Lift the gear out of the case.

### **10. DISASSEMBLY OF GEARS.**

**a. Disassemble Main Drive Gear.** Pry the snap ring out of the drive gear and remove the rollers.

**b. Disassemble Main Shaft.** Slide the blocking ring off the main shaft. Remove the snap ring and slide the third and fourth speed synchronizer off the shaft. Slide the third speed gear off the shaft. Slide the reverse gear, first gear, first and second speed synchronizer, thrust washer and second speed gear off the shaft.

**c. Disassemble Idle Reverse Gear.** Remove the snap ring from the idle reverse gear shaft sleeve. Slip the sleeve out of the idle reverse gear and remove the rollers and spacers.

### **11. REMOVAL OF OIL SEALS AND SHIFTER SHAFT PLUG.**

**a. Oil Seals.** Pry the oil seal from the front main shaft bearing retainer and from the shifter shaft housing.

**b. Shifter Shaft Plug.** It is not necessary to remove the shifter shaft plug unless damaged. Drive it from the housing with a long drift.

**ORDNANCE MAINTENANCE—POWER TRAIN, SUSPENSION, HULL,  
AND TURRET FOR ARMORED CAR M8 AND UTILITY CAR M20**

**CHAPTER 2**

**TRANSMISSION (Cont'd)**

**Section III**

**TRANSMISSION CLEANING, INSPECTION AND REPAIR**

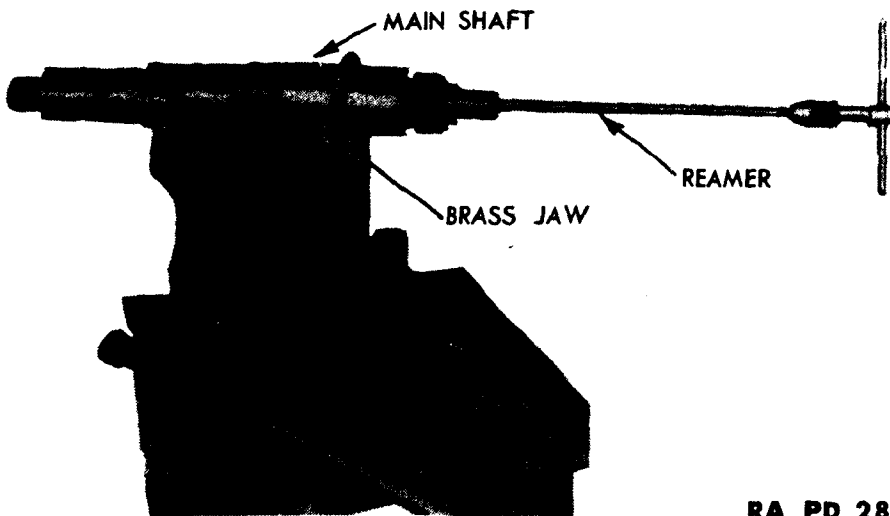
	<b>Paragraph</b>
Cleaning .....	12
Inspection and repair .....	13

**12. CLEANING.**

a. Wash all parts thoroughly in dry-cleaning solvent. Rotate the bearings while immersed in the dry-cleaning solvent until all trace of old lubricant has been removed. Oil the bearings immediately after cleaning to prevent corrosion of the highly polished surfaces.

**13. INSPECTION AND REPAIR.**

a. Transmission Case Assembly (fig. 7). Inspect the case, cover and the clutch and shifter shaft housings for cracks or damage of any kind. Cracked or damaged units must be replaced.



**RA PD 28295**

**Figure 10—Cleaning Oil Passage of Main Shaft with Reamer 41-R-848**

b. Main Drive Gear Assembly (fig. 14). Replace main drive gear if excessively worn or if it has broken teeth, a twisted shaft, or pitted, discolored bearing surfaces due to overheating. Small nicks can be honed and then polished with a fine stone. Measure the inside diam-

**TRANSMISSION CLEANING, INSPECTION AND REPAIR**

eter of the gear. If more than 1.299 inches, the main drive gear must be replaced.

c. **Main Shaft** (fig. 14). Replace main shaft if excessively worn or if it has pitted, discolored bearing surfaces due to overheating. Measure the outside diameter of the four bearing surfaces. Starting at the threaded end of the shaft, the size of the four bearing surfaces must be no smaller than 1.9975 inches, 2.2475 inches, 1.8725 inches and 0.796 inch, or the shaft must be replaced. Clean the oil passage of the main shaft with reamer (41-R-848) (fig. 10). Clean out the oil holes on the gear bearing surfaces thoroughly.

d. **First, Second, and Third Gears** (fig. 15). Replace gears if excessively worn, or if they have broken teeth, chipped teeth, scored or worn bearings. Gears with small nicks can be honed and then polished with a fine stone. Measure the inside diameter of the bearings. If more than 1.876 inches for the third gear, 2.501 inches for the second gear, or 2.001 inches for the first gear, the gear must be replaced.

e. **Countershaft Gear** (fig. 14). Replace excessively worn gears, those with broken or chipped teeth, and gears with pitted or discolored bearing surfaces due to overheating. Measure the front and rear bearing surfaces of the countershaft gear. If less than 1.7310 inches on the rear or 1.3775 inches on the front, the gear must be replaced. Small nicks can be honed and then polished with a fine stone.

f. **Reverse Gear** (fig. 15). A reverse gear, with excessively worn, broken, or chipped teeth, or splines, must be replaced. A gear with small nicks can be honed and then polished with a stone.

g. **Idle Reverse Gear** (fig. 14). Replace gears with excessively worn or broken teeth, or if they have a pitted or discolored bearing surface. Small nicks can be honed and polished with a fine stone. Measure the inside diameter of the gear and the outside diameter of the idle shaft sleeve. If the reading is larger than 1.799 inches for the gear and 1.4202 inches for the sleeve, the gear or shaft must be replaced.

h. **Synchronizers** (fig. 14). Blocking rings with worn, broken, or nicked teeth must be discarded. Hubs with excessively worn splines must be replaced. Sleeves with broken, nicked, or worn teeth or excessively worn splines must be replaced.

i. **Needle Bearing Rollers** (fig. 14). Needle bearing rollers with flat spots, pitted or discolored surfaces, must be replaced. Measure the diameter of each roller. If less than 0.2495 inch (main drive gear

**ORDNANCE MAINTENANCE—POWER TRAIN, SUSPENSION, HULL,  
AND TURRET FOR ARMORED CAR M8 AND UTILITY CAR M20**

bearing recess) and 0.186 inch for the idle reverse gear, the rollers must be replaced.

**j. Ball Bearings** (fig. 14). Ball bearings with loose or discolored balls, or pitted or cracked races, must be replaced.

**k. Thrust Washer** (fig. 14). The second speed thrust washer must be replaced, if cracked or excessively worn.

## CHAPTER 2 TRANSMISSION (Cont'd)

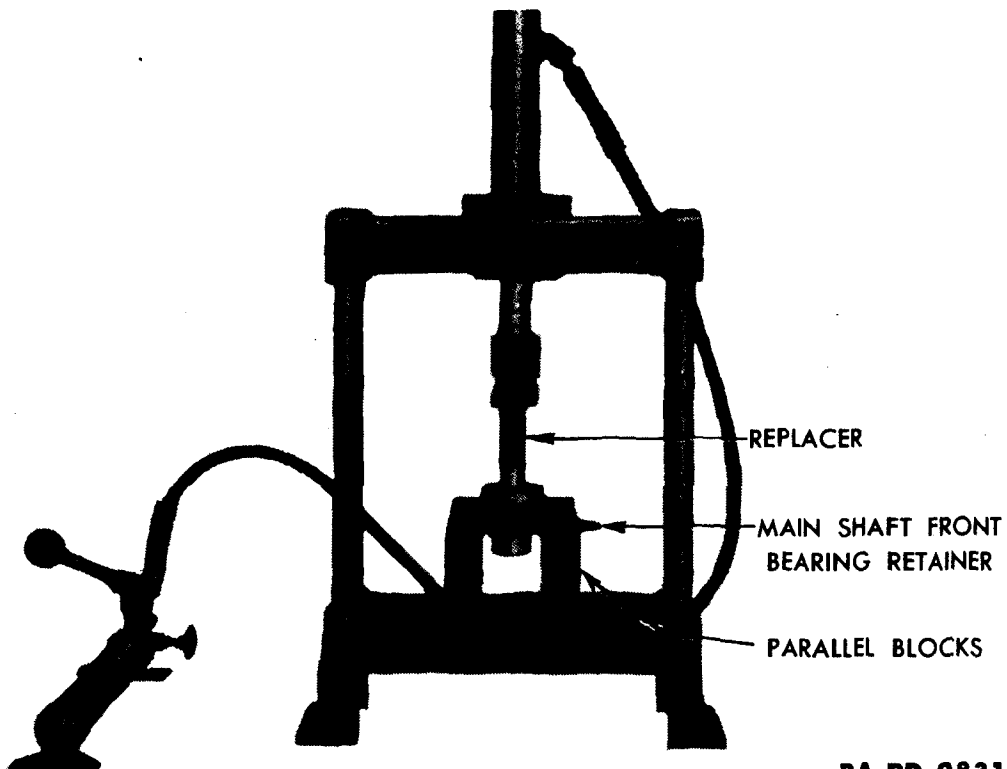
### Section IV

## ASSEMBLY OF TRANSMISSION

	Paragraph
Installation of oil seals and shifter shaft plug .....	14
Assembly of gears .....	15
Installation of gears in case .....	16
Installation of shift rails .....	17
Assembly and installation of control housing .....	18

### 14. INSTALLATION OF OIL SEALS AND SHIFTER SHAFT PLUG.

a. **Install Oil Seals.** Place the front main shaft bearing retainer in a press. With replacer (41-R-2397-95) press the oil seal in the retainer (fig. 11). Place the shifter shaft housing in a vise and drive the oil seal into the housing with replacer (41-R-2396-27) (fig. 12).



RA PD 28311

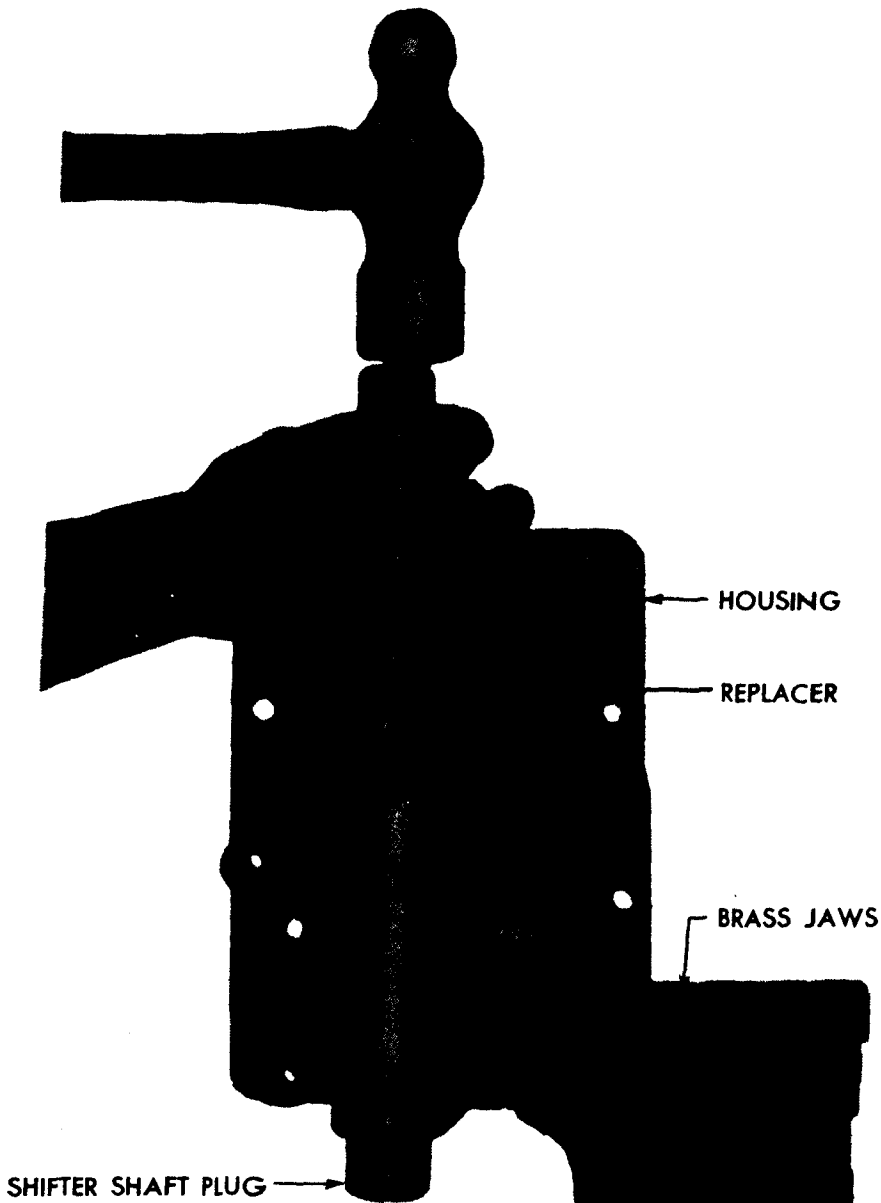
**Figure 11—Pressing Oil Seal in Main Shaft Front Bearing Retainer**

b. **Install Shifter Shaft Plug.** Place the shifter shaft housing in a vise and drive the shifter shaft plug into the housing with replacer (41-R-2395-150) (fig. 13).

**ORDNANCE MAINTENANCE—POWER TRAIN, SUSPENSION, HULL,  
AND TURRET FOR ARMORED CAR M8 AND UTILITY CAR M20**

**15. ASSEMBLY OF GEARS.**

a. Assemble Idle Reverse Gear (fig. 14). Slide the idle reverse gear shaft sleeve into the front end of the idle reverse gear. Drop 27 rollers into the opposite end of the idle gear. Drop the spacer and the



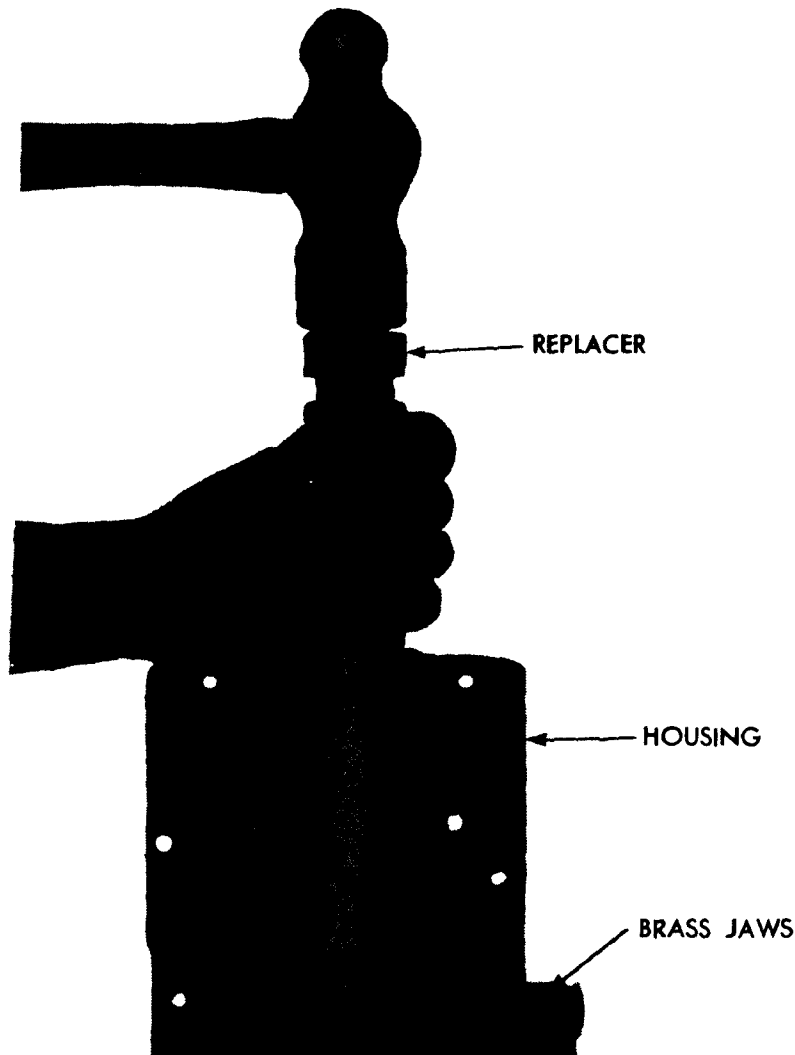
RA PD 28354

**Figure 12—Driving Oil Seal in Shifter Shaft Housing with  
Replacer 41-R-2396-27**

other 27 rollers into the idle reverse gear. The clearance between the rollers and the gear must not exceed 0.0038 inch. Install the idle reverse gear thrust washer and snap ring on the sleeve.

**ASSEMBLY OF TRANSMISSION**

b. **Assemble Main Drive Gear** (fig. 14). Install the 13 rollers in the main drive gear. Install the main shaft pilot bearing snap ring into the drive gear. The clearance must not exceed 0.0035 inch between the main shaft and the brass bushing in the drive gear. This bushing acts as an oil seal in distributing oil to the main shaft. The clearance between the main drive gear shaft and drive gear must not exceed 0.0035 inch.



RA PD 28355

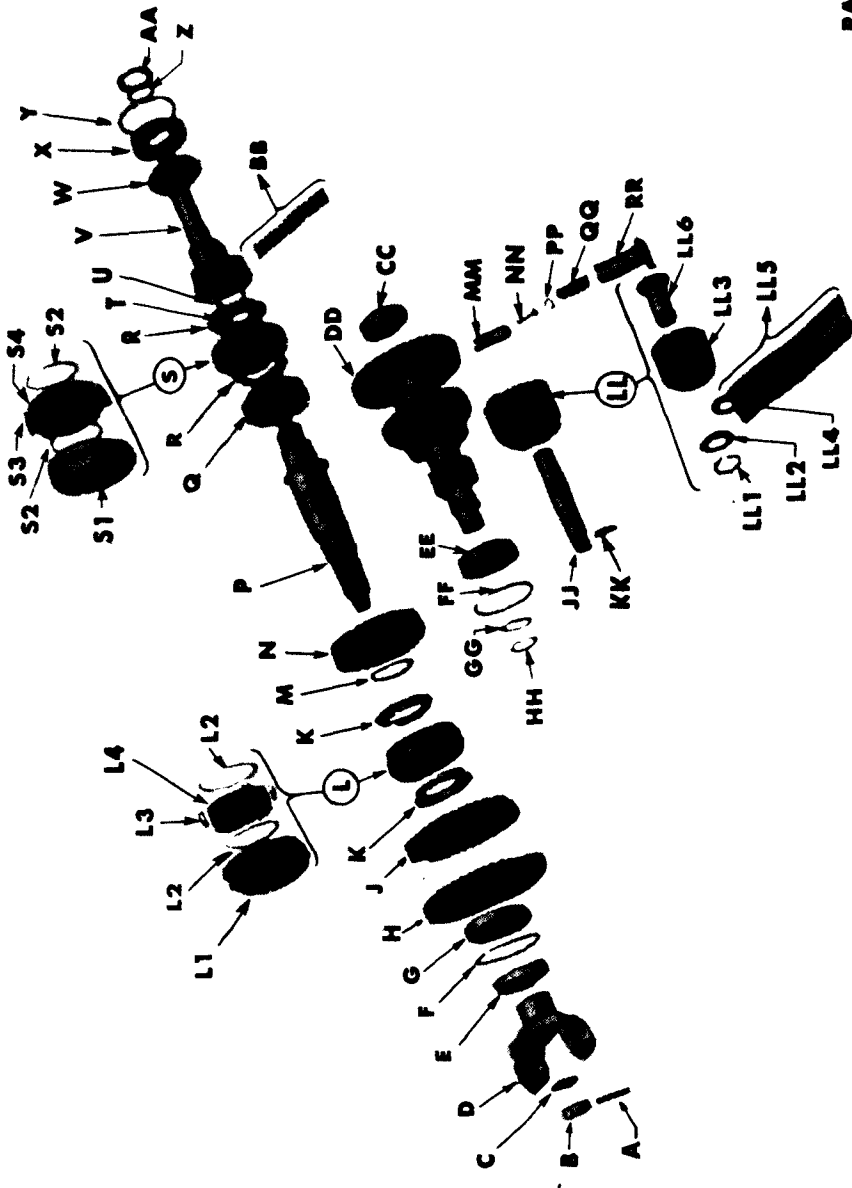
**Figure 13—Driving Shifter Shaft Plug in Housing with Replacer 41-R-2395-150**

c. **Assemble Synchronizers** (fig. 14). Install a synchronizer spring on each side of the synchronizer hub. Place the three plates in the hub, and slide the hub assembly into the sleeve.

d. **Assemble the Third and Fourth Speed Synchronizer on Main Drive Gear Shaft** (fig. 14). Slip the third gear onto the shaft with the gear teeth that engage the synchronizer toward the rear of



ORDNANCE MAINTENANCE—POWER TRAIN, SUSPENSION, HULL,  
AND TURRET FOR ARMORED CAR M8 AND UTILITY CAR M20



RA PD 28299

Figure 14—Transmission Assembly, Gears, Bearings and Shafts, Disassembled

**ASSEMBLY OF TRANSMISSION**

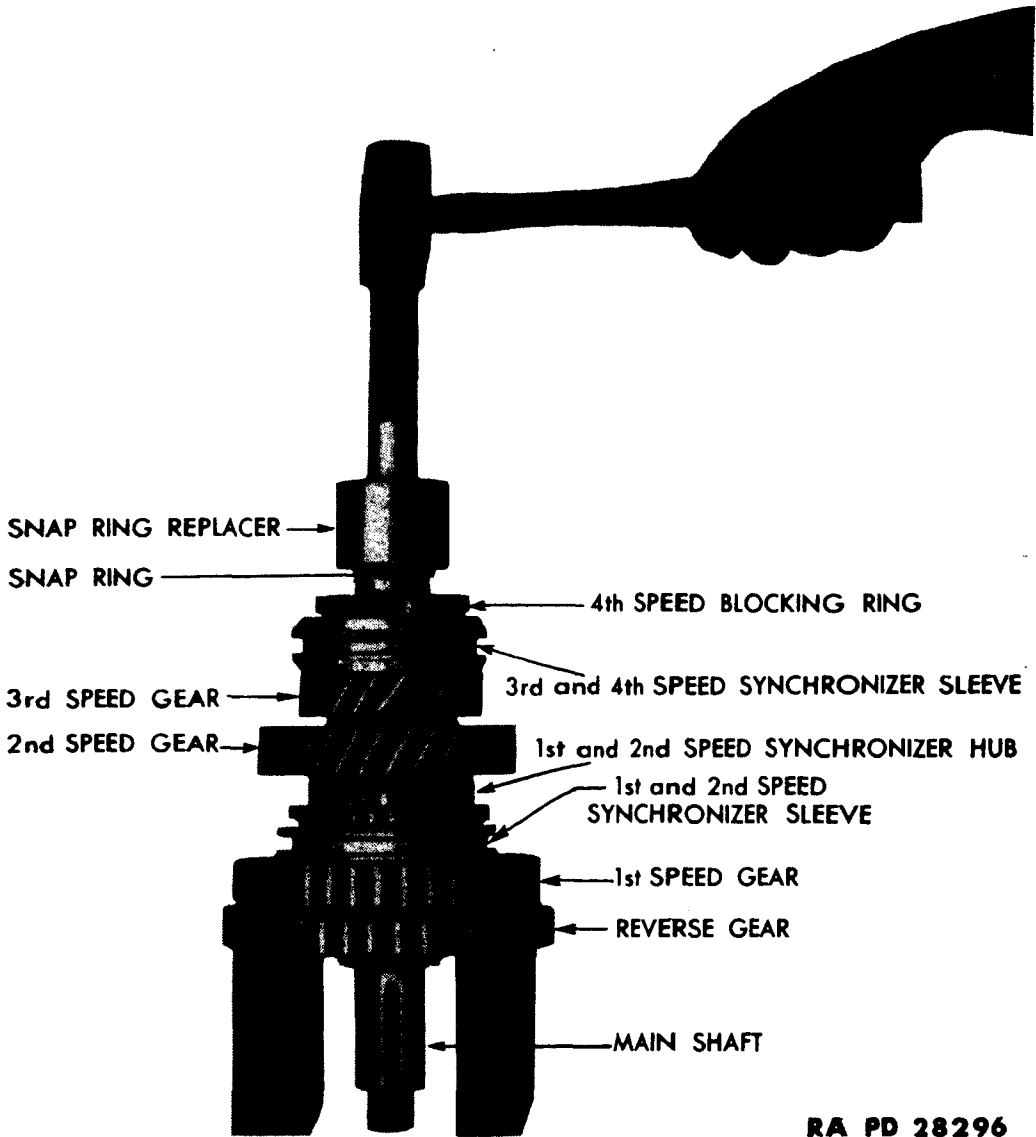
- A—COTTER PIN
- B—CASTELLATED NUT
- C—FLAT WASHER
- D—YOKE
- E—TRANSMISSION MAIN SHAFT OIL SEAL (FRONT)
- F—MAIN SHAFT SNAP RING (FRONT BEARING)
- G—MAIN SHAFT BALL BEARING (FRONT)
- H—MAIN SHAFT REVERSE GEAR
- J—MAIN SHAFT LOW SPEED OR 1ST GEAR
- K—BLOCKING RING 1ST OR 2ND SPEED SYNCHRONIZER
- L—SYNCHRONIZER ASSEMBLY, 1ST AND 2ND SPEED
- L1—SLEEVE
- L2—SPRING
- L3—PLATE
- L4—HUB
- M—THRUST WASHER 2ND SPEED GEAR
- N—MAIN SHAFT 2ND SPEED GEAR
- P—TRANSMISSION MAIN SHAFT
- Q—MAIN SHAFT 3RD SPEED GEAR
- R—BLOCKING RING 3RD AND 4TH SPEED SYNCHRONIZER
- S—SYNCHRONIZER ASSEMBLY 3RD AND 4TH SPEED
- S1—SLEEVE
- S2—SPRING
- S3—PLATE
- S4—HUB
- T—MAIN SHAFT PILOT BEARING SNAP RING
- U—MAIN DRIVE GEAR NEEDLE ROLLER BEARING SNAP RING
- V—MAIN DRIVE GEAR ASSEMBLY
- W—OIL MANIFOLD
- X—MAIN DRIVE GEAR BALL BEARING
- Y—MAIN DRIVE GEAR BALL BEARING SNAP RING
- Z—MAIN DRIVE GEAR SNAP RING
- AA—TRANSMISSION REAR BEARING OIL SEAL
- BB—MAIN DRIVE GEAR BEARING NEEDLE ROLLERS
- CC—COUNTERSHAFT ROLLER BEARING
- DD—COUNTERSHAFT GEAR
- EE—COUNTERSHAFT BALL BEARING
- FF—COUNTERSHAFT BALL BEARING SNAP RING
- GG—COUNTERSHAFT BALL BEARING WASHER
- HH—COUNTERSHAFT BALL BEARING SNAP RING
- JJ—REVERSE IDLE GEAR SHAFT
- KK—REVERSE IDLE GEAR SHAFT LOCK
- LL—REVERSE IDLE GEAR WITH BEARING ASSEMBLED
- LL1—REVERSE IDLE GEAR SNAP RING
- LL2—REVERSE IDLE GEAR THRUST WASHER
- LL3—REVERSE IDLE GEAR WITHOUT BEARING
- LL4—REVERSE IDLE GEAR NEEDLE ROLLER SPACER
- LL5—REVERSE IDLE GEAR NEEDLE ROLLERS
- LL6—IDLE GEAR SHAFT SLEEVE
- MM—OIL PUMP PISTON
- NN—OIL PUMP VALVE AND GUIDE
- PP—SNAP RING
- QQ—OIL PUMP PISTON SPRING
- RR—OIL PUMP HOUSING

RA PD 28299-B

**Legend for Figure 14—Transmission Assembly, Gears, Bearings and Shafts, Disassembled**

**ORDNANCE MAINTENANCE—POWER TRAIN, SUSPENSION, HULL, AND TURRET FOR ARMORED CAR M8 AND UTILITY CAR M20**

the shaft. The clearance between the shaft and the gear must not exceed 0.0035 inch. Slide the third and fourth speed synchronizer blocking ring onto the third gear. Slide the third and fourth speed synchronizer assembly on the shaft with the small end of the hub toward the rear of the case. Turn synchronizer ring until slots in



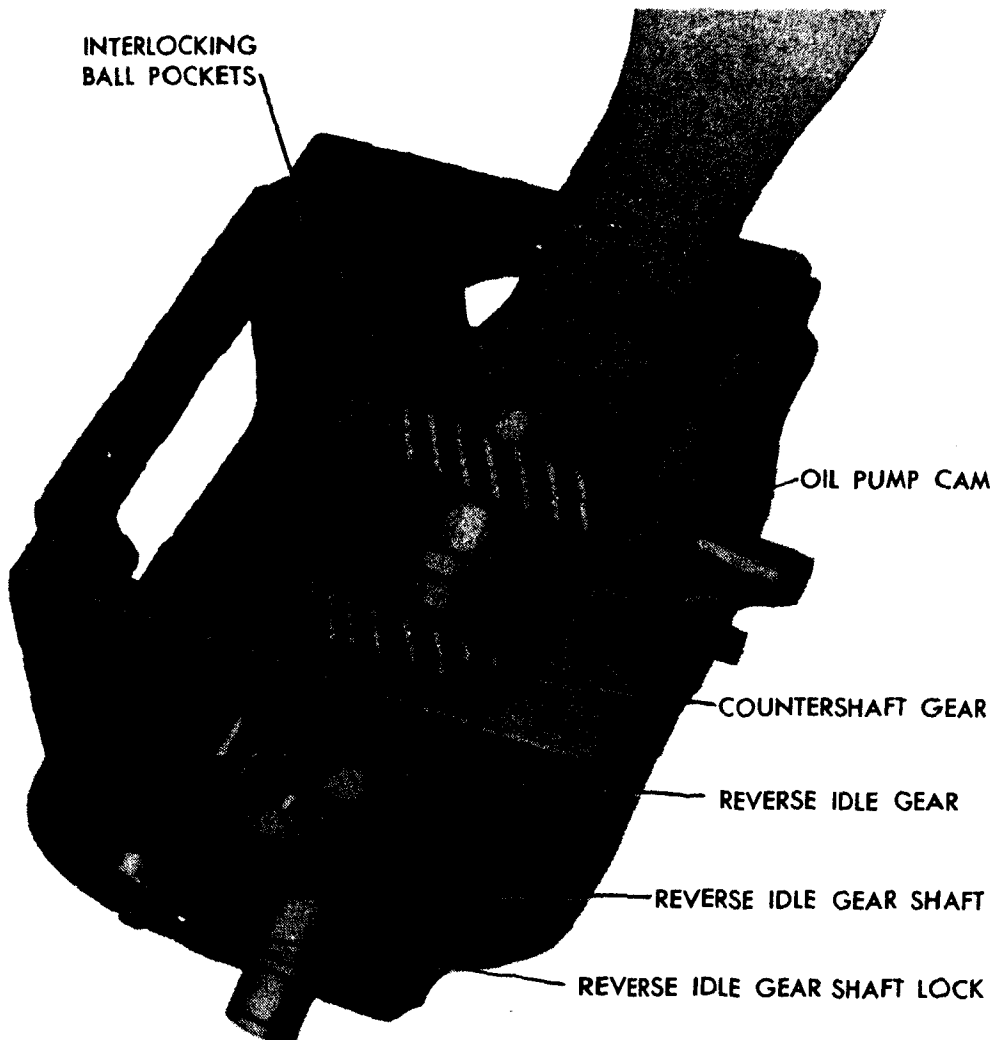
**Figure 15—Installing Third and Fourth Speed Synchronizer Snap Ring on Main Shaft with Replacer 41-R-2396-29**

ring engage blocker keys. Install the snap ring on the shaft with snap ring replacer (41-R-2396-29) (fig. 15). No backlash must exist between the synchronizer hub and the shaft.

e. **Assemble Second Gear on Main Shaft.** Slide the second gear on the front end of the shaft with the internal gear facing to the front

**ASSEMBLY OF TRANSMISSION**

of the shaft. The clearance between the shaft and the gear must not exceed 0.0035 inch. Slide the second speed thrust washer on the shaft. Slide it down the shaft until it touches the second gear. Turn the thrust washer until the splines in the thrust washer line up with the splines of the shaft. The clearance between the second gear and shoulder on the main shaft must not exceed 0.015 inch.



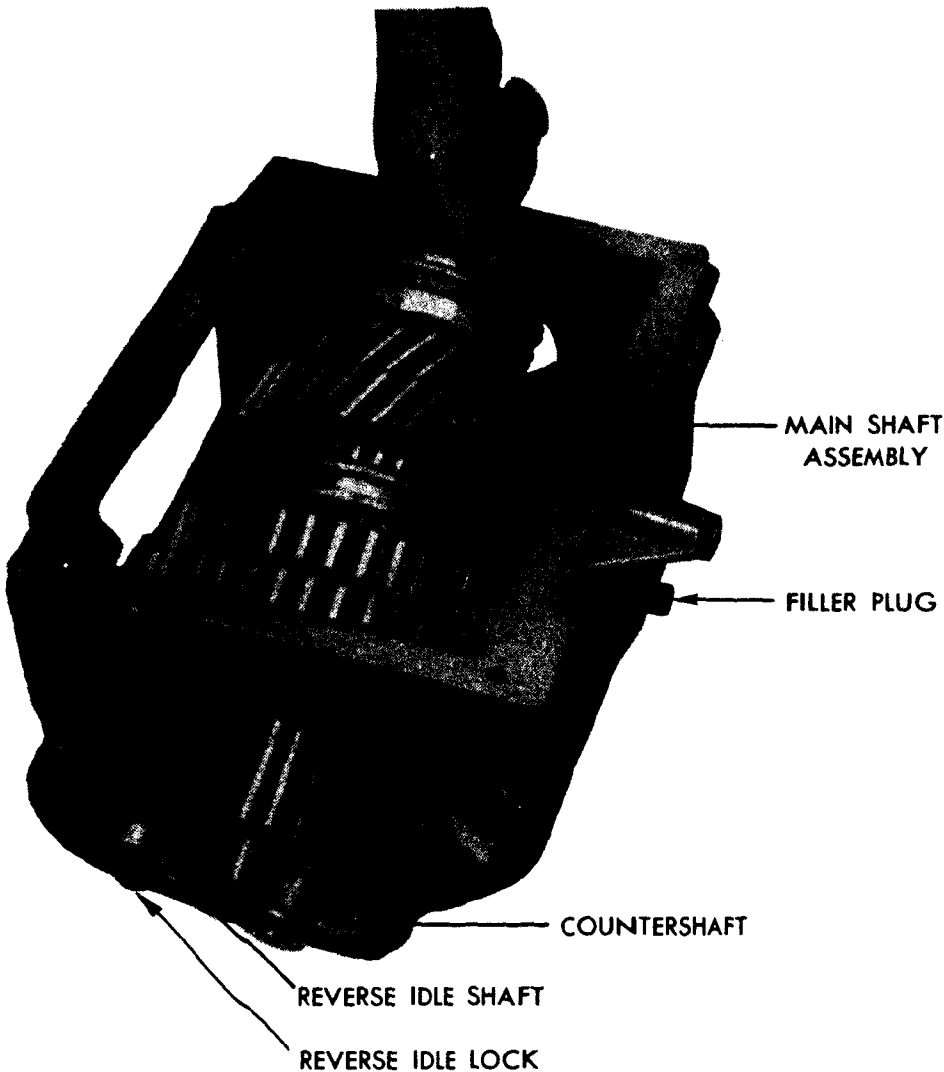
RA PD 28313

**Figure 16—Lowering Countershaft Gear into Case**

f. Assemble First and Second Speed Synchronizer on Main Shaft (fig. 15). Slide blocking ring onto the second gear with the small end of taper to the rear of the shaft, turning to engage slots in ring on blocker keys. Slide the first and second speed synchronizer assembly onto the shaft, making sure the splines on the synchronizer fit into the second speed thrust washer. Slide the other blocking ring

**ORDNANCE MAINTENANCE—POWER TRAIN, SUSPENSION, HULL,  
AND TURRET FOR ARMORED CAR M8 AND UTILITY CAR M20**

into the synchronizer with the small end of the taper to the front of the shaft, making sure that the synchronizer ring engages the keys in the synchronizer.



RA PD 28317

**Figure 17—Lowering Main Shaft Assembly into Case**

g. Assemble First Gear on Shaft (fig. 15). Slide the first gear on the shaft with the internal gear facing toward the rear of the shaft. The clearance between the gear and shaft must not exceed 0.0035 inch.

h. Assemble Reverse Gear on Shaft (fig. 15). Slide the reverse gear onto the shaft with the rounded end of teeth facing toward the

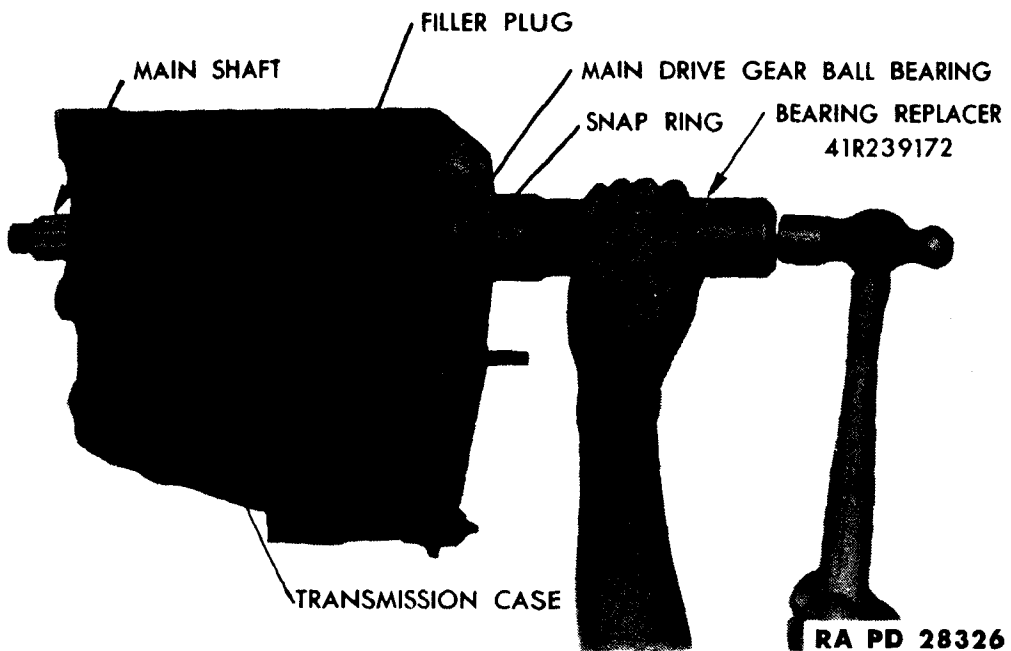
## ASSEMBLY OF TRANSMISSION

rear of the shaft. No backlash must exist between reverse gear and main shaft.

### 16. INSTALLATION OF GEARS IN CASE.

a. **Install Idle Gear.** Place the idle gear in the case with the shifter fork end toward the rear of the case. Tap the idle gear shaft into the case and through the idle gear shaft sleeve. Place the idle gear shaft lock in the slot of the idle reverse gear shaft and install the cap screw in the lock (fig. 16).

b. **Install Countershaft Gear.** Lower the countershaft gear in the case, with the small end of the shaft extending through the front

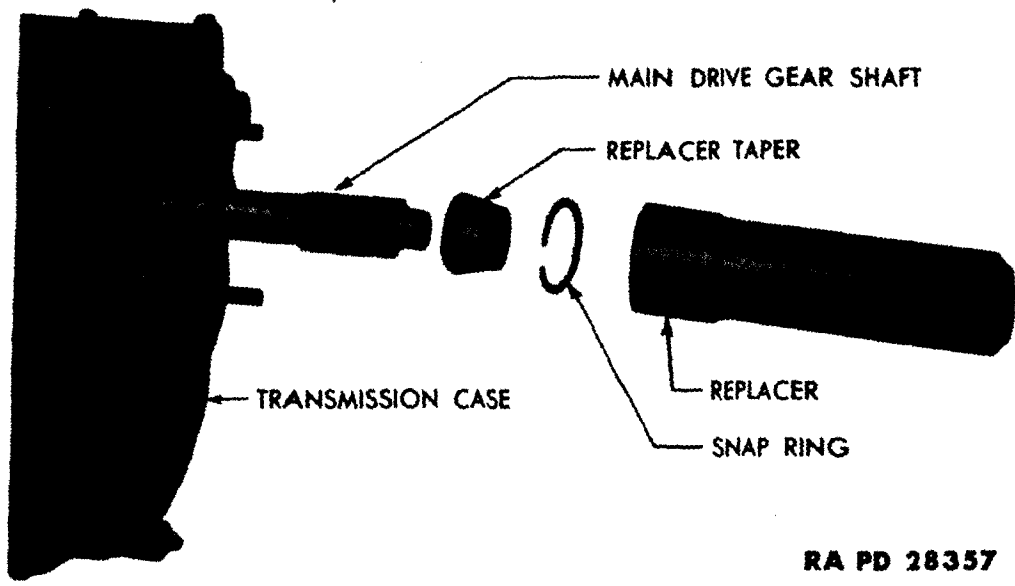


**Figure 18—Driving Main Drive Gear Bearing into Case with Bearing Replacer 41-R-2391-72**

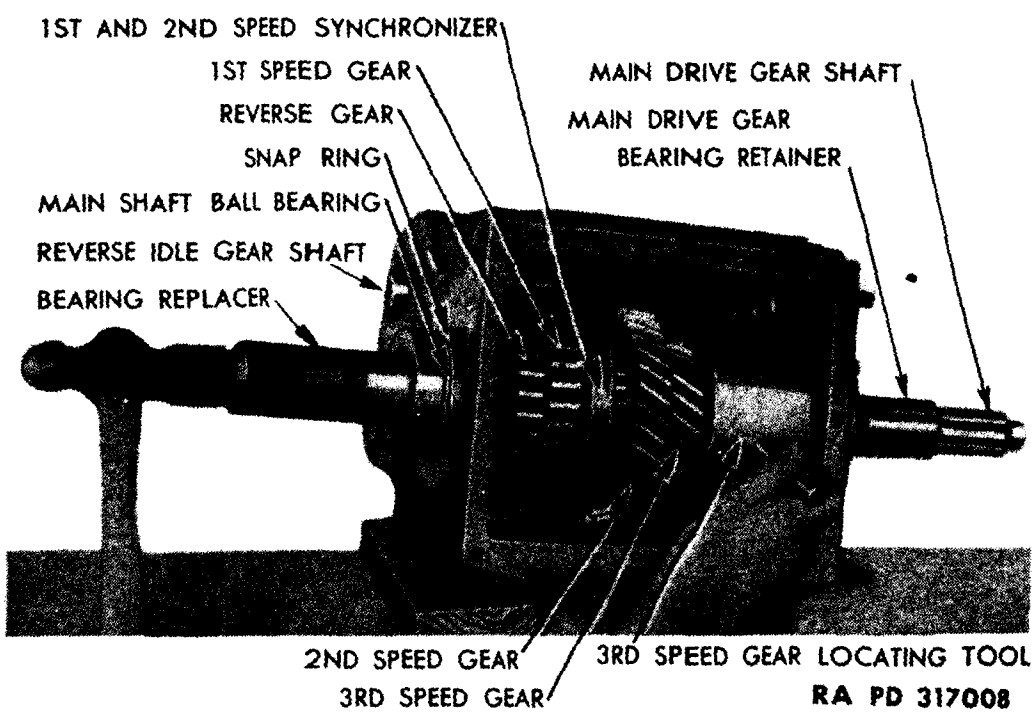
c. **Install Main Shaft Assembly.** Lower the main shaft assembly into the case on an angle with the reverse gear end of the main shaft extending through the opening in the front of the case (fig. 17).

d. **Install Bearing and Main Drive Gear.** Install the third and fourth speed blocking ring in the synchronizer, turning to engage slots in ring on blocker keys. Install the main drive gear into the case and onto the main shaft. Slide the oil manifold (W, fig. 14) onto the main drive gear, and tap it into the case with a brass drift. Install the main drive gear bearing snap ring on the main drive gear bearing.

**ORDNANCE MAINTENANCE—POWER TRAIN, SUSPENSION, HULL,  
AND TURRET FOR ARMORED CAR M8 AND UTILITY CAR M20**



**Figure 19—Driving Main Drive Gear Snap Ring on Main Shaft with  
Snap Ring Replacer 41-R-2396-29**

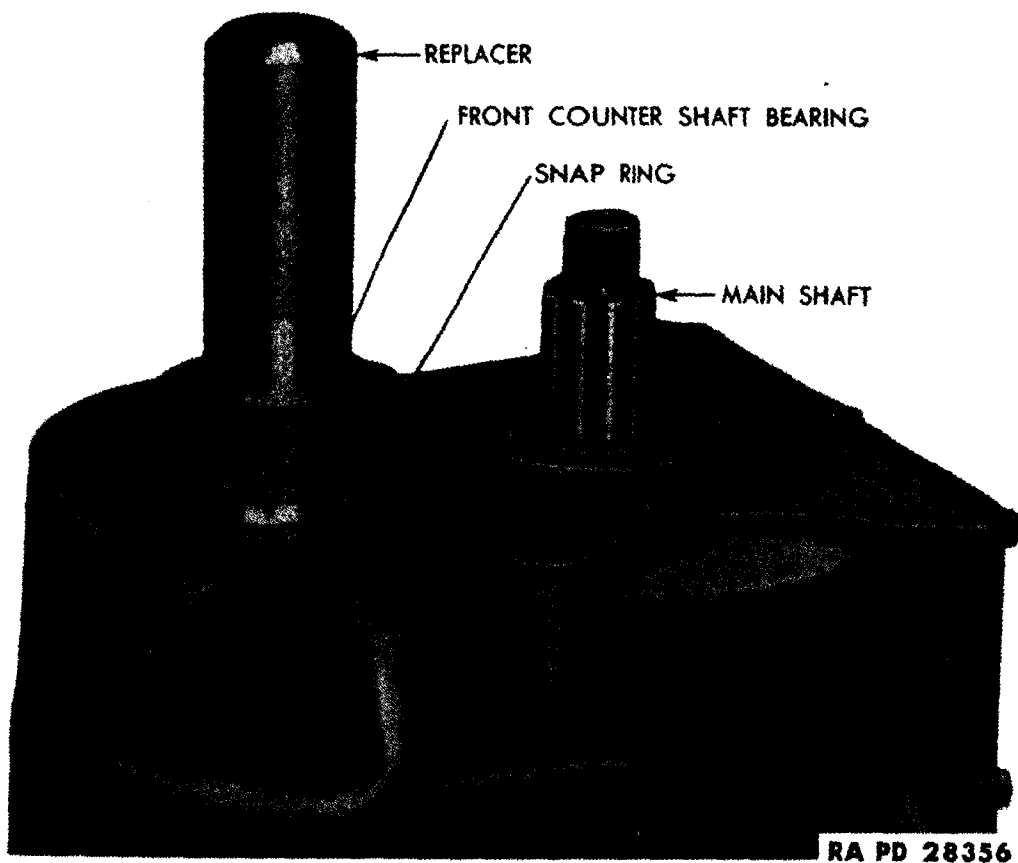


**Figure 20—Driving Front Bearing into Case with Bearing Replacer  
41-R-2397-72 and Third Speed Gear Locating Tool 41-T-3261-450**

### ASSEMBLY OF TRANSMISSION

Drive the bearing onto the shaft and into the case with the bearing replacer (41-R-2391-72) (fig. 18). Install the main drive gear snap ring on the shaft with the snap ring replacer (41-R-2396-29) (fig. 19). Install the cork washer on the main drive gear shaft. Install the main drive gear bearing retainer on the main drive gear and case.

e. **Install Main Shaft Bearing.** Until the time when the main shaft bearing is installed, take care that the second speed synchronizer does not slide forward enough to disengage the slots in the



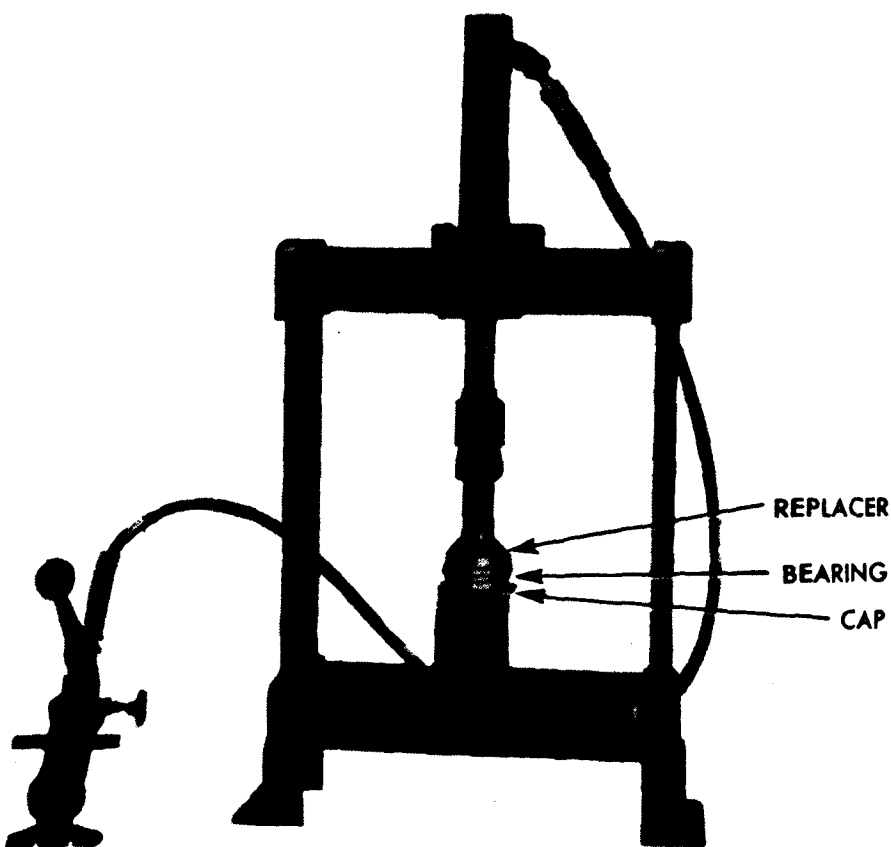
**Figure 21—Driving Countershaft Front Bearing into Case with Bearing Replacer 41-R-2397-72**

second speed thrust washer. If the thrust washer should turn, the slots would not line up and the synchronizer could not be assembled in its proper position. As soon as the bearing is installed, insert the front retainer to hold the parts in position. Install the snap ring on the main shaft bearing. Drive the bearing into the case and on the shaft with bearing replacer (41-R-2397-72) (fig. 20), and third speed gear locating assembly (41-T-2361-450). Install the main shaft bearing retainer on the case.



**ORDNANCE MAINTENANCE—POWER TRAIN, SUSPENSION, HULL,  
AND TURRET FOR ARMORED CAR M8 AND UTILITY CAR M20**

f. **Install Front and Rear Countershaft Bearings.** Install the snap ring on the front countershaft bearing. With the bearing replacer (41-R-2397-72), drive the front countershaft bearing on the shaft and into the case (fig. 21). Install the front countershaft bearing washer and snap ring on the front end of the countershaft gear. Press the countershaft roller bearing into the bearing cap with replacer (41-R-2391-49) (fig. 22). Install the countershaft roller bearing and countershaft bearing cap assembly in the case. Tap the



RA PD 28312

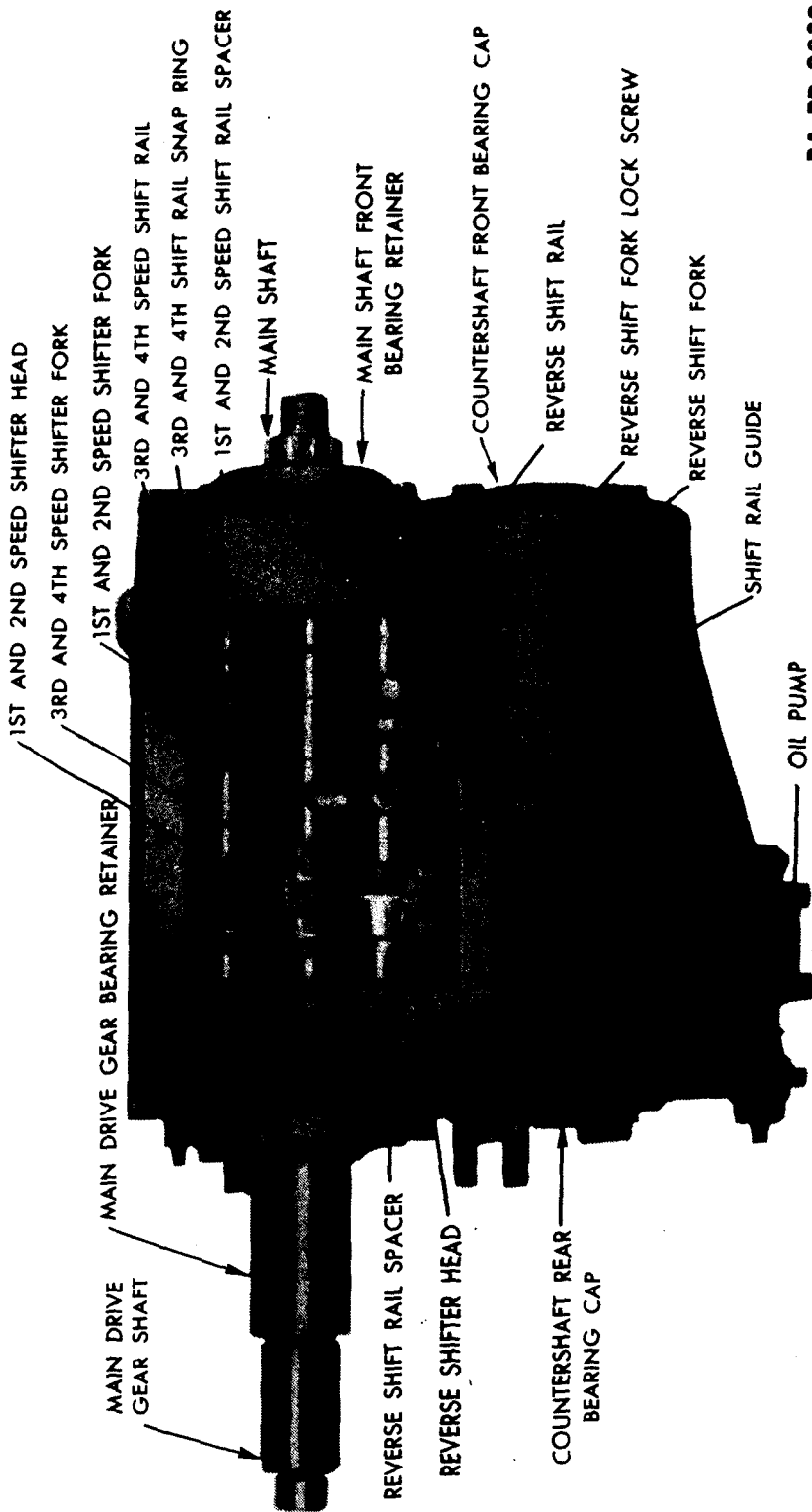
**Figure 22—Pressing Countershaft Rear Bearing in Cap with  
Bearing Replacer 41-R-2391-49**

countershaft rear bearing cap assembly on the countershaft and into the case with a brass hammer, and install the four cap screws. Slide the oil pump assembly in the case, and install the three cap screws.

**17. INSTALLATION OF SHIFT RAILS.**

a. **Install Shift Rails** (fig. 23). Drop an interlock spring and interlock ball in the lower pocket of the case. Press down on the ball, and slide the reverse shift rail part way in the case. Slide the

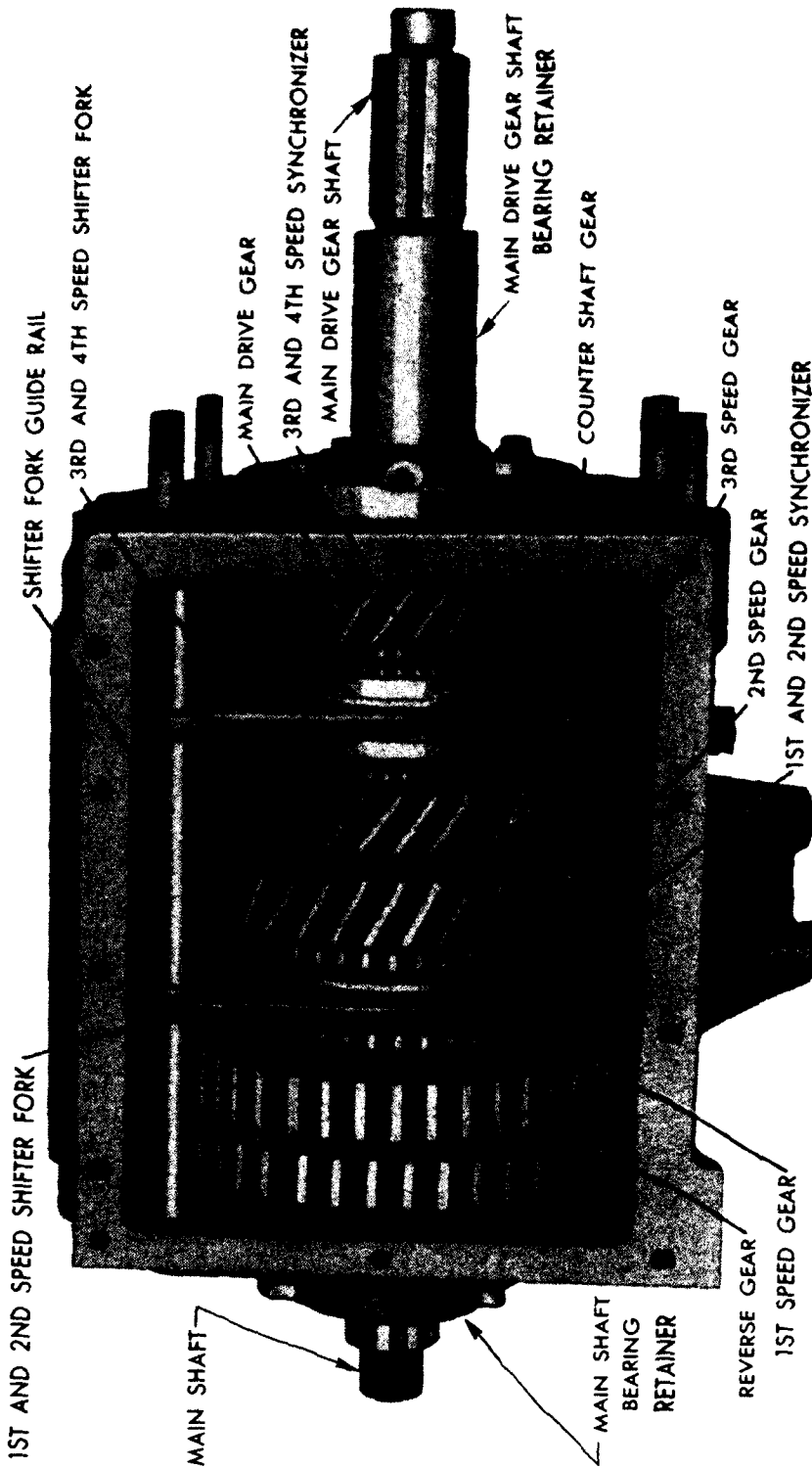
ASSEMBLY OF TRANSMISSION



RA PD 28321

Figure 23 — View of Transmission Shift Rails Installed in Case

ORDNANCE MAINTENANCE—POWER TRAIN, SUSPENSION, HULL,  
AND TURRET FOR ARMORED CAR M8 AND UTILITY CAR M20



RA PD 28324

Figure 24—Top View of Transmission with Cover Removed

## ASSEMBLY OF TRANSMISSION

shift rail spacer, reverse shifter head, and shift rail guide on the reverse shift rail. Hold the reverse fork in place on the idle gear, and push the reverse shift rail all the way in the case. Install the two fork lock screws in the shifter fork and guide. Make sure they are seated in the locking holes in the reverse shift rail, then install locking wire. Install socket head set screw in the reverse shifter head, making sure the screw is seated in the reverse shift rail. Be sure the shift rail is in neutral position.

b. **Install Third and Fourth Speed Shift Rail.** Drop two interlock balls in the case down on the reverse shift rail. Drop an interlock spring and ball in the center pocket of the case. Grease the interlock plunger to keep it from falling out of the shift rail when installing it and place it in the hole provided in the third and fourth speed shift rail. Press down on the ball and slide the third and fourth speed shift rail part way in the case. Hold third and fourth gear shifter fork in place on the synchronizer, and push the rail through the fork and shift rail guide. Install third and fourth gear shift rail snap ring on the third and fourth speed shift rail. Push the rail all the way in the case. Install the fork lock screw in the third and fourth gear shifter fork, making sure it is seated in the shift rail. Install locking wire in the lock screw. Be sure the rail is in neutral position.

c. **Install First and Second Speed Shift Rail.** Drop two interlock balls in the case down on the third and fourth speed shift rail. Drop an interlock spring and ball in the upper pocket of the case. Press down on the ball and slide the first and second speed shift rail part way in the case. Slide first and second gear shifter head on the rail. Hold the first and second gear shifter fork in place on the synchronizer. Push the rail through the fork. Slide the first and second shift rail spacer on the rail. Push the rail all the way in the case. Install fork lock screws in the fork and head, making sure they seat properly in the shift rail. Install lock wire in the lock screws. Push guide rail into the case and through both shifter forks.

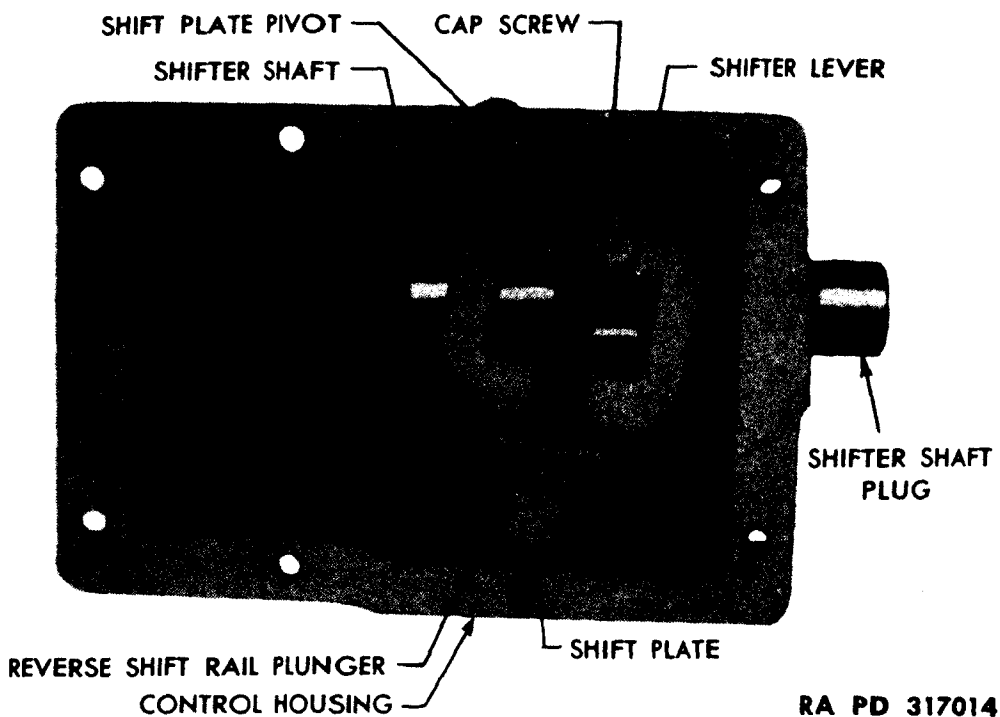
## 18. ASSEMBLY AND INSTALLATION OF CONTROL HOUSING.

a. **Assemble Control Housing** (fig. 25). Slide the solid end of the shifter shaft part way in the housing. Slide the shifter lever on the shaft, with the threaded side of the lever toward the reverse shift rail plunger. Tap the Woodruff key into the shaft with a brass hammer. Tap the shifter lever back onto the key and install the lock washer, cap screw, and lock wire. Install the reverse shift rail plunger,

**ORDNANCE MAINTENANCE—POWER TRAIN, SUSPENSION, HULL,  
AND TURRET FOR ARMORED CAR M8 AND UTILITY CAR M20**

reverse shifter housing spring, and the reverse shift rail plug in the housing. Install the shift plate, shift plate pivot, lock washer, and nut.

b. **Install Control Housing, Universal Joint Yoke, Clutch Housing and Release Bearing.** Place all three shifter forks in neutral position. Lay the control housing on the case, making sure the shift plate tongue is seated in the reverse shifter head and that the



**Figure 25—Under Side View of Control Housing**

first and second gear shifter head. Install the eight cap screws in the control housing. Slide the universal joint yoke on the main shaft, and install the nut and cotter pin. Slide the main drive gear bearing retainer on the shaft with the clutch release bearing return spring eye at the top. Install the four lock washers and cap screws. Place the clutch housing on the transmission, and install the lock washers and nuts. Slide the release bearing assembly onto the main drive gear bearing retainer, and connect the return spring to the release bearing and retainer. Fill the transmission case to the recommended level with lubricant specified in TM 9-743.

**CHAPTER 3**  
**PROPELLER SHAFTS, UNIVERSAL JOINTS AND**  
**PILLOW BLOCK**

**Section I**

**DESCRIPTION AND DATA**

	<b>Paragraph</b>
Description .....	19
Data .....	20

**19. DESCRIPTION.**

a. The propeller shafts and universal joints are used to transmit the power from engine to transfer case and to each of the three axles (fig. 26). The power line to the rear axle consists of a propeller shaft running from the transfer case to a pillow block on the intermediate axle and another propeller shaft running from the pillow block to the rear axle.

**20. DATA.**

**a. Universal Joints.**

Number used ..... 10  
Type of bearings ..... Needle  
Connected to drives by ..... Splined slip joints  
Make ..... Spicer

**b. Propeller Shafts.**

Number used ..... 5  
Type ..... Tubular

**c. Pillow Block.**

Make ..... Timken  
Number used ..... 1  
Type of bearings ..... Tapered roller bearings

ORDNANCE MAINTENANCE—POWER TRAIN, SUSPENSION, HULL,  
AND TURRET FOR ARMORED CAR M8 AND UTILITY CAR M20

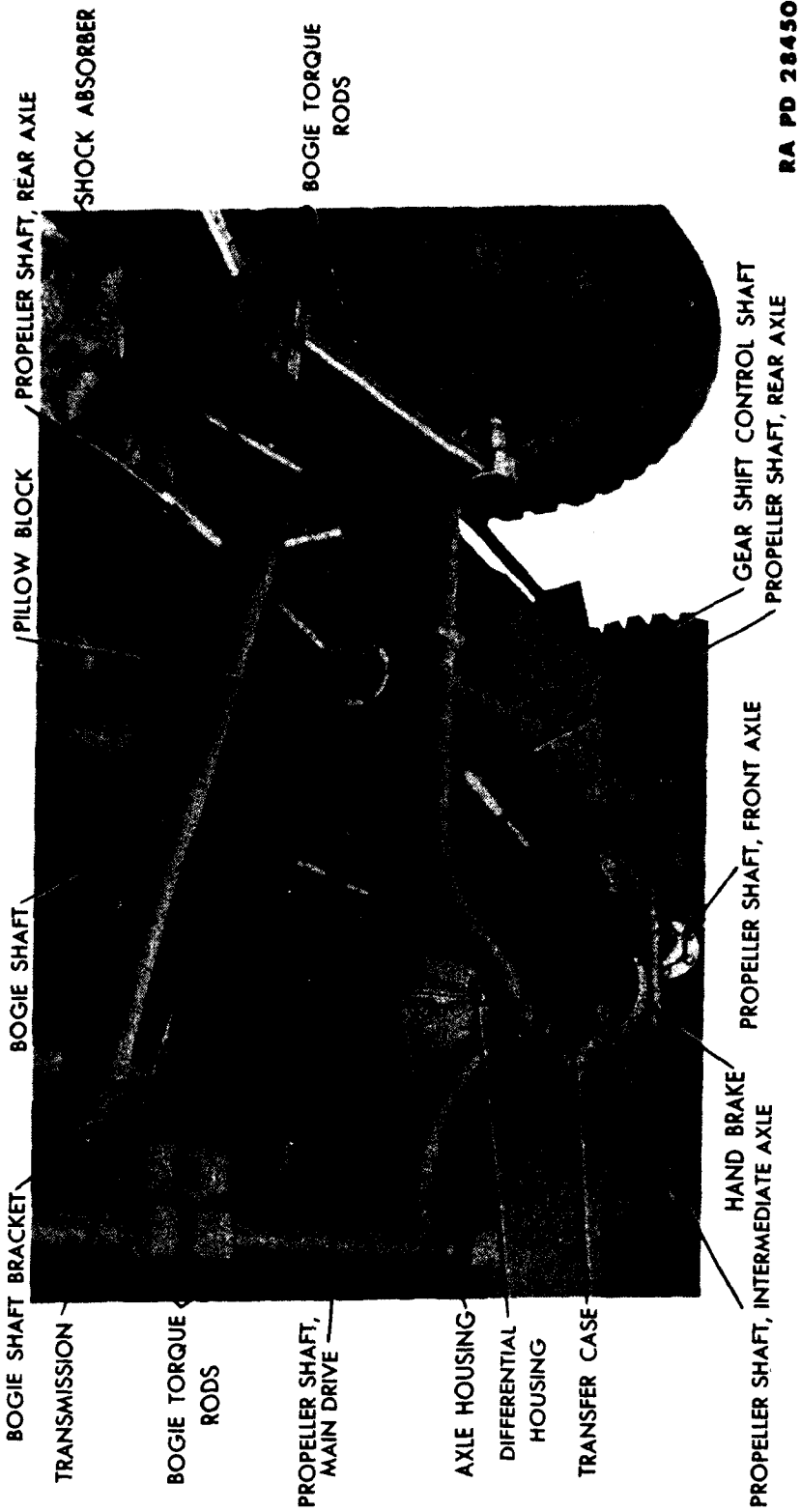


Figure 26—Under Side View Showing Propeller Shafts

**CHAPTER 3**  
**PROPELLER SHAFTS, UNIVERSAL JOINTS AND**  
**PILLOW BLOCK (Cont'd)**

**Section II**

**PROPELLER SHAFTS AND UNIVERSAL JOINTS**

	<b>Paragraph</b>
Description .....	21
Disassembly (solid yoke type) .....	22
Disassembly (U-bolt type) .....	23
Cleaning and inspection of parts .....	24
Assembly (solid yoke type) .....	25
Assembly (U-bolt type) .....	26

**21. DESCRIPTION.**

a. Two types of propeller shafts and universal joints are provided; the solid yoke and the U-bolt type (figs 27 and 28). Each propeller shaft slip joint is located at the forward end of the vehicle with the exception of the propeller shafts running from the transfer case to the transmission and from the transfer case to the front axle. On these shafts the slip joint is located at the rear.

**22. DISASSEMBLY (SOLID YOKE TYPE).**

a. **Preliminary Work.** Bend down the four locking lugs on the two bearing caps on the universal slip joint yokes. Remove the four cap screws, two locking lugs, and the two bearing caps. Remove the grease fitting from the trunnion.

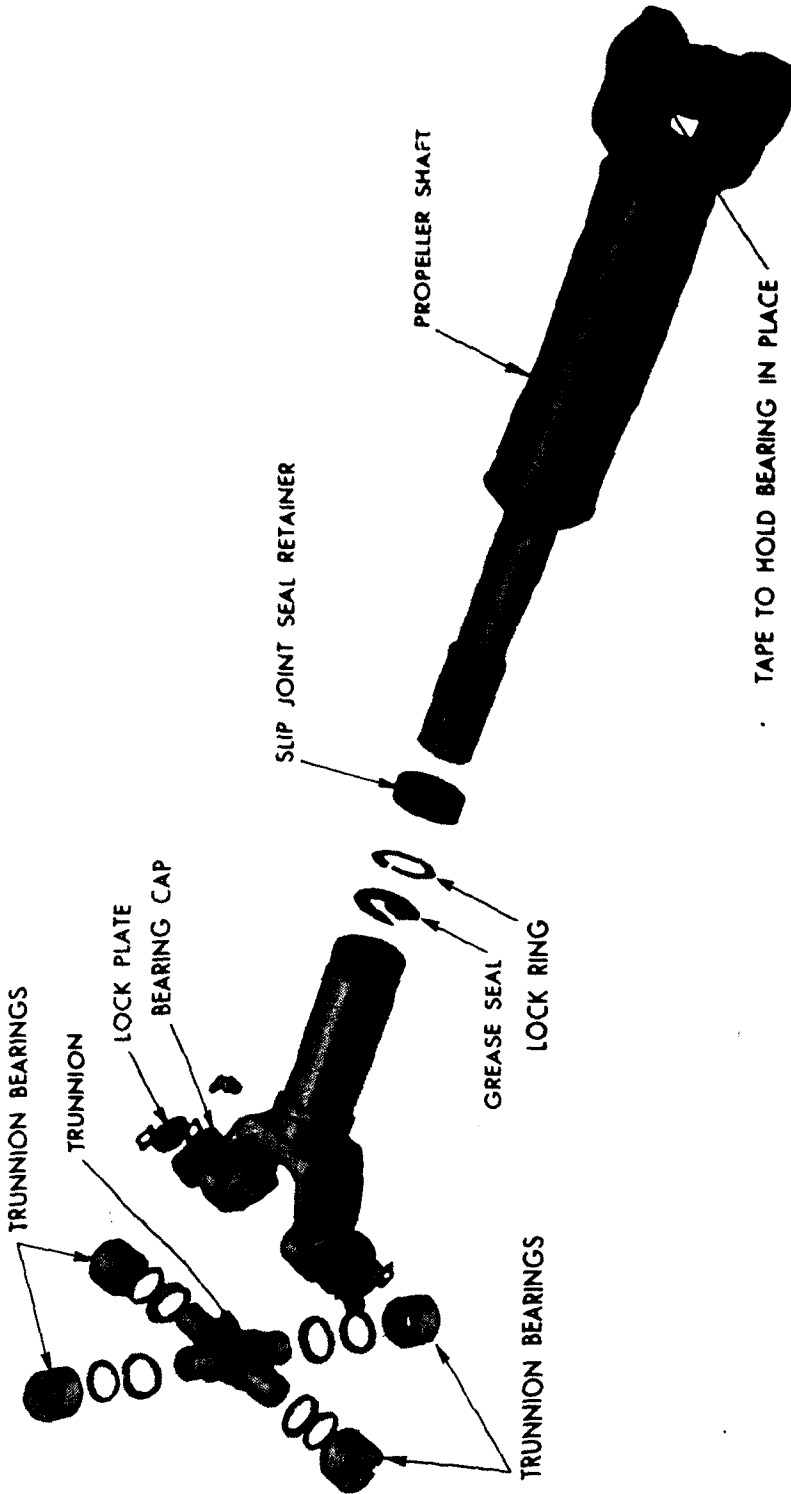
b. **Remove Trunnion From Yoke.** Place the propeller shaft in a vise. Drive lightly on the exposed face of the trunnion bearing with a brass driver, until the opposite bearing comes out. Reverse the position of the slip joint assembly in the vise. Drive on the exposed face of the trunnion with a brass driver until the other bearing assembly comes out. Lift the trunnion from the propeller shaft. Repeat the same removal procedure on the other end of the propeller shaft.

**23. DISASSEMBLY (U-BOLT TYPE).**

a. **Preliminary Work.** Remove the grease fitting from the trunnion. Remove the two snap rings that hold the trunnion and bearings in the universal slip joint. Place the universal slip joint in a vise, with the grease fitting, opening facing upward.



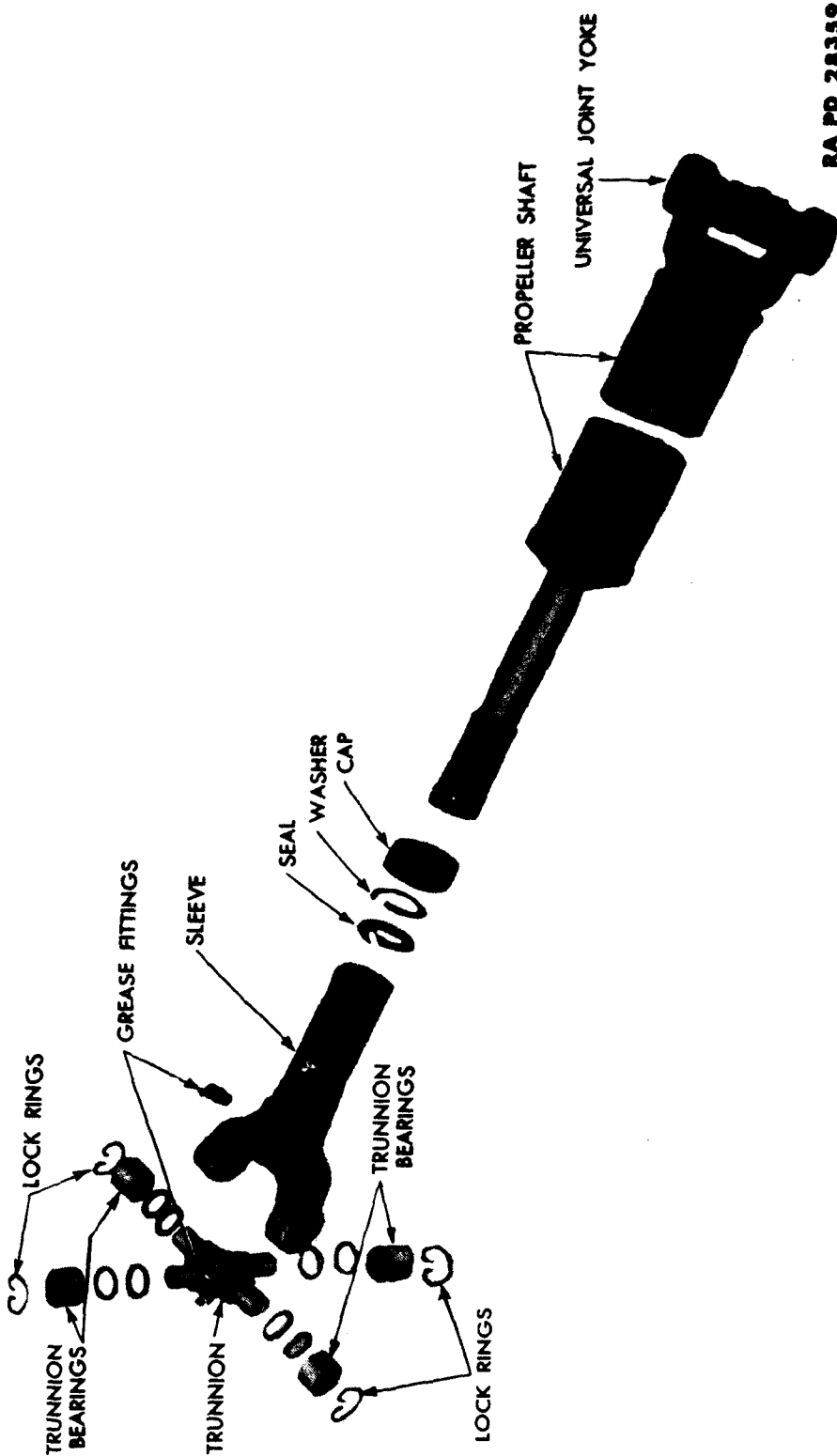
ORDNANCE MAINTENANCE—POWER TRAIN, SUSPENSION, HULL,  
AND TURRET FOR ARMORED CAR M8 AND UTILITY CAR M20



RA PD 28121

Figure 27 — Propeller Shaft, Disassembled (Solid Yoke Type)

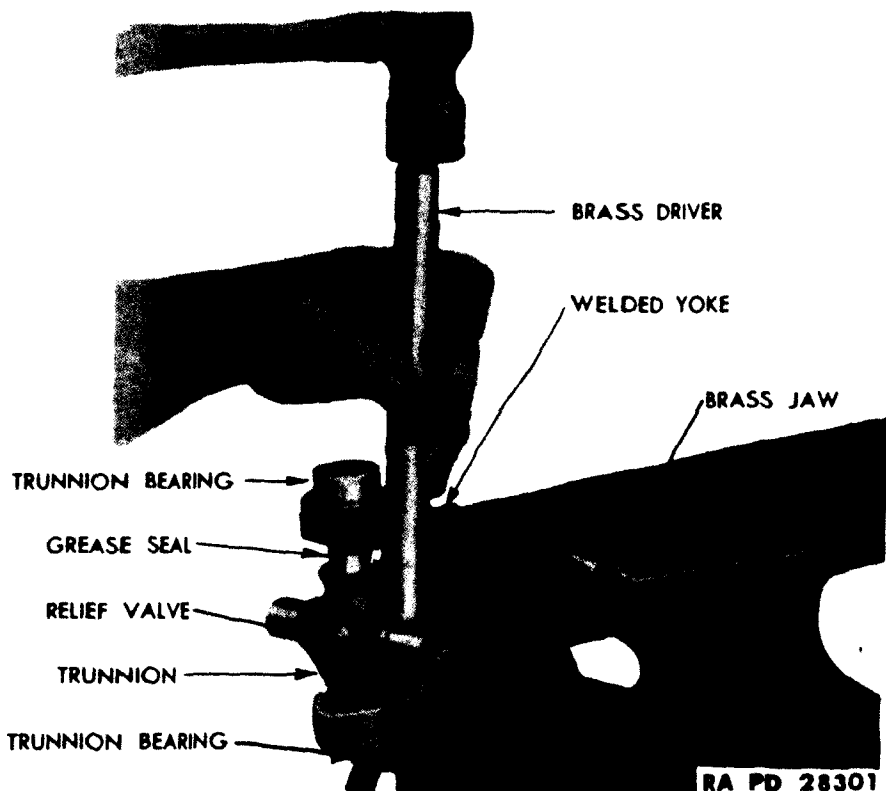
PROPELLER SHAFTS AND UNIVERSAL JOINTS



RA PD 28359

Figure 28—Propeller Shaft, Disassembled (U-Bolt Type)

**ORDNANCE MAINTENANCE—POWER TRAIN, SUSPENSION, HULL,  
AND TURRET FOR ARMORED CAR M8 AND UTILITY CAR M20**

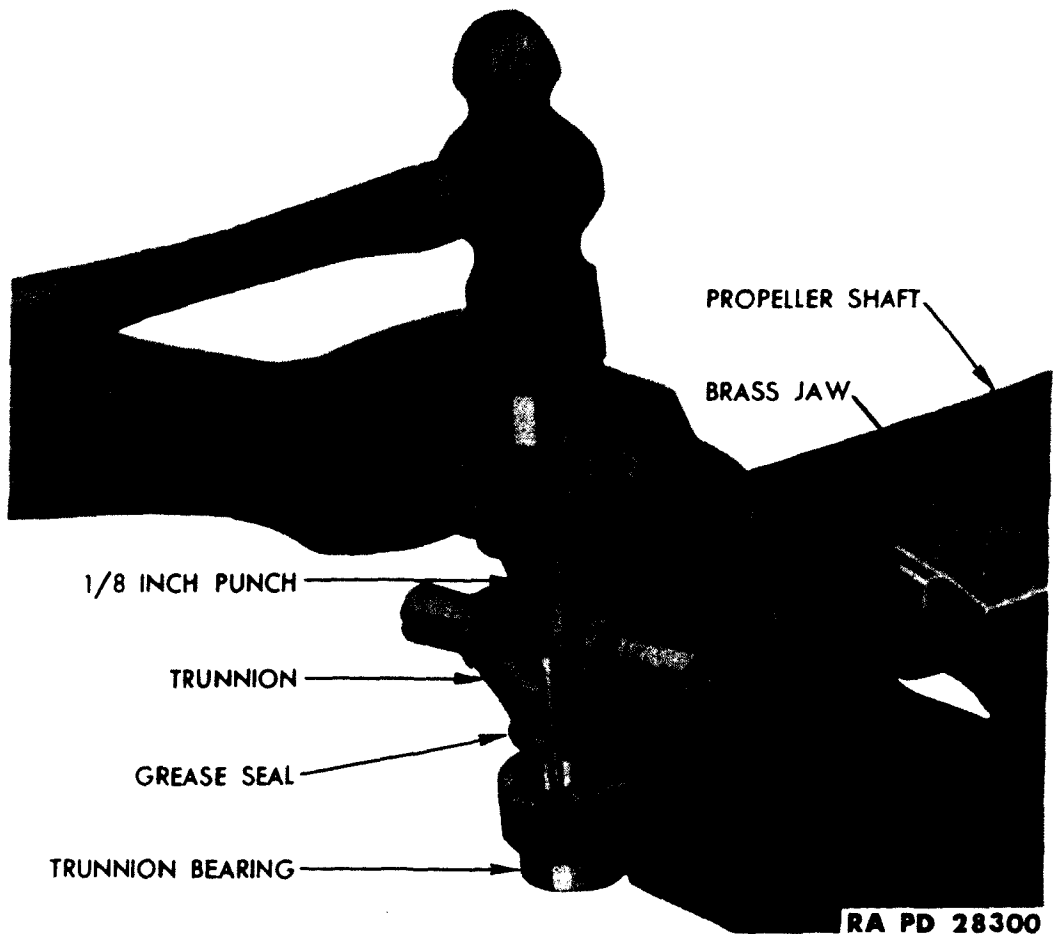


**Figure 29—Driving Trunnion Bearing from Yoke (U-Bolt Type)**

b. **Remove Trunnion from Yoke.** Drive down on the exposed face of the trunnion bearing with a brass drift until the opposite bearing assembly comes out. Reverse the position of the universal slip joint in the vise. Drive down on the exposed face of the trunnion with a brass drift until the trunnion touches the yoke. Lift the trunnion up and out of the universal slip joint yoke.

c. **Remove Trunnion from Welded Yoke.** Remove the grease fitting from the trunnion (in the welded yoke). Remove the two snap rings that hold the trunnion and bearings in the welded yoke. Place the propeller shaft in the vise. Drive down on the exposed face of the trunnion bearing with a brass driver until the trunnion touches the yoke. Reverse the position of the propeller shaft in the vise. Drive the trunnion down (fig. 29) with a brass drift until the trunnion touches the yoke. Lift the trunnion up and, with a  $\frac{1}{8}$ -inch punch, drive the trunnion bearing from the yoke (fig. 30). Lift the trunnion from the welded yoke. Drive the remaining trunnion bearing from the yoke with a brass driver.

## PROPELLER SHAFTS AND UNIVERSAL JOINTS



**Figure 30—Driving Trunnion Bearing from Yoke with a 1/8-Inch Punch**

### 24. CLEANING AND INSPECTION OF PARTS.

a. **Propeller Shafts (Both Types).** Clean all parts thoroughly with dry-cleaning solvent. Inspect the propeller shafts for cracks, broken welds, scored trunnion bearing surfaces, or bent shafts. Replace parts with any of these defects.

b. **Universal Joints (Both Types).** Inspect the universal joints for worn splines, worn bearing surfaces and bearings, plugged lubricant fittings and relief valves. Parts with any of these defects will be replaced.

### 25. ASSEMBLY (SOLID YOKE TYPE).

a. Place the propeller shaft in a vise. Slip the trunnion into the yoke with the relief valve facing outward. Pack all trunnion bearings with chassis grease. Tap a trunnion bearing approximately  $\frac{1}{4}$  inch into the yoke, with the slot in the trunnion bearing face in line with tapped holes. Lift the trunnion into the bearing, and tap the

**ORDNANCE MAINTENANCE—POWER TRAIN, SUSPENSION, HULL,  
AND TURRET FOR ARMORED CAR M8 AND UTILITY CAR M20**

bearing into the yoke until the bearing face is flush with the yoke. Install the bearing cap with the key portion engaging slot in bearing. Install the locking lug and cap screws. Bend down the two locking lugs. Reverse the position of the propeller shaft, and repeat the same procedure on the other bearing assembly. Install the grease fitting in the trunnion. Repeat the above procedure on the other end of the propeller shaft. Lubricate the universal joints, using approved lubricant.

**26. ASSEMBLY (U-BOLT TYPE).**

**a. Assemble Trunnion in Yoke.** Place the propeller shaft in a vise. Slip the trunnion into the yoke with the relief valve facing outward. Pack all trunnion bearings with chassis grease. With a brass hammer, tap a trunnion bearing approximately  $\frac{1}{4}$  inch into the yoke. Lift the trunnion up into the bearing assembly, and tap the bearing with a brass hammer until the bearing face is flush with the yoke. Reverse the position of the propeller shaft in the vise. Tap the other trunnion bearing into the yoke approximately  $\frac{1}{4}$  inch. Lift the trunnion up into the trunnion bearing, and tap the bearing until the bearing face is flush with the yoke.

**b. Install Snap Rings and Grease Fitting.** Drive down on the trunnion bearing until it is flush with the lower edge of the snap ring groove, and install the snap ring. Reverse the position of the propeller shaft in the vise, and drive the other bearing down flush with the lower edge of the snap ring groove, and install the snap ring. Install the grease fitting in the trunnion. Repeat the same procedure on the universal slip joint yoke. Rock the trunnion in both yokes to be sure there is no binding. Lubricate the universal joints, using approved lubricant.

**CHAPTER 3**  
**PROPELLER SHAFTS, UNIVERSAL JOINTS AND**  
**PILLOW BLOCK (Cont'd)**

**Section III**  
**PILLOW BLOCK**

	<b>Paragraph</b>
Description and data .....	27
Disassembly .....	28
Cleaning and inspection of parts .....	29
Assembly .....	30

**27. DESCRIPTION AND DATA.**

a. The pillow block, mounted on top of the intermediate axle (fig. 26), is a part of the drive line, running from the transfer case to the rear axle. See page 45 for data.

**28. DISASSEMBLY.**

a. **Drain the Pillow Block.** Remove the filler and/or drain plug and drain the pillow block.

b. **Remove Universal Joint Yokes from Drive Shaft.** Remove the cotter pin and castellated nut that hold each universal joint yoke on the drive shaft. With a brass hammer, tap each universal joint yoke off the drive shaft.

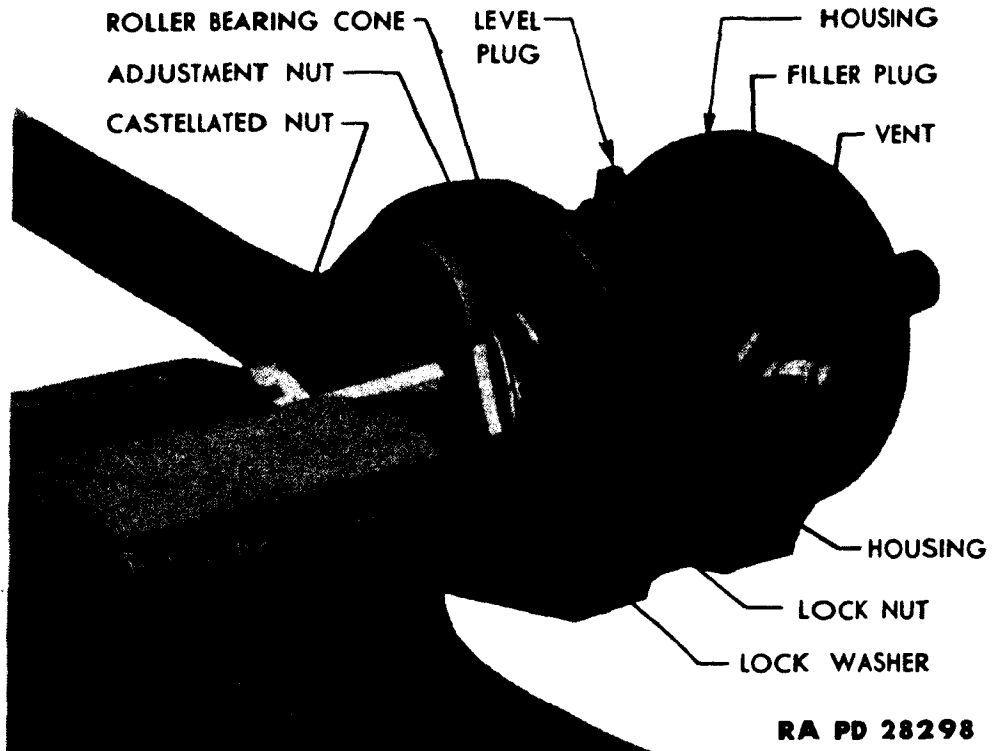
c. **Remove Grease Retainer Housing Assemblies.** Remove the six cap screws, six lock washers, and flange washer that hold each grease retainer assembly to the pillow block housing. Lift the grease retainer housings from the pillow block.

d. **Remove Drive Shaft from Pillow Block Housing.** Install the universal joint yoke nut on the adjustment nut end of the drive shaft. Place the pillow block assembly in a vise (fig. 31). Straighten tab on lock washer and remove lock nut and washer. Remove adjustment nut and spacer washer. Remove the assembly from the vise and remove universal joint yoke nut. Slip the drive shaft and front roller bearing from the housing.

**29. CLEANING AND INSPECTION OF PARTS.**

a. **General.** During the inspection of parts, the inspector must record the condition of each part and make recommendations regarding the repair or disposition of each part. Instructions covering con-

**ORDNANCE MAINTENANCE—POWER TRAIN, SUSPENSION, HULL,  
AND TURRET FOR ARMORED CAR M8 AND UTILITY CAR M20**



RA PD 28298

**Figure 31—Pillow Block Assembly in Vise**

dition of gaskets and seals are intentionally omitted. These parts are to be replaced at every overhaul.

**b. Cleaning.** Clean all parts thoroughly with dry-cleaning solvent.

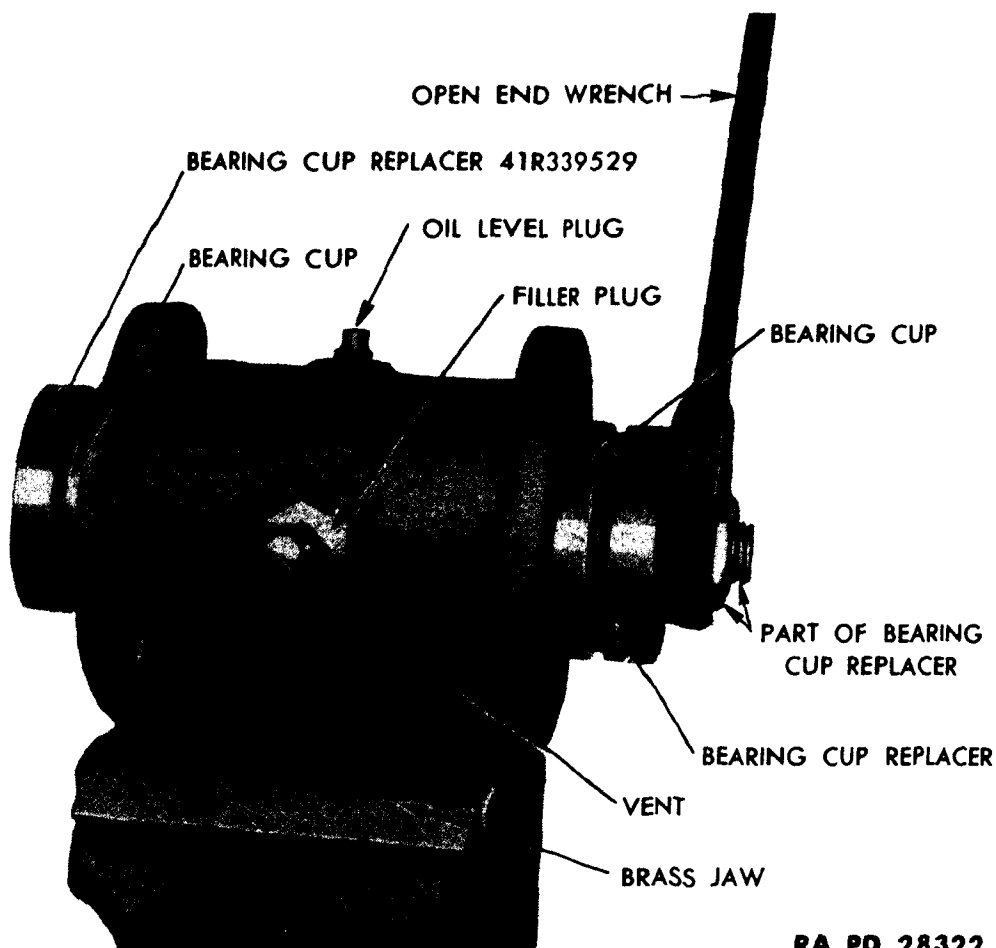
**c. Inspection.**

(1) **INSPECT PILLOW BLOCK HOUSING.** Inspect the housing for cracks or damage of any kind. Any housing found cracked must be replaced. Inspect the air vent for a broken spring. If the spring is broken, the air vent must be replaced. Inspect the bearing cups for ridges and cracks. Bearing cups that have ridges indicate excessive wear and should be replaced. Cracked bearing cups must be replaced.

(2) **REPLACE BEARING CUP.** Drive the bearing cups from the housing with a driver. Install the two bearing cups in pillow block housing with bearing cup replacer (41-R-2395-29) (fig. 32).

(3) **INSPECT DRIVE SHAFT.** A drive shaft showing excessive wear at the Woodruff key slot will be discarded. Pitted, corroded or discolored bearings, due to overheating, must be replaced.

**PILLOW BLOCK**



RA PD 28322

**Figure 32—Installing Bearing Cups in Pillow Block Housing with Replacer 41-R-2395-29**

**30. ASSEMBLY.**

a. **Install Drive Shaft in Housing.** Press the tapered roller bearing on the drive shaft. Place the pillow block housing in upright position. Insert the drive shaft and bearing from the left-hand side of the housing. Install the other tapered roller bearing, spacer washer, adjustment nut, lock washer, and lock nut. Install a universal joint yoke nut on the opposite end of the drive shaft and place the assembly in a vise. Run the adjustment nut up tight, then back it off  $\frac{1}{8}$  turn. Tighten the lock nut and check the adjustment. Correct adjustment is obtained when the shaft turns freely but has no end play. When the correct adjustment is obtained, bend the tab on the washer down on the lock nut.

b. **Install Grease Retainer Assemblies.** Install the two grease retainer assemblies, but do not tighten the bolts. Install the long



**ORDNANCE MAINTENANCE—POWER TRAIN, SUSPENSION, HULL,  
AND TURRET FOR ARMORED CAR M8 AND UTILITY CAR M20**

grease retainer housing on the lock nut side of the drive shaft and the short retainer housing on the opposite end of the pillow block housing.

c. **Install Universal Joint Flange Yokes.** With a brass hammer, tap a key in the slot in each end of the drive shaft with the tapered end of the key toward the bearing. Slide the universal joint yokes on the drive shaft, and install the castellated nuts and washers. Rotate the shaft in its bearings to see that the outside diameter of the universal joint flange hub does not run out. Tighten the cap screws holding grease retainer to housing.

## CHAPTER 4 TRANSFER CASE

### Section I

### DESCRIPTION AND DATA

	Paragraph
Description .....	31
Data .....	32

#### 31. DESCRIPTION.

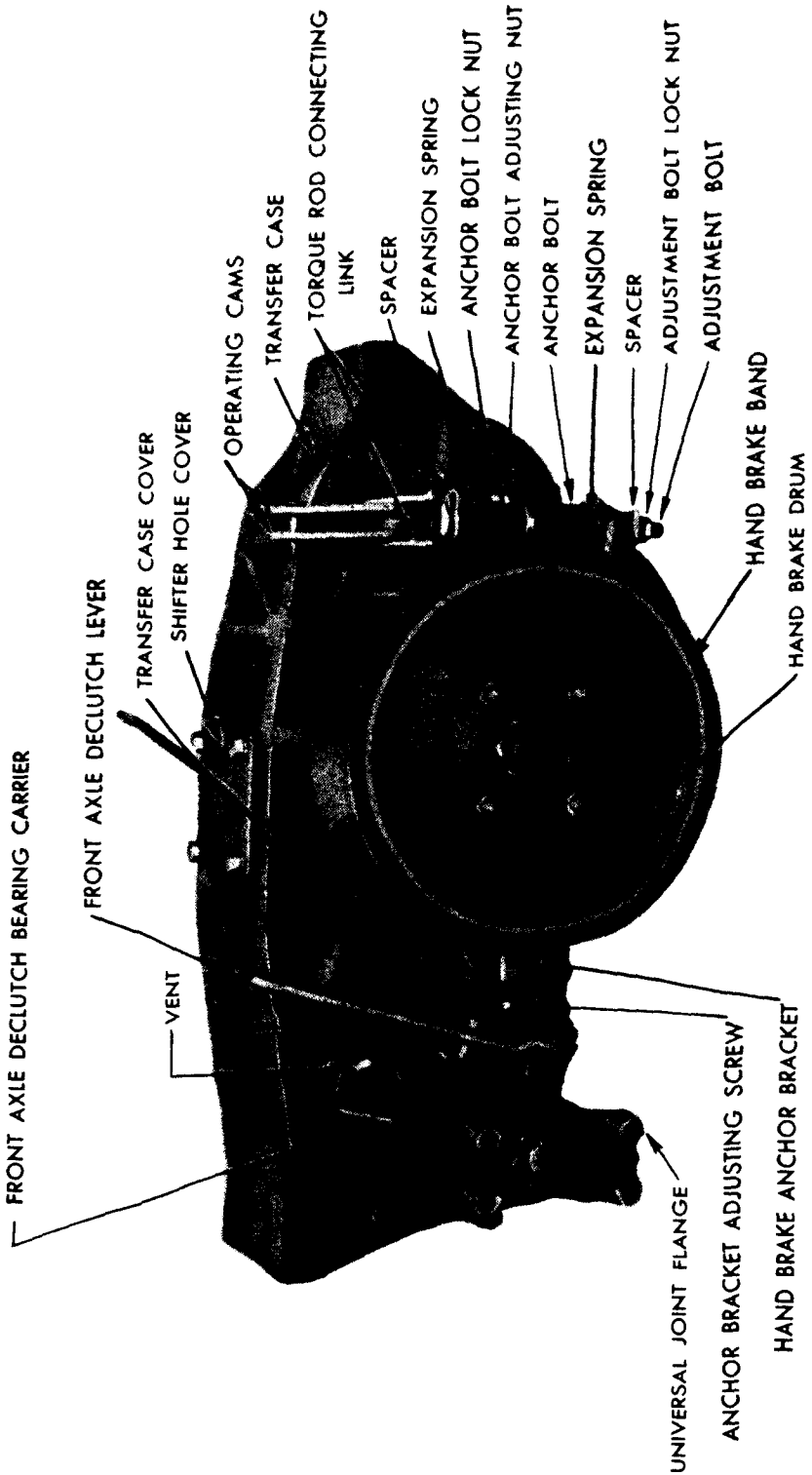
a. The Light Armored Car M8 and the Armored Utility Car M20 are each equipped with a two-speed transfer case provided with a front axle declutch (fig. 33). The transfer case is located on the under side of the cross member, midway between the front and intermediate axles (fig. 34).

#### 32. DATA.

Ratios:

High gear .....	1.000 to 1
Low gear .....	1.956 to 1
Make .....	Warner Gear
Model .....	J5-1

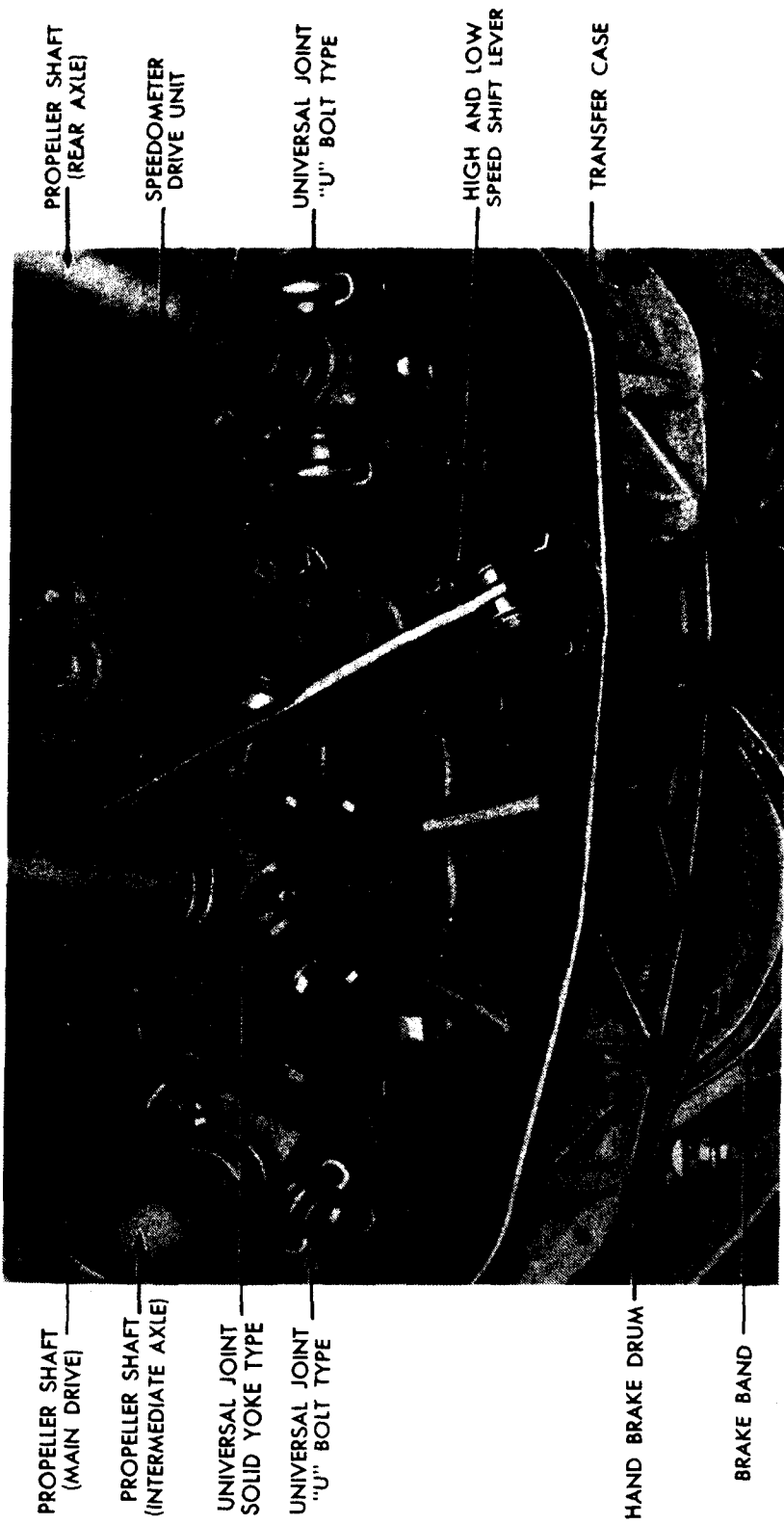
ORDNANCE MAINTENANCE—POWER TRAIN, SUSPENSION, HULL,  
AND TURRET FOR ARMORED CAR M8 AND UTILITY CAR M20



RA PD 317016

Figure 33—Front View of Transfer Case

DESCRIPTION AND DATA



RA PD 28449

Figure 34—Transfer Case in Vehicle

**ORDNANCE MAINTENANCE—POWER TRAIN, SUSPENSION, HULL,  
AND TURRET FOR ARMORED CAR M8 AND UTILITY CAR M20**

**CHAPTER 4**

**TRANSFER CASE (Cont'd)**

**Section II**

**DISASSEMBLY OF TRANSFER CASE**

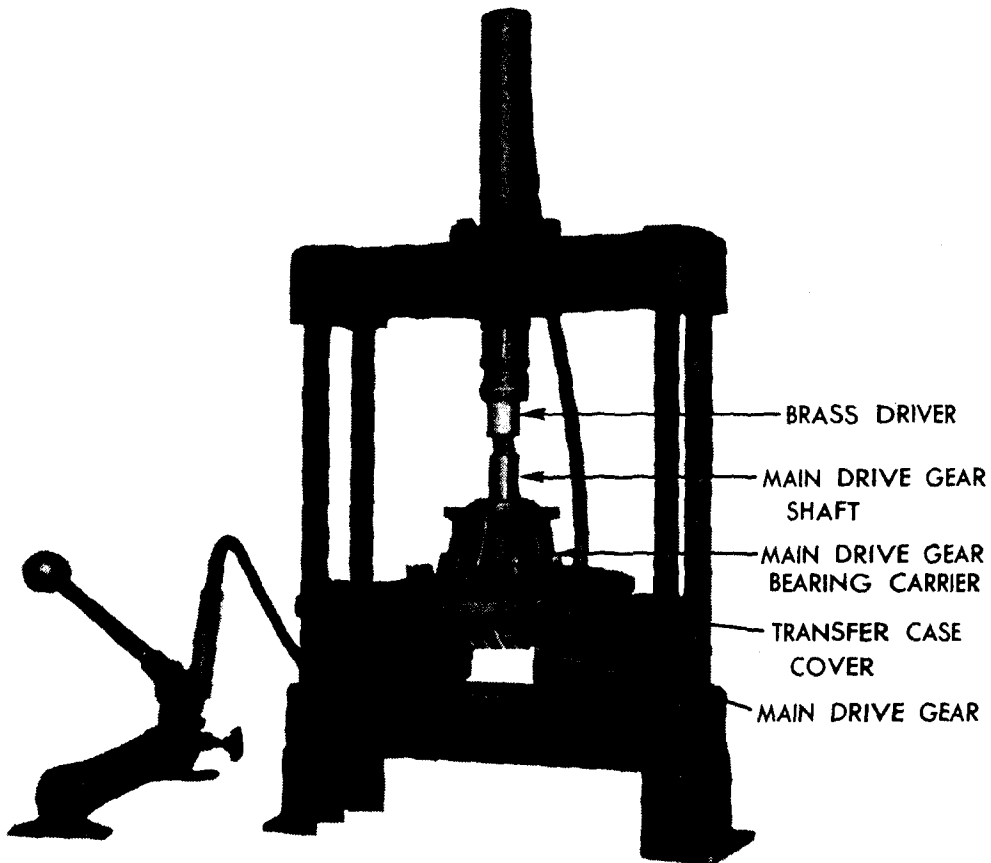
Paragraph

Disassembly of transfer case..... 33

**33. DISASSEMBLY OF TRANSFER CASE.**

**a. Remove Universal Joint Flanges.** Remove the cotter pin and castellated nut that hold each universal joint flange to the shaft. Pull the universal joint flanges off the shafts.

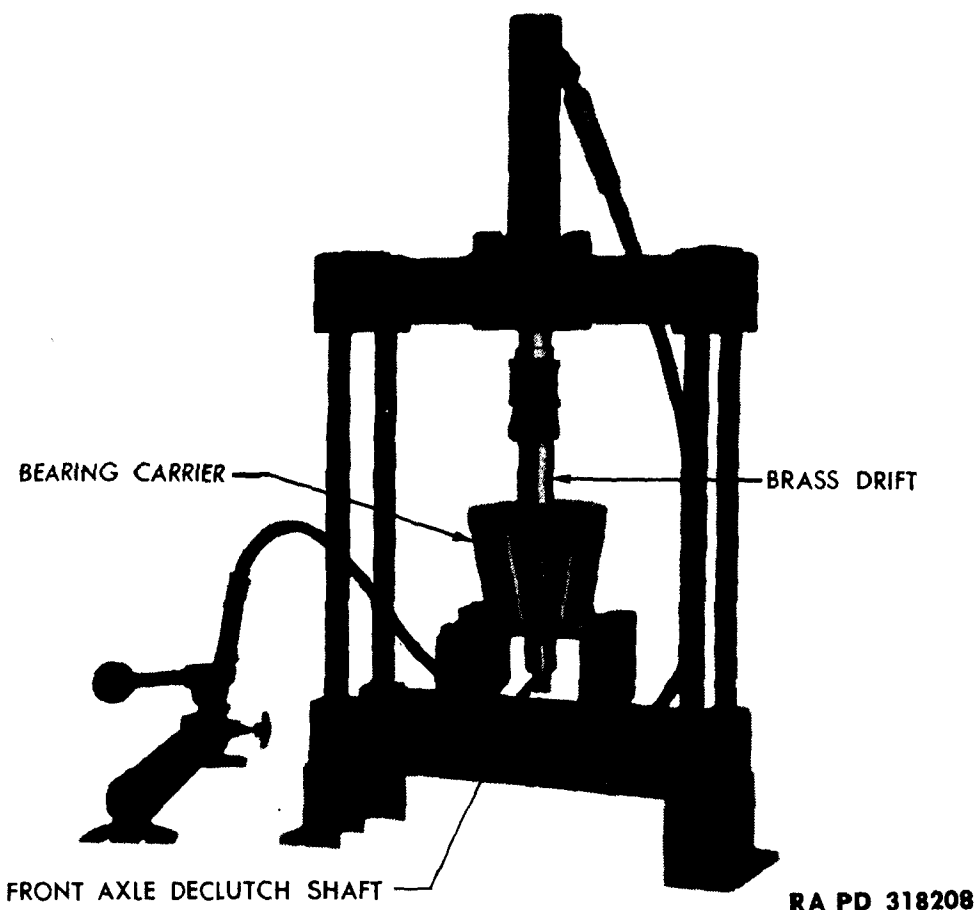
**b. Remove Hand Brake Drum and Band (fig. 33).** Remove the four nuts, lock washers, and bolts that hold the band brake drum to



RA PD 317017

**Figure 35—Pressing Main Drive Gear Shaft from  
Bearing Carrier and Cover**

## DISASSEMBLY OF TRANSFER CASE



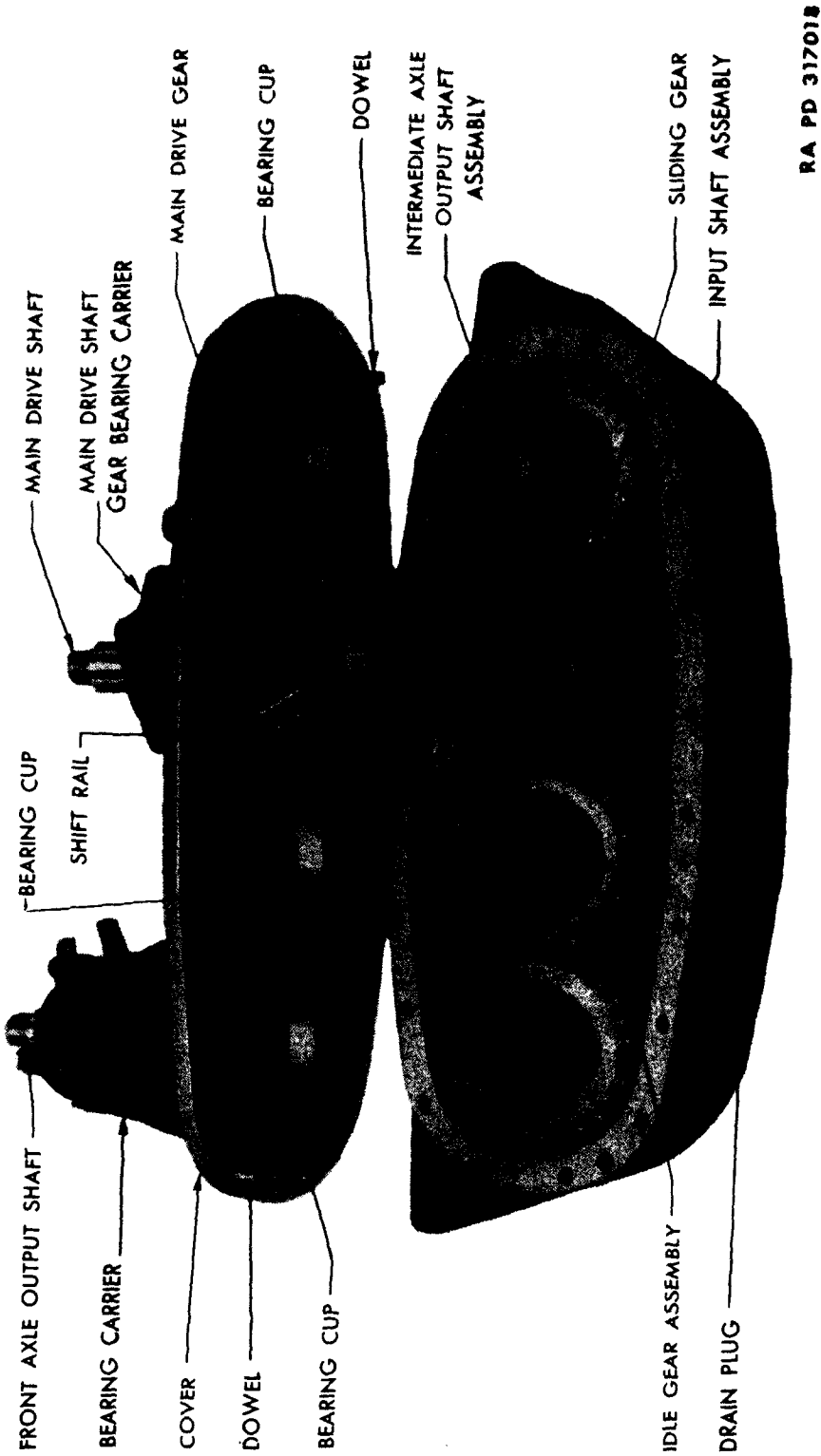
**Figure 36—Pressing Front Axle Declutch Shaft from Bearing Carrier**

the flange. Slide the drum out of the brake band. Remove the cotter pin and castellated nut from the main drive gear shaft and slide the flange off the shaft. Remove the cotter pin and clevis pin that connect the adjusting bolt and the operating cam. Remove the operating cam. Remove the lock nut, lock washer, and adjusting nut from the adjusting bolt. Lift out the adjusting bolt, and remove the two spacer plates and the two expansion springs. Remove the lock wire from the support bolt and remove the bolt. Slide the hand brake band off the hand brake anchor bracket, being careful not to lose the support bolt expansion spring that is concealed in the hand brake anchor bracket.

c. **Remove Hand Brake Anchor Bracket.** Remove the four cap screws that hold the hand brake anchor bracket to the hand brake shaft bearing carrier. Pry or tap the hand brake anchor bracket off the bearing carrier.

d. **Remove Shifter Fork.** Remove the 20 cap screws that hold the transfer case cover to the case and lift off the cover. Remove the

ORDNANCE MAINTENANCE—POWER TRAIN, SUSPENSION, HULL,  
AND TURRET FOR ARMORED CAR M8 AND UTILITY CAR M20



RA PD 317018

Figure 37—Inside View of Transfer Case

## DISASSEMBLY OF TRANSFER CASE

four cap screws that hold the shifter hole cover to the transfer case and lift off the cover. Remove the shift rail interlocking ball and spring from the case. Remove the lock wire from the shifter fork lock screw and remove the screw. Slide the shift rail from the case. Lift the shifter fork out of the case.

e. **Disassemble Main Drive Gear Bearing Carrier.** Place the main drive gear assembly in a press. Press the main drive gear from the bearing carrier and transfer case cover (fig. 35). Remove the six cap screws that hold the bearing carrier to the transfer case cover and remove the bearing carrier.

f. **Disassemble Front Axle Declutch Shaft Bearing Carrier.** Remove the six cap screws that hold the front axle declutch bearing carrier to the transfer case cover and remove the bearing carrier assembly. Remove the interlocking spring plug, interlocking ball and spring from the bearing carrier. Remove the filler plug from the bearing carrier. Working through the filler plug opening, remove the declutch shifter fork lock screw from the shifter fork. Slide the declutch shift rail from the bearing carrier. Slide the front axle declutch sleeve off the shaft. Remove declutch bearing carrier cap. Place the bearing carrier and shaft in the press. Press the shaft and bearing assembly from the bearing carrier (fig. 36).

g. **Remove Gear and Shaft Assemblies from Case** (fig. 37). Lift the shafts from the case in the following order: intermediate axle output shaft assembly, rear axle output shaft assembly, input shaft assembly and idle gear assembly.



**ORDNANCE MAINTENANCE—POWER TRAIN, SUSPENSION, HULL,  
AND TURRET FOR ARMORED CAR M8 AND UTILITY CAR M20**

**CHAPTER 4**

**TRANSFER CASE (Cont'd)**

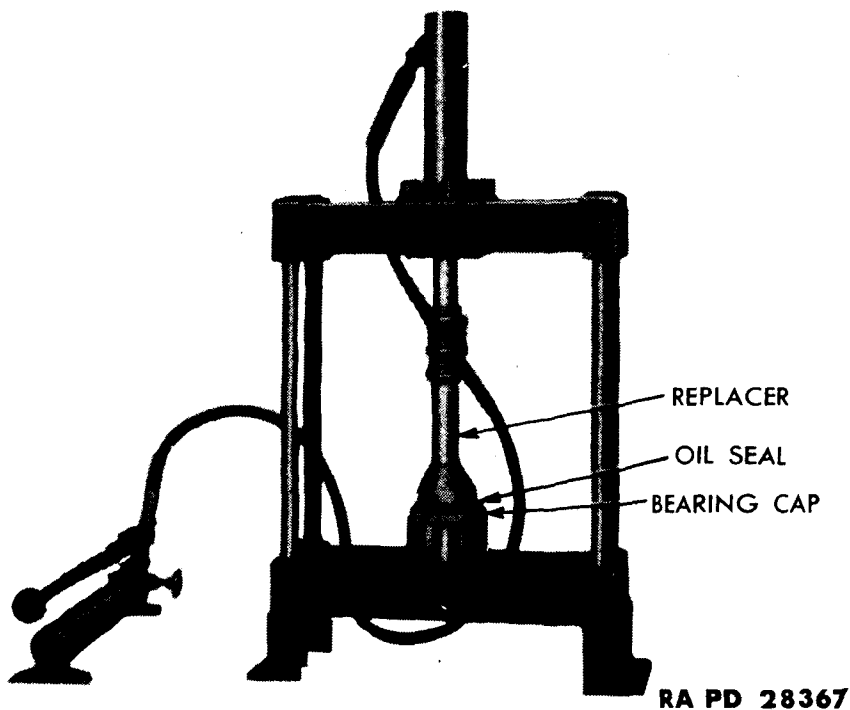
**Section III**

**TRANSFER CASE CLEANING, INSPECTION AND REPAIR**

	Paragraph
Cleaning .....	34
Case, cover, and bearing carriers .....	35
Front axle declutch shaft assembly .....	36
Rear axle output shaft assembly .....	37
Idle shaft assembly .....	38
Intermediate axle output shaft assembly .....	39
Input shaft assembly .....	40
Main drive gear and shaft .....	41
Shift mechanism .....	42

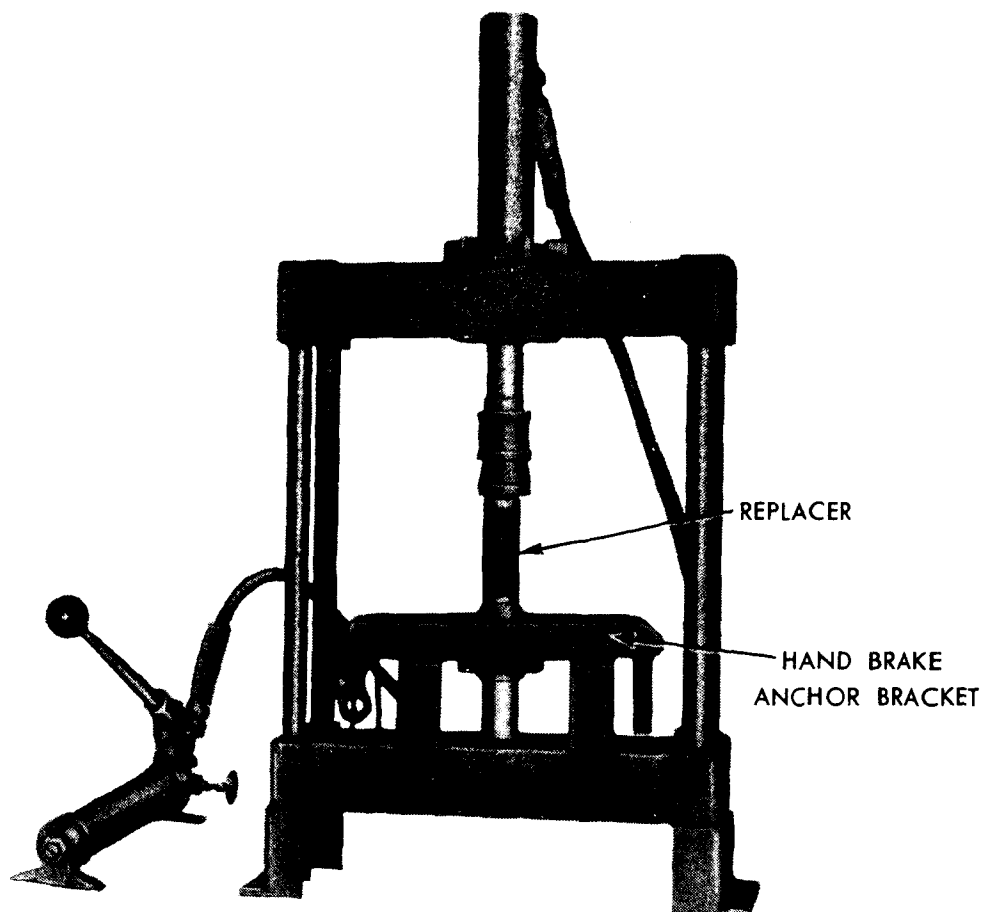
**34. CLEANING.**

- a. Wash all parts thoroughly in dry-cleaning solvent. Immerse the roller bearings in a container of dry-cleaning solvent, and rotate the



**Figure 38—Pressing Oil Seal in Bearing Cap with Replacer 41-R-2390-600**

**TRANSFER CASE CLEANING, INSPECTION AND REPAIR**



RA PD 28288

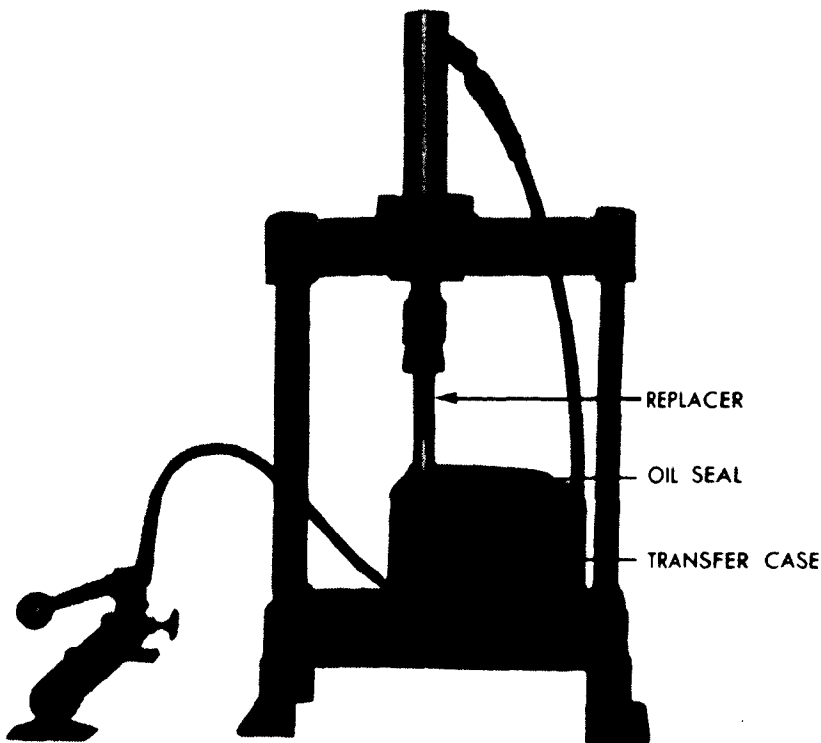
**Figure 39—Pressing Oil Seal in Hand Brake Anchor Bracket with Replacer 41-R-2390-600**

bearings until all trace of lubricant has been removed. Oil the bearings immediately to prevent corrosion of the highly polished surfaces.

**35. CASE, COVER, AND BEARING CARRIERS.**

a. Inspect the case for cracks or damage of any kind. A cracked case, cover or bearing carrier must be replaced. Replace all oil seals with replacer (41-R-2390-600) (fig. 38), and attach the shims to the respective cap or cover with a small wire so that the same quantity of shims may be used during reassembly. Replace the shifter shaft oil seal with replacer (41-R-2396-27) (fig. 40). Replace the drain plug, if it has lost its magnetic strength. Do not remove shifter shaft plug unless replacement is necessary. A damaged or loose shifter shaft plug must be replaced. Drive the shifter shaft plug in the cover with replacer (41-R-2395-150) (fig. 41). Replace any bearing cups that

**ORDNANCE MAINTENANCE—POWER TRAIN, SUSPENSION, HULL,  
AND TURRET FOR ARMORED CAR M8 AND UTILITY CAR M20**



RA PD 28286

**Figure 40—Pressing Shifter Shaft Oil Seal in Transfer Case Housing with Replacer 41-R-2396-27**

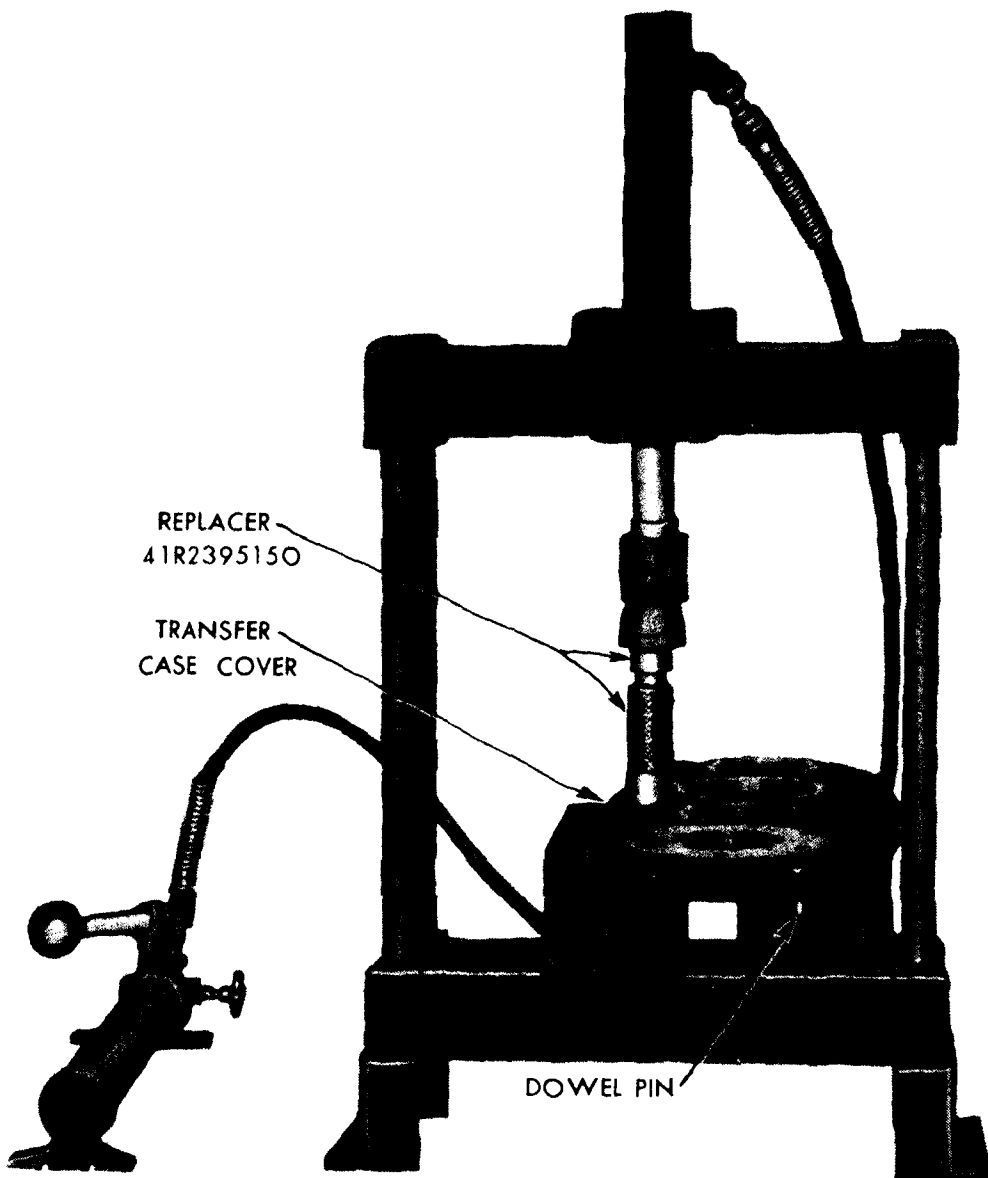
are ridged, worn, or scored. Place the case or cover in the press. Remove the bearing cups with the bearing cup remover and replacer (41-R-2385-115) (fig. 42). Press all the bearing cups in the case or cover with bearing cup remover and replacer (41-R-2385-115) until they are flush with the cover or case.

**36. FRONT AXLE DECLUTCH SHAFT ASSEMBLY.**

**a. Inspection.** A twisted shaft or a shaft with worn or broken splines must be replaced. A cracked declutch sleeve or a sleeve with excessively worn splines must be replaced. Shafts or sleeves with small nicks can be honed and then polished with a fine stone. Pitted, corroded, or discolored bearings, due to overheating, must be replaced.

**b. Disassemble.** Press the two bearing cones and spacer off the shaft.

**c. Assemble.** Press a bearing cone onto the front end of the front axle declutch shaft, with the small end of the cone against the shoulder. Press the spacer and other bearing cone onto the same end of the shaft, with the large end of cone against the spacer.

**TRANSFER CASE CLEANING, INSPECTION AND REPAIR**

RA PD 28287

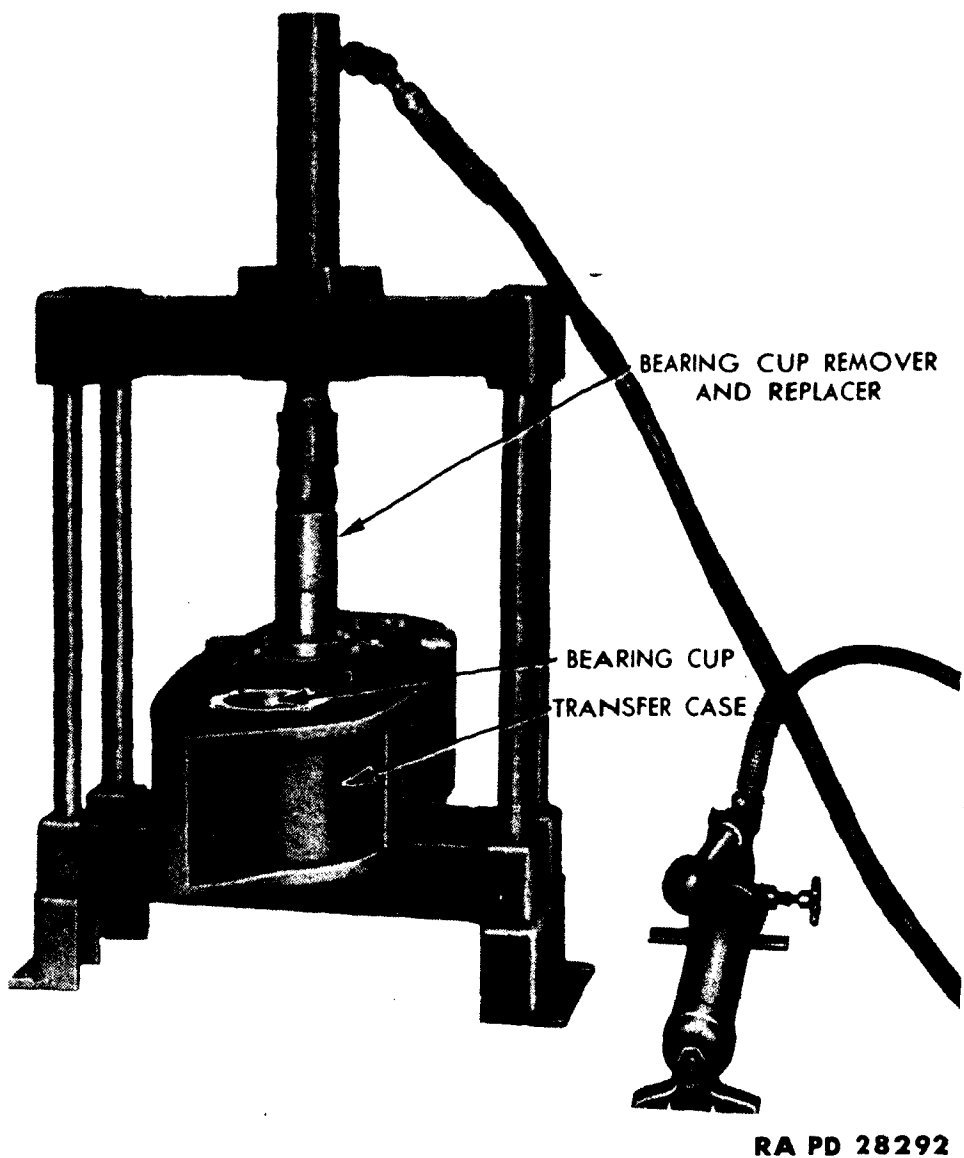
**Figure 41—Pressing Shifter Shaft Plug in Transfer Case Cover with Replacer 41-R-2395-150**

**37. REAR AXLE OUTPUT SHAFT ASSEMBLY.**

a. **Inspection.** Replace gears if excessively worn or if they have broken or chipped teeth. Twisted or worn shafts must be replaced. Gears or shafts with small nicks can be honed and then polished with a fine stone. Pitted, corroded, or discolored bearings, due to over-heating, must be replaced.

b. **Disassemble.** Place the rear axle output shaft in the press. Press the rear bearing cone, spacer, front and rear axle drive shaft

**ORDNANCE MAINTENANCE—POWER TRAIN, SUSPENSION, HULL  
AND TURRET FOR ARMORED CAR M8 AND UTILITY CAR M20**



**Figure 42—Pressing Bearing Cup from Transfer Case with Remover and Replacer 41-R-2385-115**

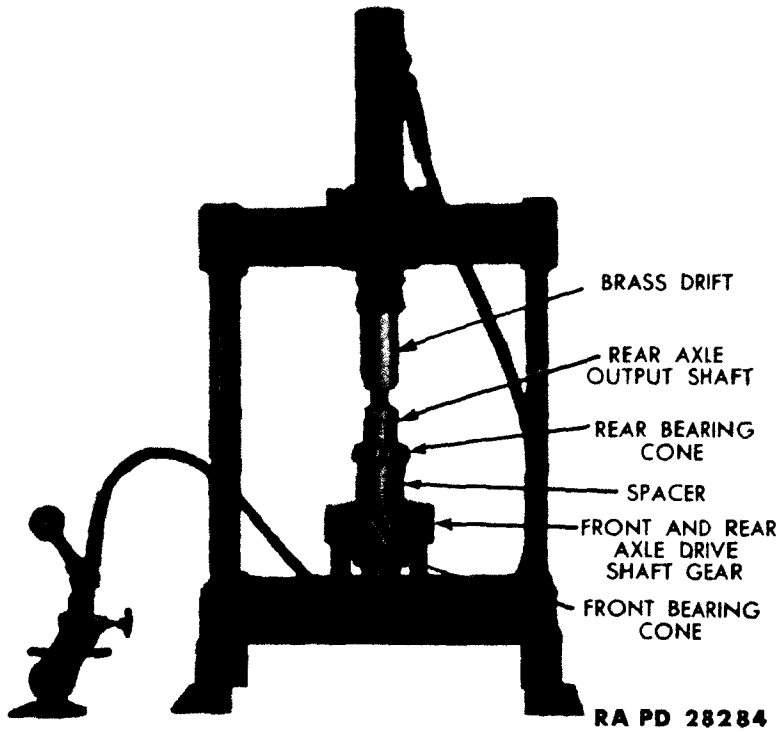
gear off the shaft (fig. 43). Reverse the position of the shaft in the press. Press the front bearing cone off the shaft.

**c. Assemble.** Press the front and rear axle drive shaft gear (29 teeth, left-hand helix), spacer, and rear bearing cone onto the rear axle output shaft. Press the other bearing cone onto the opposite end of the shaft.

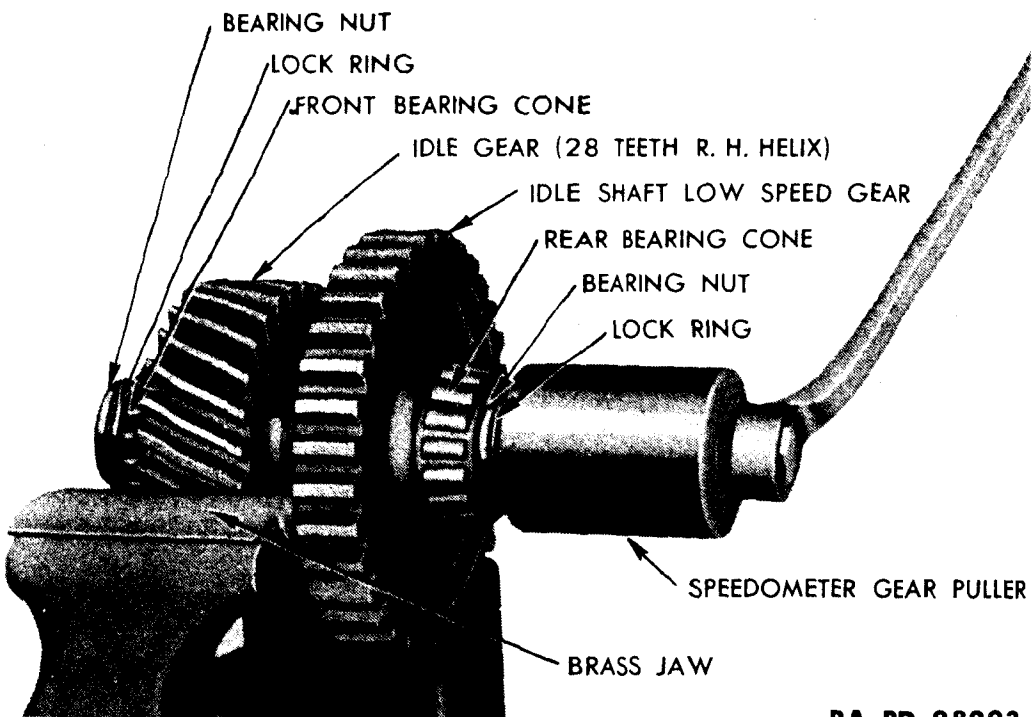
**38. IDLE SHAFT ASSEMBLY.**

**a. Inspection.** Replace the low speed gear or the helical gear if excessively worn, or if they have broken or chipped teeth. If the idle

**TRANSFER CASE CLEANING, INSPECTION AND REPAIR**

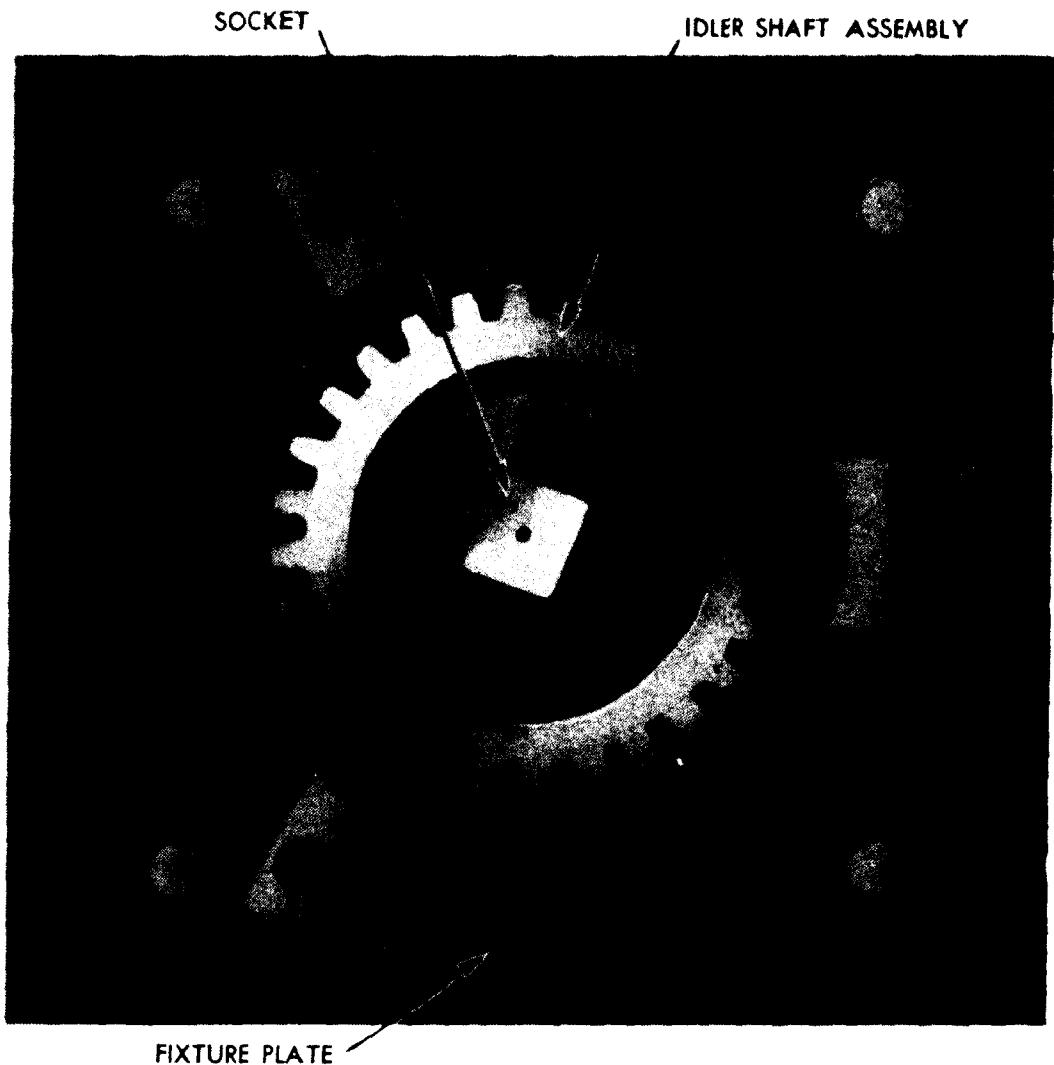


**Figure 43—Pressing Bearing Cone, Spacer, and Gear off Rear Axle Output Shaft**



**Figure 44—Removing Speedometer Gear from Idle Shaft with Puller**

**ORDNANCE MAINTENANCE—POWER TRAIN, SUSPENSION, HULL,  
AND TURRET FOR ARMORED CAR M8 AND UTILITY CAR M20**



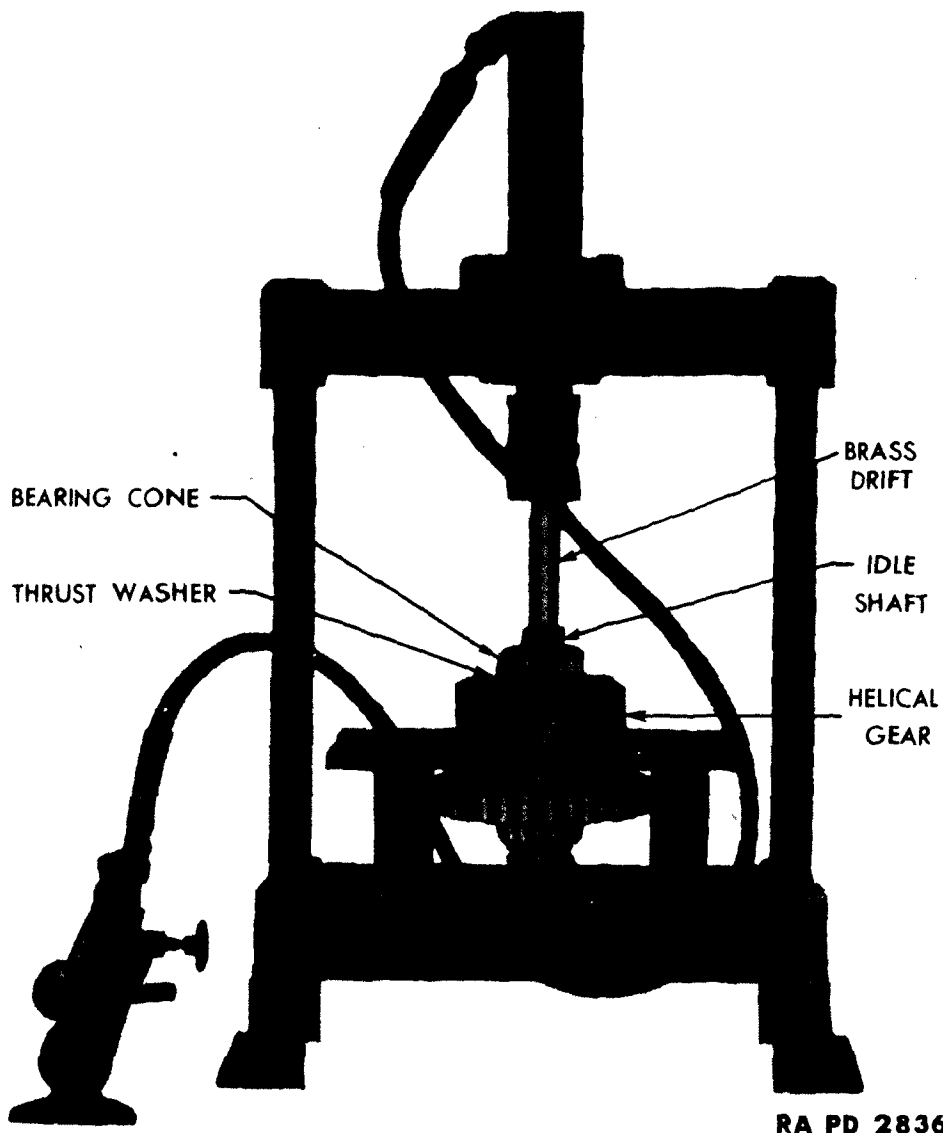
RA PD 317019

**Figure 45—Removing Idle Bearing Nut with Plate Assembly  
41-P-1522 and Socket Wrench**

shaft is twisted, worn, or has broken splines, it must be replaced. Pitted, corroded, or discolored bearings, due to overheating, must be replaced.

**b. Disassemble.** Pull the speedometer drive gear off the idle shaft with puller (MAS-6-145) (fig. 44). Remove the speedometer gear key. Pry the lock ring off each bearing nut with a small screwdriver. With the fixture plate (41-P-1522) and a socket wrench, remove the two bearing nuts, one at each end of the shaft. Place the idle shaft assembly in the press (fig. 46). Press the bearing cone, thrust washer, and

## TRANSFER CASE CLEANING, INSPECTION AND REPAIR



RA PD 28361

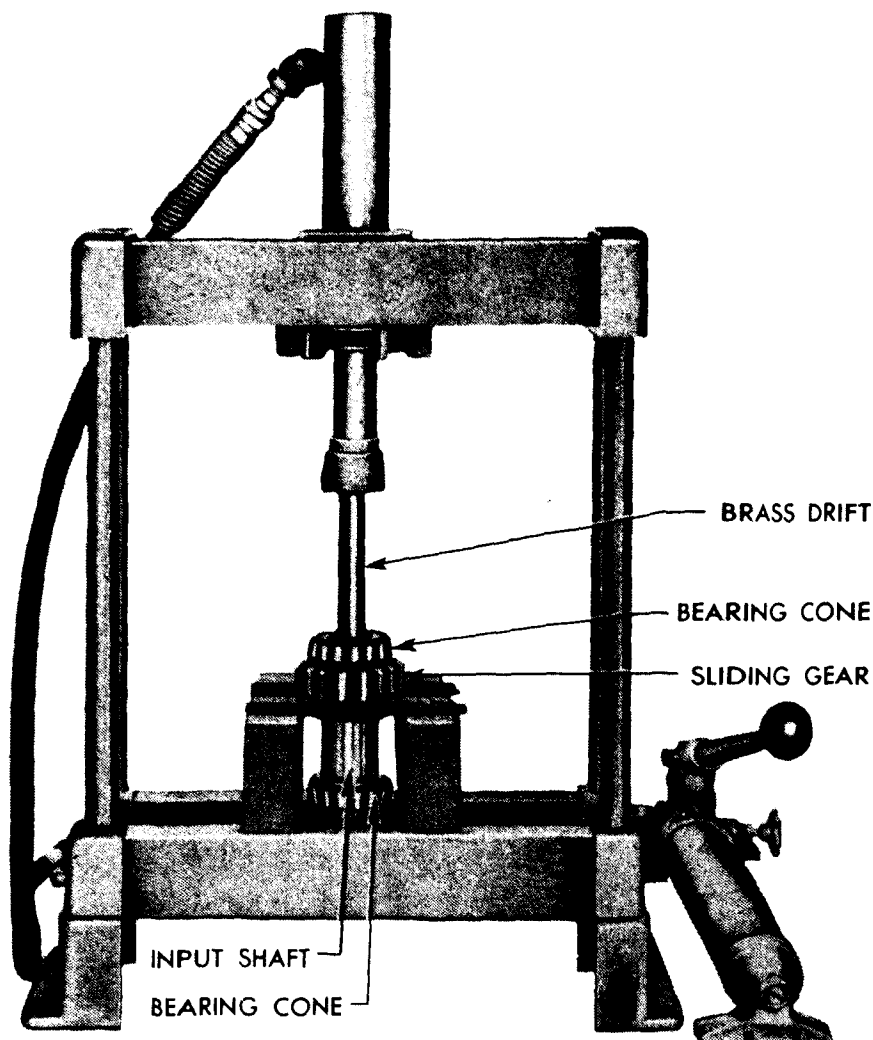
**Figure 46—Pressing Bearing Cone Thrust Washer and Helical Gear off the Idle Shaft**

the helical gear off the shaft. Reverse the position of the idle shaft in the press. Press low speed gear and bearing cone off the shaft.

c. **Assemble.** Press the low speed gear and bearing cone onto the rear end (end with speedometer gear seat) of the idle shaft. Press the helical gear (28 teeth, right-hand helix) thrust washer and bearing cone onto the front end of the idle shaft. Install a bearing nut on each end of the idle shaft. Place the idle shaft assembly in the fixture plate (41-P-1522), and tighten each bearing nut with socket wrench (41-W-2573-50) (fig. 45). Install a lock ring in the groove of each bearing nut, making sure the bent end of the lock ring is seated in the slot pro-



**ORDNANCE MAINTENANCE—POWER TRAIN, SUSPENSION, HULL,  
AND TURRET FOR ARMORED CAR M8 AND UTILITY CAR M20**



RA PD 28453

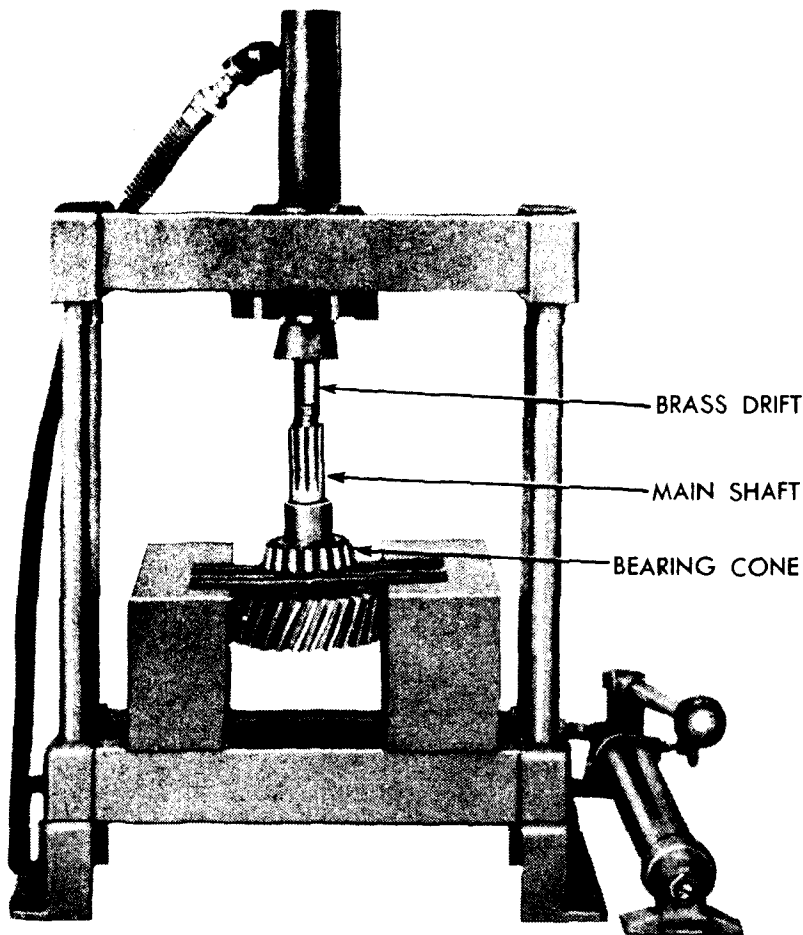
**Figure 47—Pressing Bearing Cone and Sliding Gear off Input Shaft**

vided in shaft. Inspect the speedometer gear for damage due to removing. Place the key in position on the idle shaft, and press the speedometer gear onto the shaft. Do not damage the gear teeth.

**39. INTERMEDIATE AXLE OUTPUT SHAFT ASSEMBLY.**

**a. Inspection.** Replace intermediate axle output shaft gear that has broken, chipped, or excessively worn teeth or splines. A twisted intermediate axle output shaft or a shaft with excessively worn or broken splines must be replaced. Gears or shafts with small nicks can be honed and then polished with a fine stone. Pitted, scored, or discolored bearings, due to overheating, must be replaced.

**TRANSFER CASE CLEANING, INSPECTION AND REPAIR**



RA PD 28452

**Figure 48—Pressing Bearing Cone off Main Drive Gear Shaft**

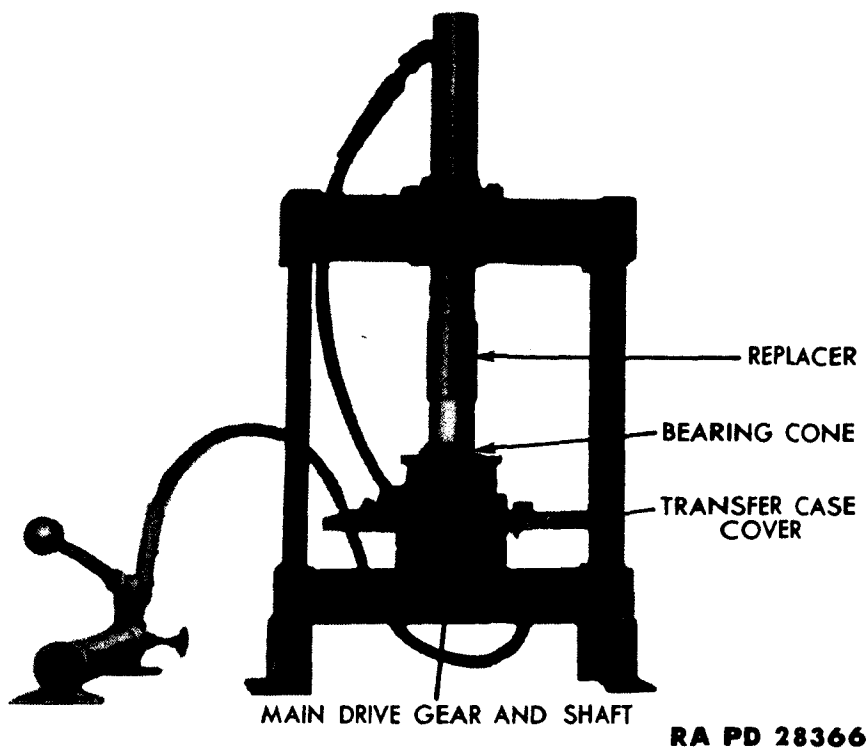
**b. Disassemble.** Pry the lock ring off the bearing nut with a small screwdriver. Remove the bearing nut with the fixture plate (41-P-1522). Place the shaft in a press. Press the intermediate axle output shaft gear and bearing cone off the shaft. Reverse the position of the shaft in the press. Press the other bearing cone off the shaft.

**c. Assemble.** Press the intermediate axle output shaft gear (29 teeth, right-hand helix) and bearing cone onto the front of the intermediate axle shaft. Press the other bearing cone on the rear end of the shaft. Install the bearing nut on the front end of the shaft. Place the output shaft assembly in the fixture plate (41-P-1522) and tighten the bearing nut with socket wrench (41-W-2573-50) (fig. 45). Install the lock ring in the groove of the bearing nut, making sure the bent end of the lock ring is seated in the slot provided in the shaft.

**40. INPUT SHAFT ASSEMBLY.**

**a. Inspection.** The input shaft and input shaft gear are matched,

**ORDNANCE MAINTENANCE—POWER TRAIN, SUSPENSION, HULL,  
AND TURRET FOR ARMORED CAR M8 AND UTILITY CAR M20**



**Figure 49—Pressing Bearing Cone on Main Drive Gear Shaft  
with Replacer 41-R-2395-9**

therefore, if one unit of the set is unserviceable, both gear and shaft must be replaced. An input shaft that has broken, chipped, or excessively worn teeth must be replaced. A twisted input shaft or a shaft with broken splines must be replaced. A gear or shaft with small nicks can be honed and then polished with a fine stone. Slide the input shaft gear on the shaft. A gear and shaft that has in excess of 0.006-inch backlash must be replaced.

**b. Disassemble.** Place the input shaft assembly in the press (fig. 47). Press the bearing cone and input shaft gear off the shaft. Reverse the position of the shaft in the press. Press the other bearing cone off the shaft.

**c. Assemble.** Press the small bearing cone onto the rear end of the input shaft. Slide the input shaft gear onto the input shaft with the shifter fork channel toward the threaded end of the shaft. Press the other bearing cone onto the front end of the shaft.

#### **41. MAIN DRIVE GEAR AND SHAFT.**

**a. Inspection.** Replace gears with broken, chipped or excessively worn teeth and splines. Small nicks will be honed and then polished

**TRANSFER CASE CLEANING, INSPECTION AND REPAIR**

with a fine stone. Replace pitted, scored, or discolored bearing cone or cup.

**b. Disassemble.** Pry the bearing cone off the shaft far enough to place it in the press. Place the main drive gear shaft assembly in a press (fig. 48). Press the bearing cone off the shaft.

**c. Assemble.** Press the bearing cone on the shaft with bearing replacer (41-R-2395-9), with the large end of bearing cone toward the gear end of shaft.

**42. SHIFT MECHANISM.**

**a.** Replace scored, worn, or bent shifter shafts. Interlocking balls with flat spots must be replaced. Broken or weak interlocking ball springs must be replaced. Broken or damaged shifter forks must be replaced.

**ORDNANCE MAINTENANCE—POWER TRAIN, SUSPENSION, HULL,  
AND TURRET FOR ARMORED CAR M8 AND UTILITY CAR M20**

**CHAPTER 4**

**TRANSFER CASE (Cont'd)**

**Section IV**

**ASSEMBLY OF TRANSFER CASE**

	<b>Paragraph</b>
Fitting front axle declutch shaft assembly in bearing carrier . . . . .	43
Fitting rear axle output shaft assembly in case . . . . .	44
Fitting idle shaft assembly in case . . . . .	45
Fitting intermediate axle output shaft assembly in case . . . . .	46
Fitting main drive gear in cover and bearing carrier . . . . .	47
Fitting input shaft assembly in case . . . . .	48
Installation of gear and shaft assemblies in transfer case . . . . .	49
Final assembly . . . . .	50

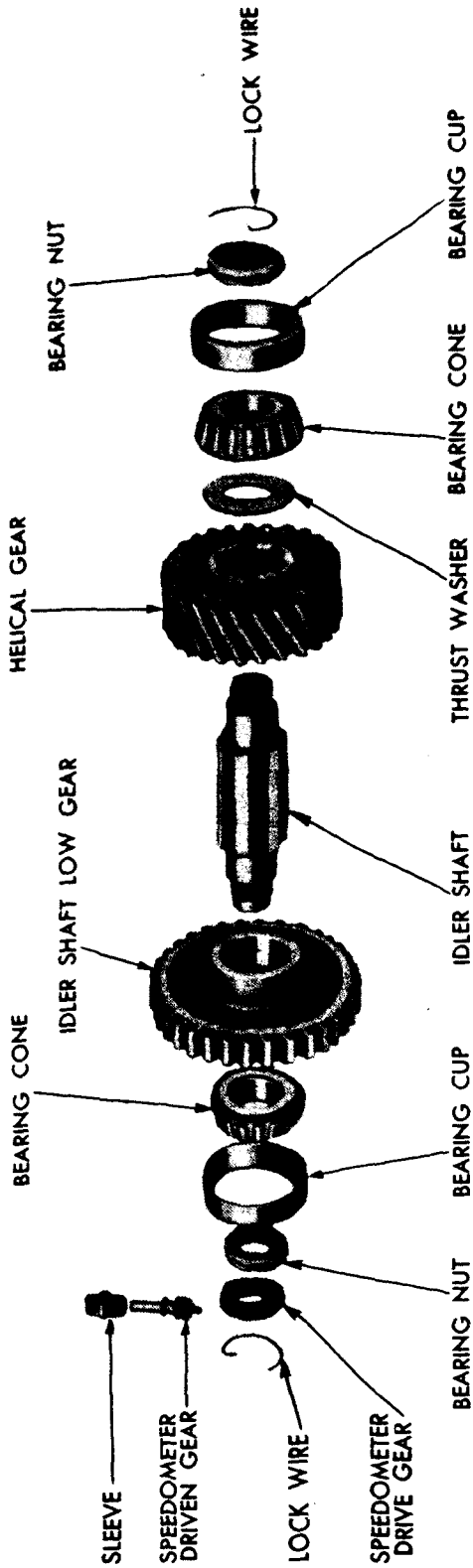
**43. FITTING FRONT AXLE DECLUTCH SHAFT ASSEMBLY  
IN BEARING CARRIER.**

**a. Install Shifter Fork.** Place the shifter fork in the bearing cage. Slide the shift rail into the bearing carrier and through the shifter fork. Install the shifter fork lock screw in the shifter fork, making sure the lock screw is seated in the front notch from the rear of the shift rail. Drop the declutch shift rail interlocking ball and spring into the pocket, located directly in front of the filler plug hole. Install the interlocking ball spring seat plate.

**b. Install Front Axle Declutch Shaft Assembly in Bearing Carrier.** Hold the front axle declutch sleeve in position (short end of sleeve toward front) in bearing carrier, and slide the front axle declutch shaft assembly into the front end of the bearing carrier, and through front axle declutch sleeve. Press the bearing cup  $\frac{3}{4}$  of the way into the bearing carrier.

**c. Fit Front Axle Declutch Shaft Assembly in Bearing Carrier.** Install the front axle declutch bearing cap, shims and gasket on the bearing carrier. Tighten the four cap screws evenly to prevent cracking the bearing cap. Shims are to be added or removed until the shaft has no end play, but turns freely. When adjusting bearings, each time shims are added, the shaft must be free before attempting to tighten the bearing cap again. Always use the same gasket that will be used in the final assembling.

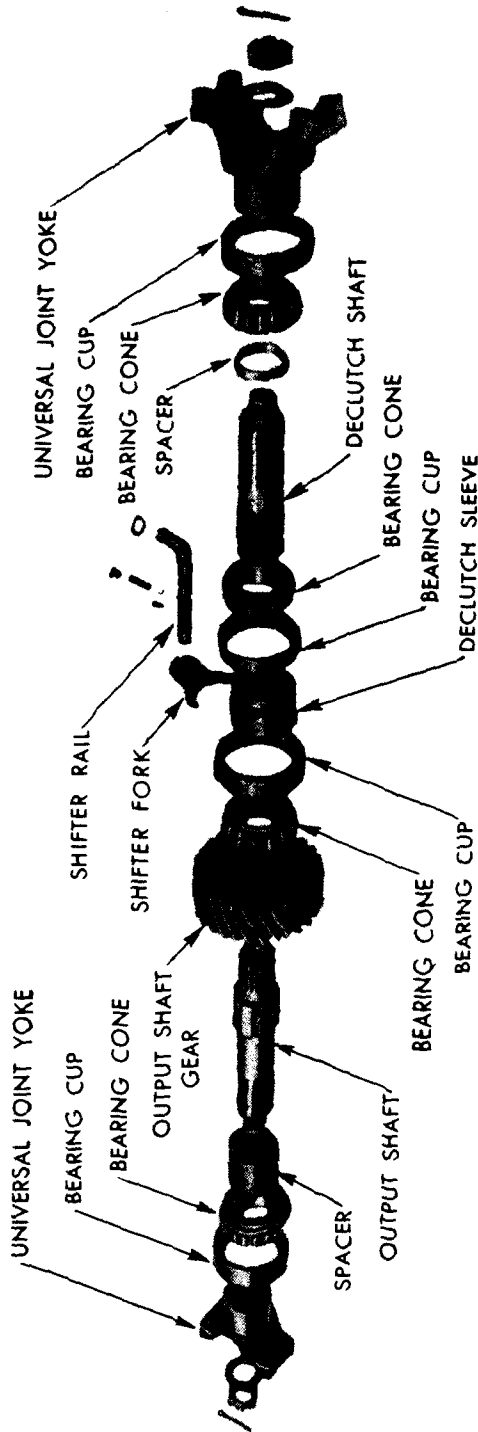
ASSEMBLY OF TRANSFER CASE



RA PD 28364

Figure 50—Idle Shaft Disassembled

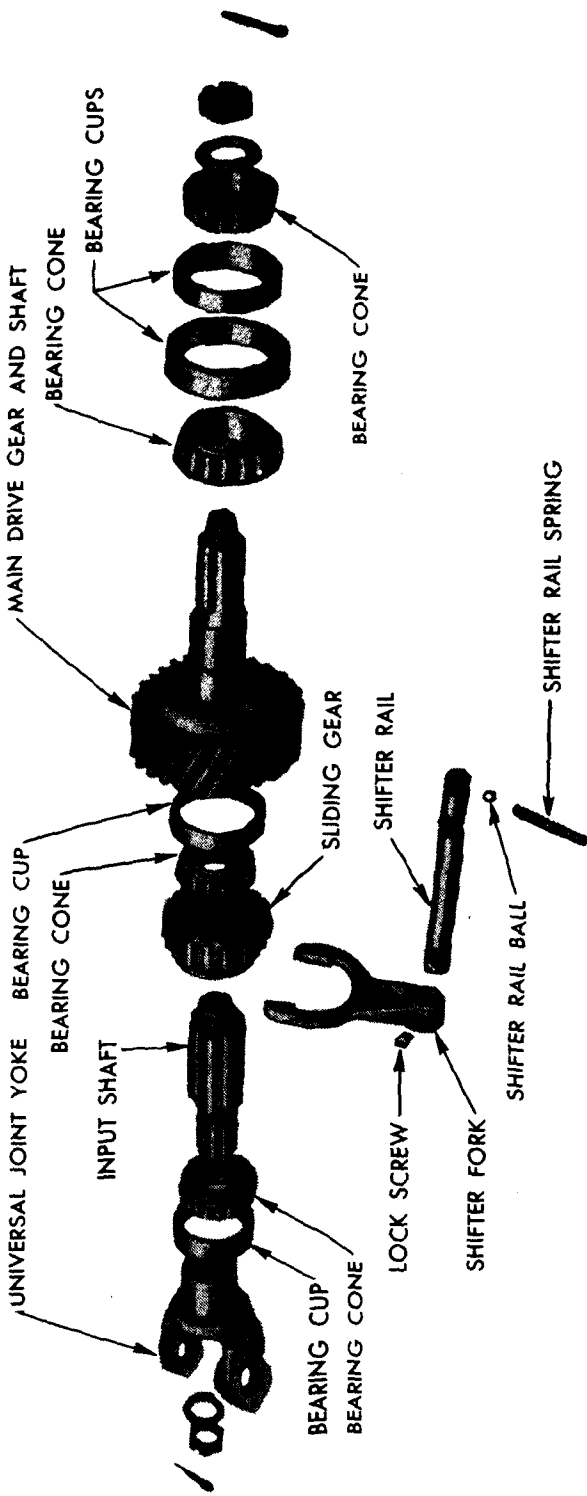
ORDNANCE MAINTENANCE—POWER TRAIN, SUSPENSION, HULL,  
AND TURRET FOR ARMORED CAR M8 AND UTILITY CAR M20



RA PD 28365

Figure 51—Rear Axle Output Shaft and Front Axle Declutch Shaft, Disassembled

ASSEMBLY OF TRANSFER CASE



RA PD 317012

Figure 52—Input Shaft and Main Drive Gear Shaft, Disassembled



**ORDNANCE MAINTENANCE—POWER TRAIN, SUSPENSION, HULL,  
AND TURRET FOR ARMORED CAR M8 AND UTILITY CAR M20**

**44. FITTING REAR AXLE OUTPUT SHAFT ASSEMBLY IN  
CASE.**

a. **Install Front Axle Declutch Bearing Carrier Assembly on Transfer Case Cover.** In fitting all gears in case, dowels must be in the cover to aline the case and cover. Install a gasket, front axle declutch bearing carrier assembly, and six cap screws on the transfer case cover.

b. **Install Rear Axle Output Shaft Assembly in Case.** Place the rear axle output shaft in the case with the spacer toward the rear of the case. Lay the transfer case cover and bearing carrier assembly on the case and install four cap screws in the cover. Install the rear axle output shaft bearing cap, shims and gasket. Tighten the four bearing cap screws evenly to prevent cracking the bearing cap. Make sure the front axle shift rail is disengaged. Shims are to be added or removed until the shaft has 0.003-inch to 0.005-inch end play. When adjusting bearings, each time shims are added, the shaft must be free before attempting to tighten the bearing cap again. Always use the same gasket that is to be used in the final assembling.

c. **Remove Rear Axle Output Shaft from Case.** Remove the four cap screws that hold the cover to the case and lift off the cover. Lift out the rear axle output shaft.

**45. FITTING IDLE SHAFT ASSEMBLY IN CASE.**

a. **Install Idle Shaft Assembly in Case.** Place the idle shaft assembly in the case. Install the gasket and transfer case cover on the case and tighten the cover down with four cap screws.

b. **Adjust Idle Shaft in Case.** Install the front bearing cover, shims and gasket. Tighten the four bearing cover cap screws evenly to prevent cracking the cover. Install the rear bearing cover, shims and gasket on the case. Reach in the case through the main drive gear opening and turn the idle shaft by hand. Shims must be added or removed until the shaft has 0.003-inch to 0.005-inch end play. Always use the same gaskets that are to be used in the final assembly when adjusting bearings.

c. **Remove Idle Shaft Assembly from Case.** Remove the four cap screws that hold the transfer case cover to the case and lift off the cover. Lift the idler shaft assembly from the case.

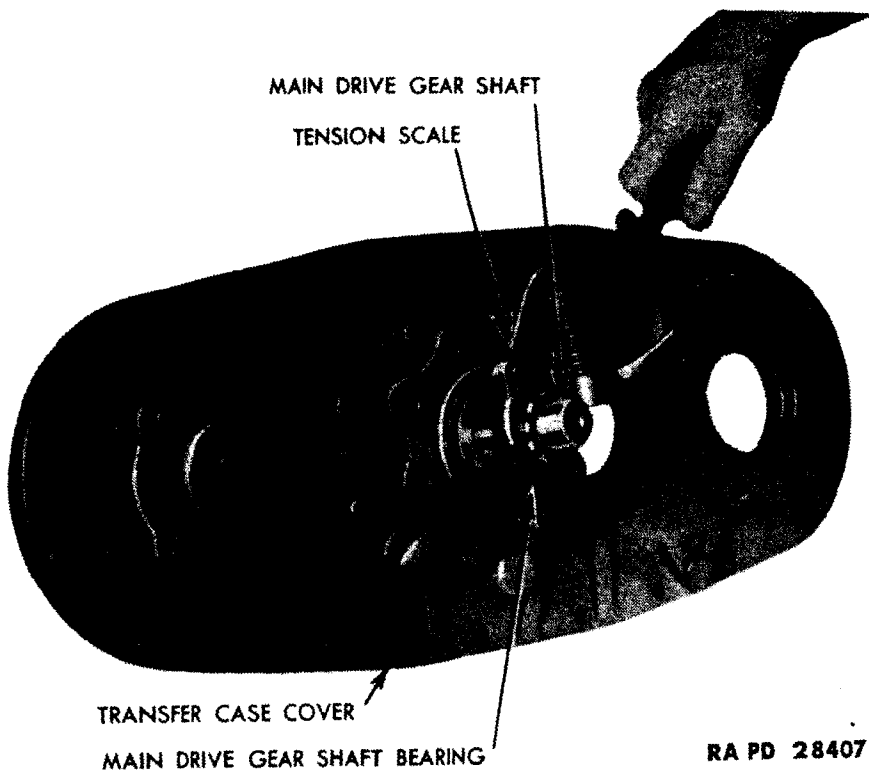
**46. FITTING INTERMEDIATE AXLE OUTPUT SHAFT  
ASSEMBLY IN CASE.**

a. **Install Intermediate Axle Output Shaft Assembly in Case.**

### ASSEMBLY OF TRANSFER CASE

Place the intermediate axle output shaft assembly in the case. Install a gasket and transfer case cover on the case and tighten the cover down with four cap screws.

b. **Fit Intermediate Axle Output Shaft Assembly in Case.** Install the front bearing cover, shims and gasket on the transfer case cover. Tighten the four cover cap screws evenly to prevent cracking the cover. Install the rear bearing cap, shims and gasket. Shims must be added or removed until the shaft has 0.003-inch to 0.005-inch end play. Always use the same gaskets that are to be used in the final assembling. Remove the four cap screws from the transfer case cover and lift off the cover.



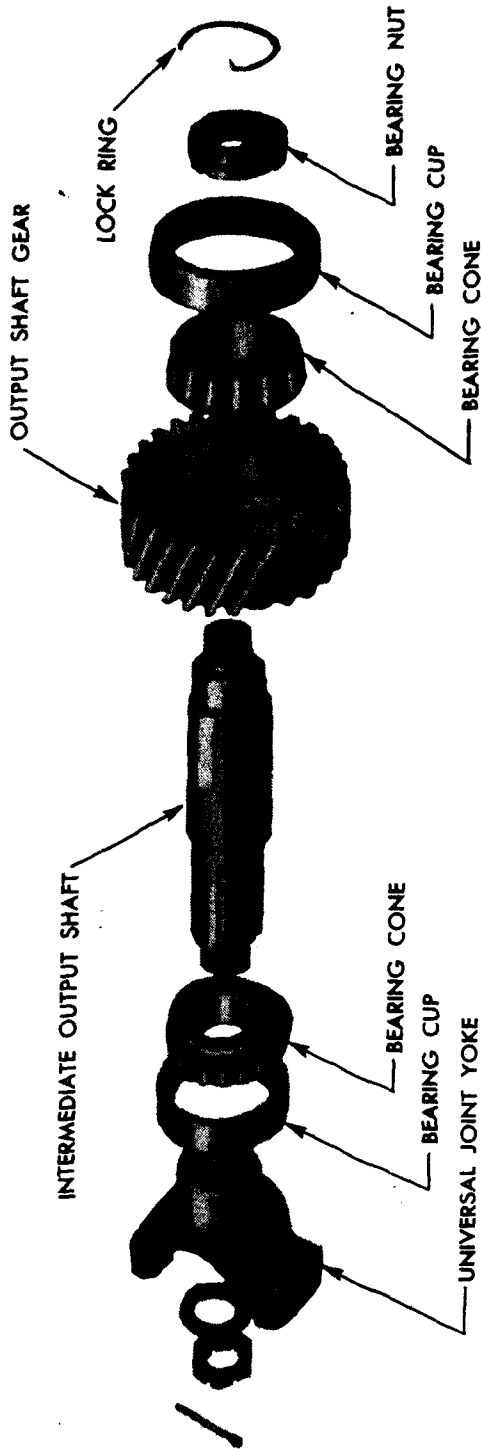
**Figure 53—Checking Preload on Main Drive Gear Shaft Bearings with Tension Scale 41-S-495**

#### 47. FITTING MAIN DRIVE GEAR IN COVER AND BEARING CARRIER.

a. **Install Main Drive Gear Bearing Carrier on Cover.** Install a gasket, bearing carrier and six cap screws on the transfer case cover.

b. **Install and Fit Main Drive Gear in Cover and Bearing Carrier.** Place the same shims that were removed in disassembly on the main drive gear and shaft. Place the main drive gear, cover and

ORDNANCE MAINTENANCE—POWER TRAIN, SUSPENSION, HULL,  
AND TURRET FOR ARMORED CAR M8 AND UTILITY CAR M20



RA PD 28363

Figure 54—Intermediate Axle Output Shaft, Disassembled

### ASSEMBLY OF TRANSFER CASE

bearing carrier in the press (fig. 49). Press the front main drive gear bearing cone onto the shaft with bearing cone replacer (41-R-2395-9). Lift the assembly from the press. Turn the main drive gear shaft with the tension scale (41-S-495) (fig. 53), if the reading is lower than six inch-pounds, shims must be removed. If the reading is over 10 inch-pounds, more shims must be added.

#### 48. FITTING INPUT SHAFT ASSEMBLY IN CASE.

a. **Install Input Shaft in Case.** Place the input shaft assembly in the case. Install gasket, cover and main drive gear. Tighten the transfer case cover down with four cap screws.

b. **Fit Input Shaft Assembly in Case.** Install the input shaft bearing cap, shims, and gasket on the case. Tighten the four bearing cap screws evenly to prevent cracking the bearing cap. Make sure the input shaft gear is disengaged from the main drive gear. Shims are to be added or removed until the shaft has no end play but turns freely. Always use the same gaskets that are to be used in the final assembling.

#### 49. INSTALLATION OF GEAR AND SHAFT ASSEMBLIES IN TRANSFER CASE.

a. Place the idle shaft assembly in the case with the speedometer gear toward the rear of the case. Place the rear axle output shaft assembly in the case with the front and rear axle drive gear toward the front of the case.

#### 50. FINAL ASSEMBLY.

a. **Install Shifter Fork in Case.** Hold the shifter fork in the channel of the input shaft gear. Slide the shift rail into the case and through the shifter fork. Install the shifter fork lock screw, making sure it is seated in the shift rail. Install lock wire in the shifter shaft lock screw. Install the shift rail interlocking ball and spring. Install a gasket, shifter shaft cover and four cap screws. Make sure the dowels are in place and install gasket and the transfer case cover on the case. Install and tighten the 20 transfer case cover cap screws.

b. **Install Hand Brake Anchor Bracket and Hand Brake Band.**

(1) **HAND BRAKE ANCHOR BRACKET.** Place the hand brake anchor bracket on the main drive gear bearing carrier and install the four cap screws and dowels.

(2) **HAND BRAKE DRUM AND BRAKE BAND** (fig. 33). Slide the hand brake drum drive flange on the main drive gear shaft. Install a

**ORDNANCE MAINTENANCE—POWER TRAIN, SUSPENSION, HULL,  
AND TURRET FOR ARMORED CAR M8 AND UTILITY CAR M20**

castellated nut and cotter pin on the main drive gear shaft. Install the four splined bolts through the drive flange and hand brake drum and install the four lock washers and nuts. Compress the anchor bracket expansion spring in the hand brake anchor bracket and slide the hand brake band on the bracket and brake drum. Install the anchor bracket adjusting screw and tighten it until there is 0.020 inch clearance between the brake band and the drum. Install lock wire in the anchor bracket adjusting screw. Install the anchor bolt, lock washer, and jam nut in the brake band and anchor bracket. Tighten the anchor bolt until 0.020-inch clearance is established between the lower half of the brake band and drum. Tighten the jam nut on the anchor bolt. Install the upper and lower expansion spring between the anchor bracket and the brake band. Install a spacer on the adjustment bolt, and install it in the brake band. Install the other spacer, adjusting nut, lock washer, and jam nut on the adjusting screw. Tighten the adjusting nut until 0.020-inch clearance is established between the upper half of the brake band and drum. Slide the clevis pin through the torque rod connecting links, operating cam, and adjusting screw. Install a cotter pin in the clevis pin. Fill transfer case to proper level with approved lubricant.

**CHAPTER 5**  
**REAR AND INTERMEDIATE AXLES**

**Section I**

**DESCRIPTION AND DATA**

	<b>Paragraph</b>
Description .....	51
Data .....	52

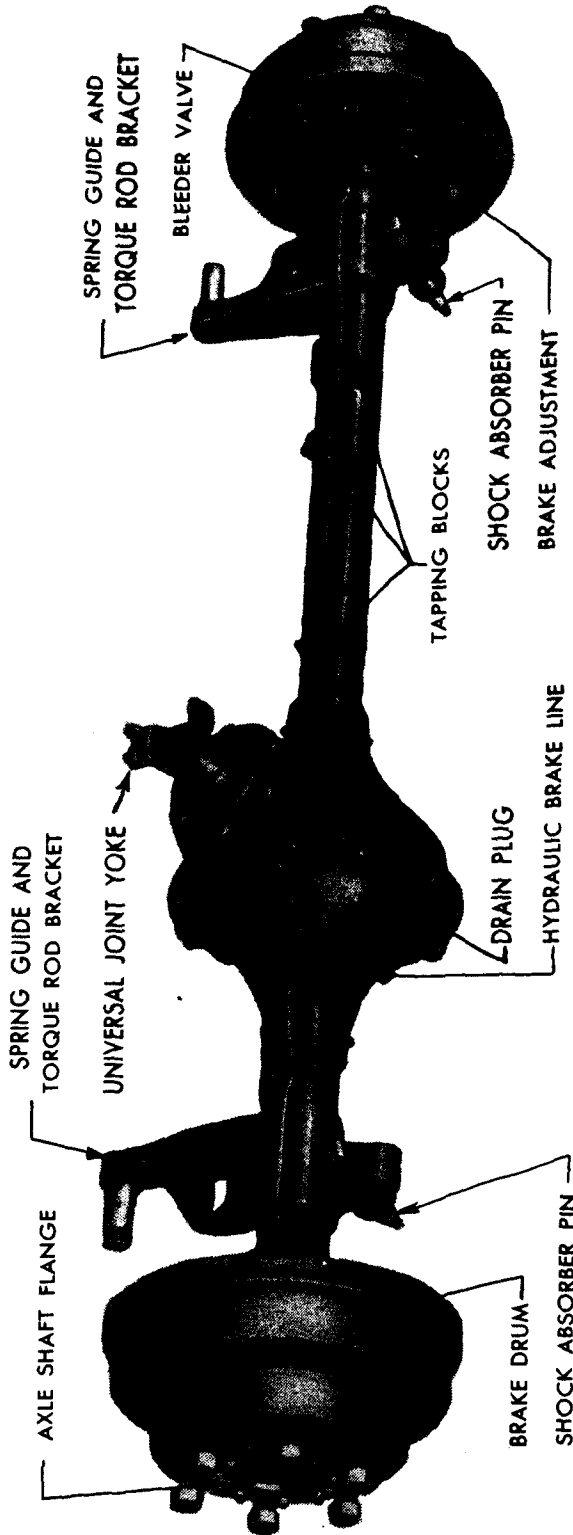
**51. DESCRIPTION.**

a. The rear and intermediate axles are of special design following the general construction of standard Ford truck axles with spiral bevel drive gears and a straddle-mounted pinion. Figures 55 and 56 show the complete axle assemblies ready to be installed to the bogie assembly.

**52. DATA.**

Ratio .....	6.66 to 1
Type .....	Full floating
Made by .....	Ford Motor Company
Model .....	GAK

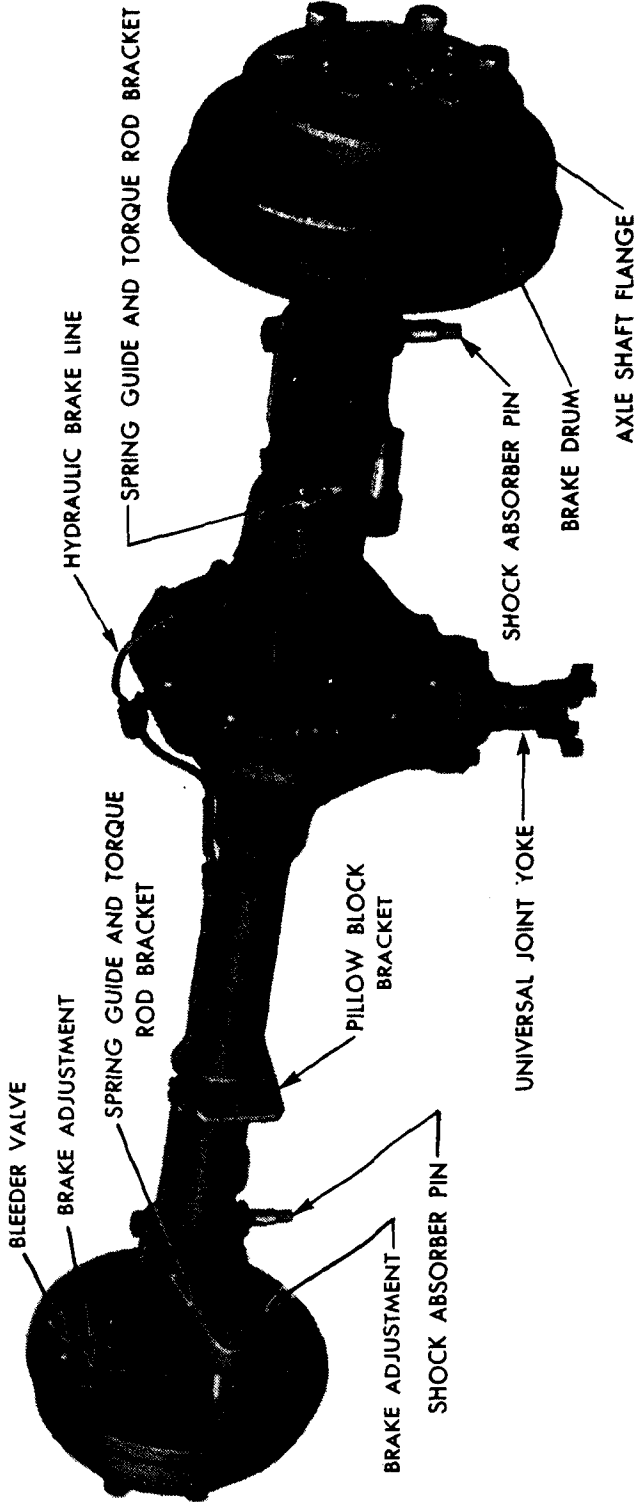
ORDNANCE MAINTENANCE—POWER TRAIN, SUSPENSION, HULL,  
AND TURRET FOR ARMORED CAR M8 AND UTILITY CAR M20



RA PD 28409

Figure 55—Rear Axle Assembly

DESCRIPTION AND DATA



RA PD 28408

Figure 56—Intermediate Axle Assembly



**ORDNANCE MAINTENANCE—POWER TRAIN, SUSPENSION, HULL,  
AND TURRET FOR ARMORED CAR M8 AND UTILITY CAR M20**

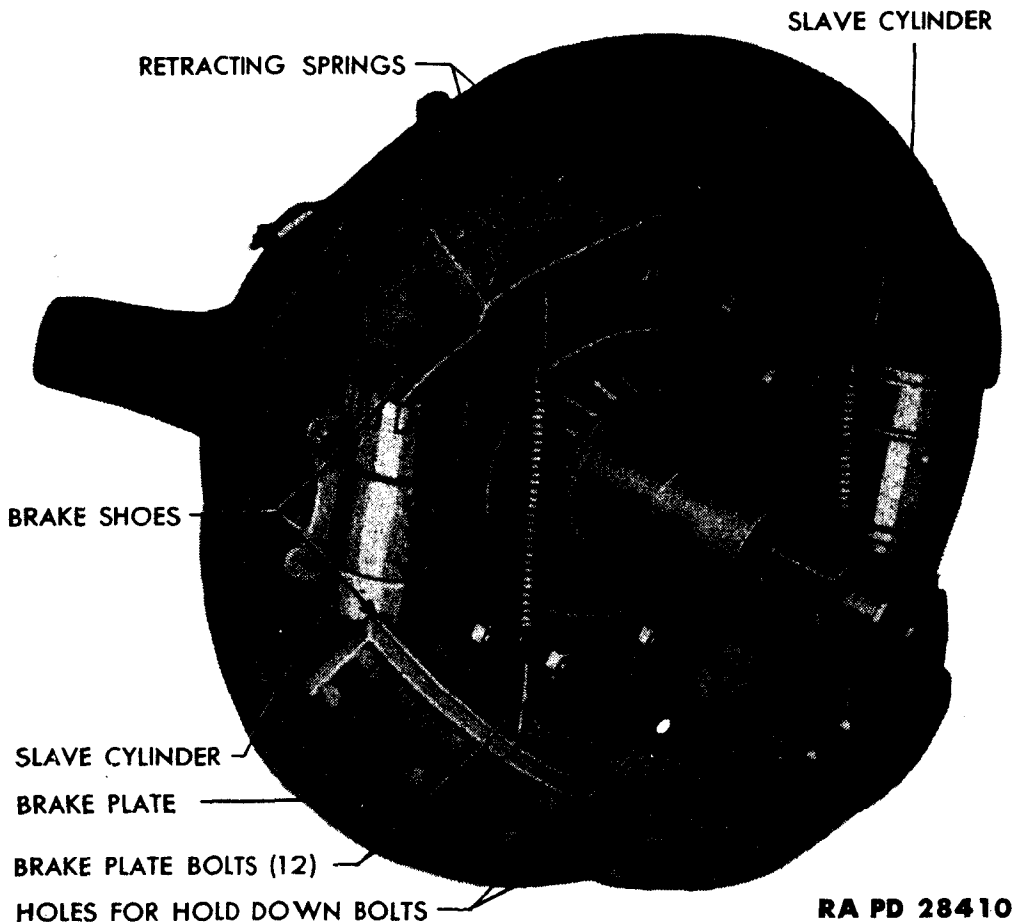
**CHAPTER 5**

**REAR AND INTERMEDIATE AXLES (Cont'd)**

**Section II**

**DISASSEMBLY OF REAR OR INTERMEDIATE AXLE**

	Paragraph
Preliminary work .....	53
Removal of differential .....	54
Removal of drive pinion assembly from axle housing .....	55
Removal of drive pinion gear shaft from sleeve .....	56
Disassembly of differential .....	57



**Figure 57—Removing Brake Shoes**

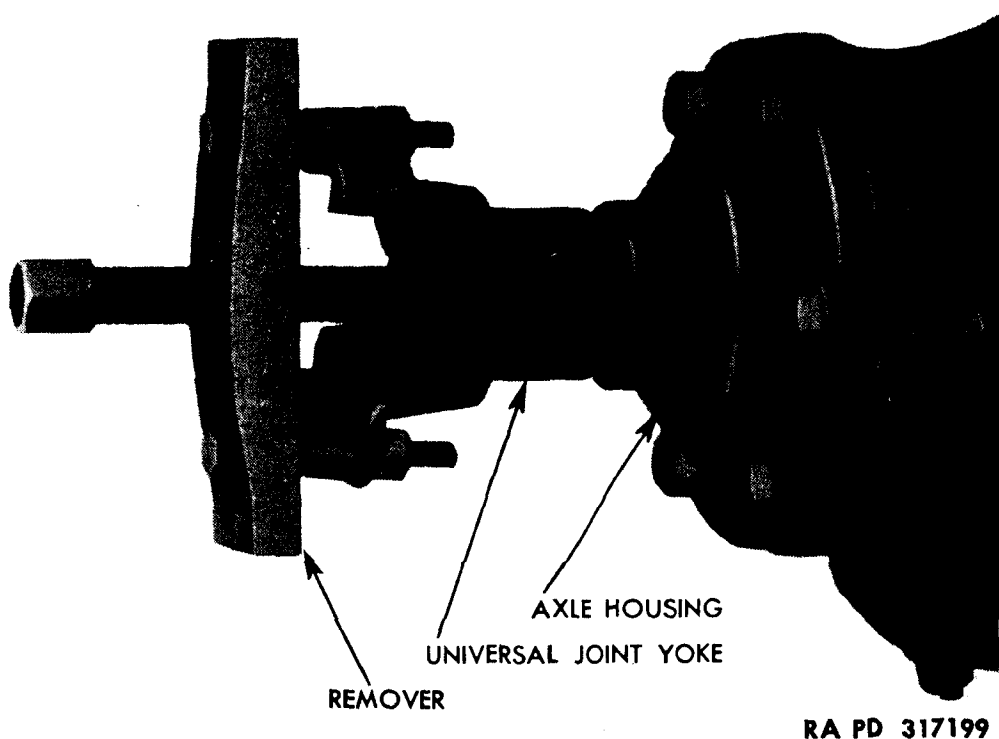
**53. PRELIMINARY WORK.**

**a. Remove Hydraulic Brake Lines.** Remove the brake line guard clamps and guards. Disconnect the hydraulic line at the junction

### DISASSEMBLY OF REAR OR INTERMEDIATE AXLE

block on each brake plate. Remove the brake line hold-down clamps and lift the hydraulic line from the housing.

b. **Remove Hub and Brake Drum Assemblies.** Remove the eight equally spaced nuts, lock washers, and centering wedges from the axle shaft. Tighten the two remaining cap screws on the axle shaft to force it part way off the hub. Pull the axle shaft the rest of the way out of the axle housing. Straighten the tab on the lock washer, remove the wheel bearing nut, and pull the hub and brake drum assemblies from the axle housing.



**Figure 58—Removing Universal Joint Yoke with Remover 41-R-2384-82**

c. **Remove Brake Plates.** Remove the two hold-down bolts from each brake shoe and lift off the shoes (fig 57). Remove the 12 bolts that hold the brake plate to the axle housing. Tap the brake plate assembly off the axle housing with a brass hammer.

### 54. REMOVAL OF DIFFERENTIAL.

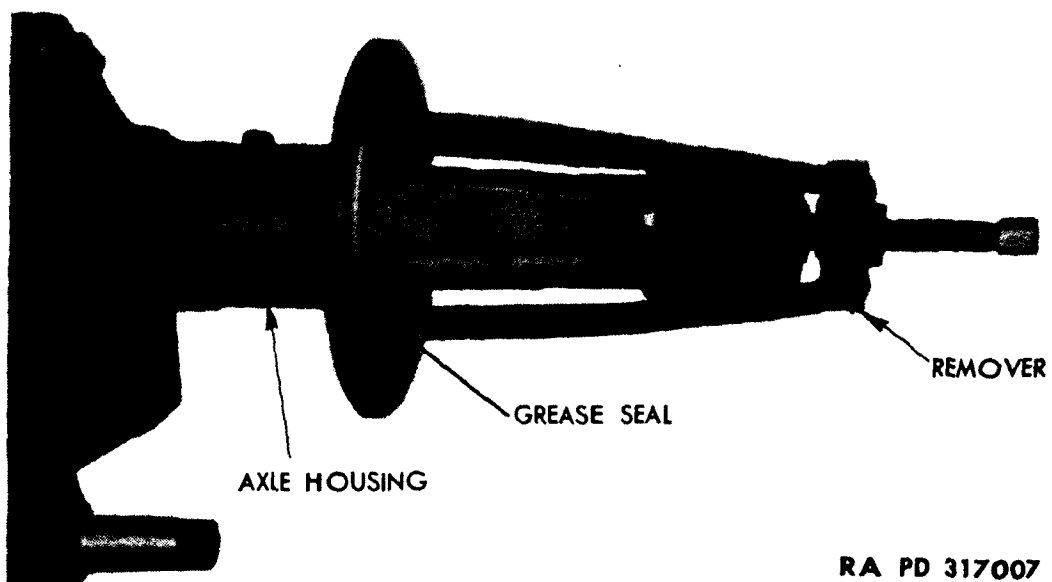
a. Remove the drain plug and drain the axle. Remove the 13 bolts and cap screws that hold the axle housings together. Lift the differential from the housings.

**ORDNANCE MAINTENANCE—POWER TRAIN, SUSPENSION, HULL,  
AND TURRET FOR ARMORED CAR M8 AND UTILITY CAR M20**

**55. REMOVAL OF DRIVE PINION ASSEMBLY FROM AXLE  
HOUSING.**

**a. Remove Universal Joint Yoke.** Remove the cotter pin and castellated nut that hold the universal joint yoke to the pinion gear shaft. Pull the universal joint yoke off the shaft with remover (41-R-2384-82) (fig. 58).

**b. Remove Pinion Gear and Shaft Assembly.** Remove the six cap screws that hold the pinion gear and shaft assembly in the differential housing. Tap on the end of the pinion gear shaft from



RA PD 317007

**Figure 59—Removing Hub Inner Bearing Grease Seal from Axle  
Housing with Remover 41-R-2381-350**

inside the housing with a brass hammer and drive the assembly from the housing.

**56. REMOVAL OF DRIVE PINION GEAR SHAFT FROM  
SLEEVE.**

**a. Straighten the tab on the lock washer.** Remove the lock nut, lock washer and adjustment nut with the two pinion lock nut adjusting wrenches (41-W-1470-100) (fig. 72), and slide the drive pinion from the sleeve. Lift the front bearing cone and sleeve off the pinion gear shaft.

**DISASSEMBLY OF REAR OR INTERMEDIATE AXLE****57. DISASSEMBLY OF DIFFERENTIAL.**

a. Remove the lock wire and eight differential cap screws from the differential housing. Tap the left-hand differential case off the ring gear case with a brass hammer. Lift out the spider, spider gears, and spider gear thrust washers. Slide the axle shaft gear and thrust washer from the (right- and left-hand) differential case.

**ORDNANCE MAINTENANCE—POWER TRAIN, SUSPENSION, HULL,  
AND TURRET FOR ARMORED CAR M8 AND UTILITY CAR M20**

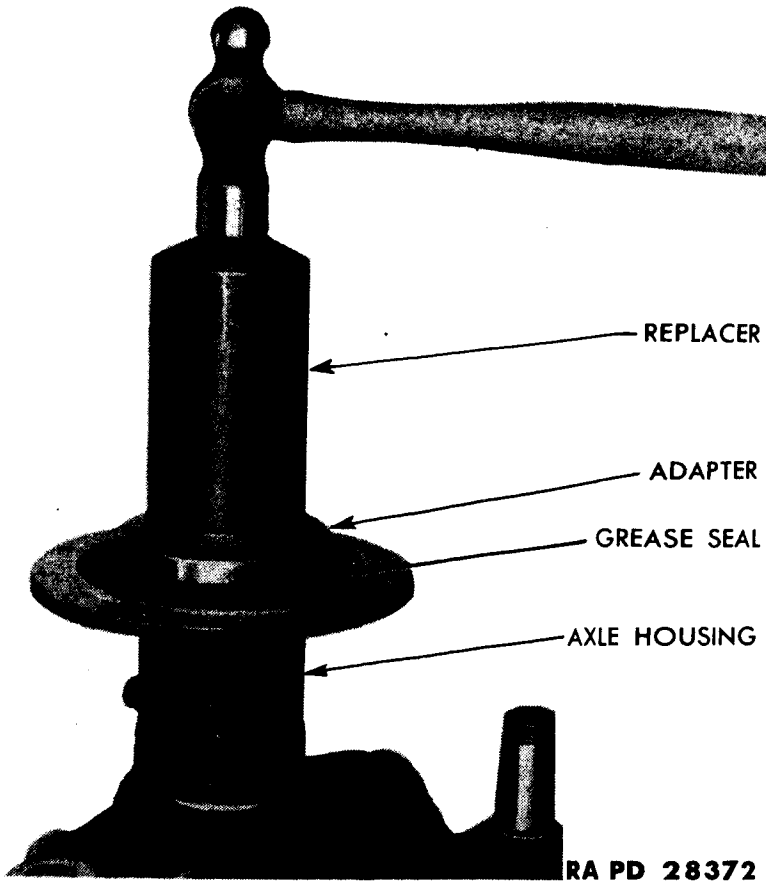
**CHAPTER 5**

**REAR AND INTERMEDIATE AXLES (Cont'd)**

**Section III**

**REAR AND INTERMEDIATE AXLE CLEANING,  
INSPECTION AND REPAIR**

	Paragraph
Cleaning .....	58
Axle housing .....	59
Pinion gear sleeve .....	60
Axle shafts .....	61
Ring gear and pinion .....	62
Spider and spider gears .....	63
Axle shaft drive gears .....	64



**Figure 60—Driving Hub Inner Bearing Grease Seal on Axle Housing  
with Replacer 41-R-2394-130 and Adapter**

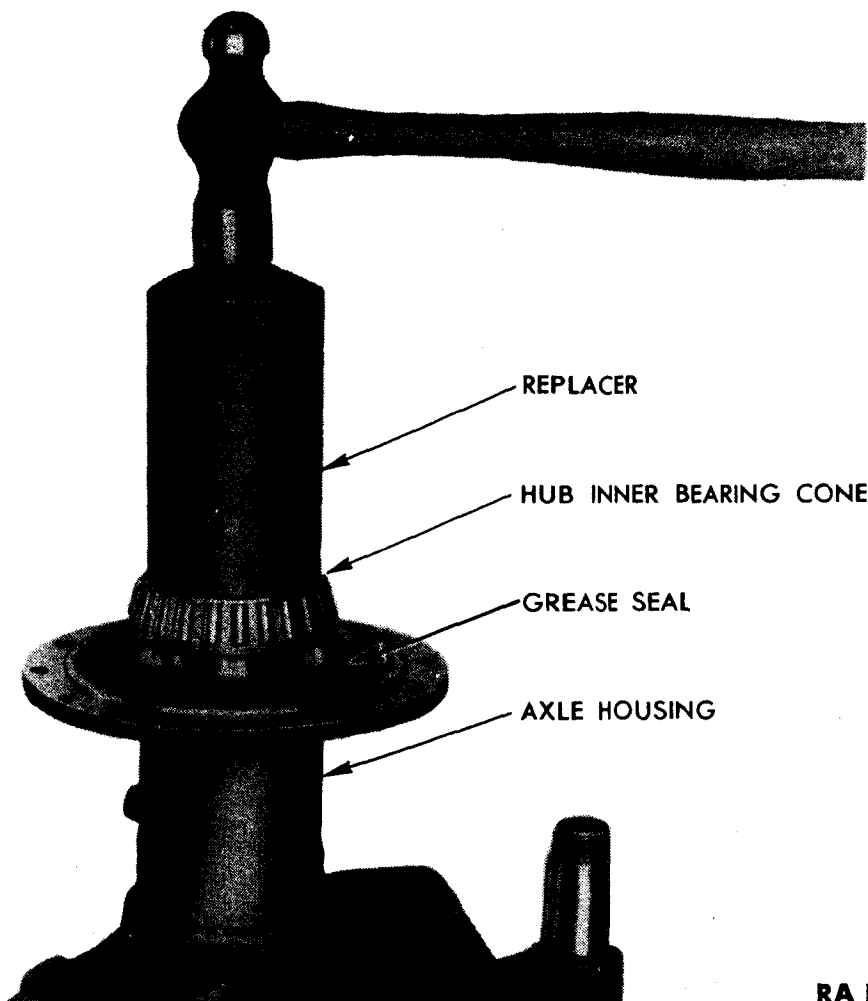
## REAR AND INTERMEDIATE AXLE CLEANING, INSPECTION AND REPAIR

### 58. CLEANING.

a. Wash all parts thoroughly in dry-cleaning solvent. Rotate the bearings while immersed in clean dry-cleaning solvent until all trace of old lubricant has been removed. Oil the bearings immediately after cleaning to prevent corrosion of highly polished surfaces.

### 59. AXLE HOUSING.

a. **Inspection.** Axle housings with broken welds, missing tapping blocks (fig. 55) broken, missing or loose rivets, damaged threads, or

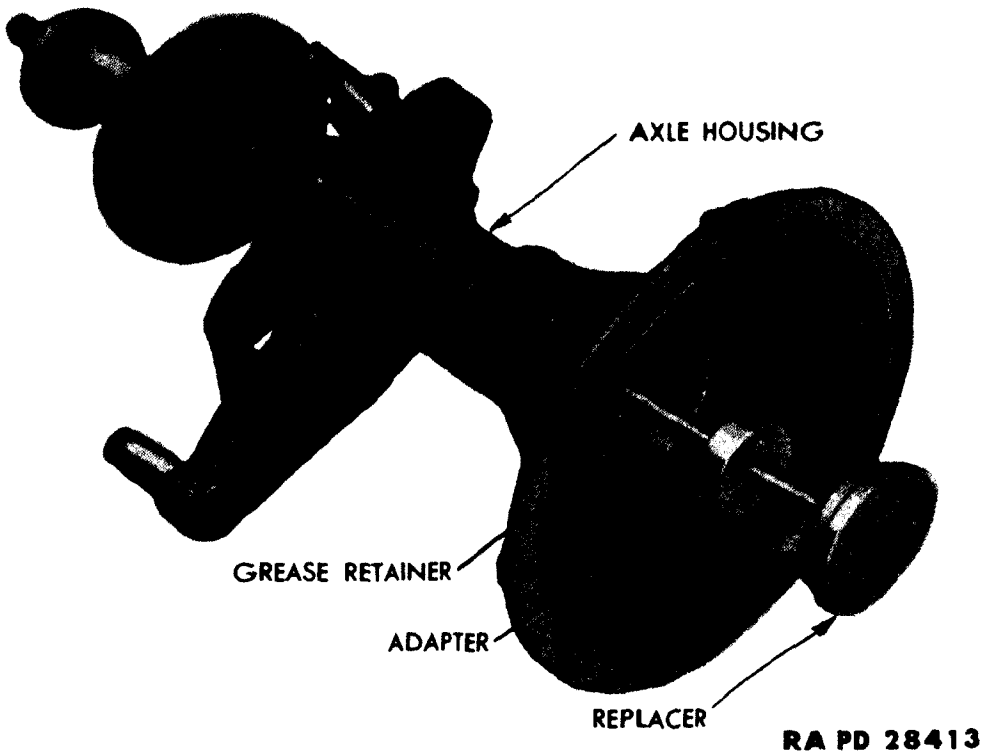


RA PD 28369

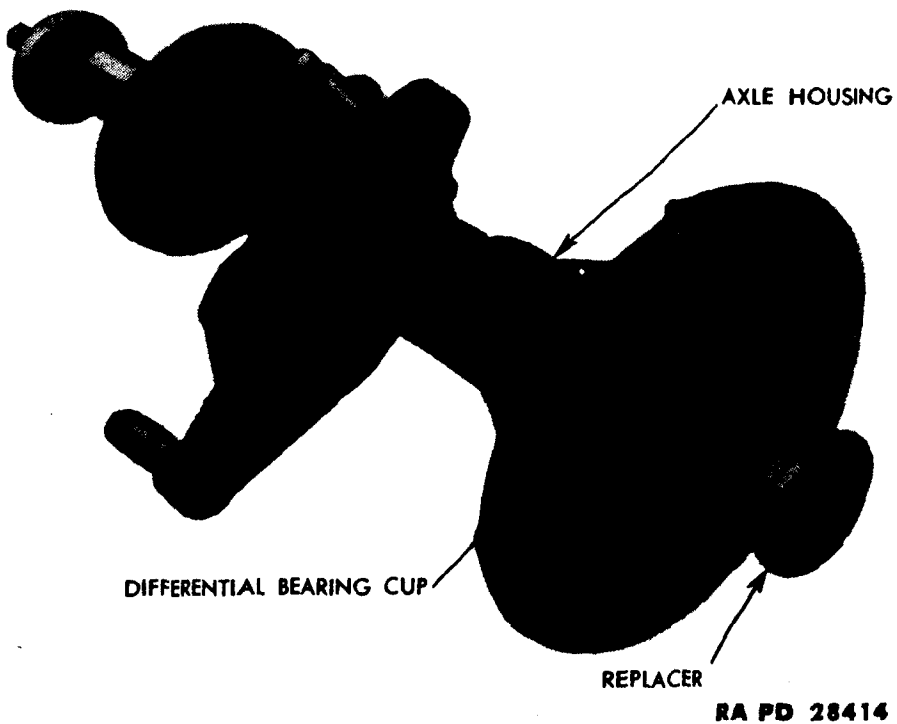
**Figure 61—Installing Hub Inner Bearing Cone on Rear of Intermediate Axle Housing with Replacer 41-R-2394-130**

cracked or bent axle housings, must be replaced. Pitted, corroded, discolored, or ridged bearing cups must be replaced. Grease seals must be replaced at every overhaul. An excessively worn thrust plate (fig. 66) (worn to thrust plate pin) must be replaced.

**ORDNANCE MAINTENANCE—POWER TRAIN, SUSPENSION, HULL,  
AND TURRET FOR ARMORED CAR M8 AND UTILITY CAR M20**



**Figure 62—Installing Grease Retainer in Axle Housing with Replacer 41-R-2390-900 and Adapter M8-116**



**Figure 63—Installing Differential Bearing Cup in Axle Housing with Replacer 41-R-2390-900 and Adapter M8-116**

## REAR AND INTERMEDIATE AXLE CLEANING, INSPECTION AND REPAIR

b. **Differential Bearing Cup Replacement.** Remove the differential bearing cup and inner grease retainer from each axle housing with a standard puller. Remove the hub inner bearing grease seal with remover (41-R-2381-350) (fig. 59). Drive the hub inner bearing grease seal on each axle housing with replacer (41-R-2394-130) and adapter (fig. 60). Drive the hub inner bearing cone on each axle housing with replacer (41-R-2394-130) (fig. 61). Install the grease retainer in each axle housing with replacer and adapter (41-R-2390-900) (fig. 62). Install the differential bearing cup in each axle housing with replacer (41-R-2390-900) (fig. 63).



RA PD 28415

**Figure 64—Worn Differential Case**

c. **Thrust Plate Replacement.** Working from the outside of the differential housing, drive the thrust plate pin out of the housing. Hold the thrust plate in position and drive a new thrust pin in the housing.

### 60. PINION GEAR SLEEVE.

a. **Inspection.** A cracked or damaged pinion gear sleeve must be replaced. Cracked, pitted, corroded, discolored, or ridged bearing cups must be replaced.



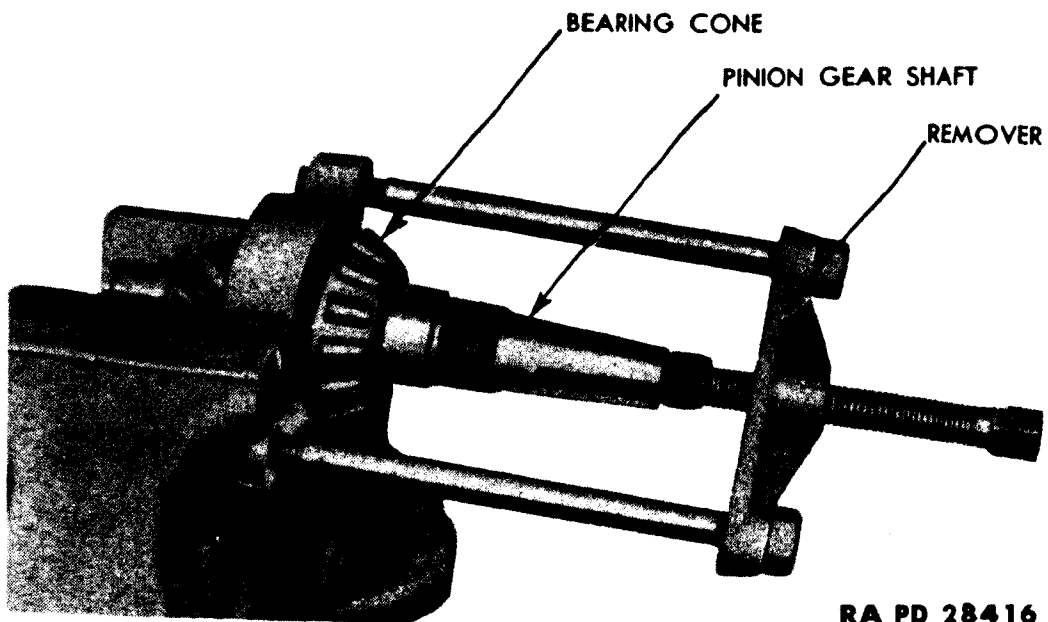
**ORDNANCE MAINTENANCE—POWER TRAIN, SUSPENSION, HULL,  
AND TURRET FOR ARMORED CAR M8 AND UTILITY CAR M20**

b. **Disassemble.** Remove each bearing cup from the pinion gear sleeve with remover (41-R-2384-41) (fig. 76).

c. **Assemble.** Press both of the bearing cups against the shoulder in the pinion gear sleeve.

**61. AXLE SHAFTS.**

a. Twisted or bent axle shafts or shafts with excessively worn or broken splines must be replaced. Axle shaft splines with small nicks will be honed and then polished with a fine stone.



**RA PD 28416**

**Figure 65—Removing Bearing Cone from Pinion Gear Shaft with Remover and Replacer 41-R-2385-135**

**62. RING GEAR AND PINION.**

a. **Inspection.** The ring gear (including differential case) and the pinion gear are furnished only in matched sets, and if either is damaged, both must be replaced. Replace ring gear if excessively worn, having broken or chipped teeth, or loose or missing differential case rivets. A differential case excessively worn by spider gear thrust washers (fig. 64) must be replaced. A pinion gear excessively worn, or with a twisted shaft, broken or chipped teeth, or damaged splines must be replaced. Pitted, corroded or discolored bearings must be replaced.

b. **Disassemble.** Pull the differential bearing cones off the differential housing with a standard bearing puller. Pull the pinion out-

**REAR AND INTERMEDIATE AXLE CLEANING, INSPECTION  
AND REPAIR**

board bearing off the pinion gear shaft with remover and replacer (41-R-2385-135) (fig. 77). Pull the bearing cone off the pinion gear shaft with remover and replacer (41-R-2385-135) (fig. 65).

c. **Assemble.** Press a bearing on each half of the differential case (fig. 68). Install the bearing cone on the pinion gear shaft (large end of the bearing toward pinion gear) with remover and replacer (41-R-2385-135) (fig. 78). Press the outboard bearing on the pinion gear shaft.

**63. SPIDER AND SPIDER GEARS.**

a. A corroded, pitted or ridged spider must be replaced. Replace the spider if it measures less than 0.8705 inch at the spider gear bearing surfaces. A spider gear measuring more than 0.8795 inch inside diameter must be replaced.

**64. AXLE SHAFT DRIVE GEARS.**

a. Replace axle shaft drive gears that have broken, chipped, or excessively worn teeth or splines. Axle shaft drive gears with more than 0.004-inch backlash when installed on the axle shafts must be replaced. Small nicks can be honed and then polished with a fine stone.

**ORDNANCE MAINTENANCE—POWER TRAIN, SUSPENSION, HULL,  
AND TURRET FOR ARMORED CAR M8 AND UTILITY CAR M20**

**CHAPTER 5**

**REAR AND INTERMEDIATE AXLES (Cont'd)**

**Section IV**

**ASSEMBLY OF REAR OR INTERMEDIATE AXLE**

	<b>Paragraph</b>
Assembly of differential.....	65
Installation of drive pinion gear in sleeve.....	66
Installation of drive pinion gear in differential housing.....	67
Installation of differential assembly.....	68
Installation of hub and brake drum assembly.....	69
Installation of hydraulic lines.....	70

**65. ASSEMBLY OF DIFFERENTIAL.**

a. Slide an axle shaft drive gear thrust washer on each axle shaft drive gear. Slide an axle shaft drive gear and thrust washer in each half of the differential case. Install the four spider gears and spider gear. (concave) thrust washers on the spider. Install the spider gear assembly between the two differential case halves, making sure the number or marking is in line on the two halves of the differential case. Install and tighten the eight differential case cap screws. Install lock wire in the eight differential case cap screws.

**66. INSTALLATION OF DRIVE PINION GEAR IN SLEEVE.**

a. Slide the drive pinion gear in the sleeve (threaded end of shaft toward flanged end of sleeve). Install the drive pinion gear adjusting nut, lock washer, and lock nut on the shaft. Tighten the adjusting nut until 12 inch-pounds preload is established. Use the tension scale (41-S-495) (fig. 67) to determine the amount of preload on the drive pinion gear shaft bearings. Hold the adjusting nut and tighten the lock nut (fig. 72) with wrenches (41-W-1470-100). Bend the tabs on the lock washers. Check the preload after tightening the lock nut. Install the outboard bearing lock ring on the pinion gear shaft.

**67. INSTALLATION OF DRIVE PINION GEAR IN DIFFERENTIAL HOUSING.**

a. Install the shim, sleeve and drive pinion assembly in the differential housing. Install the cork gasket and drive pinion cover (fig. 66)

ASSEMBLY OF REAR OR INTERMEDIATE AXLE

RA PD 28391

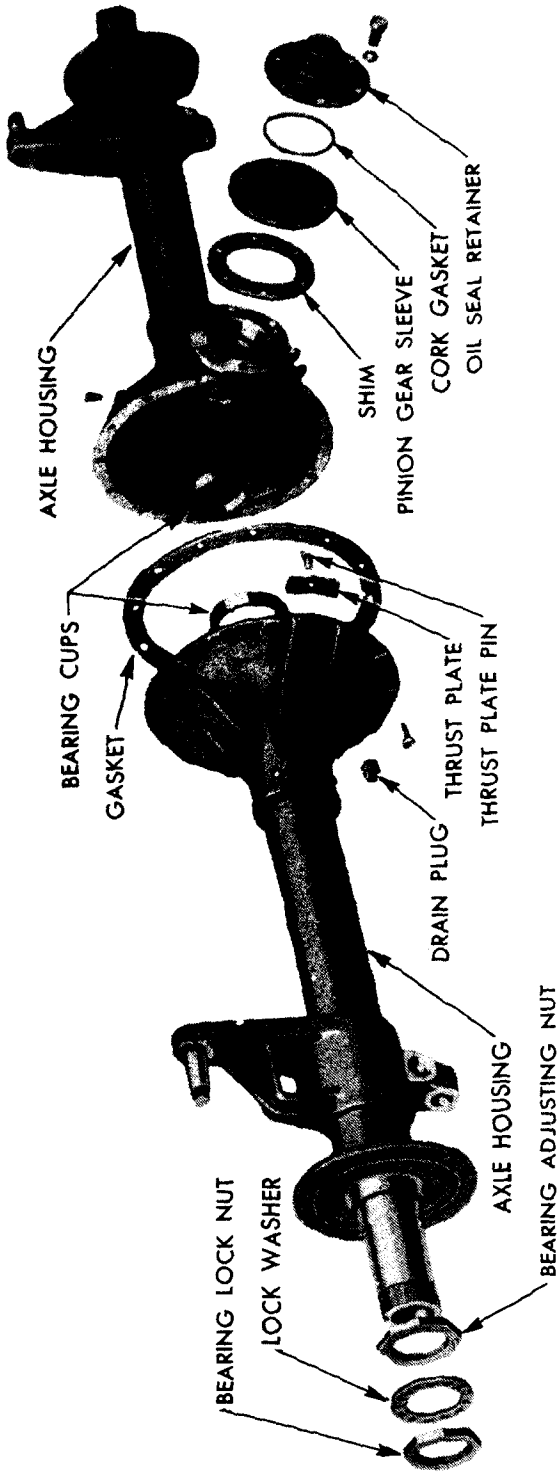


Figure 66—Rear Axle Housing, Disassembled

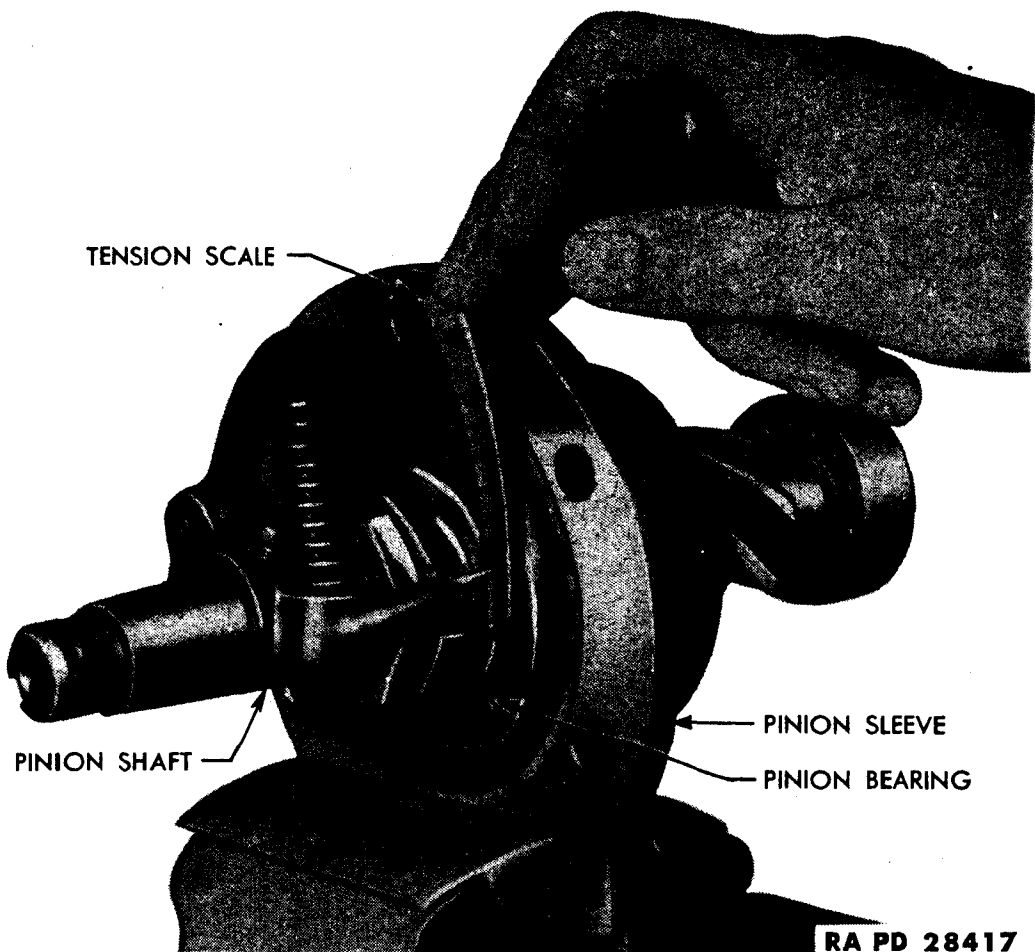
**TM 9-1743**  
**67-69**

**ORDNANCE MAINTENANCE—POWER TRAIN, SUSPENSION, HULL,  
AND TURRET FOR ARMORED CAR M8 AND UTILITY CAR M20**

on the sleeve. Install and tighten the six cap screws in the sleeve and drive pinion cover.

**68. INSTALLATION OF DIFFERENTIAL ASSEMBLY.**

a. Place the differential assembly in the drive pinion half of the axle housing. Assemble the two halves of the axle housing together with a new gasket, making sure the housings are lined up correctly by noting the position of the spring hangers. Install and tighten the 13 bolts and cap screws.

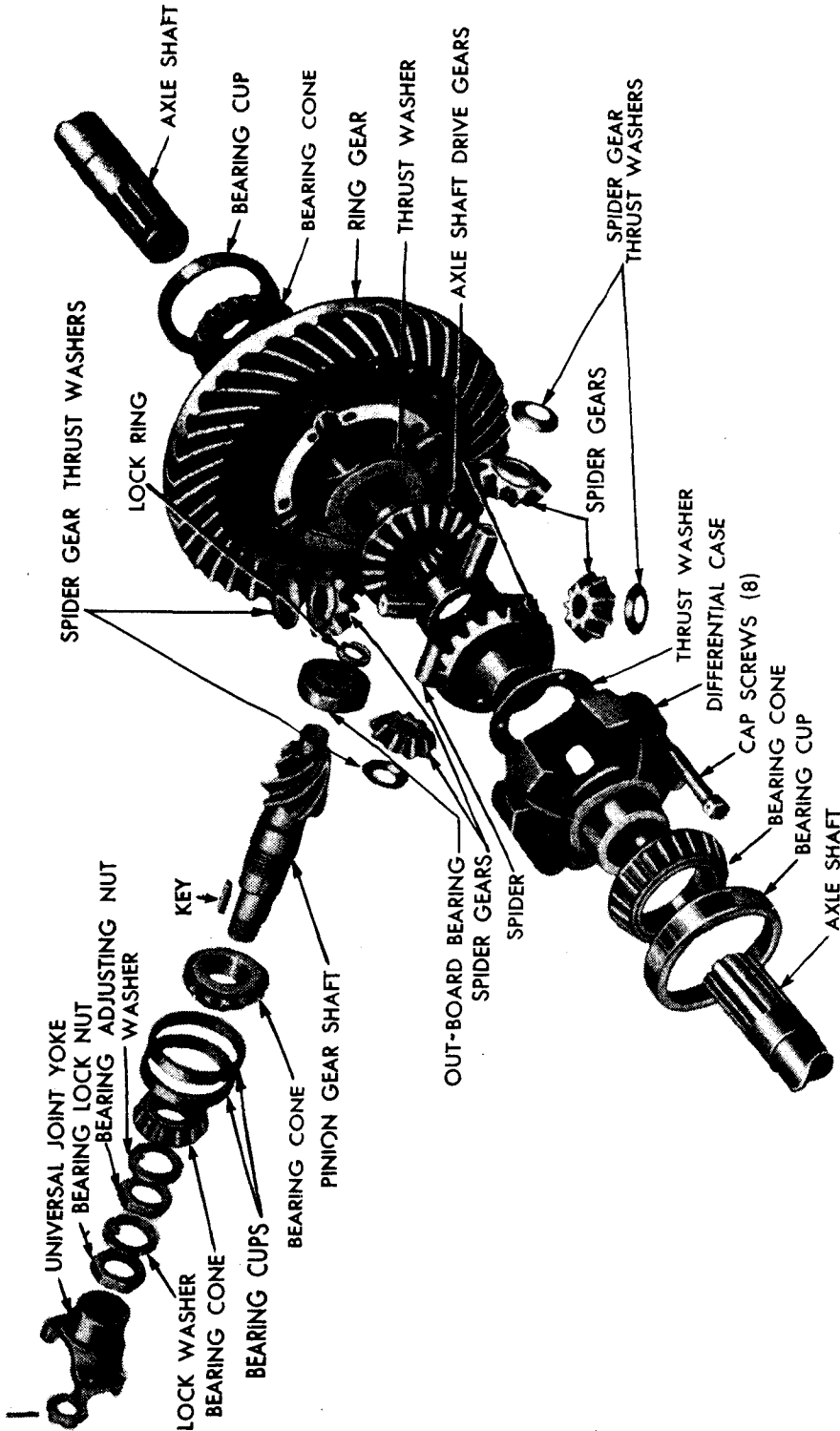


**Figure 67—Checking Preload on Pinion Gear Shaft Bearings with Tension Scale 41-S-495**

**69. INSTALLATION OF HUB AND BRAKE DRUM ASSEMBLY.**

a. Place the brake plates on the housing, making sure the slave cylinders on the brake plate are in a vertical position with the axle housing in normal position. Install the grease retainer and 12 brake

ASSEMBLY OF REAR OR INTERMEDIATE AXLE



RA PD 28392

Figure 68—Rear Axle Assembly, Gears, Shafts and Bearings, Disassembled

**TM 9-1743**  
**69-70**

**ORDNANCE MAINTENANCE—POWER TRAIN, SUSPENSION, HULL,  
AND TURRET FOR ARMORED CAR M8 AND UTILITY CAR M20**

plate bolts. Install the brake shoe retracting springs and lift the brake shoes onto the slave cylinders (fig. 57). Slide the four brake shoe hold-down bolts through the brake plate and brake shoes. Install two brake shoe hold-down cups, spring, castellated nut and cotter pin on each brake shoe hold-down bolt. Place the brake drum on the axle housing. Slide the outer wheel bearing into place in the brake drum. Install the adjusting nut and run it up tight with a wrench; then back it off (counterclockwise) 45 degrees. This establishes the correct wheel bearing adjustment. Install the lock washer, making sure the dowel on the adjustment nut is engaged with the lock washer. Install and tighten the outer bearing nut. Turn the two puller cap screws on the axle shaft counterclockwise until they are flush with the machined surface of the axle shaft. Install the gasket, axle shaft, wedges, lock washers, and nuts.

**70. INSTALLATION OF HYDRAULIC LINES.**

a. Install the hydraulic lines, guards and guard clamps on the axle housing. Connect the hydraulic line at the junction block on each brake plate. Install the brake line hold-down clamps on the axle housing.

**CHAPTER 6**  
**FRONT AXLE**

Section I

**DESCRIPTION AND DATA**

	Paragraph
Description .....	71
Data .....	72

**71. DESCRIPTION.**

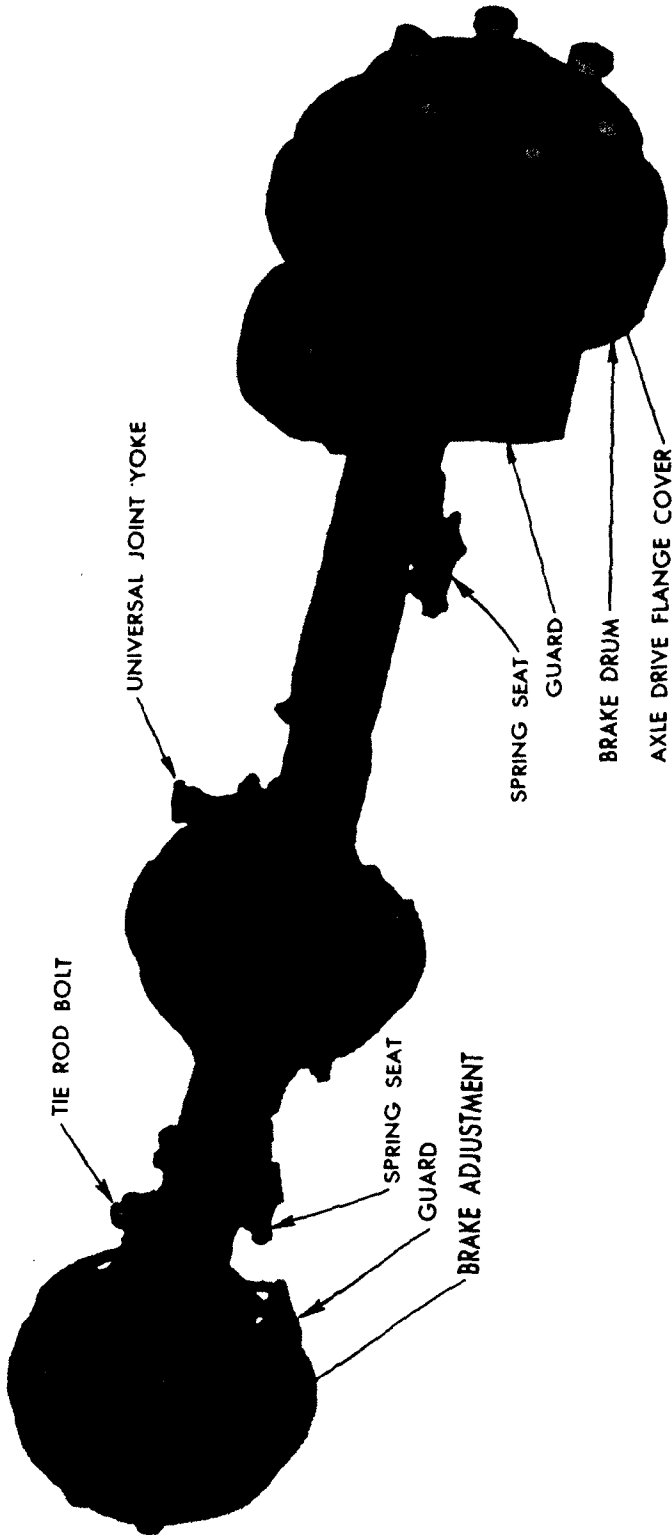
a. The front axle on the Light Armored Car M8 and Armored Utility Car M20, at the driver's option, provides a means of driving the front wheels. The axle is provided with a differential, split-type axle housings, and detachable axle housing outer ends which are used for mounting the special steering knuckle assemblies. The caster, camber, king pin inclination, and turning radius, are established in manufacture and are not adjustable. The toe-in is adjusted by regulating the length of the tie rod. Figures 69 and 70 show the front and rear views of the front axle ready to be installed in the vehicle.

**72. DATA.**

Ratio .....	6.66 to 1.0
Type axle .....	Full floating
Made by .....	Timken Detroit Axle Co.
Caster .....	2 deg
Camber .....	$\frac{3}{4}$ deg
Toe-in .....	$\frac{3}{16}$ in.
Side inclination of spindle pin .....	8 deg
Wheelbase:	
Front to intermediate .....	80 in.
Front to rear axle .....	128 in.
Tread:	
Front .....	76 in.
Rear .....	76 in.
Turning radius .....	27.5 ft



ORDNANCE MAINTENANCE—POWER TRAIN, SUSPENSION, HULL,  
AND TURRET FOR ARMORED CAR M8 AND UTILITY CAR M20



RA PD 28418

Figure 69—Front View of Front Axle

DESCRIPTION AND DATA

RA PD 28419

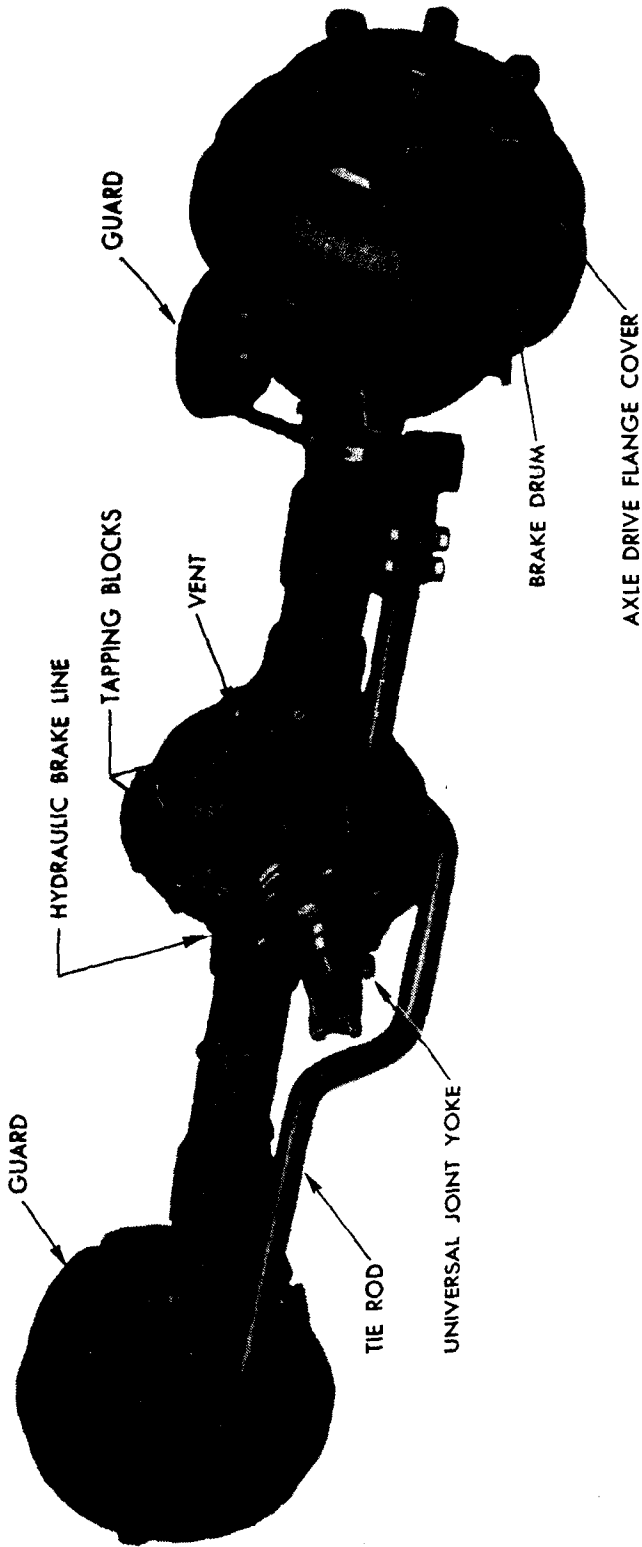


Figure 70—Rear View of Front Axle

**ORDNANCE MAINTENANCE—POWER TRAIN, SUSPENSION, HULL,  
AND TURRET FOR ARMORED CAR M8 AND UTILITY CAR M20**

**CHAPTER 6**

**FRONT AXLE (Cont'd)**

**Section II**

**DISASSEMBLY OF FRONT AXLE**

	<b>Paragraph</b>
Preliminary work .....	73
Removal of axle shaft .....	74
Removal of steering knuckles .....	75
Removal of differential .....	76
Removal of drive pinion gear shaft from sleeve .....	77
Disassembly of differential .....	78

**73. PRELIMINARY WORK.**

a. Remove the brake hydraulic line guard clamps and guards. Disconnect the brake line at the junction block on each brake plate. Remove the brake line hold-down clamps and the junction block on the axle housing. Lift the brake line from the housing.

**74. REMOVAL OF AXLE SHAFT.**

a. **Remove Brake Drums** (fig. 69). Remove the eight nuts and lock washers that hold the drive flange cover to the hub and lift off the cover. Remove the cotter pin and castellated nut from the axle shaft. Install and tighten two  $\frac{3}{8}$ -inch standard thread cap screws in the drive flange to force it part way off the axle shaft. Pry the drive flange the rest of the way off the axle shaft. Remove the lock nut, lock washer, and adjusting nut. Pull the hub and drum off the spindle.

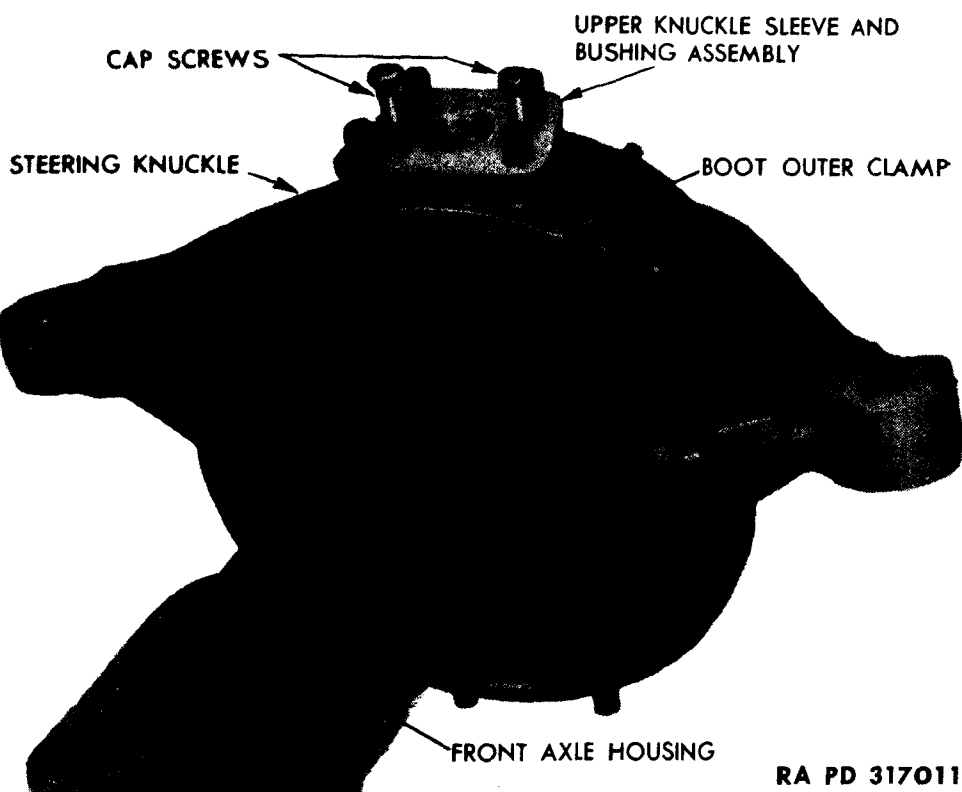
b. **Remove Brake Plates and Spindles** (fig. 101). Remove the two hold-down bolts from each brake shoe and lift off the shoes (fig. 57). Remove the 12 bolts that hold the brake plate and spindle to the steering knuckle. Tap the brake plate assembly and spindle off the steering knuckle with a brass hammer. Pull the axle shafts out of the axle housings.

**75. REMOVAL OF STEERING KNUCKLES.**

a. **Remove Tie Rod.** Remove the cotter pin and castellated nut from each end of the tie rod. Drive each tie rod ball joint out of the spindle arms.

### DISASSEMBLY OF FRONT AXLE

b. **Remove Steering Knuckles.** Remove four cap screws from both the upper and lower knuckle sleeve and bushing plate. Remove plates. Install two  $\frac{3}{8}$ -inch S.A.E. thread cap screws  $1\frac{1}{2}$  inches long in each knuckle sleeve and bushing. Tighten the cap screws to force the knuckle sleeve and bushing off the trunnion (fig. 71). Remove the outer rubber boot clamps and slip the boots off the steering knuckle. Lift the steering knuckle off the axle housings.



**Figure 71—Removing Knuckle Sleeve and Bushing from Trunnion**

### 76. REMOVAL OF DIFFERENTIAL.

a. **Disassemble Axle Housing.** Remove the drain plug and drain the axle. Remove the 13 bolts and cap screws that hold the axle housings together. Lift the differential from the housings.

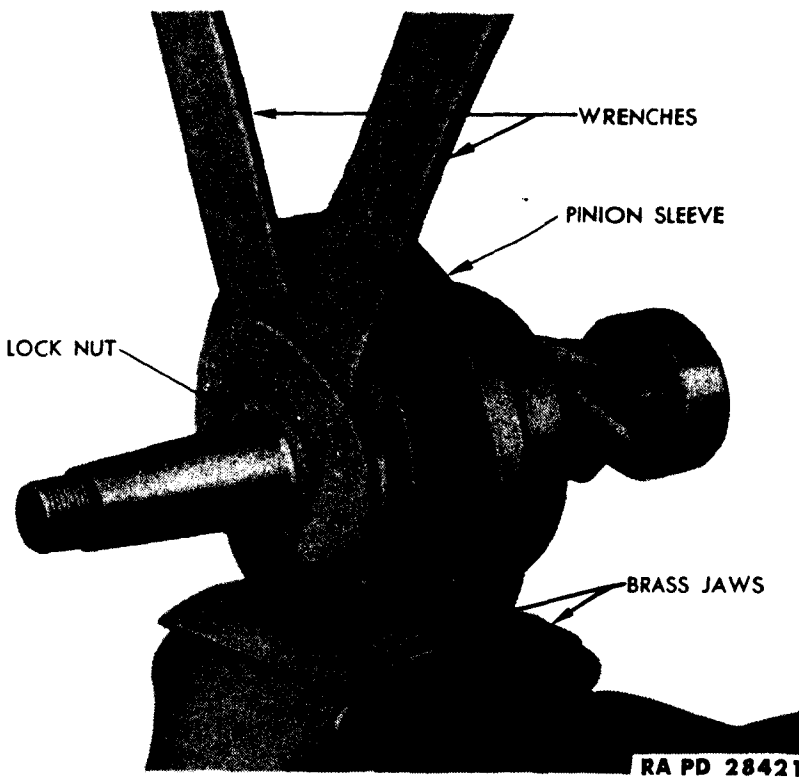
b. **Remove Universal Joint Yoke.** Remove the cotter pin and castellated nut that hold the universal joint yoke to the pinion gear shaft. Pull the universal joint yoke off the shaft with puller (41-R-2384-82) (fig. 58).

c. **Remove Pinion Gear and Shaft Assembly.** Remove the six cap screws that hold the pinion gear and shaft assembly in the differential housing. Tap on the end of the pinion gear shaft from inside the housing with a brass hammer and drive the assembly from the housing.

**ORDNANCE MAINTENANCE—POWER TRAIN, SUSPENSION, HULL,  
AND TURRET FOR ARMORED CAR M8 AND UTILITY CAR M20**

**77. REMOVAL OF DRIVE PINION GEAR SHAFT FROM  
SLEEVE.**

a. Straighten the tab on the lock washer. Remove the lock nut, lock washer, and adjustment nut with the two pinion lock nut adjusting wrenches (41-W-1470-100) (fig. 72) and slide the drive pinion from the sleeve. Lift the front bearing cone and sleeve off the pinion gear shaft.



RA PD 28421

**Figure 72—Removing Pinion Shaft Adjusting Nut and Lock Nuts with Wrench 41-W-1470-100**

**78. DISASSEMBLY OF DIFFERENTIAL.**

a. Remove the lock wire and eight differential cap screws from the differential housing (fig. 68). Tap the left-hand differential case off the ring gear case with a brass hammer. Lift out the spider, spider gears, and spider gear thrust washers. Slide the axle shaft gear and thrust washer from the (right- and left-hand) differential case.

**CHAPTER 6**  
**FRONT AXLE (Cont'd)**

**Section III**

**FRONT AXLE CLEANING, INSPECTION, AND REPAIR**

	<b>Paragraph</b>
Cleaning .....	79
Axle housing .....	80
Pinion gear sleeve .....	81
Axle shafts .....	82
Ring gear and pinion .....	83
Spider and spider gears .....	84
Axle shaft drive gears .....	85
Spindles .....	86
Steering knuckles .....	87

**79. CLEANING.**

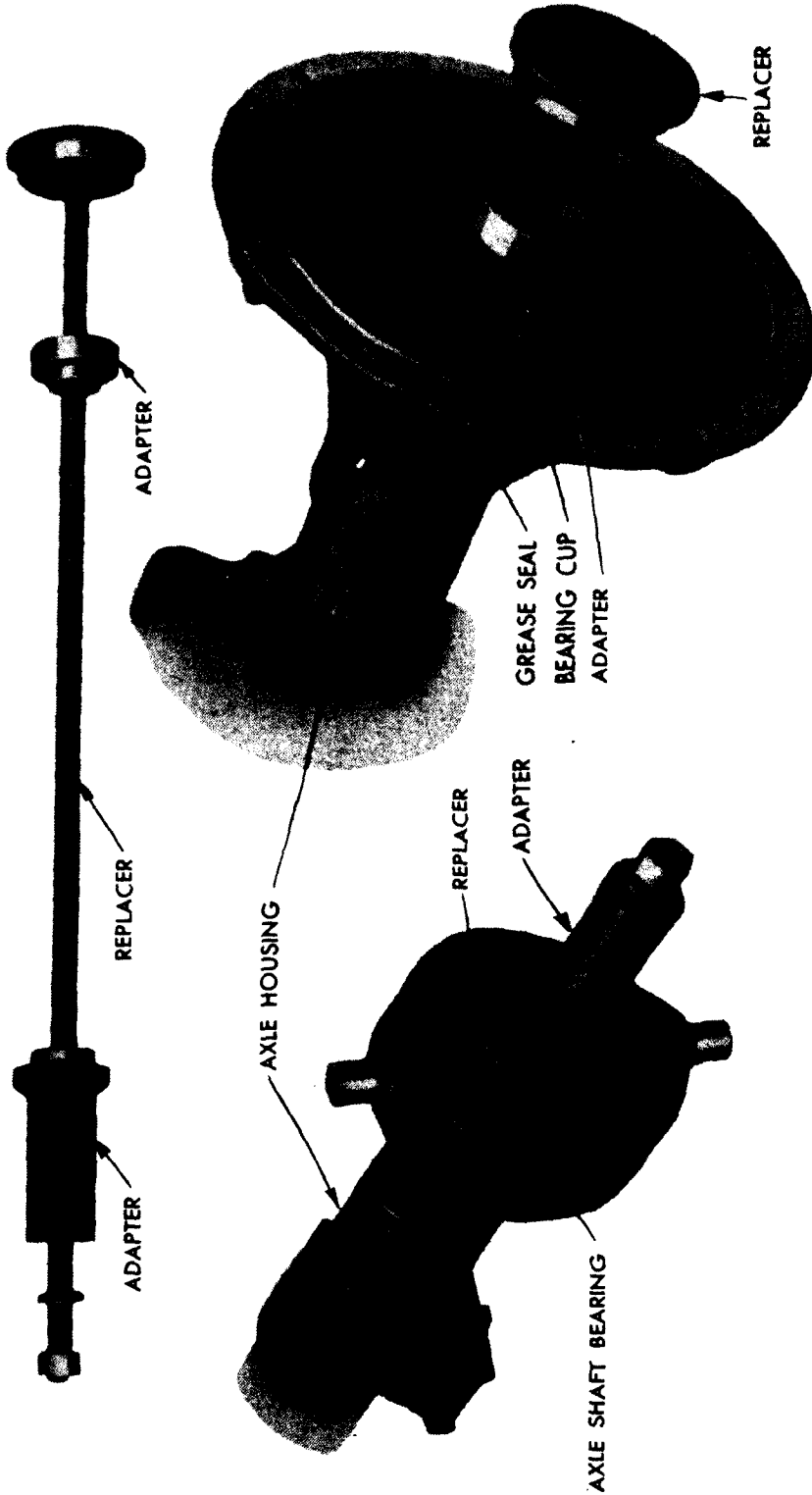
a. Wash all parts thoroughly in dry-cleaning solvent. Rotate the bearings while immersed in clean dry-cleaning solvent until all trace of old lubricant has been removed. Oil the bearings immediately after cleaning to prevent corrosion of highly polished surfaces.

**80. AXLE HOUSING.**

a. **Inspection.** Replace axle housings with broken welds, missing tapping blocks, broken, missing, or loose rivets or damaged threads, and cracked or bent axle housings. Pitted, corroded, discolored, or ridged bearing cups must be replaced. Grease seals must be replaced at every overhaul. Axle housings with ridged trunnions or with trunnions worn to less than a 1.1205-inch diameter must be replaced. Axle shaft bushings measuring over 1.882 inch must be replaced. Knuckle sleeves and bushings measuring over 1.245 inch must be replaced (par. 80 d). Swelled, torn, or distorted boots must be discarded. An excessively worn thrust plate (worn down to the pin) must be replaced.

b. **Differential Bearing Cup and Axle Shaft Bushing Replacement.** Remove the differential bearing cup and inner grease retainer from each axle housing with a standard puller. Remove the inner boot clamp and slip the boot off the housing. Pull the outer axle shaft bushing assembly from the axle housing with a standard bearing

ORDNANCE MAINTENANCE—POWER TRAIN, SUSPENSION, HULL,  
AND TURRET FOR ARMORED CAR M8 AND UTILITY CAR M20



RA PD 28422

Figure 73—Installing Grease Seal, Differential Bearing Cup and Axle Shaft Outer Bearing in Axle Housing with Replacer 41-R-2390-900 and Adapters M8-116-A, B and C

FRONT AXLE CLEANING, INSPECTION, AND REPAIR

RA PD 317010

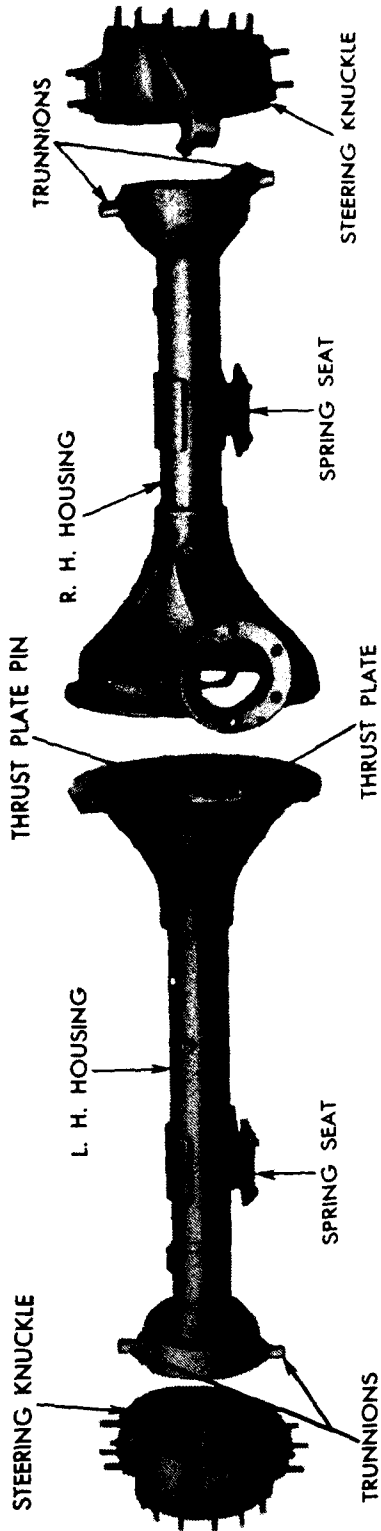


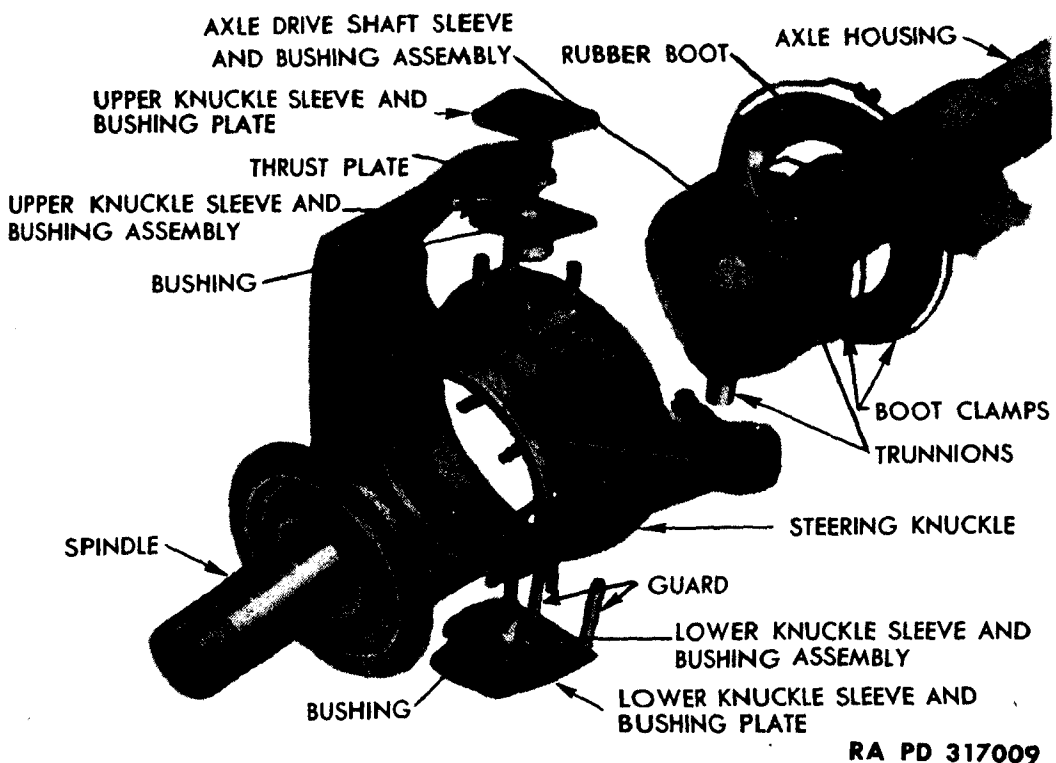
Figure 74—Front Axle and Steering Knuckles



**ORDNANCE MAINTENANCE—POWER TRAIN, SUSPENSION, HULL,  
AND TURRET FOR ARMORED CAR M8 AND UTILITY CAR M20**

puller. Slide the differential bearing cup on replacer (41-R-2390-900) and adapter M8-116A. Slide adapter M8-116B on the replacer. Install the inner grease seal onto adapter M8-116B. Slide the replacer assembly through the axle housing. Install the axle shaft outer bushing adapter M8-116C and nut on the replacer shaft. Tighten the nut to draw the assemblies in place (fig. 73). Install the boot and inner clamp on the axle housing and tighten the clamp.

c. **Thrust Plate Replacement** (fig. 74). Working from the outside of the differential housing, drive the thrust plate pin out of the housing. Hold the thrust plate in position, and drive a new thrust plate pin in the housing.



**Figure 75—Steering Knuckle Disassembled**

d. **Knuckle Sleeve and Bushing Replacement.** Drive bushing from the sleeve. Press the new bushing into sleeve and ream bushing to size.

**81. PINION GEAR SLEEVE.**

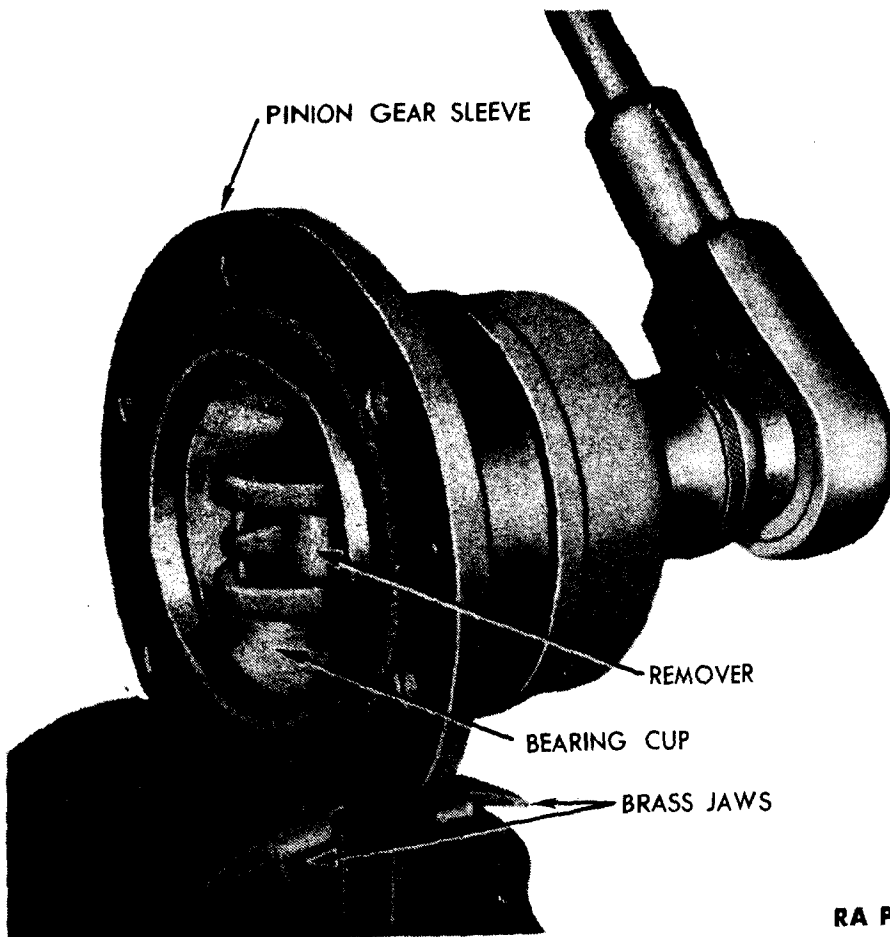
a. **Inspection.** A cracked or damaged pinion gear sleeve must be replaced. Cracked, pitted, corroded, discolored, or ridged bearing cups must be replaced.

## FRONT AXLE CLEANING, INSPECTION, AND REPAIR

b. **Pinion Bearing Cup Replacement.** Remove each bearing cup from the pinion gear sleeve with remover (41-R-2384-41) (fig. 76). Install new bearing cups, pressing both bearing cups against the shoulder in the pinion gear sleeve.

### 82. AXLE SHAFTS.

a. **Inspection.** Replace any parts that are bent, twisted, broken, or excessively worn. Replace the outer axle shaft if the bearing surface is worn to less than a 1.870-inch diameter. Replace the inner axle shaft if the bearing surface is worn to less than a 1.872-inch diameter. Axle shaft splines with small nicks will be honed and polished with a fine stone.



RA PD 28370

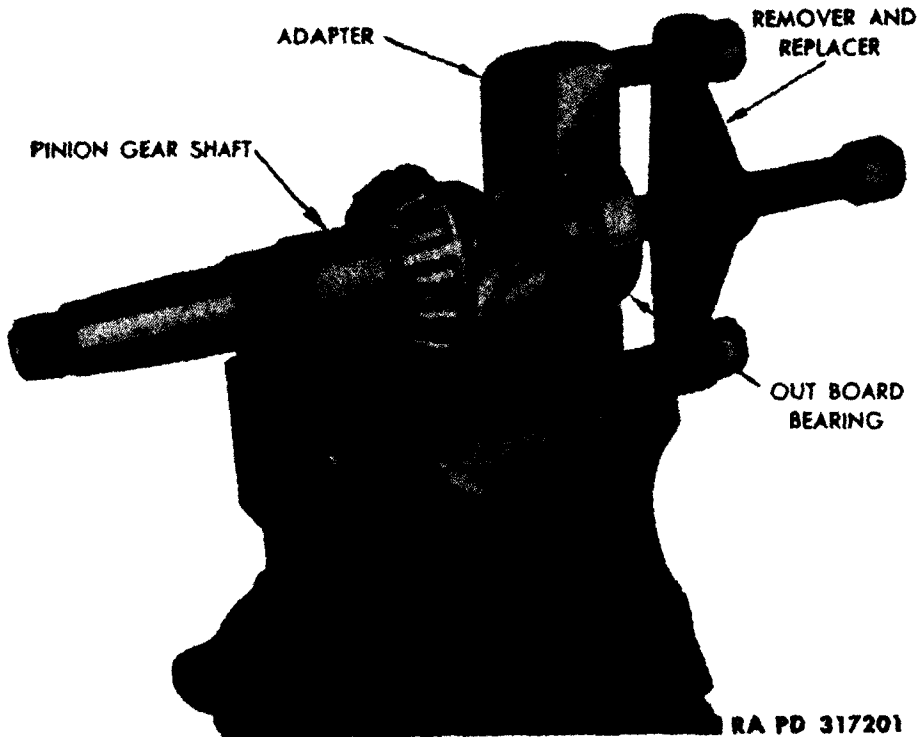
**Figure 76—Removing Bearing Cups from Pinion Gear Sleeve with Remover 41-R-2384-41**

### 83. RING GEAR AND PINION.

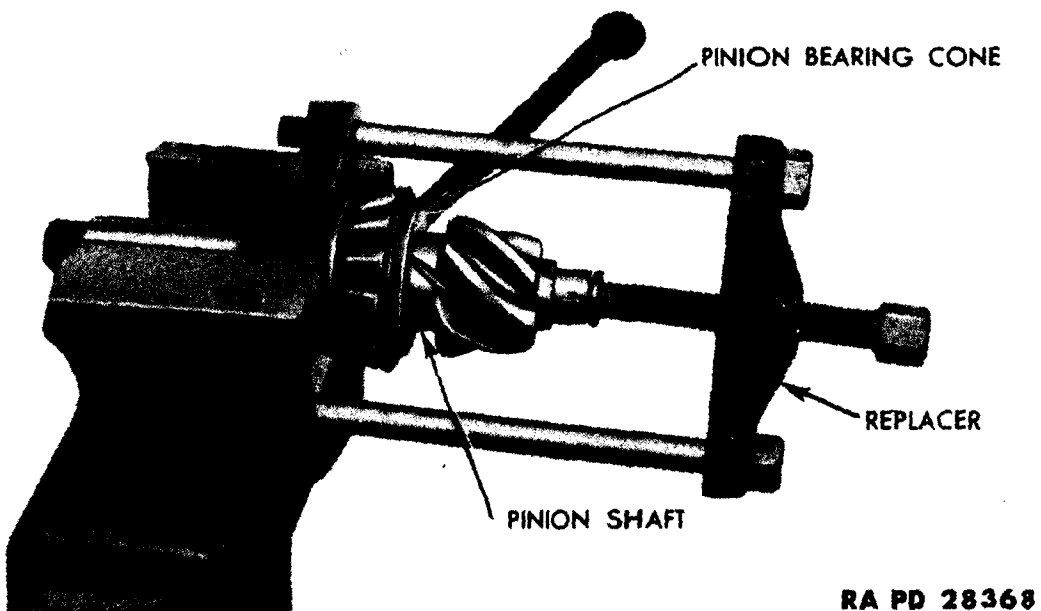
a. **Inspection.** The ring gear (including the differential case) and the pinion gear are furnished only in matched sets, and if either is

TM 9-1743  
83

**ORDNANCE MAINTENANCE—POWER TRAIN, SUSPENSION, HULL,  
AND TURRET FOR ARMORED CAR M8 AND UTILITY CAR M20**



**Figure 77—Removing Outboard Bearing from Pinion Gear Shaft with Remover and Replacer 41-R-2385-135 and Adapters M8-122A**



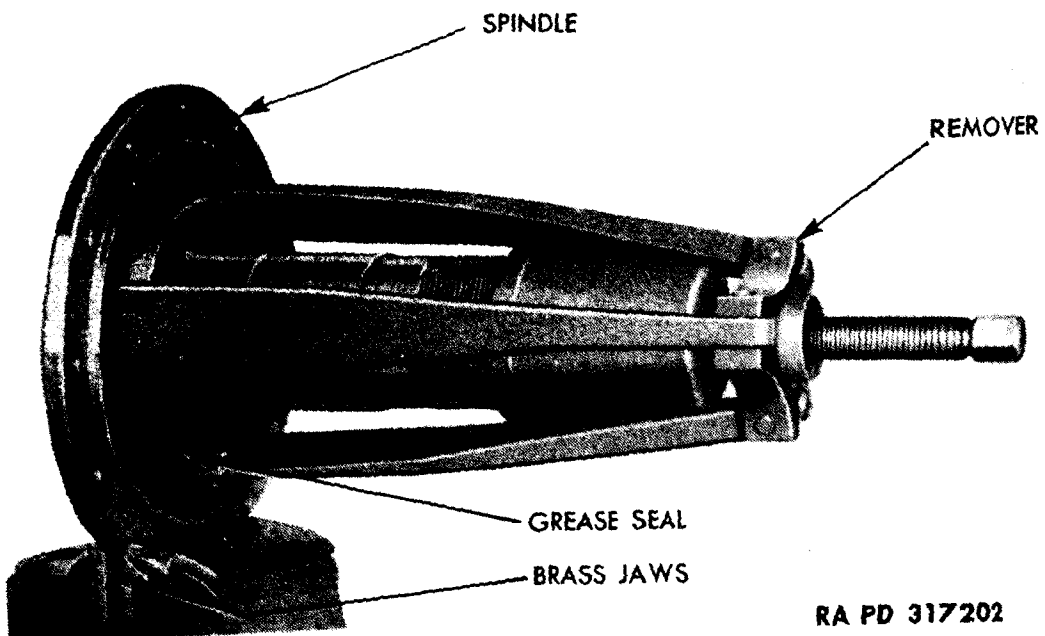
**Figure 78—Installing Bearing Cone on Pinion Gear Shaft with Remover and Replacer 41-R-2385-135 and Adapter M8-122B**

### FRONT AXLE CLEANING, INSPECTION, AND REPAIR

damaged, both must be replaced. Replace ring gear if excessively worn or if it has broken or chipped teeth, or loose or missing differential case rivets. A differential case, excessively worn by spider gear thrust washers (fig. 64), must be replaced. Replace pinion gear if excessively worn or if it has a twisted shaft, broken or chipped teeth, or damaged splines. Pitted, corroded, or discolored bearings must be replaced.

**b. Disassemble.** Pull the differential bearing cones off the differential case with a standard bearing puller. Pull the pinion outboard bearing off the pinion gear shaft with puller and adapter (41-R-2385-135) (fig. 77). Pull the bearing cone off the pinion gear shaft with remover (41-R-2385-135) (fig. 65).

**c. Assemble.** Press a bearing on each half of the differential case. Install the bearing on the pinion gear shaft (large end of bearing toward pinion gear) with replacer and adapter (41-R-2385-135) (fig. 78). Press the outboard bearing on the pinion gear shaft.



RA PD 317202

**Figure 79—Removing Hub Inner Grease Seal from Axle Spindle with Puller 41-R-2381-350**

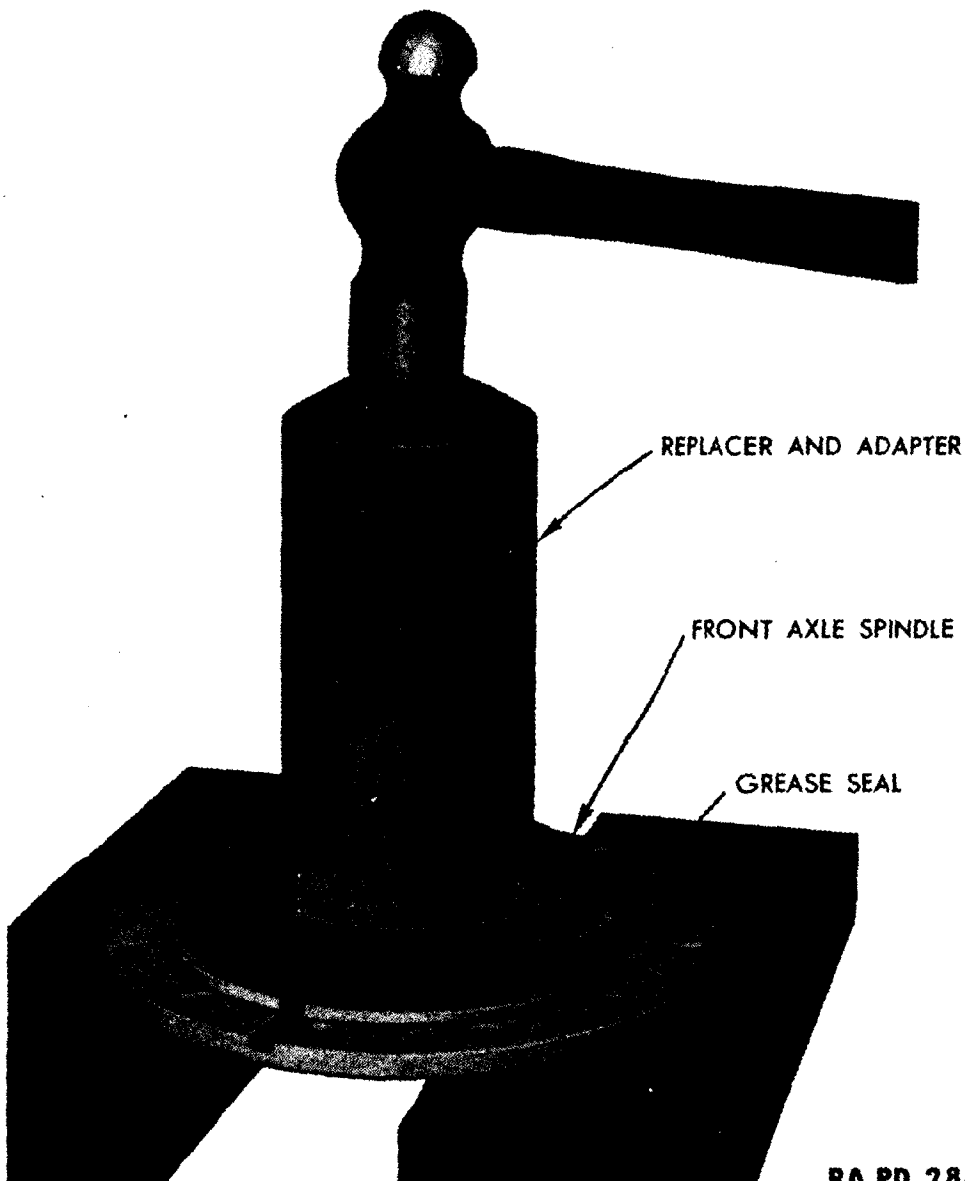
#### 84. SPIDER AND SPIDER GEARS.

**a.** A corroded, pitted, or ridged spider must be replaced. Replace the spider if it measures less than 0.8705 inch at the spider gear bearing surfaces. A spider gear measuring more than 0.8795-inch inside diameter must be replaced.

**ORDNANCE MAINTENANCE—POWER TRAIN, SUSPENSION, HULL,  
AND TURRET FOR ARMORED CAR M8 AND UTILITY CAR M20**

**85. AXLE SHAFT DRIVE GEARS.**

a. Axle shaft drive gears that have broken or chipped teeth, excessively worn teeth, or splines must be replaced. Axle shaft drive gears with more than 0.004-inch backlash, when installed on axle shaft, must be replaced. Small nicks will be honed and polished with a fine stone.



RA PD 28371

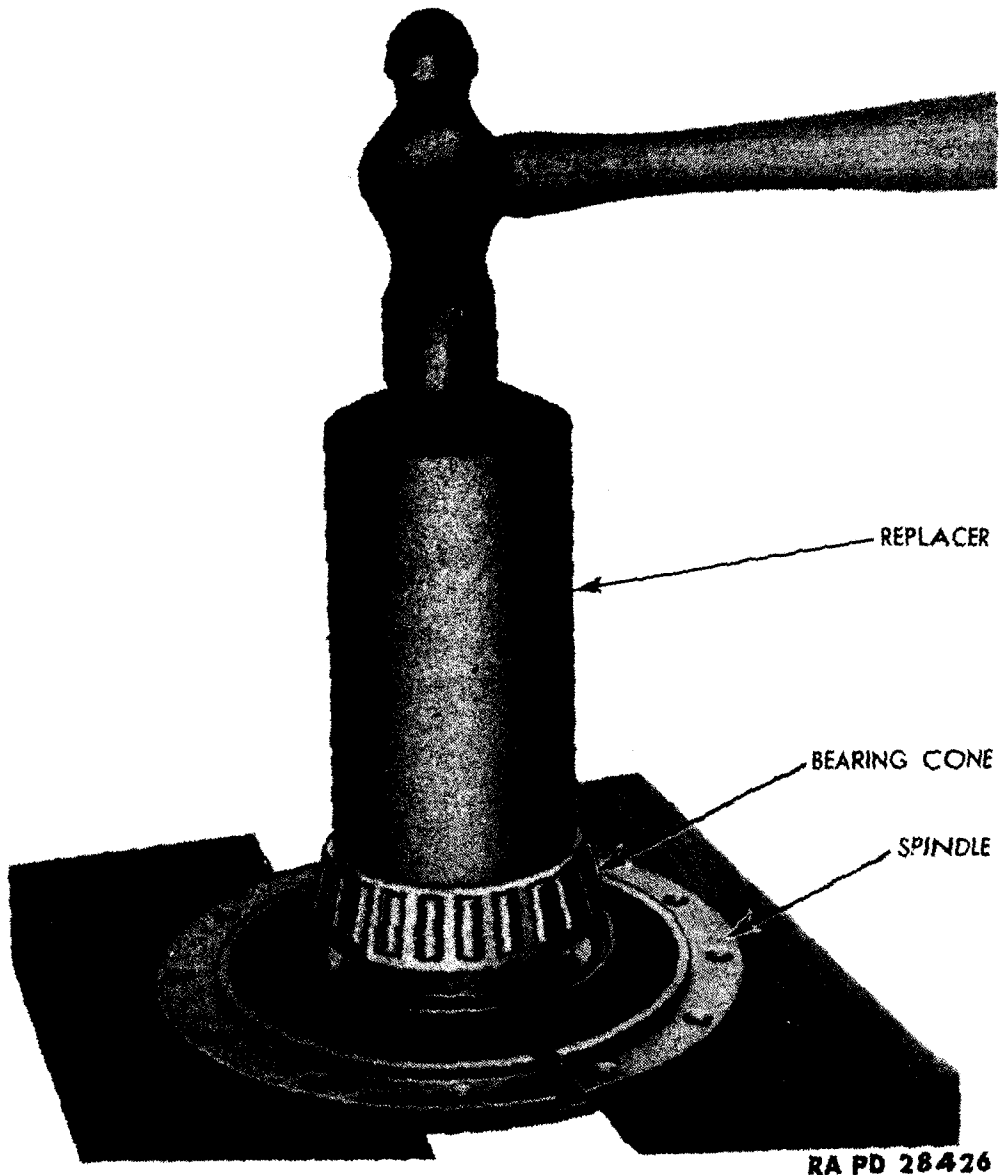
**Figure 80—Installing Hub Inner Grease Seal on Spindle with Replacer 41-R-2394-130 and Adapter M8-121**

**86. SPINDLES.**

a. **Inspection.** Bent or damaged steering knuckles must be replaced. Axle shaft bearings, in spindles measuring larger than 1.912

**FRONT AXLE CLEANING, INSPECTION, AND REPAIR**

inches, must be replaced. Pitted, corroded, or discolored bearing cones must be replaced. Grease seals must be replaced at every overhaul.



**Figure 81—Installing Bearing Cone on Spindle with Replacer 41-R-2394-130**

b. **Disassemble.** Remove the axle shaft bushing from the spindle with a small chisel. Pull the bearing cone off the spindle. Remove the hub inner grease seal with remover (41-R-2381-350) (fig. 79).

c. **Assemble.** Press the axle shaft bushing in the spindle with a bushing replacer. Install the hub inner grease seal on the spindle with replacer (41-R-2394-130) and adapter (M8-121) (fig. 80). Install

**TM 9-1743**

**86-87**

**ORDNANCE MAINTENANCE—POWER TRAIN, SUSPENSION, HULL,  
AND TURRET FOR ARMORED CAR M8 AND UTILITY CAR M20**

the bearing cone on the spindle with replacer (41-R-2394-130) (fig. 81).

**87. STEERING KNUCKLE.**

a. Cracked steering knuckles must be replaced. All damaged studs must be replaced. Steering knuckles with loose stop bolts must be replaced.

## CHAPTER 6

### FRONT AXLE (Cont'd)

#### Section IV

### ASSEMBLY OF FRONT AXLE

	Paragraph
Assembly of differential .....	88
Installation of drive pinion gear in sleeve .....	89
Installation of drive pinion gear in differential housing .....	90
Installation of differential assembly .....	91
Installation of steering knuckle .....	92
Installation of hub and brake drum .....	93
Installation of hydraulic lines .....	94

#### 88. ASSEMBLY OF DIFFERENTIAL.

a. Slide an axle shaft drive gear thrust washer on each axle shaft drive gear. Slide an axle shaft drive gear and thrust washer in each half of the differential case. Install the four spider gears and spider gear (concave) thrust washers on the spider. Install the spider gear assembly between the two differential case halves, making sure the number or marking is in line on the two halves of the differential case. Install and tighten the eight differential case cap screws. Fasten the eight cap screws together with locking wire.

#### 89. INSTALLATION OF DRIVE PINION GEAR IN SLEEVE.

a. Slide the drive pinion gear in the sleeve (threaded end of shaft toward flanged end of sleeve). Install the drive pinion gear adjusting nut, lock washer, and lock nut on the shaft. Tighten the adjusting nut until a 12 inch-pound preload is established. Use the tension scale (41-S-495) (fig. 67) to determine the amount of preload on the drive pinion gear. Hold the adjusting nut, and tighten the lock nut with wrenches (41-W-1470-100) (fig. 72). Bend the tabs on the lock washers. Check the preload after tightening the lock nut. Install the outboard bearing lock ring on the pinion gear shaft.

#### 90. INSTALLATION OF DRIVE PINION GEAR IN DIFFERENTIAL HOUSING.

a. Install the shim, sleeve, and drive pinion assembly in the differential housing. Install the cork gasket and the drive pinion cover on the sleeve. Install and tighten the six cap screws in the sleeve, and drive pinion cover.



**ORDNANCE MAINTENANCE—POWER TRAIN, SUSPENSION, HULL,  
AND TURRET FOR ARMORED CAR M8 AND UTILITY CAR M20**

**91. INSTALLATION OF DIFFERENTIAL ASSEMBLY.**

a. Place the differential assembly in the drive pinion half of the axle housing. Assemble the two halves of the axle housing together with a new gasket, making sure the housings are lined up correctly by noting the position of the spring hangers. Install and tighten the 13 bolts and cap screws.

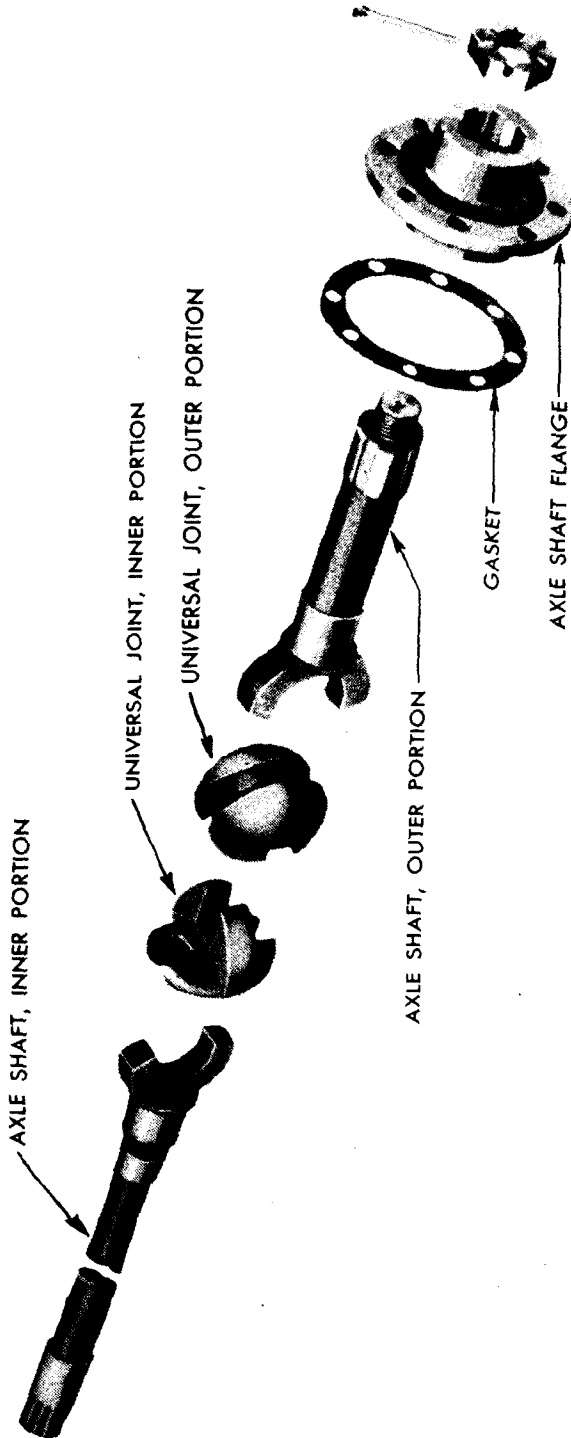
**92. INSTALLATION OF STEERING KNUCKLE (fig. 75).**

a. Place the steering knuckle boot on the axle. Place the steering knuckle on the axle housing with the spindle arms toward the rear of the axle. Tap the lower (long), knuckle sleeve and bushing lightly into the steering knuckle and onto the trunnion. Install the lower knuckle sleeve and bushing plate, guard, four nuts and lock washers. Lift up on the steering knuckle, tap the upper (short) knuckle sleeve and bushing lightly into the housing and onto the trunnion. Several different thicknesses of knuckle sleeve and bushing plates are provided to control the vertical movement of the steering knuckle. Select a plate that is just flush with the top of the knuckle sleeve when the steering knuckle is pushed upward and place it on the upper knuckle sleeve and bushing. Install the guard, four lock washers, and nuts. If vertical end play exists, a thicker plate must be used. If the steering knuckle binds on the trunnions, a thinner plate must be used. Vertical end play up to 0.003 inch is permissible. Secure axle housing boot to axle and steering knuckle with clamps (fig. 75).

**93. INSTALLATION OF HUB AND BRAKE DRUM.**

a. Slide the inner portion of the axle shaft and the inner portion of the universal joint into the axle housing (fig. 82). Place the outer portion of the axle shaft and the outer portion of the universal joint into the spindle (fig. 82). Place the spindle on the studs of the steering knuckle with the key slot facing toward the top of the axle, making sure the inner and outer portion of the universal joint is engaged. Place the spindle and brake plate on the steering knuckle studs, making sure that the slave cylinders on the brake plate are in a vertical position, with the axle housing in normal position. Install the nuts and the lock washers. Install the brake shoe retracting springs and lift the shoes onto the slave cylinders (fig. 57). Slide the four brake shoe hold-down bolts through the brake plate and brake shoes. Install the two brake shoe hold-down cups, spring, castellated nut, and cotter pin on each brake shoe hold-down bolt (fig. 101). Place the hub and brake drum on the spindle. Slide the outer wheel bearing into place in

ASSEMBLY OF FRONT AXLE



RA PD 28451

Figure 82—Front Axle Drive Shaft and Universal Joint, Disassembled

## **TM 9-1743**

**93-94**

### **ORDNANCE MAINTENANCE—POWER TRAIN, SUSPENSION, HULL, AND TURRET FOR ARMORED CAR M8 AND UTILITY CAR M20**

the hub. *NOTE: Lubricate bearing before installing in hub.* Install the adjusting nut and run it up tight with a wrench; then back it off (counterclockwise) 45 degrees ( $\frac{1}{8}$  turn). This establishes the correct wheel bearing adjustment. Install the lock washer, making sure the dowel on the adjustment nut is engaged with the lock washer. Install and tighten the outer bearing nut. Hold the tie rod in place in the spindle arms and install the castellated nuts and cotter pins. Place a new gasket on the hub. Install the drive flange and secure to the axle shaft with the castellated nut and cotter pin. Install the drive flange cover, lock washers, and nuts.

#### **94. INSTALLATION OF HYDRAULIC LINES.**

a. Install the hydraulic lines, guards, guard clamps, and junction block on the axle housing. Connect the hydraulic line at the junction block on each brake plate and on the axle housing junction block. Install the brake line hold-down clamps on the axle housing.

## CHAPTER 7

**BOGIE, SPRINGS, SHACKLES, AND SHOCK ABSORBERS**

	Paragraph
Bogie .....	95
Springs .....	96
Shackles .....	97
Shock absorbers .....	98

**95. BOGIE.**

a. **Description.** The bogie (fig. 83), which is the rear supporting unit of the vehicle, allows the rear wheels to rise or lower independently of each other as they pass over irregularities in the ground surface.

b. **Disassemble** (fig. 84). Remove the four cap screws from the bogie bearing cover and remove the cover. Bend the lock washer lugs back from the lock nut. Remove the lock nut and lock washer. Remove the bogie bearing adjusting nut. Remove the flat washer and outer bearing from the bogie shaft. Slide the spring seat bracket off the bogie shaft.

c. **Clean** (fig. 84). Wash the bogie spring seat bracket and all other parts with dry-cleaning solvent.

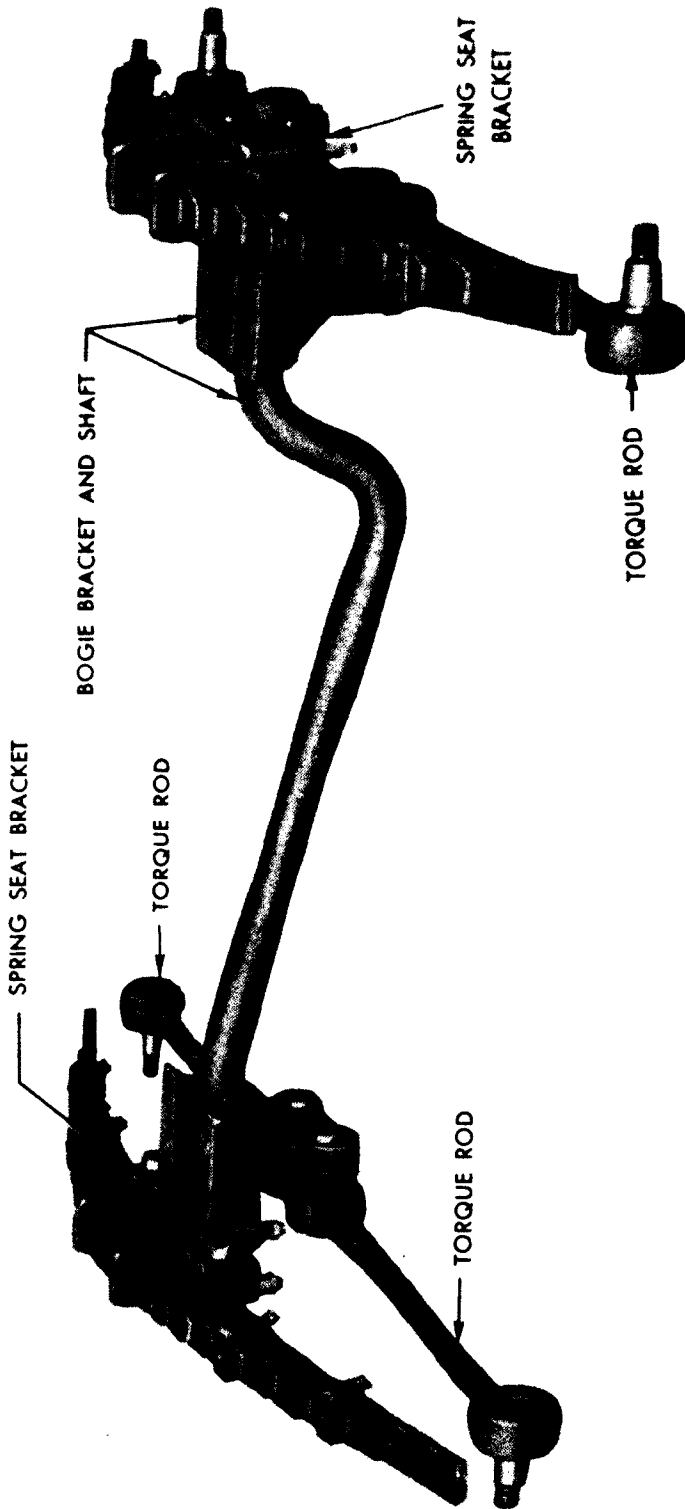
**d. Inspect and Repair.**

(1) **BOGIE BRACKET AND SHAFT.** Replace the bogie bracket and shaft if they are cracked or damaged. Replace the bearing and grease seal if the bearing is pitted, cracked, discolored, or worn. To replace the bearing remove the inner bearing from the bogie shaft with a standard puller. Remove the inner grease seal from the bogie shaft. To install the grease seal and bearing, use a KRW-M8-308A bearing driver.

(2) **SPRING SEAT BRACKET.** Replace the spring seat bracket if it is cracked or damaged. Examine the inner and outer bearing cups for cracks, pits or wear. If any of these conditions exist, replace the cups. Remove the inner and outer bearing cup from the spring seat bracket, using a suitable puller. To install, press the bearing cups in the spring seat bracket.

e. **Assemble** (fig. 84). Lubricate the bogie bearings with specified grease. Install the spring seat bracket on the bogie shaft. Slide the outer bearing into the spring seat bracket. Install the spacer washer and adjusting nut. Run the adjusting nut up tight, then back it off  $\frac{1}{8}$  turn. This establishes the correct bearing adjustment. Install the

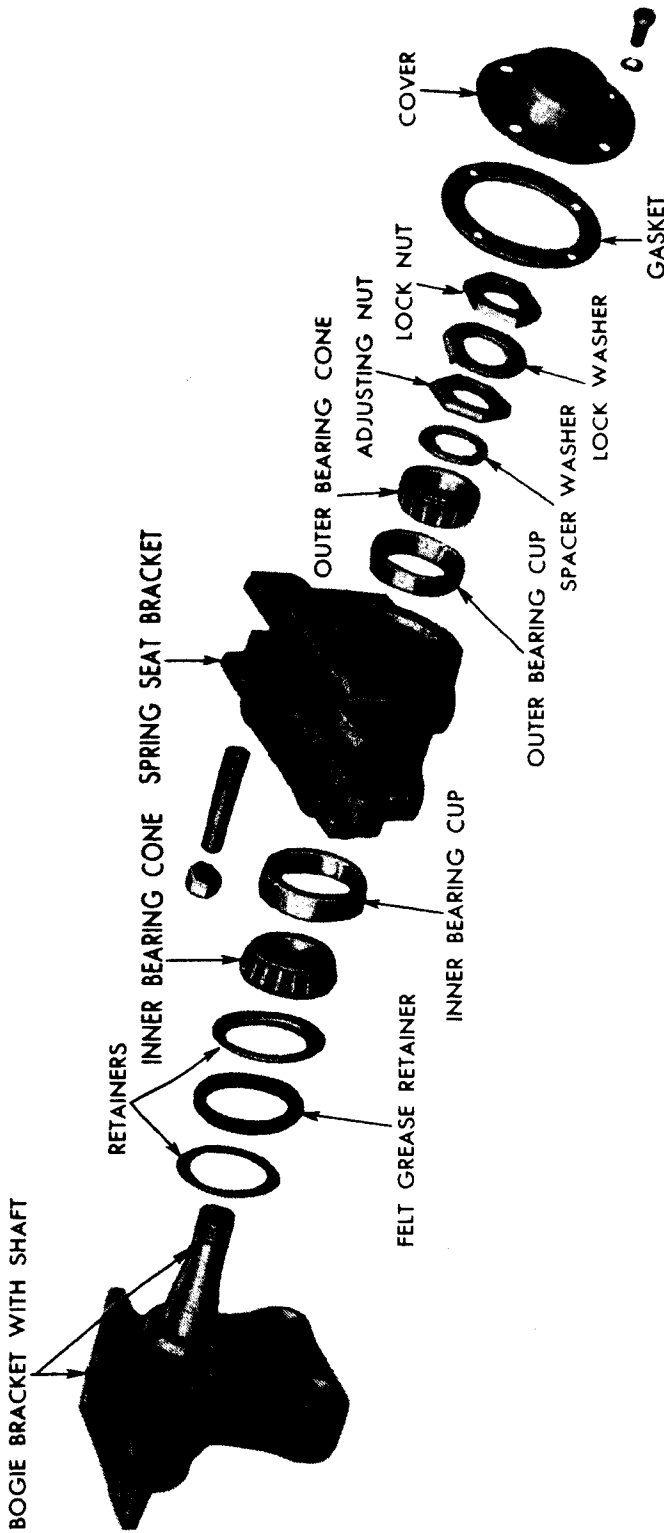
ORDNANCE MAINTENANCE—POWER TRAIN, SUSPENSION, HULL,  
AND TURRET FOR ARMORED CAR M8 AND UTILITY CAR M20



RA PD 28427

Figure 83—Bogie Assembly

**BOGIE, SPRINGS, SHACKLES, AND SHOCK ABSORBERS**



RA PD 28428

**Figure 84—Bogie, Disassembled**

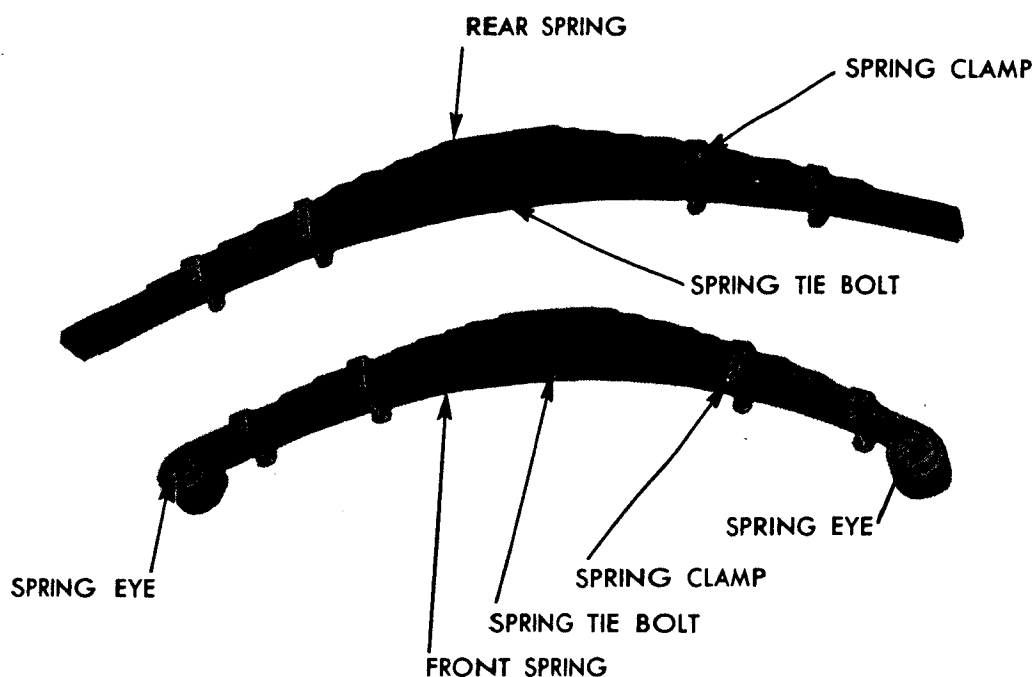
**TM 9-1743**  
**95-96**

**ORDNANCE MAINTENANCE—POWER TRAIN, SUSPENSION, HULL,  
AND TURRET FOR ARMORED CAR M8 AND UTILITY CAR M20**

lock washer and outer nut. Tighten the outer nut and bend the tabs on the lock washer down to lock the nut. Install the gasket and bogie bearing cover, and secure with four cap screws.

**96. SPRINGS (fig. 85).**

a. **Description.** The two front springs are of the semielliptical type and consist of 11 leaves each. The top leaf has an eye formed at each end for the shackle bolt. The two rear springs are of the semielliptical type and consist of 12 leaves each.



**RA PD 28429**

**Figure 85—Front and Rear Springs**

b. **Disassemble (fig. 85).** Place the spring in a vise equipped with brass jaws. Remove the spring tie bolt. Remove the four spring clamp nuts and bolts. Remove the spring from the vise and separate the leaves.

c. **Clean.** Wash the spring leaves with dry-cleaning solvent and dry with a cloth or compressed air.

d. **Inspect and Repair.** Examine each spring leaf for cracks, breaks, or excessive wear. If any of these conditions exist, replace the leaves.

e. **Assemble (fig. 85).** Place the spring leaves together and aline the holes for the spring tie bolt. Place the spring leaves in a vise or

## BOGIE, SPRINGS, SHACKLES, AND SHOCK ABSORBERS

clamp and compress the leaves. Install the spring tie bolt and nut. Tighten the tie bolt nut securely. Install the four spring clamp bolts and nuts. Tighten the spring clamp nuts, and remove the spring from the vise.

### 97. SHACKLES (fig. 86).

a. Two spring shackles are used, one at the rear end of each front spring. Wash the shackles with dry-cleaning solvent, and dry with a cloth or compressed air. Inspect the spring shackles and shackle bolts for cracks, wear, or damage. If any of these conditions exist, replace the shackles and shackle bolts.

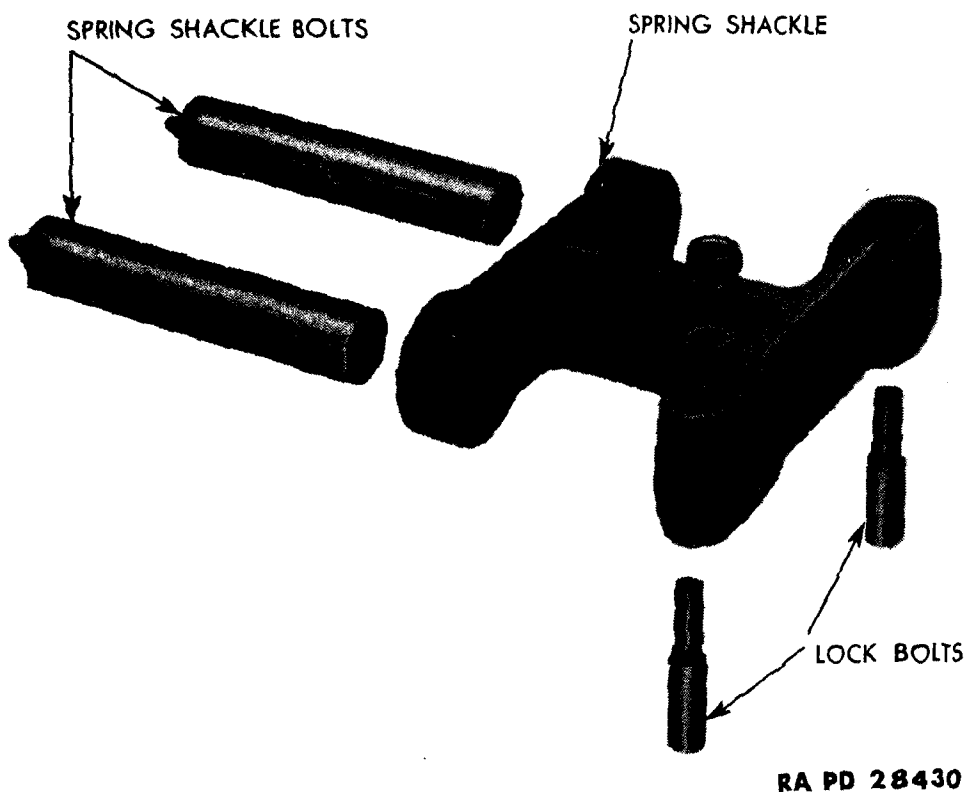


Figure 86—Spring Shackle and Bolts

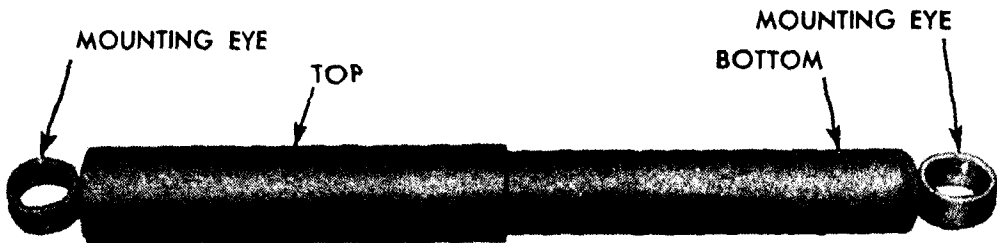
### 98. SHOCK ABSORBERS (fig. 87).

a. **General.** The vehicle is equipped with six Gabriel direct-acting shock absorbers, one on both sides of each axle. Wash the shock absorber with dry-cleaning solvent, and dry with a cloth. If the shock absorber is cracked, worn excessively, or is leaking fluid, it must be replaced.

b. **Adjust.** Push the unit together to engage the adjusting key. With the key engaged, turn the lower half of the shock absorber clock-



**ORDNANCE MAINTENANCE—POWER TRAIN, SUSPENSION, HULL,  
AND TURRET FOR ARMORED CAR M8 AND UTILITY CAR M20**



RA PD 28431

**Figure 87—Shock Absorber**

wise until the limit of the adjustment is reached. Holding the unit together to keep the adjusting key still in the slot, turn the lower end of the shock absorber back (counterclockwise) two turns. This will establish the average adjustment. Turning the adjustment to the right (clockwise) gives a firmer control for rough terrain, turning the adjustment counterclockwise establishes a softer control.

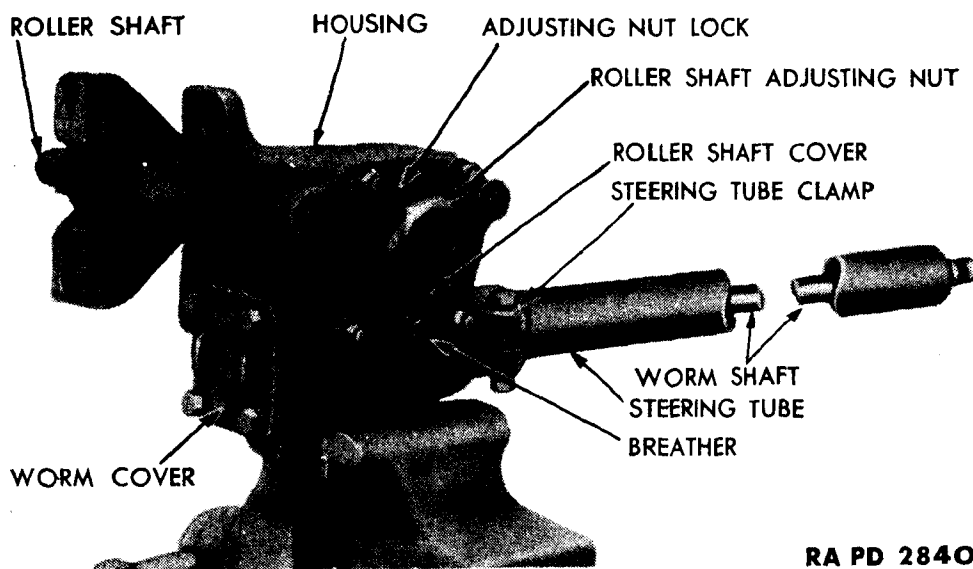
## CHAPTER 8

### STEERING GEAR

	Paragraph
Description and data.....	99
Disassembly .....	100
Cleaning, inspection and repair.....	101
Assembly and adjustment.....	102

#### 99. DESCRIPTION AND DATA.

a. The steering gear is a Gemmer model 400 and is of the hour glass worm and roller type with a reduction ratio of 24.4 to 1. The worm is mounted on two tapered roller bearings, the steering shaft



RA PD 28402

**Figure 88—Steering Gear Assembly**

roller is mounted on a needle roller bearing. The upper part of the worm shaft is supported in the steering tube by a self-aligning ball bearing. Oil seals are provided in the housing to prevent lubricant from leaking out at the worm shaft and the roller shaft. The roller shaft is provided with replaceable type bushings which are pressed in the housing.

#### 100. DISASSEMBLY.

a. **Remove Roller Shaft.** Place the steering gear in a vise as shown in figure 88. Note that the assembly is held in the vise by a lug provided on the housing for this purpose. Remove the four nuts from the roller shaft cover studs. Remove the lock plate and bushing. Remove the adjusting nut and the two halves of the roller shaft thrust

ORDNANCE MAINTENANCE—POWER TRAIN, SUSPENSION, HULL,  
AND TURRET FOR ARMORED CAR M8 AND UTILITY CAR M20

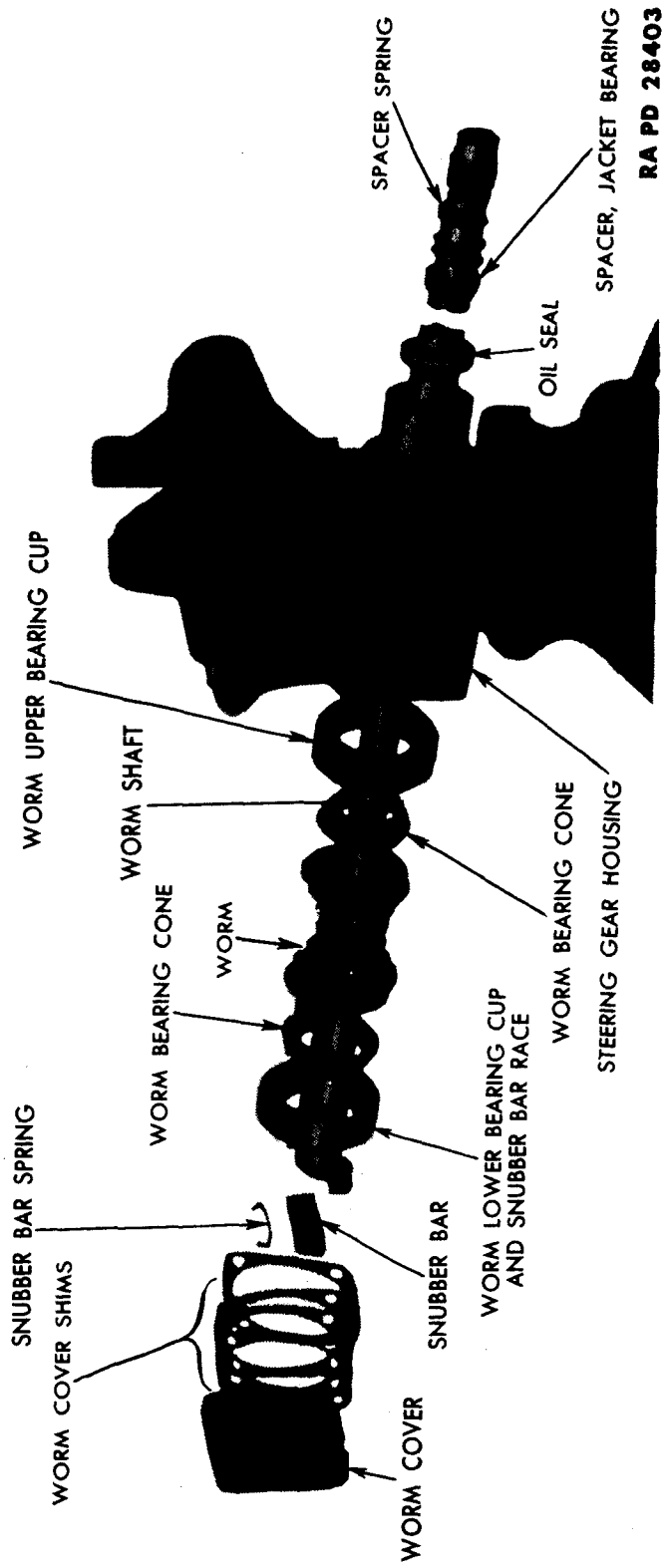
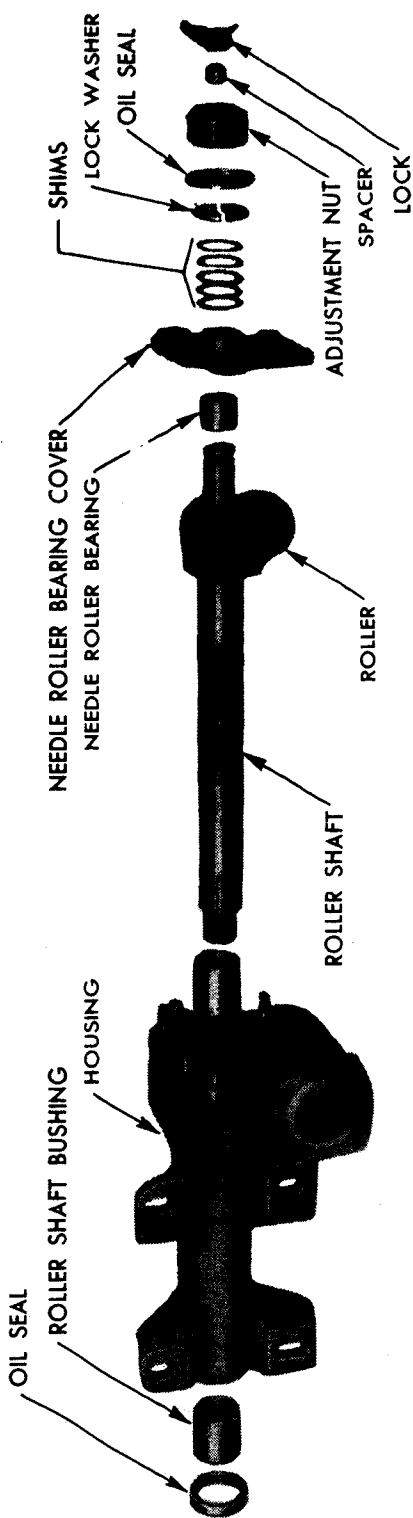


Figure 89—Steering Worm and Shaft, Disassembled

STEERING GEAR



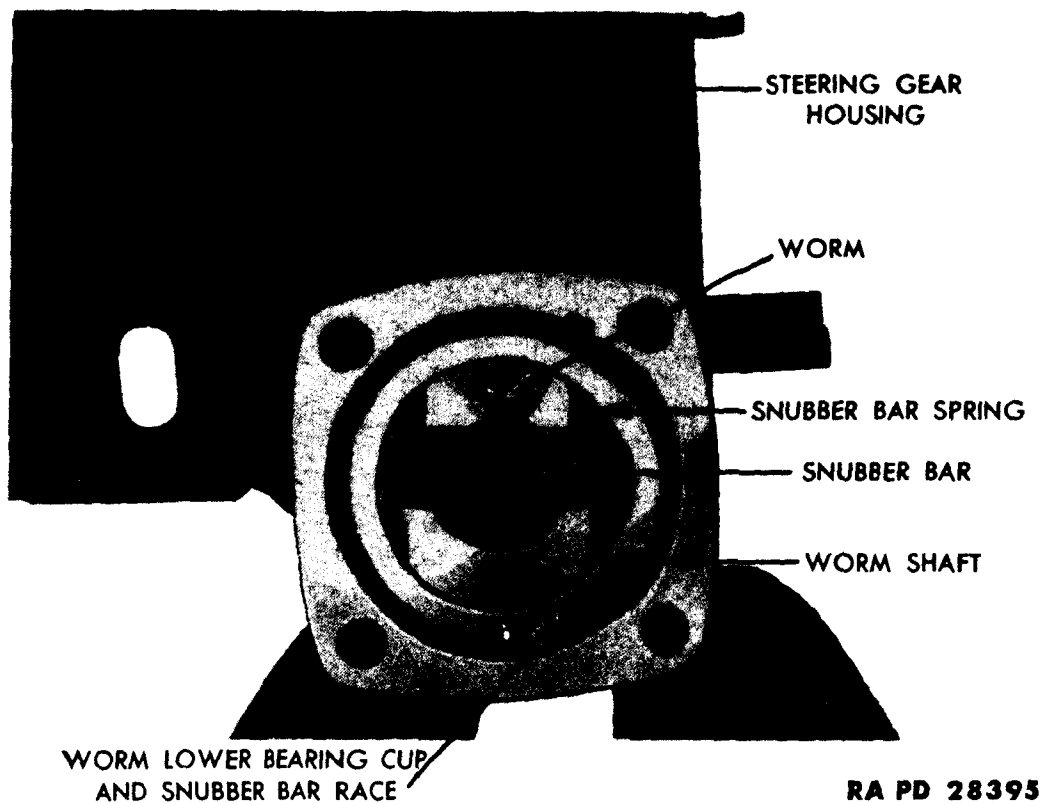
RA PD 28404

Figure 90—Roller Shaft Assembly, Disassembled

**ORDNANCE MAINTENANCE—POWER TRAIN, SUSPENSION, HULL,  
AND TURRET FOR ARMORED CAR M8 AND UTILITY CAR M20**

washer and the shims, noting the number of shims removed. Remove the roller shaft cover. Pull the roller shaft from the housing.

b. **Remove Worm and Main Shaft.** Loosen the clamp bolt on the steering tube (fig. 88) and remove the tube. Remove the four cap screws from the worm cover. Remove the cover and the shims (fig. 90), noting the number of shims removed. Tap the worm out of the housing until the snubber bar (fig. 91) is free. Remove the snubber bar and the worm shaft from the housing. Tap the worm until the



RA PD 28395

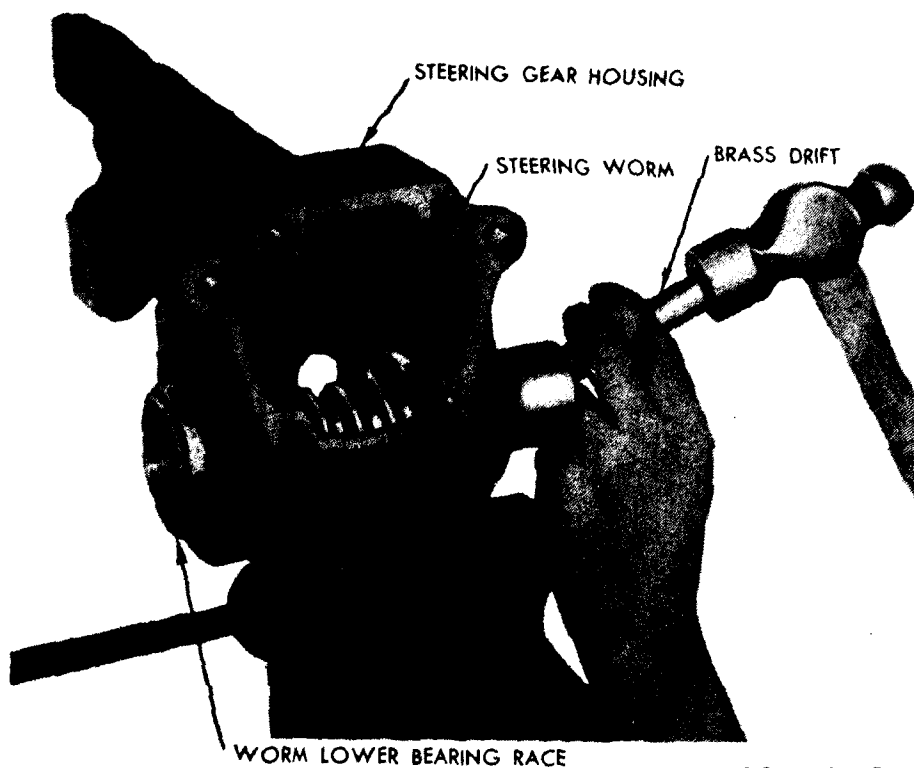
**Figure 91—Snubber Bar and Spring**

worm lower bearing race is free from the housing (fig. 92). Remove the race and roller bearing cage. Pull the worm out of the housing and remove the upper roller bearing cage.

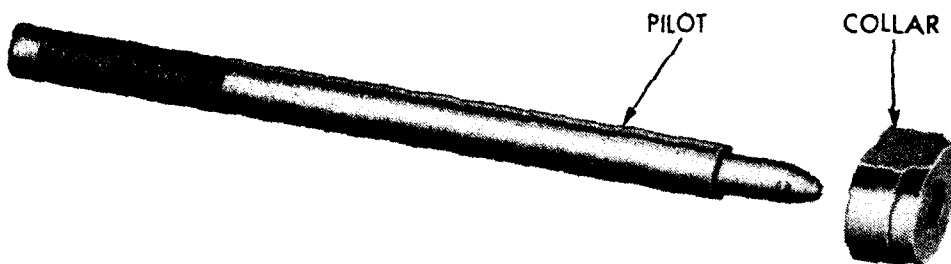
**101. CLEANING, INSPECTION AND REPAIR.**

a. **Steering Roller Shaft.** Wash roller shaft in dry-cleaning solvent. Examine the roller for cracks and scores. Rotate the roller and check for excessive play and roughness. Examine the shaft for out-of-round and excessive wear. If any of the above faults are present, replace the roller shaft assembly.

## STEERING GEAR



**Figure 92—Removing Worm Lower Bearing Race**



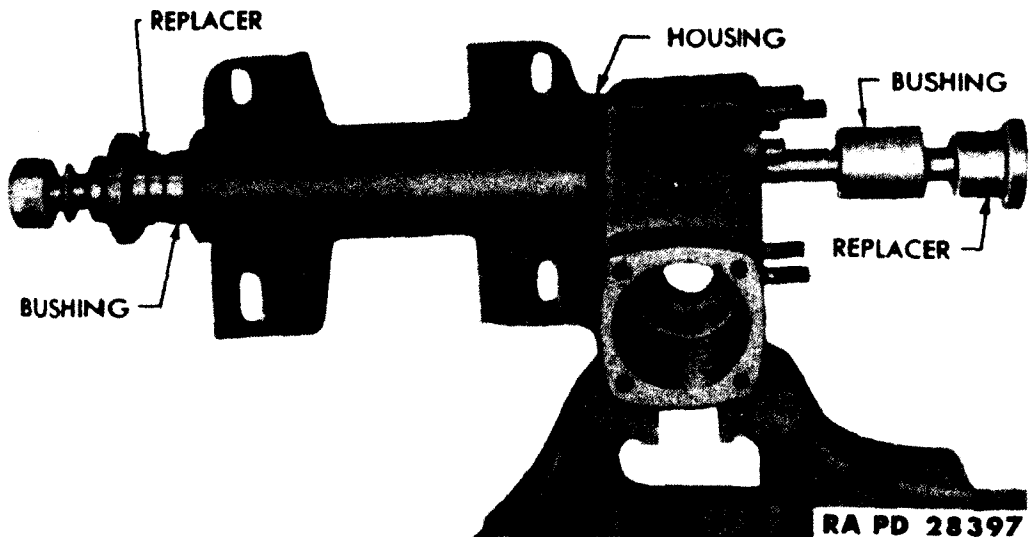
**Figure 93—Remover 41-R-2384-177 Used for Removal of Roller Shaft Bushings**

### b. Steering Housing and Roller Shaft Cover.

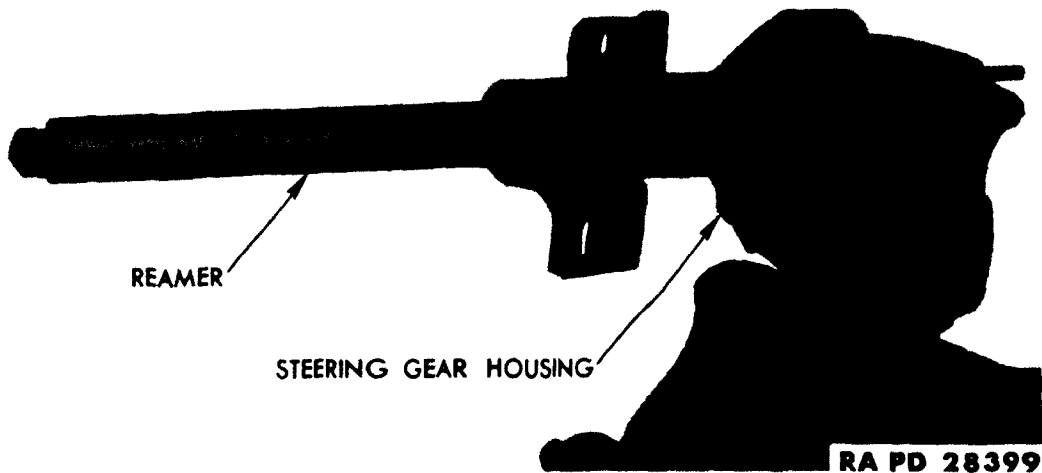
(1) **CLEAN AND INSPECT.** Remove the roller shaft and the worm shaft oil seals. Wash housing and roller shaft cover in dry-cleaning solvent. Replace the housing if cracked or damaged. Insert the roller shaft in place in the housing and check wear of the roller shaft bushings, using the roller shaft as a gage. The original clearance between

**ORDNANCE MAINTENANCE—POWER TRAIN, SUSPENSION, HULL,  
AND TURRET FOR ARMORED CAR M8 AND UTILITY CAR M20**

the roller shaft and the bushings was 0.002 inch; if the wear is more than 0.010 inch, replace the bushings (step (2) below). Examine the worm upper and lower bearing cups (fig. 89). If they are scored, cracked or excessively worn, they must be replaced (step (4) below).



**Figure 94—Replacer 41-R-2396-100 for Installing  
Roller Shaft Bushings**



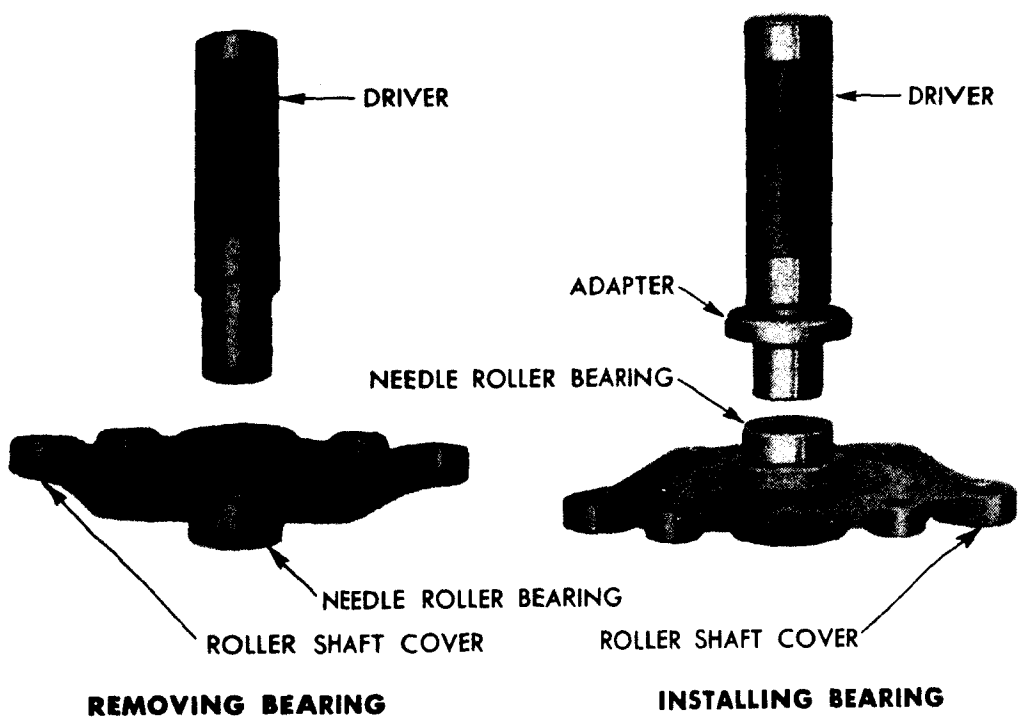
**Figure 95—Reaming Roller Shaft Bushings, using  
Reamer 41-R-905-150**

Examine the roller shaft cover needle roller bearing (fig. 90). If the needle rollers are rough or there is excessive play between the bearing and shaft, replace the bearing (par. 101 b (3)). Install the roller shaft oil seal, using tool as shown in figure 98. Install the worm shaft oil seal, using tool as shown in figure 99.

### STEERING GEAR

(2) **BUSHING REPLACEMENT.** To remove the bushings, use tool shown in figure 93. Slide collar through one bushing so that it is between the bushings. Enter the pilot through the hole in the collar, and drive out the inner bushing. Reverse the tool and drive out the outer bushing. To install the bushings, use tool as shown in figure 94. Ream the bushings to size, using tool as shown in figure 95.

(3) **ROLLER SHAFT COVER NEEDLE ROLLER BEARING REPLACEMENT.** To remove or install the roller shaft cover needle roller bearing, use tool as shown in figure 96.



RA PD 28400,

**Figure 96—Remover and Replacer 41-R-2389-33 for Removing and Installing Roller Shaft Cover Needle Roller Bearing**

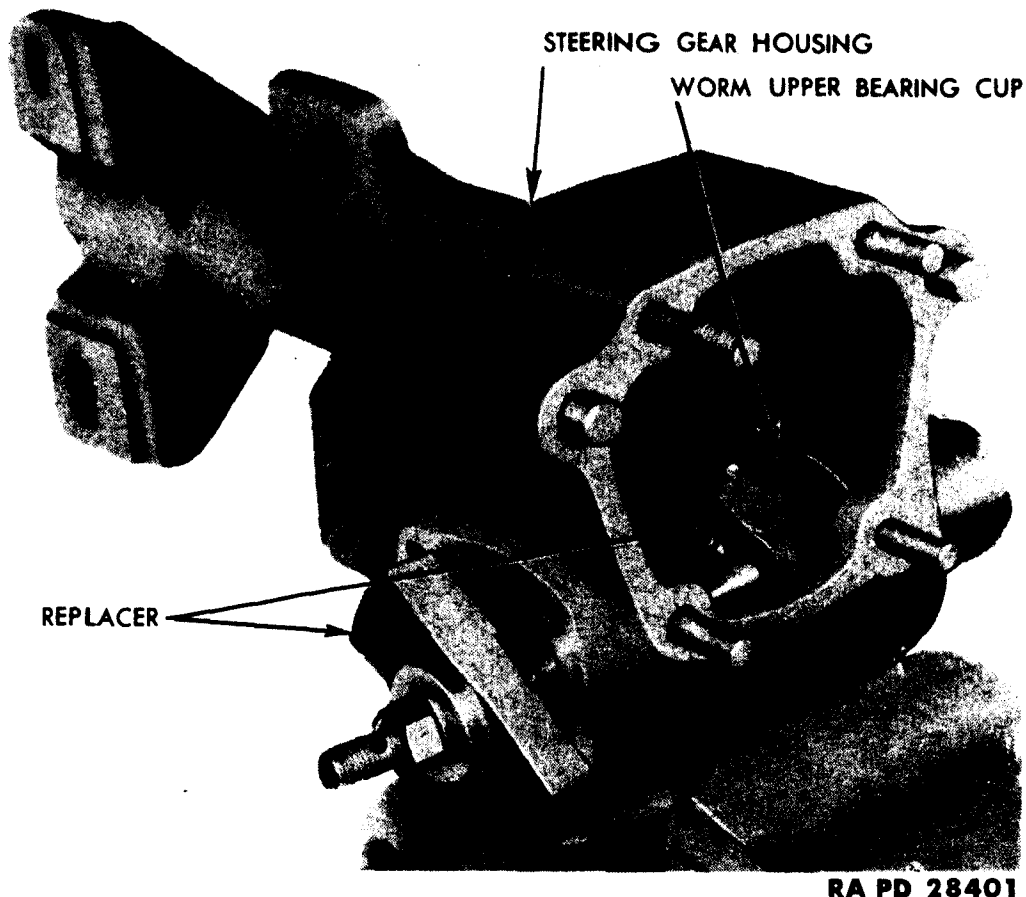
(4) **WORM UPPER BEARING CUP REPLACEMENT.** To remove the worm upper bearing cup, use tool as shown in figure 97. To install the bearing cup, use tool as shown in figure 99.

c. **Steering Worm and Lower Bearing Race, Bearing Carriers, Snubber Bar and Jacket Bearing.** Wash all parts in dry-cleaning solvent. If worm or lower bearing race (fig. 89) is scored or shows excessive wear, it must be replaced. If rollers in the roller bearings (fig. 89) are scored or show excessive wear, they must be replaced. Replace the snubber bar (fig. 91) if it shows excessive wear. Rotate jacket ball bearing inside steering column; if it feels rough replace steering tube.

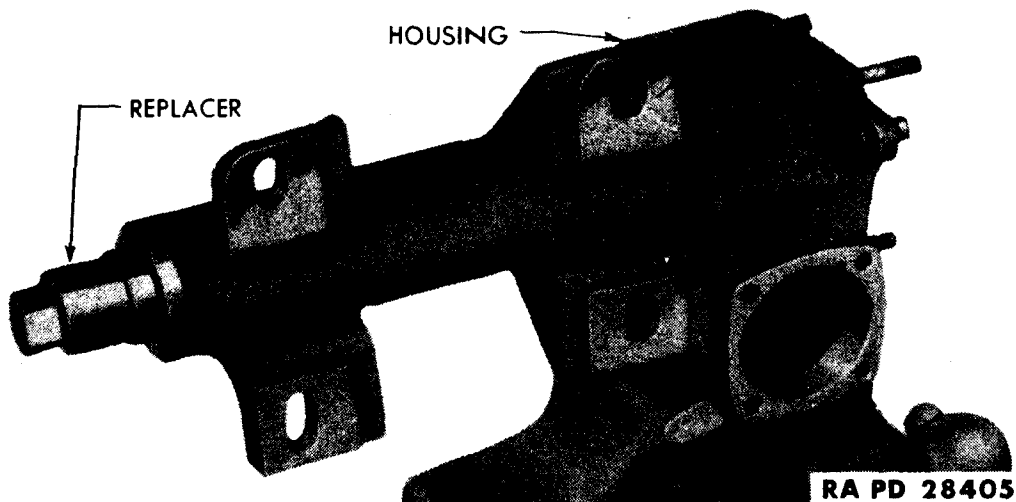


**TM 9-1743**  
**101**

**ORDNANCE MAINTENANCE—POWER TRAIN, SUSPENSION, HULL,  
AND TURRET FOR ARMORED CAR M8 AND UTILITY CAR M20**



**Figure 97—Removing Worm Upper Bearing Cup with  
Replacer 41-R-2395-110**

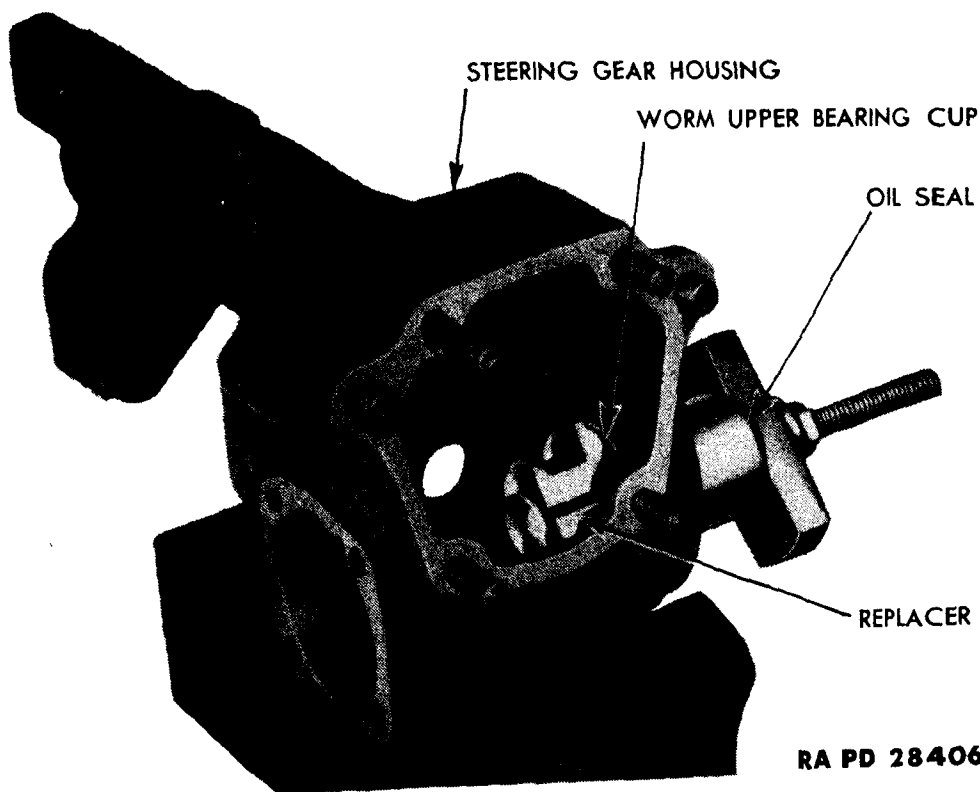


**Figure 98—Installing Roller Shaft Oil Seal with  
Replacer 41-R-2396-100**

## STEERING GEAR

### 102. ASSEMBLY AND ADJUSTMENT.

a. **Assemble Worm and Main Shaft.** Place the housing in a vise (fig. 88). Coat the two worm roller bearing cages with universal gear lubricant. Place the upper roller bearing on the worm, and insert the worm in the housing. Place the lower roller bearing on the worm, and tap the lower roller bearing race into the housing. Insert the main shaft in the worm until the lug on the end of the shaft is flush with the worm lower bearing race. In order to eliminate friction while checking the bearing clearance, it will be necessary to make a "dummy" snubber block of wood and insert it temporarily in place between the lugs of the worm and the shaft instead of the metal snubber bar and spring as shown in figure 91. Install the worm cover with shims.



**Figure 99—Installing Worm Upper Bearing Cup and Oil Seal with Replacer 41-R-2395-110**

b. **Adjust Worm Shaft Bearing.** The shaft should turn with slight finger pressure. Two thicknesses of shims are used to permit close adjustment. If the shaft does not turn with finger pressure, it will be necessary to add a shim. If the shaft turns too freely, remove a shim. Approximately  $\frac{1}{16}$  inch end play will be noted in the steering shaft. This play is normal and is taken up by the spring in the bearing at upper part of shaft when the steering wheel is installed.

**ORDNANCE MAINTENANCE—POWER TRAIN, SUSPENSION, HULL,  
AND TURRET FOR ARMORED CAR M8 AND UTILITY CAR M20**

c. **Assemble Roller Shaft.** Coat the roller shaft bushings lightly with universal gear lubricant. Insert the roller shaft through the bushings into the housing. Install the roller shaft cover. Install the shims and the two halves of the thrust washer. Install the seal and the adjusting nut. Install the steering wheel temporarily on the splines of the steering shaft.

d. **Adjust Roller to Worm Mesh.** Turn wheel until stop is reached, then turn back  $3\frac{1}{2}$  turns. This will bring the roller in the center of the worm. With hand pressure on the shaft and the roller in the center of the worm, a slight drag should be noticeable for approximately  $\frac{1}{2}$  turn. Two thicknesses of shims are used to permit close adjustment. If no drag is noticeable, add a shim. If too much drag is present, remove a shim.

e. **Assemble Steering Tube and Snubber Bar.** Assemble steering tube and tighten clamp (fig. 88). Remove worm cover and replace "dummy" snubber bar with the standard snubber bar and spring (fig. 91). Install the worm cover. Fill the steering gear to the recommended level with specified lubricant.

## CHAPTER 9 BRAKES AND HUBS

	Paragraph
Description and data .....	103
Brake shoes .....	104
Brake drums .....	105
Brake master cylinder .....	106
Brake slave cylinders .....	107
Hubs .....	108

### 103. DESCRIPTION AND DATA.

a. **Description.** A hydraulically operated, two-shoe, internal expanding brake (fig. 101), is provided at each of the six wheels. The pressure applied to the brake pedal is boosted by means of a hydrovac booster. Each brake assembly has two slave cylinders, thus making each shoe a primary shoe.

b. **Data.**

Diameter of wheel cylinders:

Front .....	1½ in.
Intermediate .....	1½ in.
Rear .....	1½ in.
Adjustment .....	Adjusting screw
Diameter of brakes .....	15 in.
Width of lining .....	1¼ in.
Thickness of lining .....	0.4 in.
Length of lining per shoe .....	15⅞ in.
Total brake area .....	429 sq in.

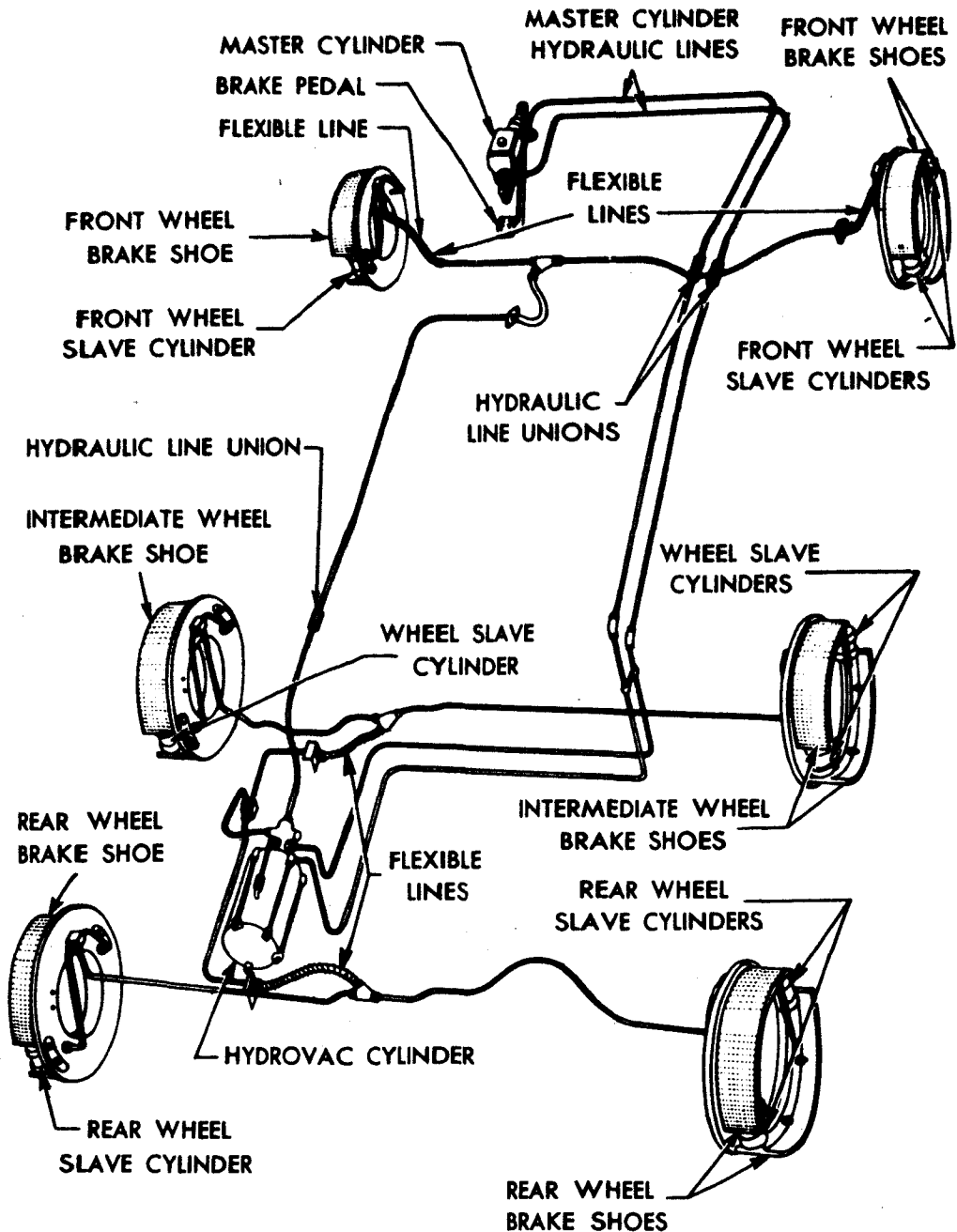
### 104. BRAKE SHOES.

a. Remove the lining and clean the brake shoes with dry-cleaning solvent and a wire buffer. Discard brake shoes that are distorted or that have broken welds. Install new lining on the shoes, riveting the two center holes. Use a brake shoe lining clamp to force the lining against the shoe. After the end holes in the lining and shoe are in alinement, install the rivets in both ends. Remove the clamp and install the balance of the rivets.

### 105. BRAKE DRUMS.

a. Clean the brake drums with a dry-cleaning solvent. Cracked brake drums will be discarded. Scored brake drums or drums badly

**ORDNANCE MAINTENANCE—POWER TRAIN, SUSPENSION, HULL,  
AND TURRET FOR ARMORED CAR M8 AND UTILITY CAR M20**

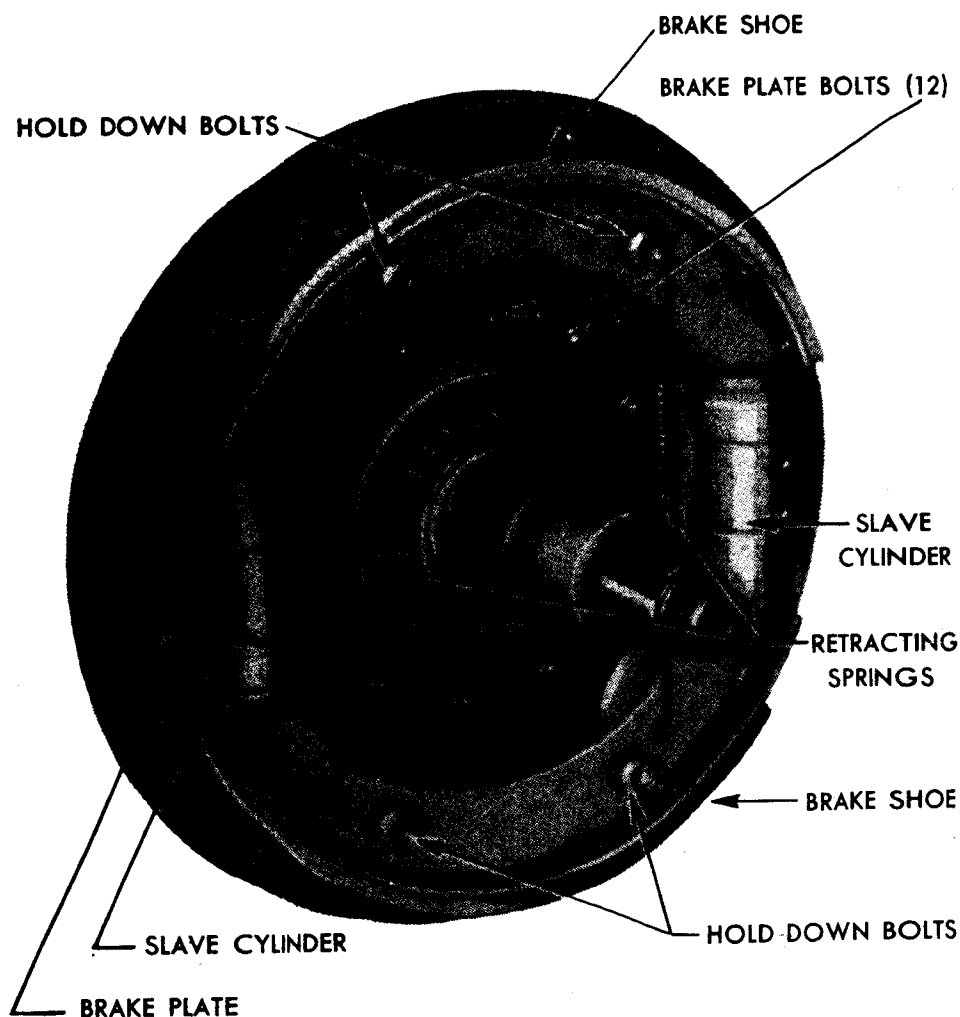


RA PD 28394

**Figure 100—Brake System**

### BRAKES AND HUBS

worn will be reworked in a brake drum lathe. Turn the brake drum down on the lathe until all evidence of the scores are removed. Brake drums that do not clean up at a diameter of 15.060 inches or less must be discarded.



RA PD 28441

**Figure 101—Brake Plate Assembly**

#### 106. BRAKE MASTER CYLINDER (fig. 102).

a. **Disassemble.** Slip the boot retainer rings back onto the boot and pull the boot and pedal rod off the master cylinder as an assembly. Slip the two boot retainer rings off the boot. Slip the pedal rod out of the boot. Remove the master cylinder outlet fitting bolt and fitting. Place the master cylinder in a vise. Lift the lock ring from the

ORDNANCE MAINTENANCE—POWER TRAIN, SUSPENSION, HULL,  
AND TURRET FOR ARMORED CAR M8 AND UTILITY CAR M20

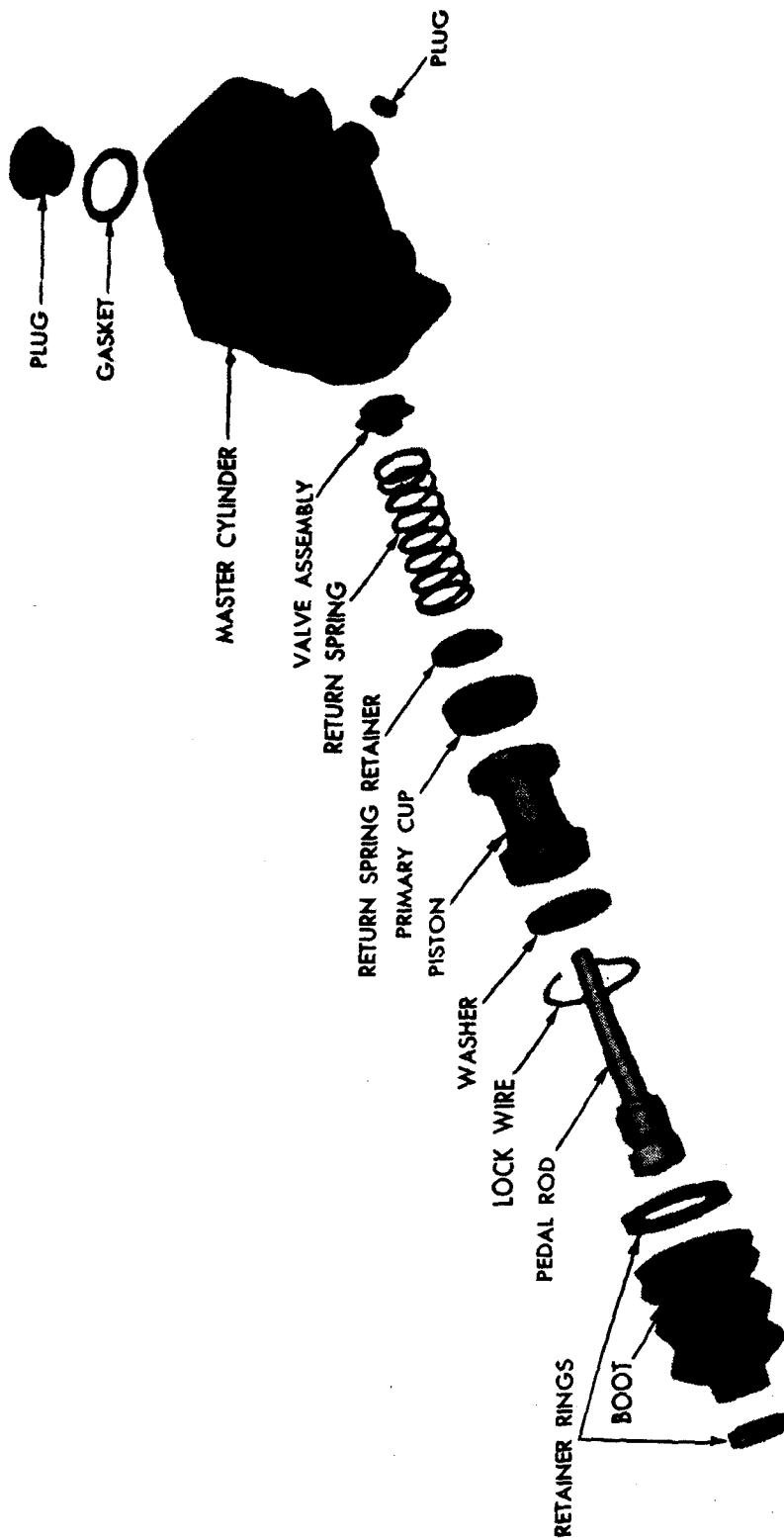


Figure 102—Brake Master Cylinder, Disassembled

BRAKES AND HUBS

RA PD 28433

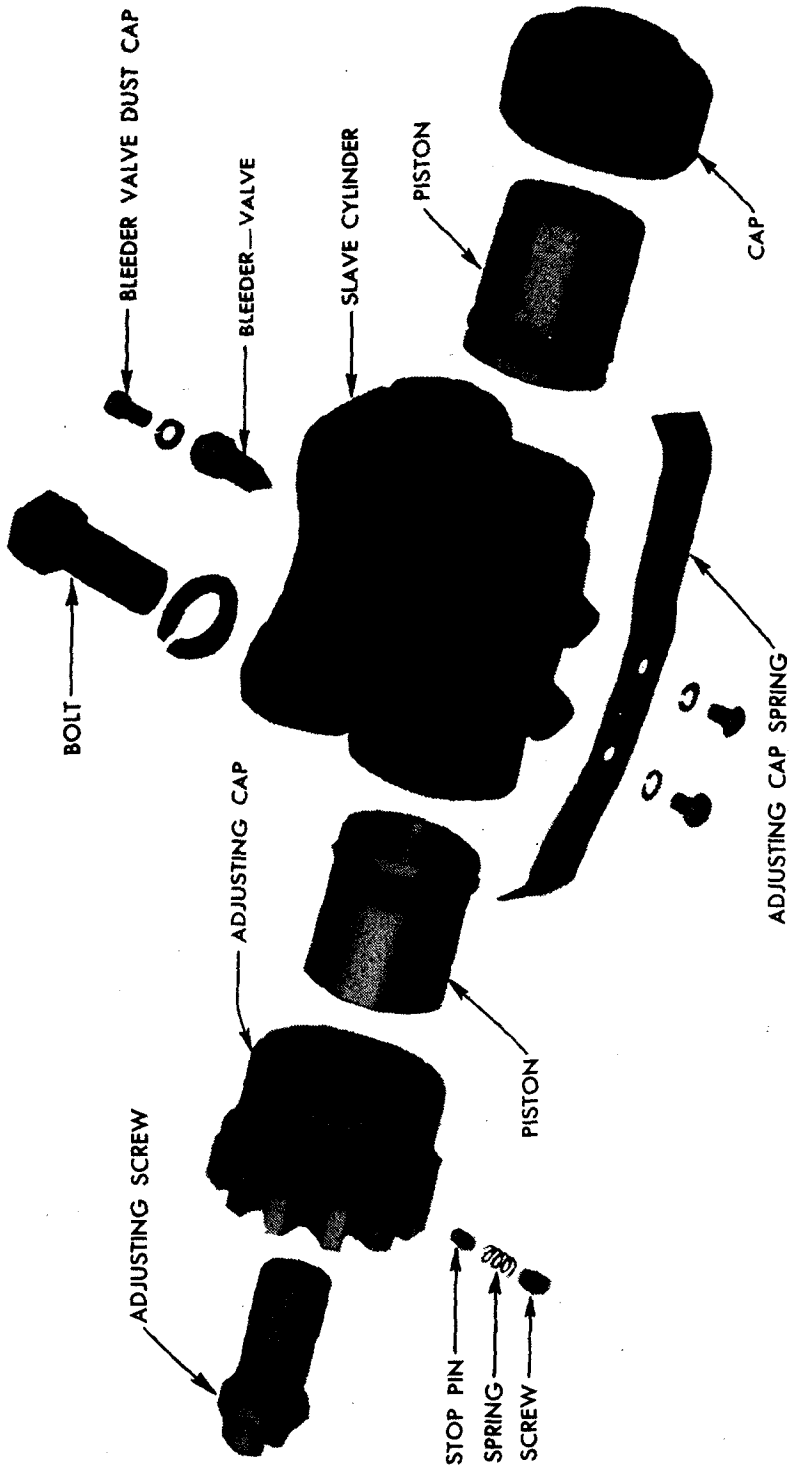


Figure 103—Slave Cylinder, Disassembled



**ORDNANCE MAINTENANCE—POWER TRAIN, SUSPENSION, HULL,  
AND TURRET FOR ARMORED CAR M8 AND UTILITY CAR M20**

master cylinder with a screwdriver. Lift the flat washer and piston from the cylinder. Using a blunt tool or rod, push the primary cup, return spring retainer, and the valve assembly from the cylinder. Pull the return spring off the valve.

b. **Clean and Inspect.** Wash all master cylinder parts in clean denatured alcohol. Scored or badly worn pistons or cylinders must be discarded. Discard any rubber parts that are torn or swollen.

c. **Assemble.** Press the valve into the return spring, making sure the brass tabs on the valve are locked on the return spring. Dip all parts in clean hydraulic brake fluid. Place the valve and spring assembly in the cylinder. Install the primary cup in the cylinder with the flat side facing up. Install the piston in the cylinder with the secondary cup toward the top. Place the washer on top of the piston. Press down on the washer and install the lock ring in the groove provided in the cylinder. Slip the pedal rod into the small end of the boot and install the boot retainer ring over the boot. Slip the boot retainer ring onto the boot. Slip the boot onto the master cylinder and install boot retainer ring in place. Using a new copper gasket on each side of the outlet fitting, install the fitting and bolt in the master cylinder.

**107. BRAKE SLAVE CYLINDERS (fig. 103).**

a. **Disassemble.** Slip the two caps off the slave cylinder. Press on one piston until the opposite piston comes out. Press the other piston out of the cylinder. Remove the bleeder valve dust cap, washer, and bleeder valve.

b. **Clean and Inspect.** Wash all slave cylinder parts in clean denatured alcohol. Cylinders or pistons found scored or badly worn must be discarded. Swollen or damaged rubber parts must be replaced.

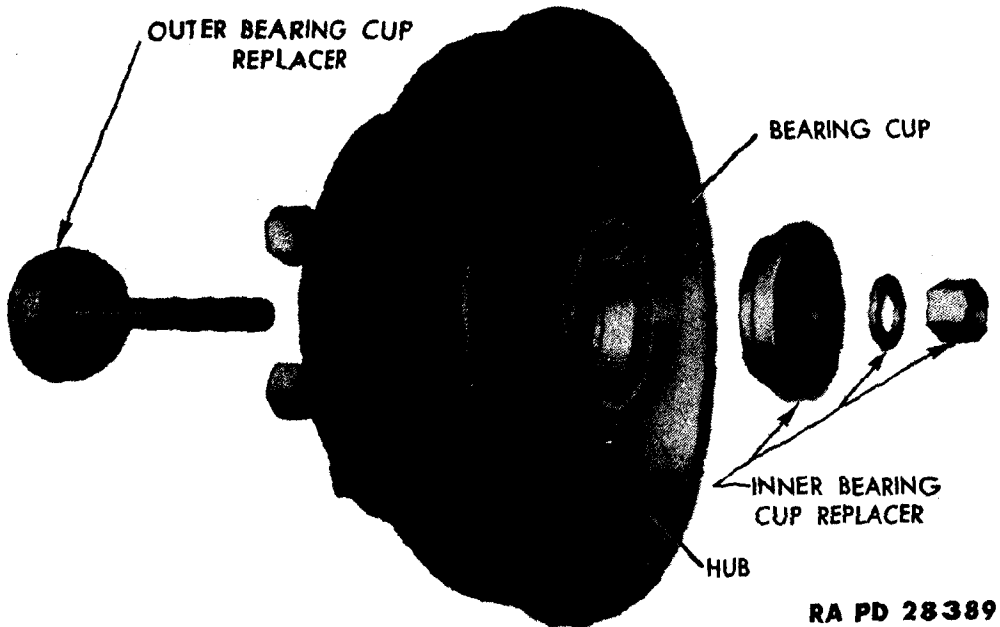
c. **Assemble.** Install the two pistons in the cylinder with the surfaces facing each other. Slip the cap onto the cylinder to line up with the indentation in spring retainer. Slip the cap on the other end of the cylinder. Install bleeder valve, lock washer, and dust cap in the slave cylinder.

**108. HUBS.**

a. **Clean and Inspect.** Clean the hub with dry-cleaning solvent. Inspect the hubs for stripped or damaged studs, and worn, cracked or ridged bearing cups. Damaged studs or defective bearing cups must be replaced.

### BRAKES AND HUBS

b. **Stud Replacement.** Remove the lock nut that holds the stud in the hub. Using a brass driver, tap the stud out of the hub. Line the new stud up with the flange on the brake drum hub and tap the stud in place with a brass hammer. Install and tighten the lock nut.



**Figure 104—Replacer 41-R-2394-108 for Installing Bearing Cups in Hub**

c. **Bearing Cup Replacement.** Remove the bearing cup from the hub, using a brass drift. Install the new bearing cup into the hub, using bearing cup replacer (41-R-2394-108) (fig. 104).

ORDNANCE MAINTENANCE—POWER TRAIN, SUSPENSION, HULL, AND TURRET FOR ARMORED CAR M8 AND UTILITY CAR M20

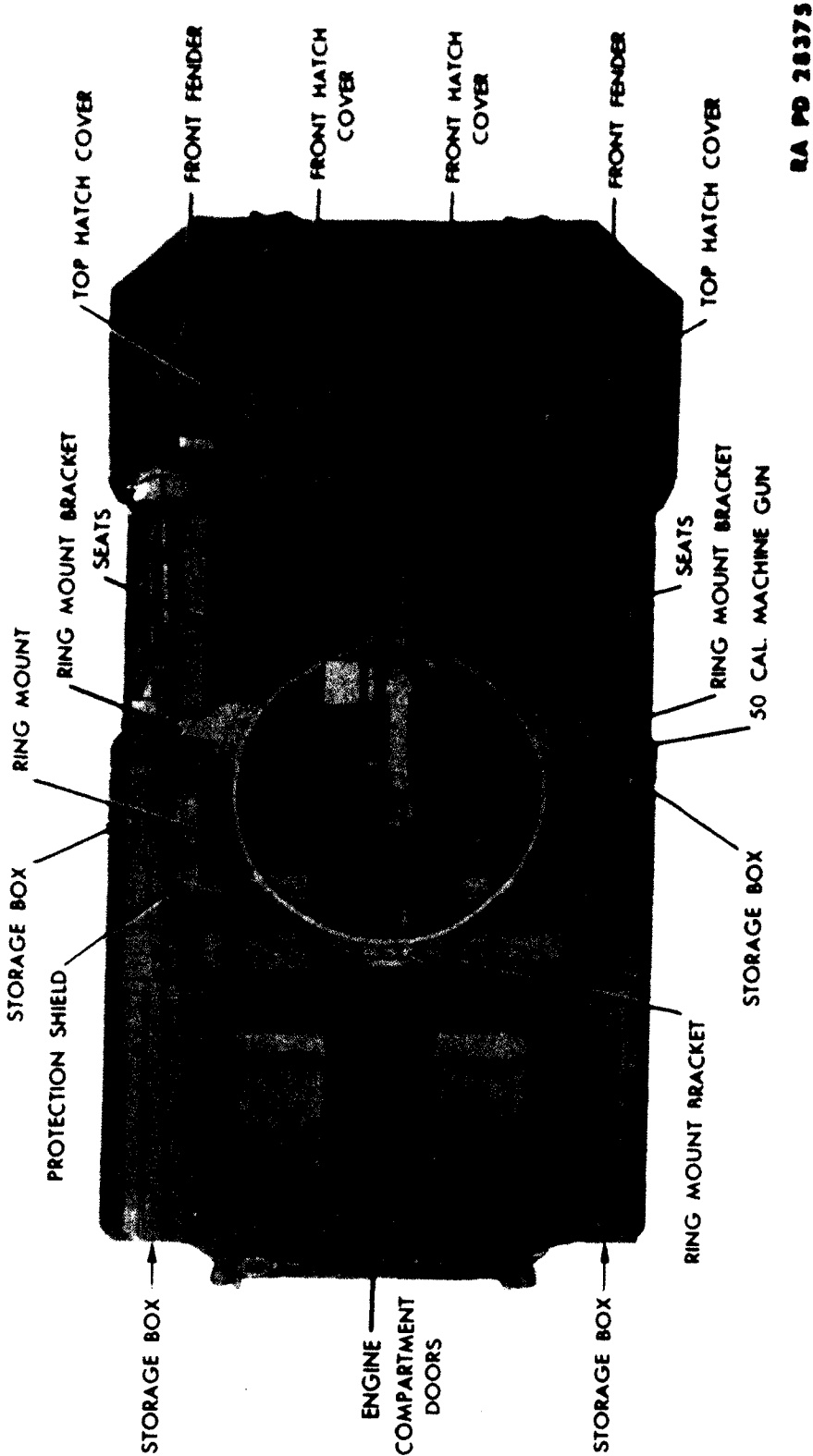


Figure 105—View of M20 from Above

## CHAPTER 10 HULL AND TURRET

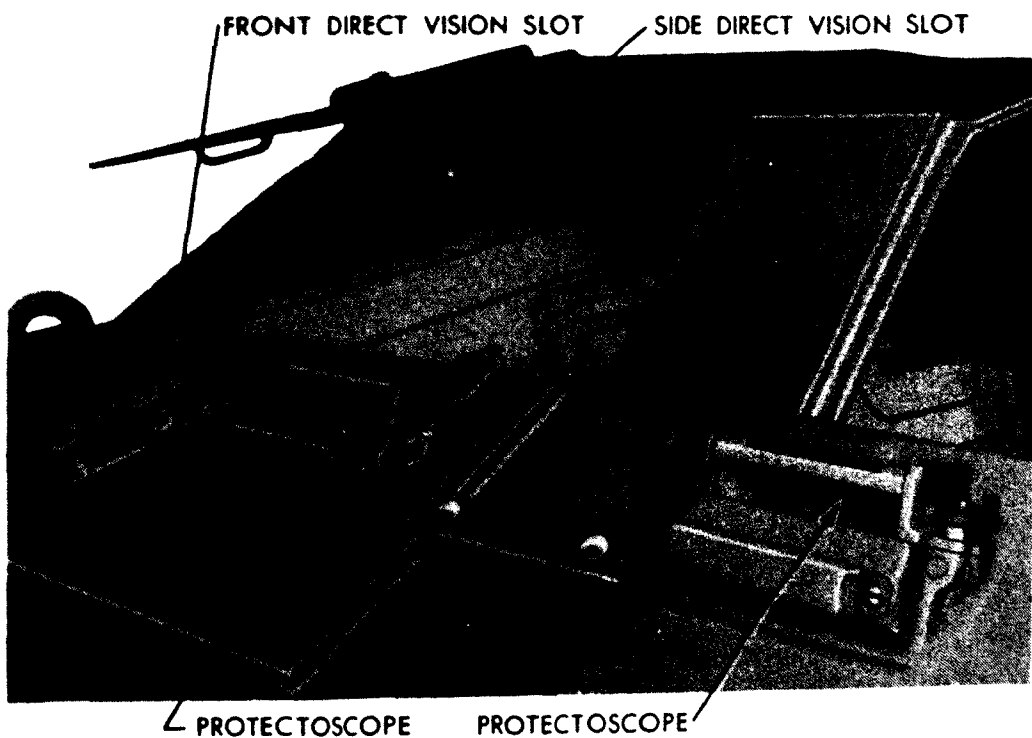
### Section I

### DESCRIPTION

	Paragraph
General description .....	109
Differences between M8 and M20 .....	110

#### 109. GENERAL DESCRIPTION.

a. **Hull.** The armor plate hull of the M8 and M20 armored cars is of all-welded construction. The front armor plate is  $\frac{3}{4}$ -inch,  $\frac{5}{8}$ -inch and  $\frac{1}{2}$ -inch thick, the thickness varying according to the inclination of the plate. The sides are  $\frac{3}{8}$ -inch thick. The driver's and assistant driver's hatch top covers are  $\frac{1}{4}$ -inch armor plate, the hatch front



RA PD 28373

**Figure 106—Direct Vision Slots and Protectoscope**

covers are  $\frac{3}{4}$ -inch armor plate (fig. 105). The engine compartment covers are  $\frac{1}{4}$ -inch armor plate.

b. **Vision Devices** (fig. 106). Direct vision slots are provided on the front and on the side of the hatch covers in the driver's and assistant driver's compartment. Shutters are provided for each slot

**ORDNANCE MAINTENANCE—POWER TRAIN, SUSPENSION, HULL,  
AND TURRET FOR ARMORED CAR M8 AND UTILITY CAR M20**

with controlled handles on the inside. Two protectoscope slots fitted with protectoscopes are also provided, one in each front hatch cover.

c. **Hatch Covers and Engine Compartment Doors.** The hatch front and top covers over the driver and assistant driver can be tipped forward and sidewise respectively to gain access to these compartments. When not in combat, these hatch covers may be left open. The engine compartment is provided with two hinged doors (fig. 105).

d. **Fenders and External Boxes.** External boxes of sheet metal are provided for storage of supplies. These boxes are integral with



**RA PD 28434**

**Figure 107—Pintle Hook**

the rear fender. The front and rear fenders and the storage boxes are bolted to the hull.

e. **Pintle Hook** (fig. 107). A pintle hook of the quick release type is provided on the rear of the vehicle.

**110. DIFFERENCES BETWEEN M8 AND M20.**

a. **Turret, M8** (fig. 112). The turret is of cast steel 0.7-inch thick. The turret can be traversed through 360 degrees by a hand-operated gear mechanism. The turret is supported by three support rollers.

**DESCRIPTION**

Lateral and vertical motion of the turret is prevented by means of hold-down rollers. The M8 is equipped with a 37-mm gun.

**b. Ring Mount, M20 (fig. 105).** The M20 has no turret; instead, it is equipped with a ring mount which is secured to the hull by three brackets. The M20 is equipped with a cal. .50 machine gun. The gun is secured to the ring mount on a gun mounting bracket (fig. 105). The gun mounting bracket is supported by rollers on the ring mount and can be traversed completely around the ring mount.

**ORDNANCE MAINTENANCE—POWER TRAIN, SUSPENSION, HULL,  
AND TURRET FOR ARMORED CAR M8 AND UTILITY CAR M20**

**CHAPTER 10**

**HULL AND TURRET (Cont'd)**

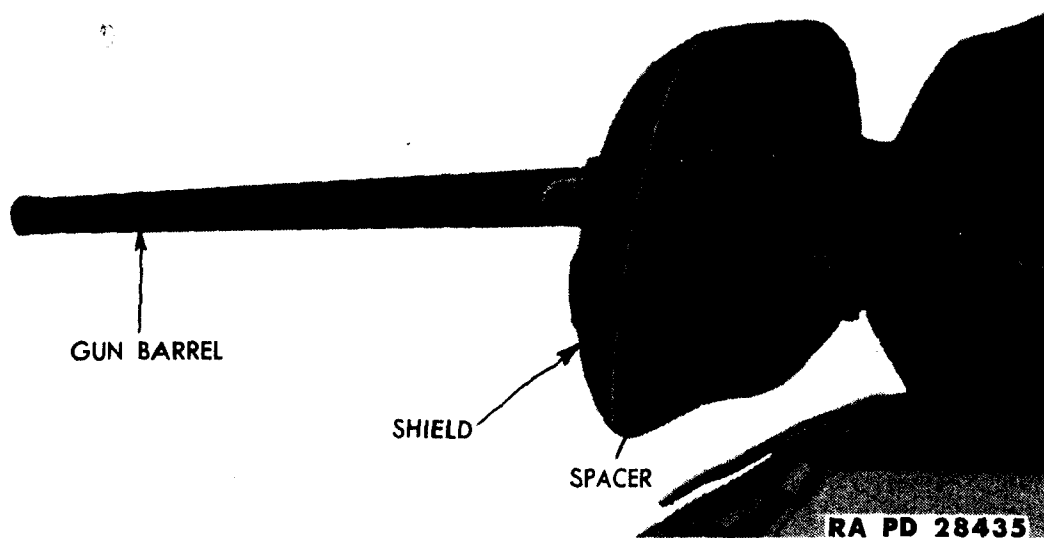
**Section II**

**GUN AND GUN MOUNT FOR LIGHT ARMORED CAR M8**

	<b>Paragraph</b>
Removal of gun and gun mount.....	111
Installation of gun and gun mount.....	112

**111. REMOVAL OF GUN AND GUN MOUNT.**

a. **Remove Shield** (fig. 108). Working from the inside of the turret, remove the two cap screws and the two nuts that secure the shield to the gun mount and slide the shield off the end of the barrel.



**Figure 108—Gun Shield Removal**

b. **Remove Gun** (figs. 109 and 110). Disconnect the two firing cables leading to the machine gun and the 37-mm gun. Remove the two hold-down screws from the dowel pins. Remove the cap screw from the upper dowel pin and remove the flat washers. Install the same cap screw back in the dowel pin and using the cap screw as a puller, remove the dowel pin. Remove the cap screw from the dowel pin that has been removed, install the cap screw in the lower dowel pin, and remove the lower dowel pin. Slowly slide the gun off the mounting until the gun is back far enough so that a lifting cable

### **GUN AND GUN MOUNT FOR LIGHT ARMORED CAR M8**

can be installed on the traveling lock bracket. Figure 109 shows a suitable method of attaching a lifting cable. Tilt the gun to one side as it is withdrawn in order to clear the upper edge of the turret. Remove the gun.



**Figure 109—Tilting 37-mm Gun to Clear Turret**

#### **112. INSTALLATION OF GUN AND GUN MOUNT.**

a. **Install Gun.** Install the lifting cable on the gun (fig. 110). Raise the gun, and insert the gun barrel through the opening on the top of the turret, and start the gun barrel through the opening. It will be necessary to tilt the gun in order to get the gun past the upper edge of the turret (fig. 109). Slide the gun in as far as possible and remove the lifting cable. Line up the gun mount with the dowel pin holes, and install the dowel pins (fig. 111). Install the hold-down screws in the dowel pins. Install the firing cables on the gun.



**ORDNANCE MAINTENANCE—POWER TRAIN, SUSPENSION, HULL,  
AND TURRET FOR ARMORED CAR M8 AND UTILITY CAR M20**

b. **Install Shield.** Raise the shield, and slide it on to the gun barrel. Insert the shield spacers (fig. 108) on the shield studs. Line up the slots on the shield with the keyway on the gun mount. Insert the shield in position, and install the two cap screws that secure the shield to the gun mount.



**Figure 110—Guiding 37-mm Gun Through Opening in Turret**

**GUN AND GUN MOUNT FOR LIGHT ARMORED CAR M8**



**Figure III—37-mm Gun Mounting**

ORDNANCE MAINTENANCE—POWER TRAIN, SUSPENSION, HULL,  
AND TURRET FOR ARMORED CAR M8 AND UTILITY CAR M20

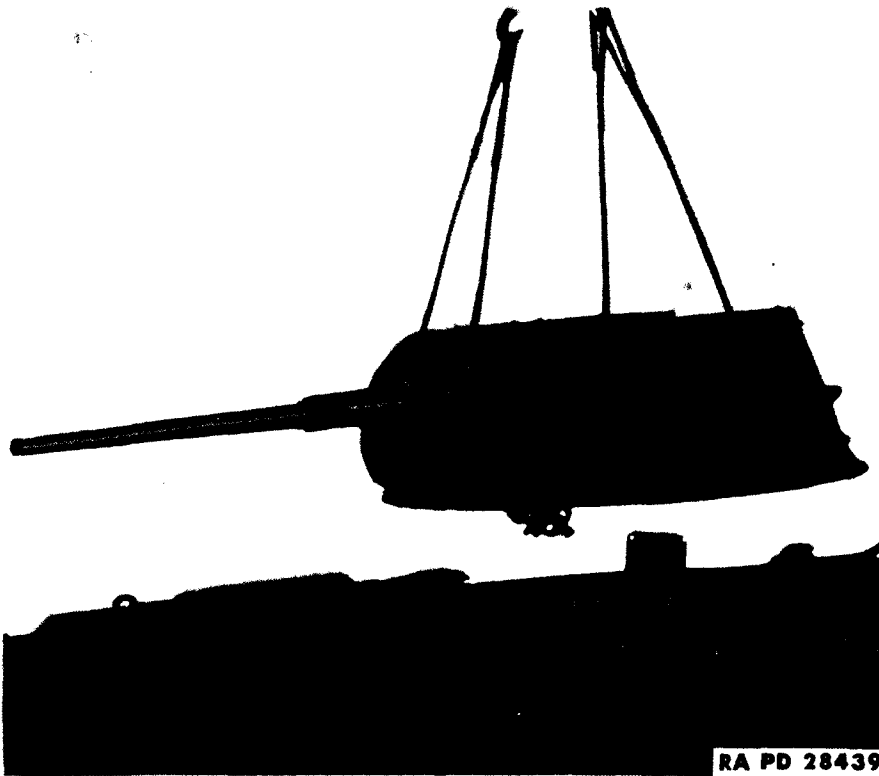
CHAPTER 10

HULL AND TURRET (Cont'd)

Section III

TURRET FOR LIGHT ARMORED CAR M8

	Paragraph
Removal of turret .....	113
Installation of turret .....	114
Support rollers .....	115
Hold-down rollers .....	116
Traversing mechanism (single speed) .....	117
Traversing mechanism (two speed) .....	118
Pintle hook .....	119



RA PD 28439

**Figure 112—Removing or Installing Turret**

**113. REMOVAL OF TURRET** (figs. 109 and 110).

a. Remove the gun and gun mount (par. 111). Remove the bolts that secure the index plates to the hold-down rollers, and remove the index plates. Remove the four bolts from each of the eight hold-

TURRET FOR LIGHT ARMORED CAR M8



Figure 113—Turret Interior

ORDNANCE MAINTENANCE—POWER TRAIN, SUSPENSION, HULL,  
AND TURRET FOR ARMORED CAR M8 AND UTILITY CAR M20

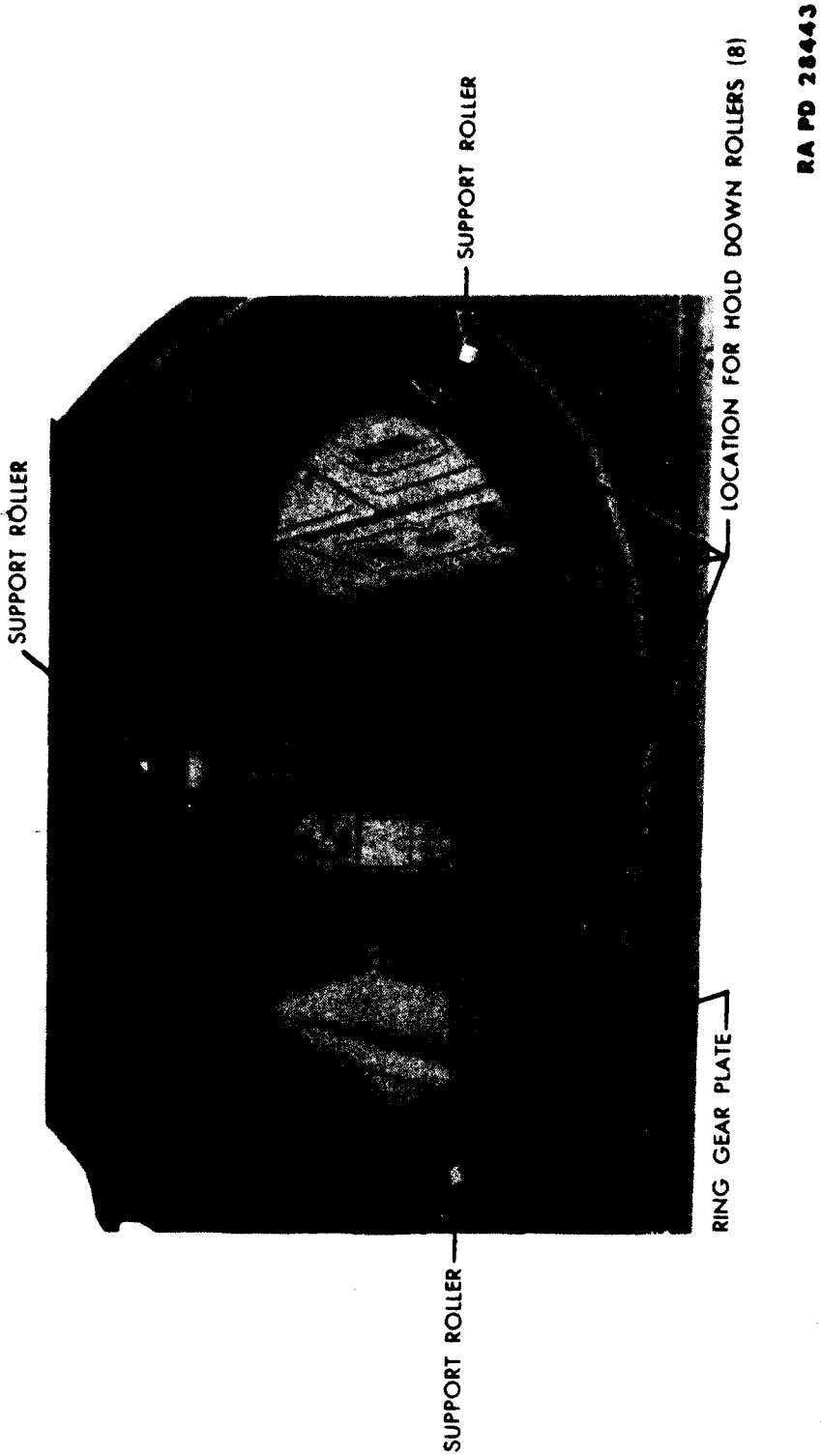
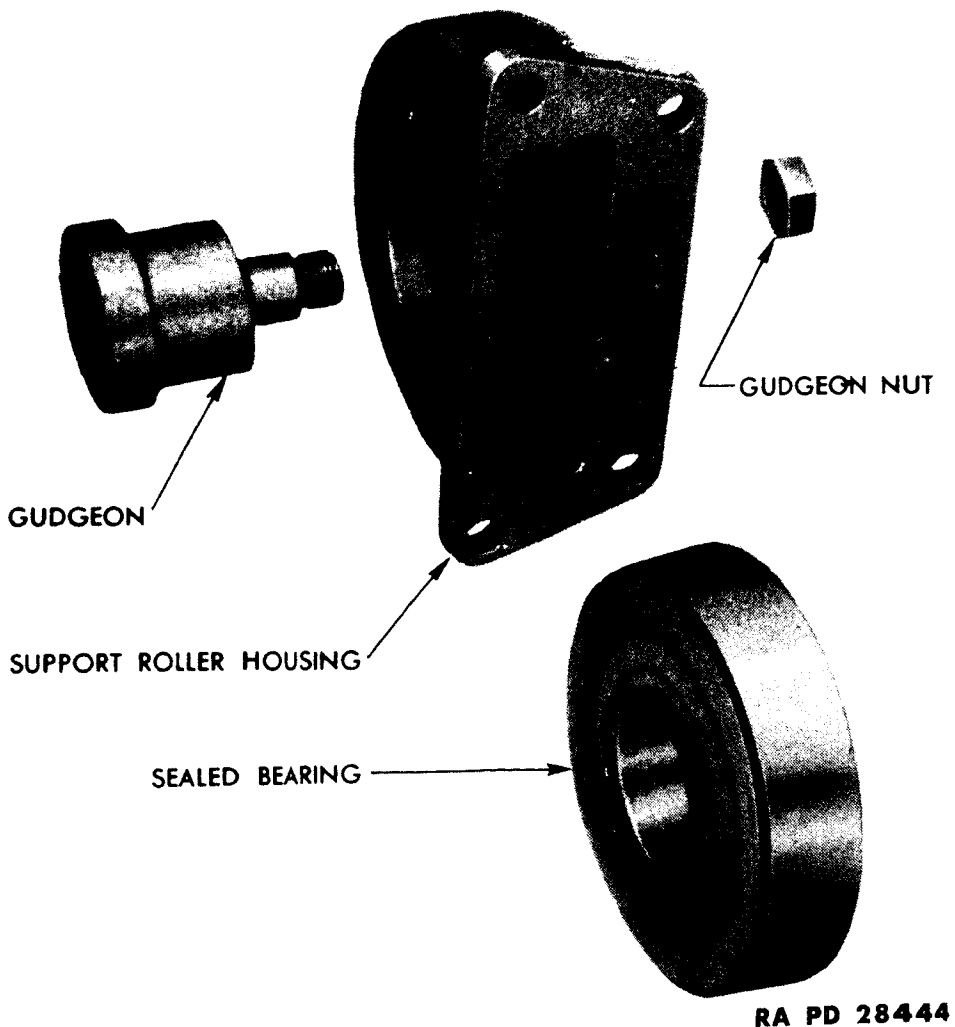


Figure 114—Support Roller in Vehicle

### TURRET FOR LIGHT ARMORED CAR M8

down rollers, and remove the hold-down rollers. Remove the four bolts that secure the traversing mechanism to the turret, and remove the traversing mechanism. Remove the bolts that secure the seat support brackets to the turret. Install the lifting cable on the turret (fig. 112), and raise the turret off the hull. Place the turret on wooden blocks to prevent damage to the machined surface of the bottom of the turret.



**Figure 115—Support Roller, Disassembled**

#### 114. INSTALLATION OF TURRET (fig. 112).

a. Install the lifting cable on the turret. Raise the turret and place it in position on the hull. Remove the lifting cable. Install the eight hold-down rollers and adjust (par. 116 d). Install the index plates on the hold-down rollers, starting with number one at the arrow mark on the turret (fig. 113). Install the seat support bracket to the turret.

## **TM 9-1743**

**114-116**

### **ORDNANCE MAINTENANCE—POWER TRAIN, SUSPENSION, HULL, AND TURRET FOR ARMORED CAR M8 AND UTILITY CAR M20**

Install the traversing mechanism (par. 117 c (2)). Install the gun and the gun mount (par. 112).

#### **115. SUPPORT ROLLERS (fig. 114).**

**a. Removal.** Remove the bolts that secure the index plates (fig. 113) and remove the index plates. Remove the bolts that secure the hold-down rollers. Remove the traversing mechanism (par. 117 a). Install the lifting cable on the turret (fig. 112) and remove the turret. Remove the four nuts that secure each of the support rollers (fig. 114) to the hull, and remove the support rollers.

**b. Disassemble (fig. 115).** Remove the cotter pin and nut from the gudgeon and with a brass drift, tap the gudgeon out of the bearing. Remove the sealed bearing from the support roller housing.

**c. Clean and Inspect.** Clean all parts with dry-cleaning solvent. Check the support roller housing for cracks in the casting. Check the condition of the bearing surface. Oil the bearing immediately to prevent corrosion of the highly polished surfaces. Wrap the bearing in oiled paper unless it is used at once.

**d. Assemble (fig. 115).** Insert the roller in the opening in the support roller housing with the small diameter of the tapered roller toward the side of the housing with the large diameter gudgeon bore. Insert the gudgeon through the bearing and install the nut and cotter pin.

**e. Install (fig. 114).** Place the support roller in position on the ring gear plate. Install the four nuts that secure the support roller to the ring gear plate.

#### **116. HOLD-DOWN ROLLERS.**

**a. Remove.** Remove the screws that secure the index plates (fig. 113) and remove the index plates. Remove the nuts and bolts that secure the hold-down rollers to the hull. Remove the hold-down rollers.

**b. Disassemble (fig. 116).** Remove the castellated nut and flat washer that secure the eccentric spindle in the hold-down roller housing. Remove the eccentric spindle. Install a 1/2-inch, 20-thread bolt in the threaded hole in the roller pin. Using this bolt as a puller, remove the roller pin. The lateral guide roller can now be removed from the housing.

**c. Clean and Inspect.** Clean all parts in dry-cleaning solvent and replace any parts showing excessive wear.

TURRET FOR LIGHT ARMORED CAR M8

RA PD 28445

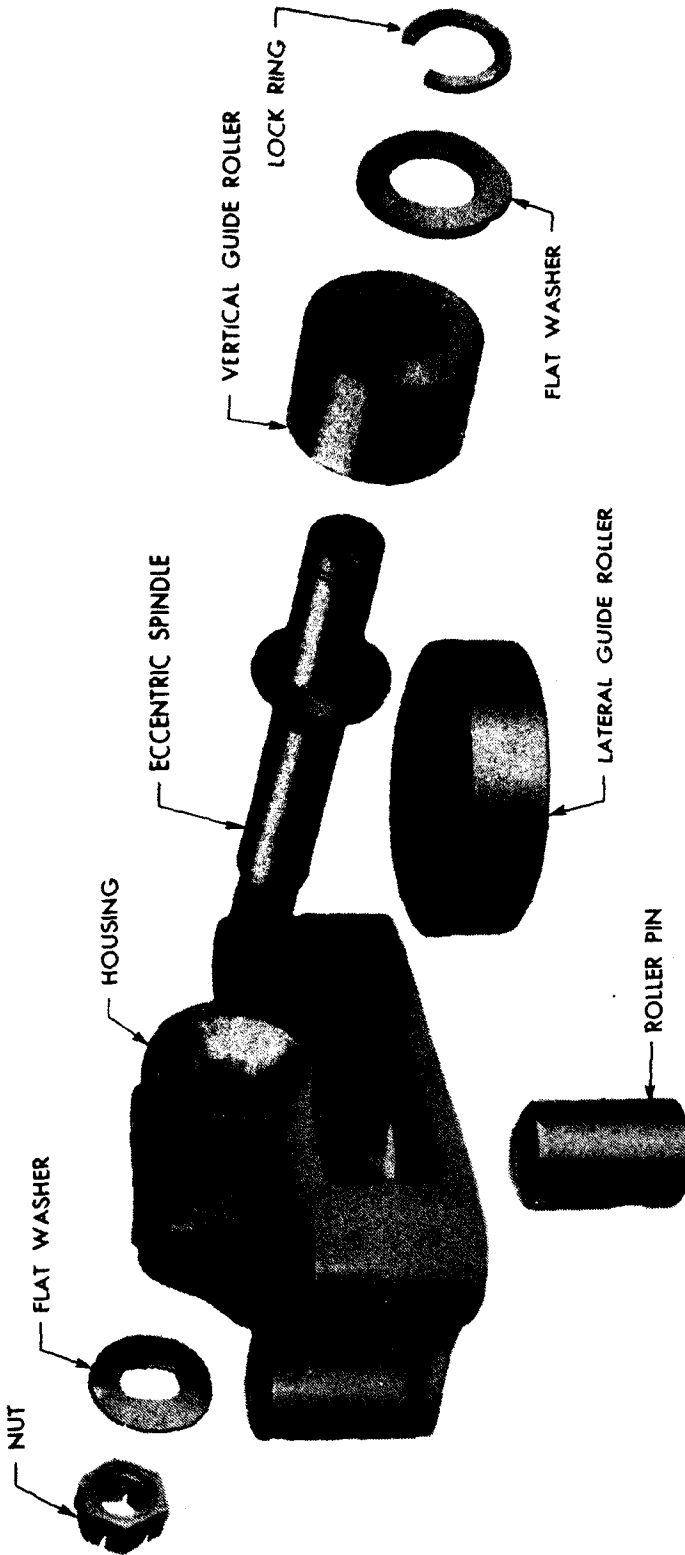
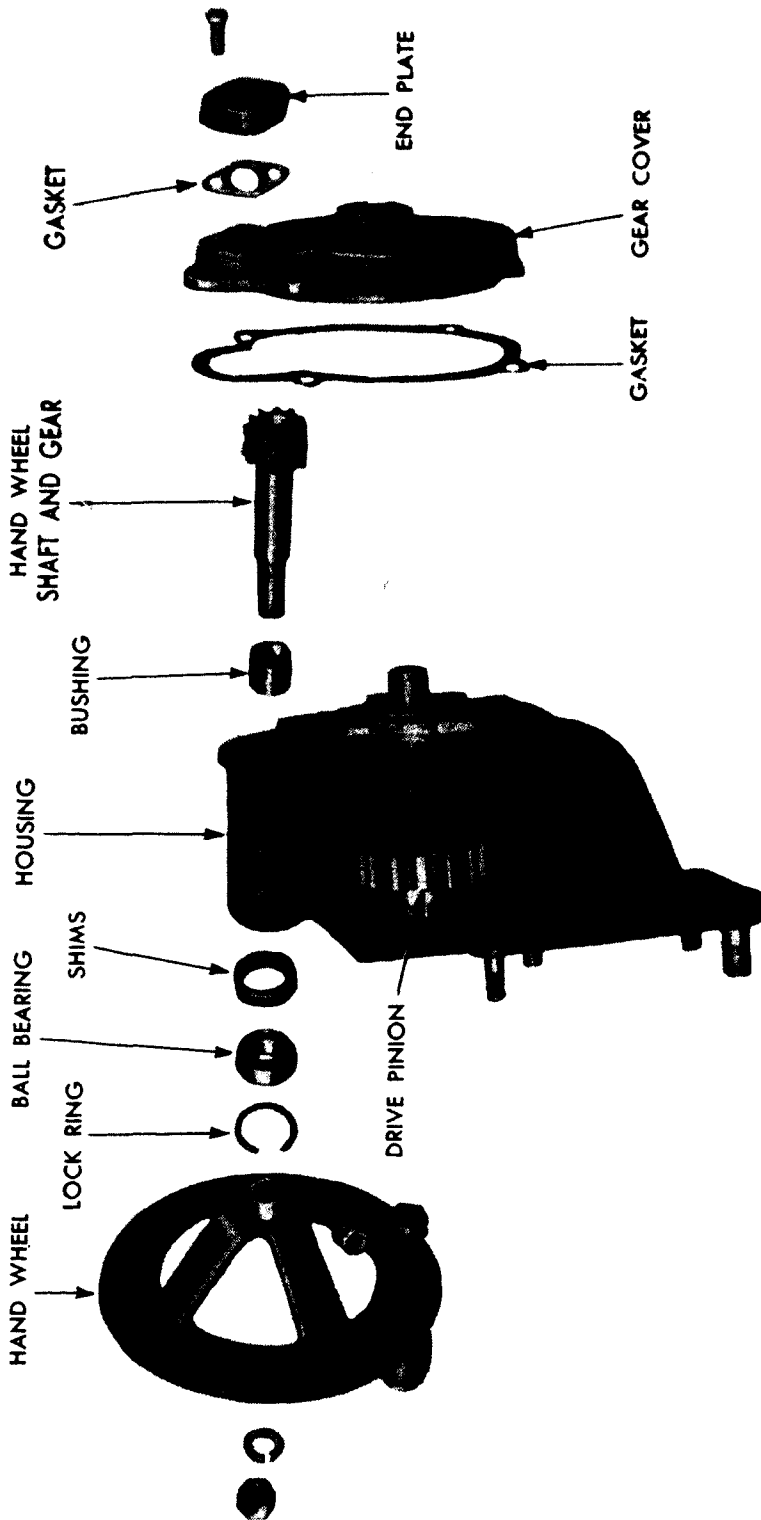


Figure 116—Hold-down Roller, Disassembled



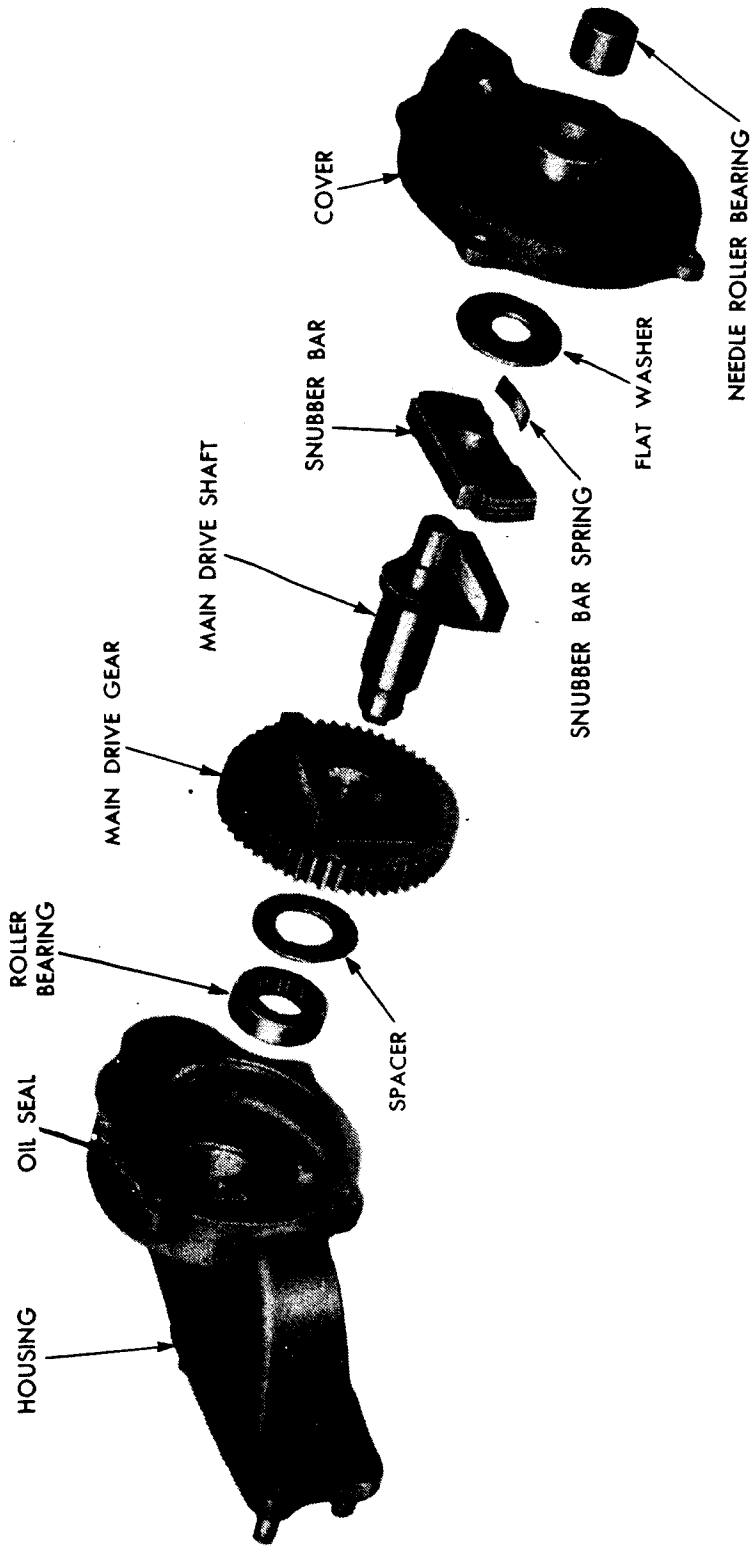
ORDNANCE MAINTENANCE—POWER TRAIN, SUSPENSION, HULL,  
AND TURRET FOR ARMORED CAR M8 AND UTILITY CAR M20



RA PD 28446

Figure 117—Single-speed Traversing Mechanism, Hand Wheel Shaft, Disassembled

TURRET FOR LIGHT ARMORED CAR M8



RA PD 28447

Figure 118—Single-speed Traversing Mechanism, Main Drive Shaft, Disassembled

**ORDNANCE MAINTENANCE—POWER TRAIN, SUSPENSION, HULL,  
AND TURRET FOR ARMORED CAR M8 AND UTILITY CAR M20**

d. **Assemble** (fig. 116). Insert the vertical guide roller on the eccentric spindle and install the flat washer and lock ring. Insert the eccentric spindle in the housing, and install the flat washer and castellated nut that secure the eccentric spindle to the housing. Slide the lateral guide roller in the opening on the housing, and install the roller pin.

e. **Install on Vehicle.** Place the hold-down roller in position on the ring gear plate (fig. 114). Install the four nuts and bolts that secure the hold-down roller to the ring gear plate. Loosen the castellated nut and turn the eccentric spindle with screwdriver clockwise or counterclockwise whichever may be required to obtain 0.005-inch to 0.010-inch clearance between the vertical guide roller and the turret race. After the correct clearance is obtained, tighten the castellated nut and install cotter pin. Stake the flat washer (fig. 116) into the groove in the housing to prevent the shaft from turning. Install the index plates on the hold-down roller, starting with number one at the arrow mark in the turret.

**117. TRAVERSING MECHANISM (SINGLE-SPEED) (fig. 117).**

**a. Disassemble.**

(1) **REMOVE HAND WHEEL AND GEAR COVER** (fig. 117). Remove the nut and flat washer that secure the hand wheel to the traversing mechanism and remove the hand wheel. Remove the four screws that secure the gear cover and remove the gear cover.

(2) **REMOVE HAND WHEEL SHAFT AND BEARING** (fig. 117). Tap the hand wheel shaft out of the traversing mechanism housing. Slide the bearing and shims out of the housing.

(3) **REMOVE MAIN DRIVE GEAR AND DRIVE PINION** (fig. 118). Remove the nut and flat washer that secure the drive pinion and remove the drive pinion. Slide the main gear shaft out of the housing. Remove the spring and snubber from the main drive gear. Insert a brass drift in the opening of the housing, and tap the roller bearing and retainer out of the housing.

**b. Clean, Inspect and Repair.**

(1) **CLEAN AND INSPECT.** Clean all parts with dry-cleaning solvent. Rotate the bearings while immersed in the dry-cleaning solvent until all trace of lubricant has been removed. Oil the bearings immediately to prevent corrosion of the highly polished surfaces. Wrap the bearings in oiled paper, unless they are to be used at once. Check all gears for excessive wear, and chipped or missing teeth. Inspect the

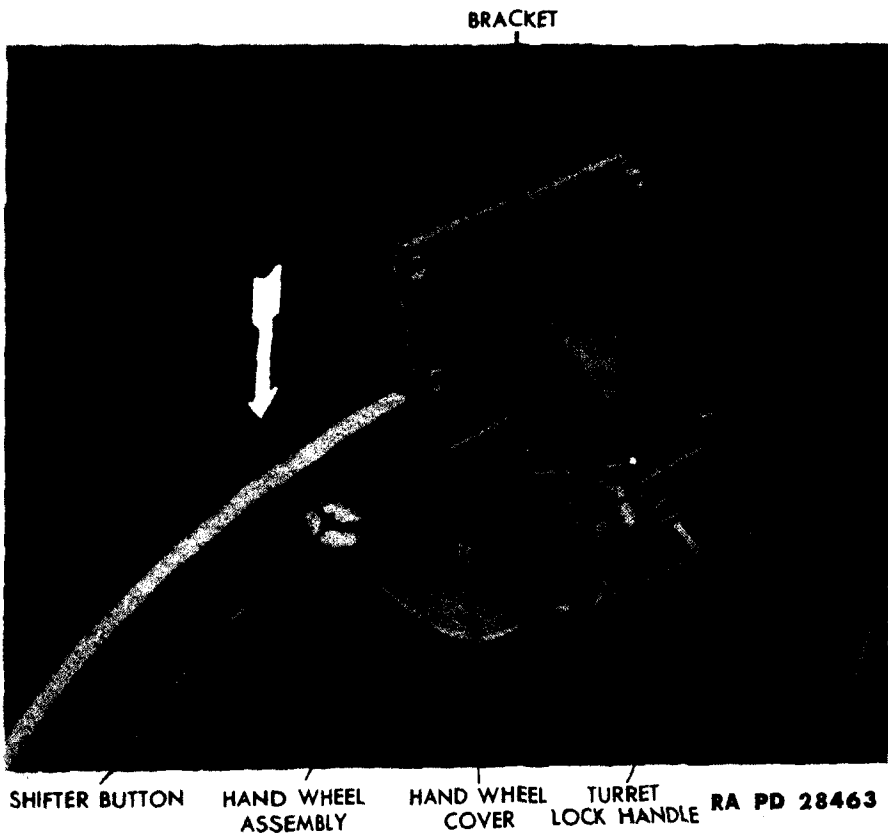
**TURRET FOR LIGHT ARMORED CAR M8**

traversing mechanism housing, gear cover and hand wheel for cracks in the castings. Replace the hand wheel shaft bushing if the inside diameter is worn to more than 0.755 inch. Discard the oil retainer and gaskets.

(2) **HAND WHEEL SHAFT BUSHING REPLACEMENT.** Drive the old bushing out of the housing with a suitable driver. Drive the new bushing into the housing until flush with the shoulder in the housing. Ream the bushing to 0.750 inch.

**c. Assemble.**

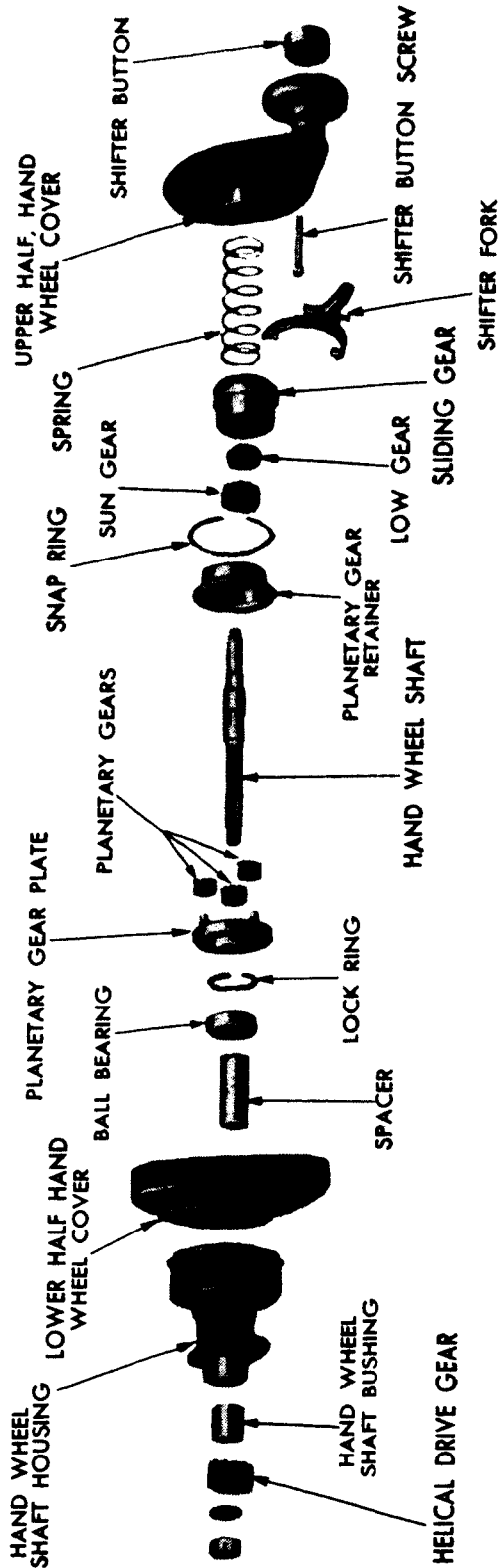
(1) **INSTALL MAIN DRIVE GEAR (fig. 118).** Insert the roller bearing in the housing, and tap the roller bearing in place with a brass



**Figure 119—Two-speed Traversing Mechanism**

hammer. Insert a new oil seal through the outside opening of the housing, tapping the oil seal in place. Insert the main drive gear on the main drive gear shaft. Insert the snubber on the main drive shaft, and slide the spring in the cut-away section of the snubber with the ends of the spring toward the snubber. Place the roller bearing spacer on the roller bearing, and insert the main drive shaft assembly through the roller bearing and oil seal in the housing. Insert the drive pinion (fig. 117) through the opening in the housing and onto the

**ORDNANCE MAINTENANCE—POWER TRAIN, SUSPENSION, HULL,  
 AND TURRET FOR ARMORED CAR M8 AND UTILITY CAR M20**



RA PD 28464

**Figure 120—Two-speed Traversing Mechanism, Hand Wheel Shaft, Disassembled**

TURRET FOR LIGHT ARMORED CAR M8

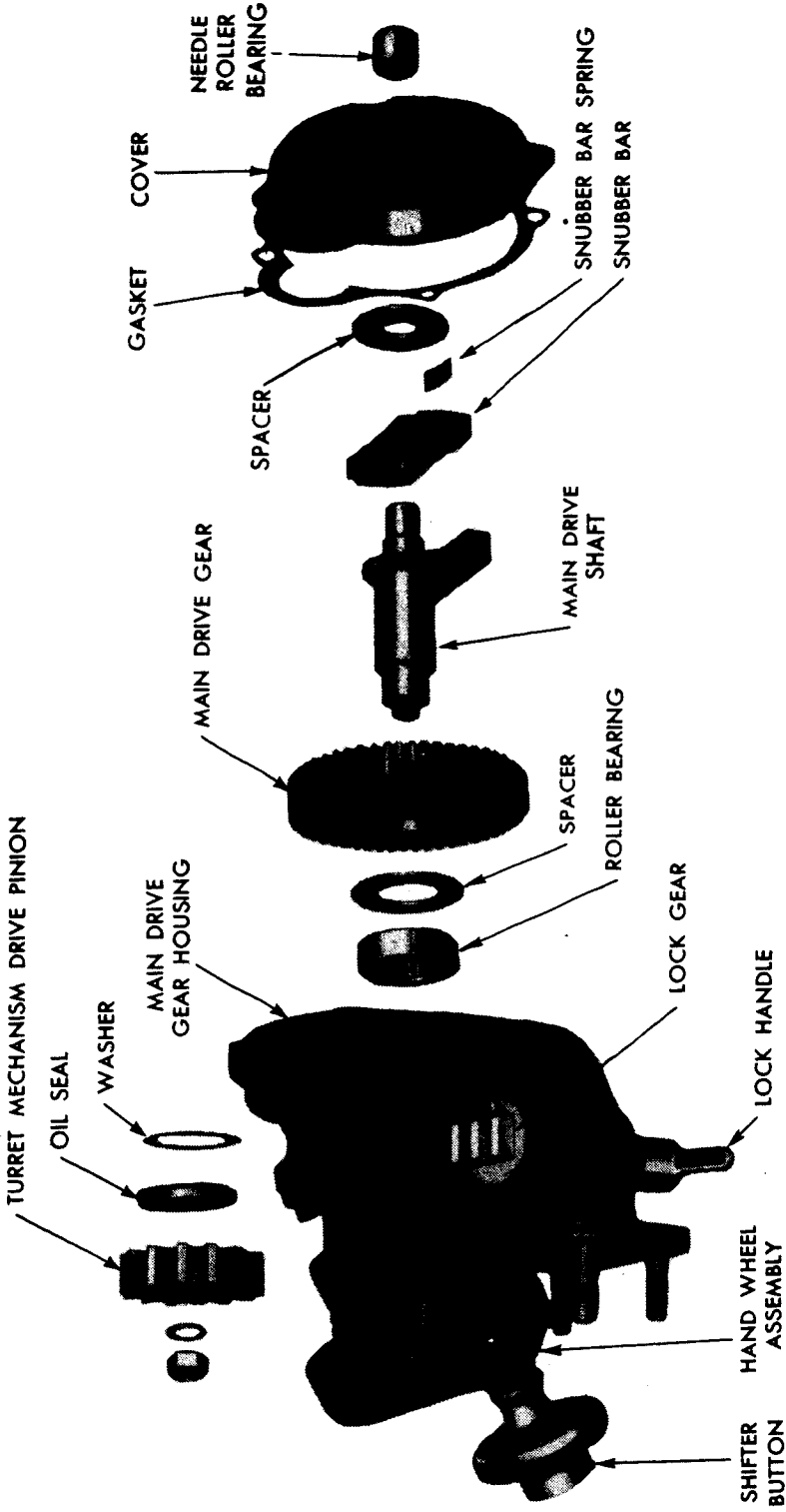


Figure 121—Two-speed Traversing Mechanism, Main Drive Shaft, Disassembled

**ORDNANCE MAINTENANCE—POWER TRAIN, SUSPENSION, HULL,  
AND TURRET FOR ARMORED CAR M8 AND UTILITY CAR M20**

main drive shaft. Install the flat washer and nut on the main drive shaft.

(2) **INSTALL HAND WHEEL SHAFT** (fig. 117). Insert the shims and the ball bearing in place in the housing, using the same amount of shims as were removed in the disassembly of the traversing mechanism. Install the bearing lock ring. If the lock ring cannot be installed, remove just enough shims so that the lock ring can be installed. If the side movement of the bearing is possible, add enough shims to take up this movement. Insert the hand wheel shaft through the bearing. Set the Woodruff key in place and install the hand wheel on the shaft. Fill the traversing mechanism to the recommended level, using the specified oil.

**118. TRAVERSING MECHANISM (TWO-SPEED)** (fig. 119).

**a. Disassemble.**

(1) **REMOVE HAND WHEEL ASSEMBLY** (fig. 119). Remove the nut and flat washer that secure the hand wheel assembly to the hand wheel shaft and remove the hand wheel. Remove the three screws that secure the hand wheel cover and remove the cover. Remove the sliding gear, spring and shifter fork from the hand wheel cover (fig. 120).

(2) **REMOVE HAND WHEEL SHAFT**. Remove the two nuts that secure the hand wheel shaft housing to the main drive gear housing and remove the hand wheel shaft housing. Remove the cotter pin and castellated nut that secure the helical drive gear on the hand wheel shaft and remove the gear. Slide the hand wheel shaft out of the housing. Remove the snap ring that secures planetary gear retainer in the hand wheel shaft housing and remove the retainer. Remove the three planetary gears and the planetary gear plate from the hand wheel shaft housing. Slide the spacer from the housing. Remove the lock ring that secures the ball bearing in the housing and tap the bearing out with a brass drift.

(3) **REMOVE MAIN DRIVE SHAFT** (fig. 121). Remove the four screws that secure the cover to the traversing mechanism housing and remove the cover. Remove the nut and flat washer that secure the turret mechanism drive pinion, and remove the pinion and oil seal from the main drive shaft. Slide the main drive gear and shaft out of the housing. Remove the snubber bar spring and snubber bar from the main drive gear. Insert a brass drift in the opening of the housing, and tap the roller bearing out of the housing.

TURRET FOR LIGHT ARMORED CAR M8

RA PD 28466

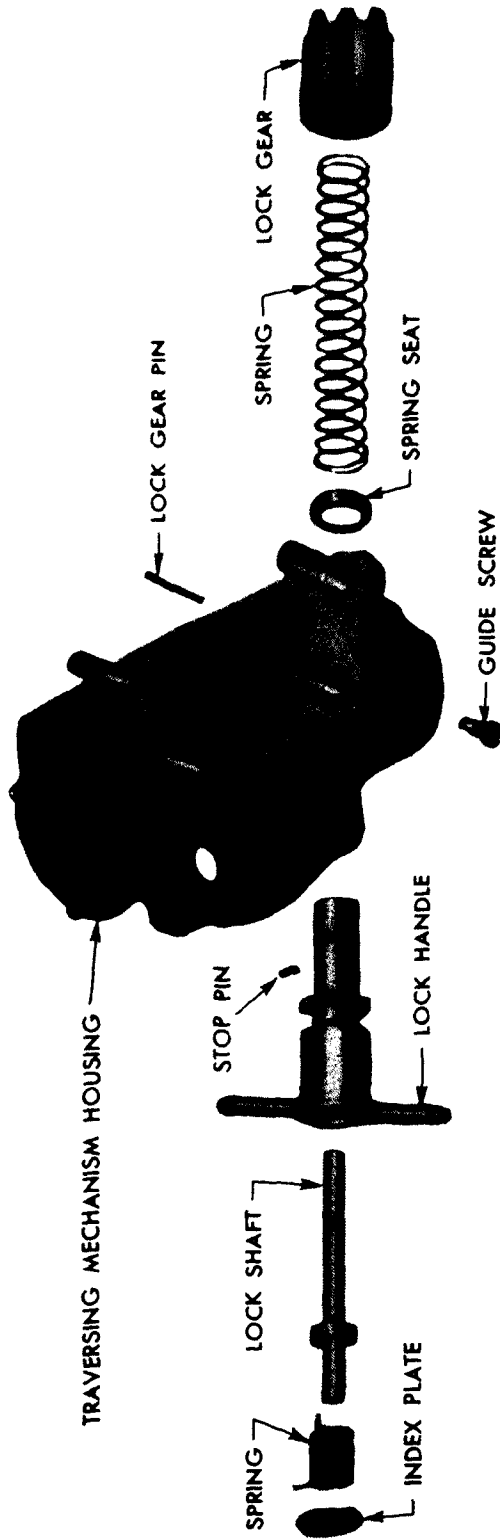


Figure 122 — Turret Lock Mechanism, Disassembled



**ORDNANCE MAINTENANCE—POWER TRAIN, SUSPENSION, HULL,  
AND TURRET FOR ARMORED CAR M8 AND UTILITY CAR M20**

(4) **REMOVE TURRET LOCK** (fig. 122). Through the opening in the traversing mechanism housing, remove the guide screw. Using a long-nosed punch, drive the lock gear pin that secures the lock gear to the turret lock handle (fig. 123), and remove the lock gear and handle from the housing. The spring and spring seat can now be removed



**Figure 123—Removing Pin from Turret Lock Shaft**

from the housing. Remove the two cap screws that secure the index plate on the turret lock handle and remove the index plate. Remove the spring from the handle. With a long-nosed punch, drive the stop pin from the lock shaft and remove the shaft from the handle.

**TURRET FOR LIGHT ARMORED CAR M8**

**b. Clean and Inspect.** Clean all parts with dry-cleaning solvent. Rotate the bearings while immersed in the dry-cleaning solvent until all trace of lubricant has been removed. Oil the bearings immediately to prevent corrosion to the highly polished surfaces. Wrap the bearings in oiled paper unless they are to be used at once. Check all gears for excessive wear, and chipped or missing teeth. Inspect the traversing mechanism gear cover and hand wheel cover for cracks in the casting. Discard the oil seals and gaskets. Replace the hand wheel shaft bushing in the housing if the inside diameter is worn more than 0.882 inch.

**c. Hand Wheel Shaft Bushing Replacement.** Drive the old bushing out of the housing with a suitable driver. Drive a new bushing into the housing until flush with the housing. Ream the bushing to 0.877 inch.

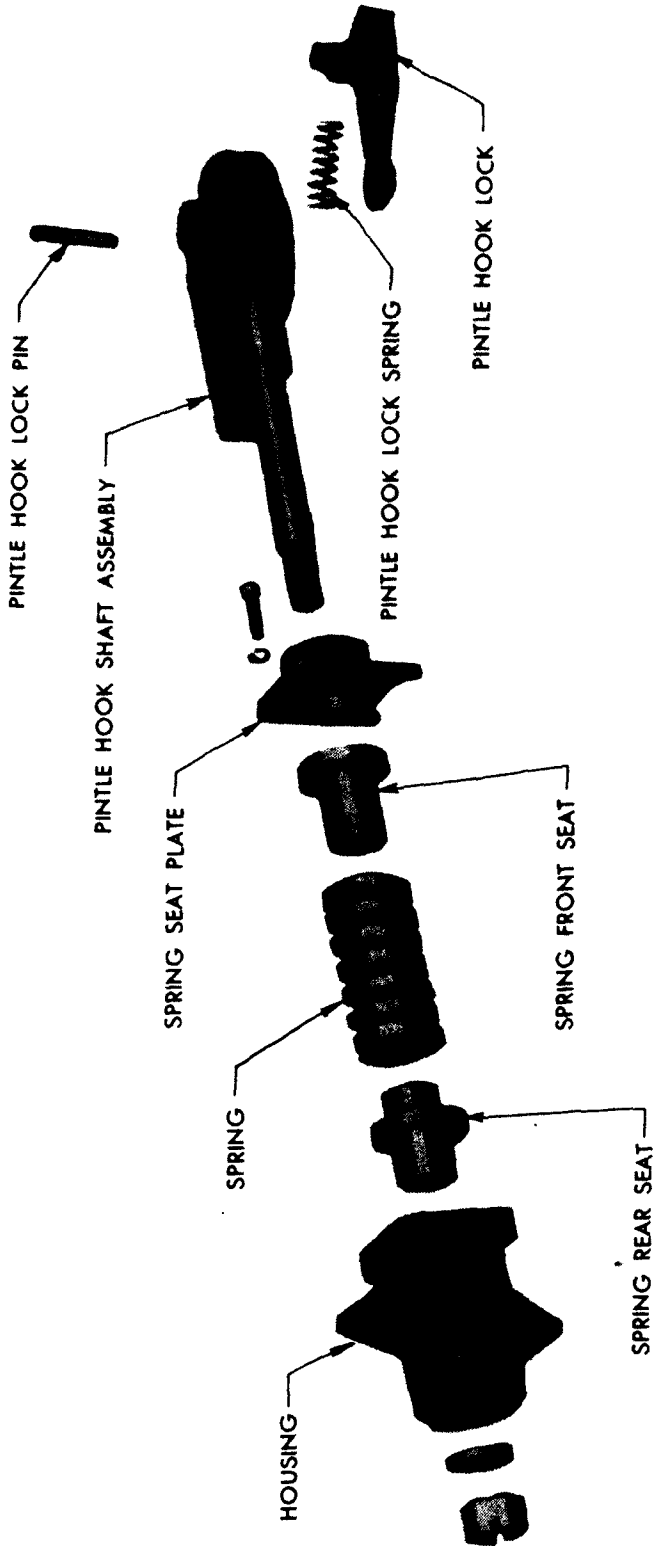
**d. Assemble.**

(1) **INSTALL TURRET LOCK** (fig. 122). Install the lock shaft in the lock handle and install the stop pin in the shaft. Insert the lock handle into the traversing mechanism housing. Slide the spring seat and spring on the shaft. Insert the lock gear on the shaft, making sure the groove in the lock gear is on the side where the guide screw is installed. Line up the hole in the shaft with the hole in the lock gear. Tap the lock gear pin in the lock gear and shaft through the side where the guide screw is installed. Use a long-nosed punch to tap the pin just past the shoulder of the lock gear (fig. 123).

(2) **INSTALL HAND WHEEL SHAFT** (fig. 120). Insert the ball bearing in the housing. Install the lock ring that secures the ball bearing in the housing. Insert the planetary gear plate in the housing, and install the three planetary gears on the gear plate. Insert the retainer in position in the housing, and install the snap ring. Insert the hand wheel shaft in the housing. Insert the spacer in the bushing and onto the hand wheel shaft, and install the helical drive gear. Slide the sun gear on the hand wheel shaft. Insert the Woodruff key in the wheel shaft, and install the low gear, using a brass hammer to tap it in place. Place the lower half of the hand wheel cover in position on the hand wheel shaft housing. Slide the spring and sliding gear on the hand wheel shaft. Insert the shifter fork in position on the sliding gear. Install the three screws that secure the upper half of the hand wheel cover to the lower half. Install the two nuts that secure the hand wheel shaft housing to the traversing mechanism housing.

(3) **INSTALL MAIN DRIVE SHAFT** (fig. 121). Insert and tap the roller bearing in place in the housing with a brass hammer. Insert the washer and a new oil seal through the outside opening of the housing,

ORDNANCE MAINTENANCE—POWER TRAIN, SUSPENSION, HULL,  
AND TURRET FOR ARMORED CAR M8 AND UTILITY CAR M20



RA PD 28448

Figure 124—Pintle Hook, Disassembled

**TURRET FOR LIGHT ARMORED CAR M8**

tapping the oil seal in place. Insert the main drive gear on the main drive gear shaft. Insert the snubber bar on the main drive shaft, and slide the spring in the cut-away section of the bar with the ends of the spring toward the snubber bar. Place the spacer on the roller bearing, and insert the main drive shaft assembly through the roller bearing and oil seal in the housing. Install the traversing mechanism drive pinion onto the main drive shaft through the opening in the housing, and install the flat washer and nut on the main drive shaft.

**119. PINTLE HOOK.**

a. **Remove.** Remove the six bolts that secure the pintle hook to the hull at the rear of the vehicle. Remove the pintle hook.

b. **Disassemble** (fig. 124). Remove the four bolts that secure the housing to the spring seat plate. Remove the cotter pin from the castellated nut and remove the castellated nut and flat washer. Slide the housing off the pintle hook shaft. Slide the rear spring seat, coil spring, front spring seat and spring seat plate off the pintle hook shaft. Remove the cotter pin from the pintle hook lock pin and remove the pin. Remove the pintle hook lock and pintle hook lock spring from the pintle hook.

c. **Clean and Inspect.** Clean all parts with dry-cleaning solvent. Replace all parts that are excessively worn, cracked or otherwise damaged.

d. **Assemble** (fig. 124). Insert the pintle hook lock spring and pintle hook lock in the pintle hook and install the pintle hook lock pin. Insert the spring seat plate on the pintle hook shaft. Insert the front spring seat, coil spring, rear spring seat and housing on the pintle hook shaft. Install the flat washer and castellated nut on the pintle hook shaft and tighten the castellated nut until the housing and spring seat plate are flush. Install the cotter pin in the castellated nut. Install the four bolts that secure the spring seat plate to the housing.

e. **Install Pintle Hook** (fig. 107). Place the pintle hook in position on the rear of the vehicle and install the six bolts that secure it to the hull.

**ORDNANCE MAINTENANCE—POWER TRAIN, SUSPENSION, HULL,  
AND TURRET FOR ARMORED CAR M8 AND UTILITY CAR M20**

**CHAPTER 11**

**FITS AND TOLERANCES, AND TOOLS**

**Section I**

**FITS AND TOLERANCES**

Fits and tolerances.....	Paragraph 120
--------------------------	------------------

**120. FITS AND TOLERANCES.**

**a. Transmission:**

Fit Location Name	Manufacturing Tolerances	Wear Limit	Type of Fit
<b>Main shaft first gear</b>			
bearing seat .....	1.9982 in. to 1.9987 in.	1.997 in.	Running
<b>Main shaft second gear</b>			
bearing seat .....	2.2482 in. to 2.2487 in.	2.247 in.	Running
<b>Main shaft third gear</b>			
bearing seat .....	1.8732 in. to 1.8737 in.	1.872 in.	Running
<b>Main shaft pocket</b>			
bearing seat .....	0.797 in. to 0.7965 in.	0.796 in.	Running
<b>First gear bushing .....</b>	2.0005 in. to 2.000 in.	2.001 in.	Running
<b>Second gear bushing .....</b>	2.2505 in. to 2.250 in.	2.251 in.	Running
<b>Third gear bushing .....</b>	1.8755 in. to 1.875 in.	1.876 in.	Running
<b>Countershaft rear bearing</b>			
seat .....	1.7323 in. to 1.7318 in.	1.731 in.	Running
<b>Reverse idle gear .....</b>	1.797 in. to 1.798 in.	1.799 in.	Running
<b>Idle rollers .....</b>	0.1865 in. to 0.1863 in.	0.186 in.	Running
<b>Needle rollers .....</b>	0.250 in. to 0.2498 in.	0.249 in.	Running

**b. Axles:**

<b>Front axle spindle</b>			
trunnion bushing .....	1.125 in. to 1.126 in.	1.128 in.	Running
<b>Differential ring gear</b>			
thrust plate .....	0.210 in. to 0.215 in.	0.200 in.	Running

**c. Steering:**

<b>Roller shaft bushing .....</b>	1.4995 in. to 1.4975 in.	1.510 in.	Running
-----------------------------------	--------------------------	-----------	---------

**FITS AND TOLERANCES**

**d. Traversing:**

<b>Fit Location Name</b>	<b>Manufacturing Tolerances</b>	<b>Wear Limit</b>	<b>Type of Fit</b>
Main shaft bushing . . . . .	0.752 in. to 0.7525 in.	0.755 in.	Running

**e. Brakes:**

Drums . . . . .	15.000 in. to 15.005 in.	15.060 in.	Running
-----------------	--------------------------	------------	---------

**f. Running Fit.** A running fit is a fit providing enough clearance for a continuous film of oil between the two parts. A running fit usually requires 0.001 inch for the oil film plus a minimum of 0.001 inch clearance for each one inch of diameter.

**ORDNANCE MAINTENANCE—POWER TRAIN, SUSPENSION, HULL,  
AND TURRET FOR ARMORED CAR M8 AND UTILITY CAR M20**

**CHAPTER 11**

**FITS AND TOLERANCES, AND TOOLS (Cont'd)**

**Section II**

**SPECIAL TOOLS**

	<b>Paragraph</b>
Special overhaul tools for the armored car M8 and utility car M20.....	121

**121. SPECIAL OVERHAUL TOOLS FOR THE ARMORED CAR M8 AND UTILITY CAR M20.**

a. Listed below are the special tools used in the overhaul of this materiel. The figure reference is to the illustration which shows the application of the tool.

<b>Nomenclature</b>	<b>Federal Stock Number</b>	<b>Mfr's Number</b>	<b>Figure Number</b>
Plate, assembly, bearing nut, idler shaft . . .	41-P-1522	MAS-6-122	45
Puller, bearing drive and countershaft . . .	41-P-2900-25	MAS-4-110	8
Reamer, carbon steel hand, straight flute, straight shank, 1.4995, 0.0002 in. steering sector shaft bushing . . .	41-R-905-150	WKR-M8-511	95
Reamer, carbon steel hand, straight shank, straight flute transmission oil line . . . . .	41-R-848	MAS-4-152	10
Remover, hub gear seal, inner bearing cone axle . . . . .	41-R-2381-350	WKR-M8-120	59
Remover, pinion bearing race axle . . . . .	41-R-2384-41	WKR-M8-104	76
Remover, universal joint, flange crankshaft, fan pulley and hub drive flange . . . . .	41-R-2384-82	WKR-M8-118	58

**SPECIAL TOOLS**

<b>Nomenclature</b>	<b>Federal Stock Number</b>	<b>Mfr's Number</b>	<b>Figure Number</b>
Remover, water pump bushing, large . . . . .	41-R-2384-177	WKR-M8-211-A	93
Remover and replacer, bearing cone pin, complete with adapt- ers M8, 122A and M8, 122B . . . . .	41-R-2385-135	WKR-M8-122	65, 77, 78
Remover and replacer, bearing cup, transfer case . . . . .	41-R-2385-115	MAS-6-101	42
Remover and replacer, steering housing ca- pacity needle bearing	41-R-2389-33	WKR-M8-508	96
Replacer, axle bearing, cup and grease re- tainer . . . . .	41-R-2390-900	WKR-M8-116	62, 63, 73
Replacer, countershaft bearing . . . . .	41-R-2391-49	MAS-4-150	22
Replacer, hub bearing cup, gear seal re- tainer . . . . .	41-R-2394-108	WKR-M8-107	104
Replacer, hub gear seal, inner bearing cone axle complete with adapters 121A and 121B . . . . .	41-R-2394-130	WKR-M8-121	60, 61 80, 81
Replacer, main drive, gear bearing . . . . .	41-R-2395-9	MAS-6-127	49
Replacer, pitman arm	41-R-2395-110	WKR-M8-503	97, 99
Replacer, oil seal anchor bracket . . . . .	41-R-2390-600	MAS-6-109	38, 39
Replacer, plug shift rail . . . . .	41-R-2395-150	MAS-6-126	13, 41
Replacer, shifter shaft, oil seal . . . . .	41-R-2396-27	MAS-4-129	12, 40



**ORDNANCE MAINTENANCE—POWER TRAIN, SUSPENSION, HULL,  
AND TURRET FOR ARMORED CAR M8 AND UTILITY CAR M20**

<b>Nomenclature</b>	<b>Federal Stock Number</b>	<b>Mfr's Number</b>	<b>Figure Number</b>
Replacer, snap ring main shaft . . . . .	41-R-2396-29	MAS-4-106	15, 19
Replacer, steering sec- tor, shift gear re- tainer bushing . . . . .	41-R-2396-100	WKR-M8-502	94, 98
Replacer, transmission case, main shaft bearing . . . . .	41-R-2397-72	MAS-4-101	20, 21
Replacer, transmission, main shaft bearing, oil seal . . . . .	41-R-2397-95	MAS-4-127	11
Scale, bearing tension	41-S-495	WKR-M8-311	53
Tool, mainshaft third speed gear transmis- sion case assembly locating . . . . .	41-T-3261-450	MAS-4-102	20
Wrench, engineer's single head $\frac{3}{16}$ -in. jaw opening . . . . .	41-W-1470-100	WKR-M8-108	72

**REFERENCES**

**STANDARD NOMENCLATURE LISTS.**

Car, armored, light, M8 (T22E2) (Ford) .....	SNL G-136
Car, armored, utility, M20 .....	SNL G-176
Cleaning, preserving and lubrication materials, recoil fluids, special oils, and miscellaneous ...	SNL K-1
Soldering, brazing, and welding materials, gases, and related items .....	SNL K-2
Tools, maintenance, for repair of automotive vehicles .....	SNL G-27
Tool sets—motor transport .....	SNL N-19
Current Standard Nomenclature Lists are listed above. An up-to-date list of SNL's is maintained in the Index to Ordnance Publications.....	OFSB 1-1

**EXPLANATORY PUBLICATIONS.**

List of publications for training .....	FM 21-6
Military motor vehicles .....	AR 850-15

**Related Technical Manuals.**

Light armored car M8 and armored utility car M20 (Ford) .....	TM 9-743
Ordnance maintenance: Hercules engines.....	TM 9-1832A

**Automotive Materiel.**

Automotive electricity .....	TM 10-580
Electric fundamentals .....	TM 1-455
Sheet metal work, body, fender, and radiator repairs	TM 10-450
The motor vehicle .....	TM 10-510

**Care and Preservation.**

Automotive lubrication .....	TM 10-540
Cleaning, preserving, lubricating, and welding materials, and similar items issued by the Ordnance Department .....	TM 9-850
Detailed lubrication instructions for ordnance materiel .....	OFSB 6-Series
Explosives and demolitions .....	FM 5-25
Motor transport inspections .....	TM 10-545
Ordnance maintenance: Tire repair and retread..	TM 9-1868
Product guide .....	OFSB 6-2

**ORDNANCE MAINTENANCE—POWER TRAIN, SUSPENSION, HULL,  
AND TURRET FOR ARMORED CAR M8 AND UTILITY CAR M20**

**Decontamination.**

Chemical decontamination materials and equipment .....	TM 3-220
Decontamination of Armored Force vehicles.....	FM 17-59
Defense against chemical attack.....	FM 21-40

**Storage and Shipment.**

Registration of motor vehicles .....	AR 850-10
Rules governing the loading of mechanized and motorized army equipment, also, major caliber guns, for the United States Army and Navy, on open top equipment published by Operations and Maintenance Department of Association of American Railroads.	
Storage of motor vehicle equipment .....	AR 850-18
Ordnance field service storage and shipment Chart—group G major items.....	OSSC-G

INDEX

<b>A</b>	Page No.		Page No.
<b>Adjustment</b>			
idle shaft in transfer case . . . . .	80	traversing mechanism (single-speed) . . . . .	163
shock absorbers . . . . .	127	traversing mechanism (two-speed) . . . . .	169
steering gear . . . . .	137		
roller to worm mesh . . . . .	138	<b>B</b>	
worm shaft bearing . . . . .	137	<b>Bogie, springs, shackles, and shock absorbers</b>	
<b>Allocation of maintenance</b> . . . . .	9	bogies	
<b>Arrangement of manual</b> . . . . .	3	assembly . . . . .	123
<b>Assembly</b>		clean, inspect, and repair . . . . .	123
bogies . . . . .	123	description . . . . .	123
brake master cylinder . . . . .	144	disassembly . . . . .	123
brake slave cylinders . . . . .	144	shackles	
control housing . . . . .	43	adjust . . . . .	127
front axle . . . . .	119	description . . . . .	127
differential . . . . .	119	general . . . . .	127
hold-down rollers . . . . .	162	springs	
pillow block . . . . .	55	assembly . . . . .	126
pintle hook . . . . .	171	clean, inspect, and repair . . . . .	126
propeller shafts and universal joints (solid-yoke type) . . . . .	51	description . . . . .	126
propeller shafts and universal joints (U-bolt type) . . . . .	52	<b>Brakes and hubs</b>	
trunnion in yoke . . . . .	52	brake drums . . . . .	139
rear and intermediate axle . . . . .	98	brake master cylinder	
differential . . . . .	98	assembly . . . . .	144
springs . . . . .	126	clean and inspect . . . . .	144
steering gear . . . . .	137	disassembly . . . . .	141
roller shaft . . . . .	138	brake shoes . . . . .	139
steering tube and snubber bar . . . . .	138	brake slave cylinders	
worm and main shaft . . . . .	137	assembly . . . . .	144
support rollers . . . . .	158	clean and inspect . . . . .	144
transfer case . . . . .	83	disassembly . . . . .	144
front axle declutch shaft assembly . . . . .	66	description and data . . . . .	139
idle shaft assembly . . . . .	68	hubs	
input shaft assembly . . . . .	74	bearing cup replacement . . . . .	145
intermediate axle output shaft assembly . . . . .	73	clean and inspect . . . . .	144
main drive gear and shaft . . . . .	75	stud replacement . . . . .	145
rear axle output shaft assembly . . . . .	68		
transmission . . . . .	29	<b>C</b>	
first and second speed synchronizer on main shaft . . . . .	35	<b>Cleaning</b>	
first gear on shaft . . . . .	36	bogies . . . . .	123
idle reverse gear . . . . .	30	brake master cylinder . . . . .	144
main drive gear . . . . .	30	brake slave cylinders . . . . .	144
reverse gear on shaft . . . . .	36	front axle . . . . .	109
second gear on main shaft . . . . .	34	hold-down rollers . . . . .	158
synchronizers . . . . .	31	hubs . . . . .	144
third and fourth speed synchronizer on main drive gear shaft . . . . .	34	pillow block parts . . . . .	53
		pintle hook . . . . .	171
		propeller shafts (both types) . . . . .	51
		rear and intermediate axle . . . . .	93
		shackles . . . . .	127
		springs . . . . .	126

**TM 9-1743**

**ORDNANCE MAINTENANCE—POWER TRAIN, SUSPENSION, HULL, AND TURRET FOR ARMORED CAR M8 AND UTILITY CAR M20**

<b>C—Cont'd</b>	<b>Page No.</b>		<b>Page No.</b>
<b>Cleaning—Cont'd</b>		brake slave cylinders.....	144
steering gear.....	132	control housing.....	21
steering housing and roller		differential.....	108
shaft cover.....	133	front axle.....	106
steering roller shaft.....	132	preliminary work.....	106
steering worm and lower bearing		pillow block.....	53
race, bearing cages, snubber		pintle hook.....	171
bar and jacket bearing.....	135	propeller shafts and universal	
support rollers.....	158	joints (solid-yoke type).....	47
transfer case.....	64	preliminary work.....	47
transmission.....	26	propeller shafts and universal	
traversing mechanism (single-		joints (U-bolt type).....	47
speed).....	162	preliminary work.....	47
traversing mechanism (two-speed)	169	rear or intermediate axle.....	88
universal joints (both types).....	51	differential.....	91
		preliminary work.....	88
		springs.....	126
		steering gear.....	129
		transfer case.....	60
		front axle declutch shaft bear-	
		ing carrier.....	63
		front axle declutch shaft as-	
		sembly.....	66
		idle shaft assembly.....	68
		input shaft assembly.....	74
		intermediate axle output shaft	
		assembly.....	72
		main drive gear and shaft.....	75
		main drive gear bearing cage ...	63
		rear axle output shaft assembly	67
		transmission	
		preliminary work.....	21
		transmission gears.....	25
		idle reverse gear.....	25
		main drive gear.....	25
		main shaft.....	25
		turret	
		hold-down rollers.....	158
		support rollers.....	158
		traversing mechanism (single-	
		speed).....	162
		traversing mechanism (two-	
		speed).....	166
		<b>E</b>	
		Echelon system of maintenance al-	
		location	
		clutch (hydraulic).....	13
		cooling group.....	12

INDEX

E—Cont'd	Page No.		Page No.
Echelon system of maintenance al- location—Cont'd		description . . . . .	103
electrical group . . . . .	13	disassembly	
engine (Hercules JXD) . . . . .	14	axle shaft removal . . . . .	106
exhaust group . . . . .	15	differential disassembly . . . . .	108
fire extinguisher . . . . .	15	differential removal . . . . .	107
front axle . . . . .	10	drive pinion gear shaft removal . . . . .	108
fuel group . . . . .	16	preliminary . . . . .	106
hull . . . . .	16	steering knuckle removal . . . . .	106
instruments and panel . . . . .	17		
miscellaneous . . . . .	17	<b>G</b>	
parking brakes . . . . .	12	Gun and gun mount for armored car M8	
propeller shaft . . . . .	17	gun and gun mount installation . . . . .	151
rear axles and suspension . . . . .	11	gun removal . . . . .	150
service brakes (hydrovac) . . . . .	12	shield removal . . . . .	150
shock absorbers . . . . .	10		
steering group . . . . .	17	<b>H</b>	
tires . . . . .	18	Hull and turret	
transfer case . . . . .	12	difference between M8 and M20	
transmission . . . . .	18	ring mount, M20 . . . . .	149
turret . . . . .	18	turret, M8 . . . . .	148
vehicle assembly		gun and gun mount for M8	
armored car M8 . . . . .	18	installation . . . . .	151
utility car M20 . . . . .	18	removal . . . . .	150
		hull	
<b>F</b>		engine compartment doors . . . . .	148
Fits and tolerances . . . . .	172	fenders and external boxes . . . . .	148
axles . . . . .	172	general description . . . . .	147
brakes . . . . .	173	hatch covers . . . . .	148
running fit . . . . .	173	pintle hook . . . . .	148
steering . . . . .	172	vision devices . . . . .	147
transmission . . . . .	172	turret for M8	
traversing . . . . .	173	installation . . . . .	157
Front axle		hold-down rollers . . . . .	158
assembly		pintle hook . . . . .	171
differential . . . . .	119	removal . . . . .	154
drive pinion gear . . . . .	119	support rollers . . . . .	158
hub and brake drum . . . . .	120	traversing mechanism (single- speed) . . . . .	162
hydraulic lines . . . . .	122	traversing mechanism (two- speed) . . . . .	166
steering knuckle . . . . .	120	Hydraulic lines . . . . .	102, 122
cleaning, inspection, and repair . . . . .	109		
axle housing . . . . .	109	<b>I</b>	
axle shaft drive gears . . . . .	116	Inspection and repair	
axle shafts . . . . .	113	bogies . . . . .	123
pinion gear sleeve . . . . .	112	brake master cylinder . . . . .	144
ring gear and pinion . . . . .	113	brake slave cylinders . . . . .	144
spider and spider gears . . . . .	115	front axle . . . . .	109
spindles . . . . .	116	axle housing . . . . .	109
steering knuckle . . . . .	118		
data . . . . .	103		

**TM 9-1743**

**ORDNANCE MAINTENANCE—POWER TRAIN, SUSPENSION, HULL,  
AND TURRET FOR ARMORED CAR M8 AND UTILITY CAR M20**

<b>I—Cont'd</b>	<b>Page No.</b>		<b>Page No.</b>
<b>Inspection and repair</b>		<b>idle reverse gear</b> .....	27
<b>front axle—Cont'd</b>		<b>main drive gear assembly</b> .....	26
axle shaft drive gears .....	116	<b>main shaft</b> .....	27
axle shafts .....	113	<b>needle bearing rollers</b> .....	27
pinion gear sleeve .....	112	<b>reverse gear</b> .....	27
ring gear and pinion .....	113	<b>synchronizers</b> .....	27
spider and spider gears .....	115	<b>thrust washer</b> .....	28
spindles .....	116	<b>transmission case assembly</b> .....	26
steering knuckle .....	118	<b>traversing mechanism (single-</b>	
<b>hold-down rollers</b> .....	158	<b>speed)</b> .....	162
<b>hubs</b> .....	144	<b>traversing mechanism (two-speed)</b>	169
<b>pillow block parts</b> .....	53	<b>universal joints (both types)</b> .....	51
drive shaft .....	54	<b>Installation</b>	
housing .....	54	<b>control housing</b> .....	43
<b>pintle hook</b> .....	171	<b>universal joint yoke, clutch</b>	
<b>propeller shafts (both types)</b> .....	51	<b>housing and release bearing</b> .....	44
<b>rear and intermediate axle</b>		<b>differential assembly</b> .....	100, 120
axle housing .....	93	<b>drive pinion gear in differential</b>	
axle shaft drive gears .....	97	<b>housing</b> .....	98, 119
axle shafts .....	96	<b>drive pinion gear in sleeve</b> .....	98, 119
pinion gear sleeve .....	95	<b>gears in transmission case</b> .....	37
ring gear and pinion .....	96	<b>bearing and main drive gear</b> .....	37
spider and spider gears .....	97	<b>countershaft gear</b> .....	37
<b>shackles</b> .....	127	<b>front and rear countershaft</b>	
<b>springs</b> .....	126	<b>bearings</b> .....	40
<b>steering gear</b> .....	132	<b>idle gear</b> .....	37
<b>steering housing and roller shaft</b>		<b>main shaft assembly</b> .....	37
<b>cover</b> .....	133	<b>main shaft bearing</b> .....	39
<b>steering roller shaft</b> .....	132	<b>gun and gun mount</b> .....	151
<b>steering worm and lower bearing</b>		<b>shield</b> .....	152
<b>race, bearing cages, snubber</b>		<b>hub and brake drum</b> .....	120
<b>bar and jacket bearing</b> .....	135	<b>hub and brake drum assembly</b> .....	100
<b>support rollers</b> .....	158	<b>hydraulic lines</b> .....	102, 122
<b>transfer case</b>		<b>oil seals and shifter shaft plug</b> .....	29
<b>case, cover and bearing cages</b> .....	65	<b>pillow block</b>	
<b>front axle declutch shaft as-</b>		<b>drive shaft in housing</b> .....	55
<b>sembly</b> .....	66	<b>grease retainer assemblies</b> .....	55
<b>idle shaft assembly</b> .....	68	<b>universal joint flange yokes</b> .....	56
<b>input shaft assembly</b> .....	73	<b>pintle hook</b> .....	171
<b>intermediate axle output shaft</b>		<b>shift rails</b> .....	40
<b>assembly</b> .....	72	<b>first and second speed shift rail</b> .....	43
<b>main drive gear and shaft</b> .....	74	<b>third and fourth speed shift rail</b> .....	43
<b>rear axle output shaft assembly</b>	67	<b>snap rings and grease fitting</b> .....	52
<b>shift mechanism</b> .....	75	<b>steering knuckle</b> .....	120
<b>transmission</b> .....	26	<b>transfer case</b>	
<b>ball bearings</b> .....	28	<b>front axle declutch bearing cage</b>	
<b>countershaft gear</b> .....	27	<b>assembly on transfer case</b>	
<b>first, second, and third gears</b> .....	27	<b>cover</b> .....	80

INDEX

I—Cont'd

Page No.

Page No.

Installation

transfer case—Cont'd

front axle declutch shaft assembly in bearing cage	76
gear and shaft assemblies in transfer case	83
hand brake anchor bracket and hand brake band	83
main drive gear in cover and bearing carrier	81
rear axle output shaft assembly in case	80
shifter fork	76
shifter fork in transfer case	83
turret	157
hold-down rollers on vehicle	162
support rollers	158
turret traversing mechanism (single-speed)	
hand wheel shaft	166
main drive gear	163
turret traversing mechanism (two-speed)	
hand wheel shaft	169
main drive shaft	169
turret lock	169

M

Manual

arrangement of	3
scope of	3

P

Pillow block

assembly	55
cleaning and inspection of parts	53
data	45
description	53

Pintle hook

assembly (solid-yoke type)	51
assembly (U-bolt type)	52
cleaning and inspection of parts	51
data	45
description	45, 47
disassembly (solid-yoke type)	47
disassembly (U-bolt type)	47

R

Rear and intermediate axles

assembly

differential	98, 100
drive pinion gear	98
hub and brake drum	100
hydraulic lines	102
cleaning, inspection, and repair	92
axle housing	93
axle shaft drive gears	97
axle shafts	96
pinion gear sleeve	95
ring gear and pinion	96
spider and spider gears	97
data	85
description	85
disassembly	
differential disassembly	91
differential removal	89
drive pinion assembly removal	90
drive pinion gear shaft removal	90
preliminary work	88

References

explanatory publications

automotive materiel	177
care and preservation	177
decontamination	178
related technical manuals	177
storage and shipment	178
standard nomenclature lists	177

Removal

axle shaft	106
brake drums	106
brake plates and spindles	106
brake plates	89
control housing	
shifter shaft and lever from housing	23
countershaft gear from housing	24
differential	89, 107
pinion gear and shaft assembly	107
universal joint yoke	107
drive gear	24
drive pinion assembly from axle housing	90
drive pinion gear shaft from sleeve	90, 108
gun and gun mount	150
shield	150
hub and brake drum assemblies	89



**TM 9-1743**

**ORDNANCE MAINTENANCE—POWER TRAIN, SUSPENSION, HULL, AND TURRET FOR ARMORED CAR M8 AND UTILITY CAR M20**

<b>R—Cont'd</b>	<b>Page No.</b>	<b>Page No.</b>
<b>Removal—Cont'd</b>		
hydraulic brake lines . . . . .	88	differential bearing cup . . . . . 95, 109
idle reverse gear . . . . .	25	pinion bearing cup . . . . . 113
main drive gear shaft . . . . .	24	thrust plate . . . . . 95, 112
oil seals and shifter shaft plug . . . . .	25	<b>S</b>
pillow block		Scope of manual . . . . . 3
drive shaft from pillow block		Shackles . . . . . 127
housing . . . . .	53	Shock absorbers . . . . . 127
grease retainer housing assemblies . . . . .	53	Special tools . . . . . 174
universal joint yokes from drive shaft . . . . .	53	Springs . . . . . 126
pintle hook . . . . .	171	Steering gear
shift rails . . . . .	23	assembly and adjustment
guide rail . . . . .	23	roller shaft assembly . . . . . 138
steering gear		roller to worm mesh adjustment 138
roller shaft . . . . .	129	steering tube and snubber bar assembly . . . . . 138
worm and main shaft . . . . .	132	worm and main shaft assembly . 137
steering knuckles . . . . .	106	worm shaft bearing adjustment 137
tie rods . . . . .	106	cleaning, inspection and repair
transfer case		snubber bar, and jacket bearing 135
gear and shaft assemblies from case . . . . .	63	steering housing and roller shaft cover . . . . . 133
hand brake anchor bracket . . . . .	61	steering roller shaft . . . . . 132
hand brake drum and band . . . . .	60	steering worm, and lower bearing race . . . . . 135
shifter fork . . . . .	61	data . . . . . 129
universal joint flanges . . . . .	60	description . . . . . 129
trunnion from welded yoke (U-bolt type) . . . . .	50	disassembly
trunnion from yoke (solid-yoke type) . . . . .	47	roller shaft removal . . . . . 129
trunnion from yoke (U-bolt type) . . . . .	50	worm and main shaft removal . . 132
turret . . . . .	154	<b>T</b>
hold-down rollers . . . . .	158	Transfer case
support rollers . . . . .	158	assembly
turret traversing mechanism (single-speed)		final assembly . . . . . 83
hand wheel and gear cover . . . . .	162	front axle declutch shaft . . . . . 76
hand wheel shaft and bearing . . . . .	162	gear and shaft assemblies . . . . . 83
main drive gear and drive pinion . . . . .	162	idle shaft . . . . . 80
turret traversing mechanism (two-speed)		input shaft . . . . . 83
hand wheel assembly . . . . .	166	intermediate axle output shaft . 80
hand wheel shaft . . . . .	166	rear axle output shaft . . . . . 80
main drive shaft . . . . .	166	cleaning, inspection, and repair . . 64
turret lock . . . . .	168	case, cover, and bearing carriers 65
<b>Replacement</b>		front axle declutch shaft assembly . . . . . 66
axle shaft bushing . . . . .	109	idle shaft assembly . . . . . 68
		input shaft assembly . . . . . 73
		intermediate axle output shaft assembly . . . . . 72
		main drive gear and shaft . . . . . 74

INDEX

T—Cont'd	Page No.		Page No.
<b>Transfer case</b>		<b>Traversing mechanism (turret).....</b>	<b>162</b>
cleaning, inspection, and		<b>Turret for M8</b>	
repair—Cont'd		hold-down rollers	
rear axle output shaft assembly	67	assembly.....	162
shift mechanism.....	75	clean and inspect.....	158
data.....	57	disassembly.....	158
description.....	57	installation.....	162
disassembly.....	60	removal.....	158
<b>Transmission</b>		installation.....	157
assembly.....	29	removal.....	154
control housing.....	43	single-speed traversing mechanism	
idle reverse gear.....	30	assembly.....	163
installation of gears in case.....	37	clean, inspect, and repair.....	162
main drive gear.....	30	disassembly.....	162
oil seals.....	29	support rollers	
shift rail installation.....	40	assembly.....	158
shifter shaft plug.....	29	clean and inspect.....	158
synchronizers.....	31	disassembly.....	158
cleaning.....	26	installation.....	158
description and data.....	19	removal.....	158
disassembly		two-speed traversing mechanism	
control housing.....	21	assembly.....	169
gear disassembly.....	25	clean and inspect.....	169
gear removal.....	24	disassembly.....	166
oil seal removal.....	25	hand wheel shaft bushing re-	
preliminary work.....	21	placement.....	169
shift rail removal.....	23		
shifter shaft plug removal.....	25		
gear ratios.....	19		
inspection and repair.....	26		
		<b>U</b>	
		Universal joints.....	47

[A.G. 300.7 (1 Oct. 43)]

BY ORDER OF THE SECRETARY OF WAR:

G. C. MARSHALL,  
*Chief of Staff.*

OFFICIAL:

J. A. ULIO,  
*Major General,*  
*The Adjutant General.*

DISTRIBUTION: R9 (4); Bn 9 (2); C9 (8)  
(For explanation of symbols, see FM 21-6)