

WL 35.
9-13202

TM 9-1320

WAR DEPARTMENT TECHNICAL MANUAL

~~DECLASSIFIED~~

Auth: NND 775128

By NNHP NARS 3-3-78

ORDNANCE MAINTENANCE

75-MM HOWITZERS AND CARRIAGES

This record was previously allocated to RG 319 (Entry No. 382) and is now assigned to RG 287.

UNCLASSIFIED

~~RESTRICTED~~ DISSEMINATION OF RESTRICTED MATTER—
The information contained in restricted documents and the essential characteristics of restricted materiel may be given to any person known to be in the service of the United States, and to persons of undoubted loyalty and discretion who are cooperating in Government work, but will not be communicated to the public or to the press except by authorized military public relations agencies. (See also paragraph 23, AR 380-5, 15 March 1944.)

WAR DEPARTMENT

10 APRIL 1944

REGRADED UNCLASSIFIED BY

AUTHORITY OF DOD DIR. 5200.1 R

BY PKERS ON 140205

WAR DEPARTMENT TECHNICAL MANUAL

TM 9-1320

W1.35:
9-1320

This manual supersedes TM 9-1320, dated 20 June 1941; TB 1320-2, dated 15 October 1943; TB 1300-4 and TB Ord 49, dated 6 May 1943 in so far as these Technical Bulletins pertain to the howitzers mentioned in this manual. Together with War Department Lubrication Orders (Guides) No. 63 and No. 76, this Technical Manual supersedes OFSB 6-C-20, dated 25 March 1943; and OFSB 6-C-26A, dated 15 February 1943.

ORDNANCE MAINTENANCE
75-MM HOWITZERS
AND CARRIAGES



WAR DEPARTMENT

10 APRIL 1944

RESTRICTED DISSEMINATION OF RESTRICTED MATTER—
The information contained in restricted documents and the essential characteristics of restricted materiel may be given to any person known to be in the service of the United States and to persons of undoubted loyalty and discretion who are cooperating in Government work, but will not be communicated to the public or to the press except by authorized military public relations agencies. (See also paragraph 23, AR 380-5, 15 March 1944.)

WAR DEPARTMENT
Washington 25, D. C., 10 April 1944

TM 9-1320, Ordnance Maintenance: 75-mm Howitzers and Carriages, is published for the information and guidance of all concerned.

[A.G. 300.7 (18 February, 1944)]
[O.O. 300.7/1293]

BY ORDER OF THE SECRETARY OF WAR:

G. C. MARSHALL,
Chief of Staff.

OFFICIAL:

J. A. ULIO,
Major General,
The Adjutant General.

DISTRIBUTION: As prescribed in Par 9a, FM 21-6; IBn 9 (3); IC 9 (3).

IBn 9—T/O 9-75, Ord Maint Bn

IC 9—T/O 9-7, Ord MM Co

T/O 9-9, Ord HM Co, FA

T/O 9-57, Ord Depot Co

T/O 9-318, Ord Base Arty & Fire Control
Maint Co

(For explanation of symbols, see FM 21-6.)

CONTENTS

| SECTION | | Paragraphs | Pages |
|-------------|--|------------|---------|
| | I. Introduction | 1- 4 | 1- 16 |
| | II. Tools and equipment for inspection | 5 | 17- 22 |
| | III. Inspection instructions | 6-13 | 22- 43 |
| | IV. Tools and equipment for maintenance and repair | 14-16 | 44- 52 |
| | V. Maintenance and repair instructions | 17-18 | 52- 53 |
| | VI. Maintenance of howitzer..... | 19-22 | 53- 62 |
| | VII. Maintenance of recoil mechanism including bottom sleigh | 23-24 | 62- 71 |
| | VIII. Maintenance of pack howitzer carriages M1 and M8..... | 25-32 | 72-113 |
| | IX. Maintenance of field howitzer carriage M3A3 | 33-42 | 114-172 |
| | X. Lubrication | 43 | 172 |
| | XI. References | 44-46 | 173-175 |
| INDEX | | | 176-179 |

This manual supersedes TM 9-1320, dated 20 June 1941; TB 1320-2, dated 15 October 1943; TB 1300-4 and TB Ord 49, dated 6 May 1943 in so far as these Technical Bulletins pertain to the howitzers mentioned in this manual. Together with War Department Lubrication Orders (Guides) No. 63 and No. 76, this Technical Manual supersedes OFSB 6-C-20, dated 25 March 1943; and OFSB 6-C-26A, dated 15 February 1943.

Section I

INTRODUCTION

1. SCOPE.

a. This manual is published for the information and guidance of Ordnance maintenance personnel. It contains detailed instructions for inspection, disassembly, assembly, maintenance, and repair of the 75-mm howitzer materiel, supplementary to the instructions in the Field Manuals and Technical Manuals prepared for the using arms. This manual does not contain information which is intended primarily for the using arms, since such information is available to Ordnance maintenance personnel in TM 9-320, TM 9-319, FM 6-70, and FM 6-110.

2. CHARACTERISTICS.

a. The 75-mm Pack Howitzer M1 or M1A1 is mounted on either of two types of carriages. These two types are the M1 and M8 modified box trail and the M3A1, M3A2, and M3A3 split trail carriages.

b. The M1 Carriage is arranged for dismounting into mule packs, and the M8 is adapted to paracrate packs for parachute delivery. The M1 Carriage, which is the mule pack carriage, has wooden wheels and steel tires (figs. 1 and 2), while the M8 Carriage is equipped with commercial automotive type wheels and pneumatic tires (figs. 3, 4, and 6).

c. The M3A1, M3A2, and M3A3 are the 75-mm field howitzer carriages and may be distinguished by their split trails, pneumatic tires, and firing bases (figs. 7, 8, 9, and 10).

d. The howitzer tube, breech mechanism, firing lock, top and bottom sleighs, and recoil mechanism are the same on both types of carriages.

3. DIFFERENCES AMONG MODELS.

a. The M1 and M8 Pack Howitzer Carriages are identical except for the wheels and axle arms. The M1 Carriage is equipped with wooden wheels and steel rims and bronze bushings. The M8 Carriage

ORDNANCE MAINTENANCE
75-MM HOWITZERS AND CARRIAGES

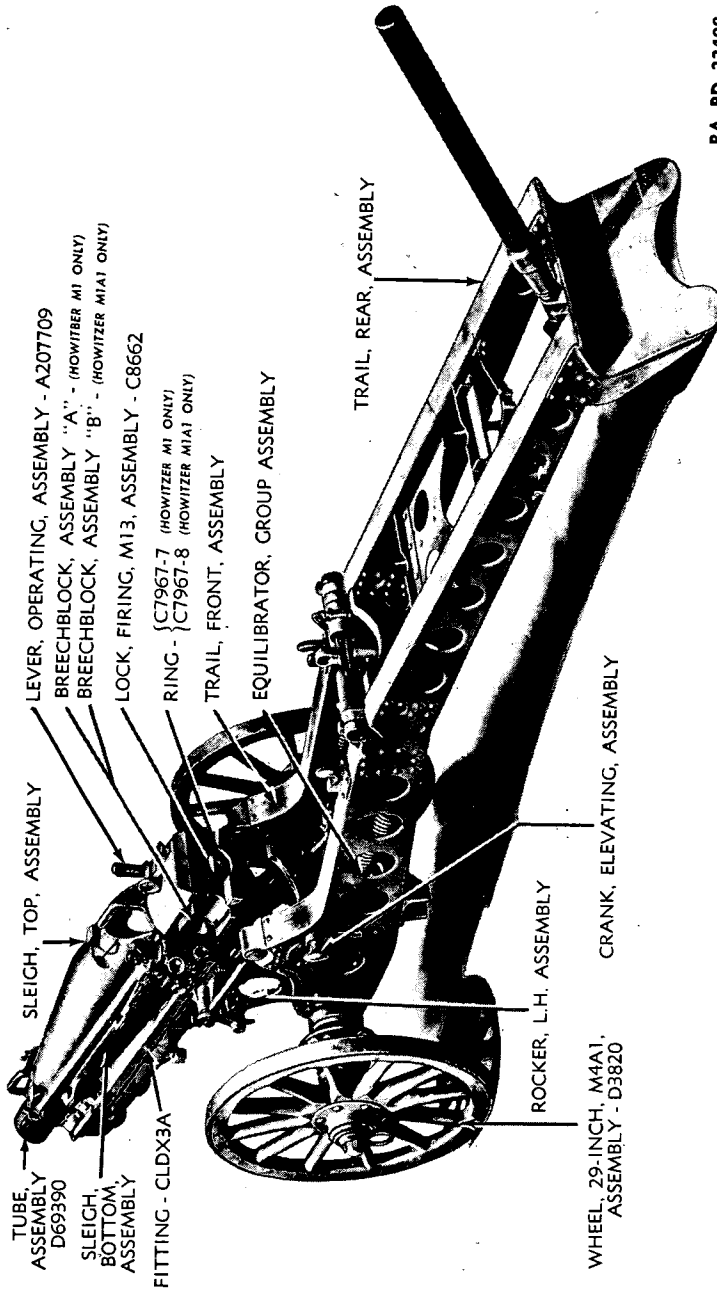

RA PD 22408

Figure 1—75-mm Pack Howitzer M1A1 and Carriage M1 in Firing Position—Left Side

INTRODUCTION

RA PD 76811

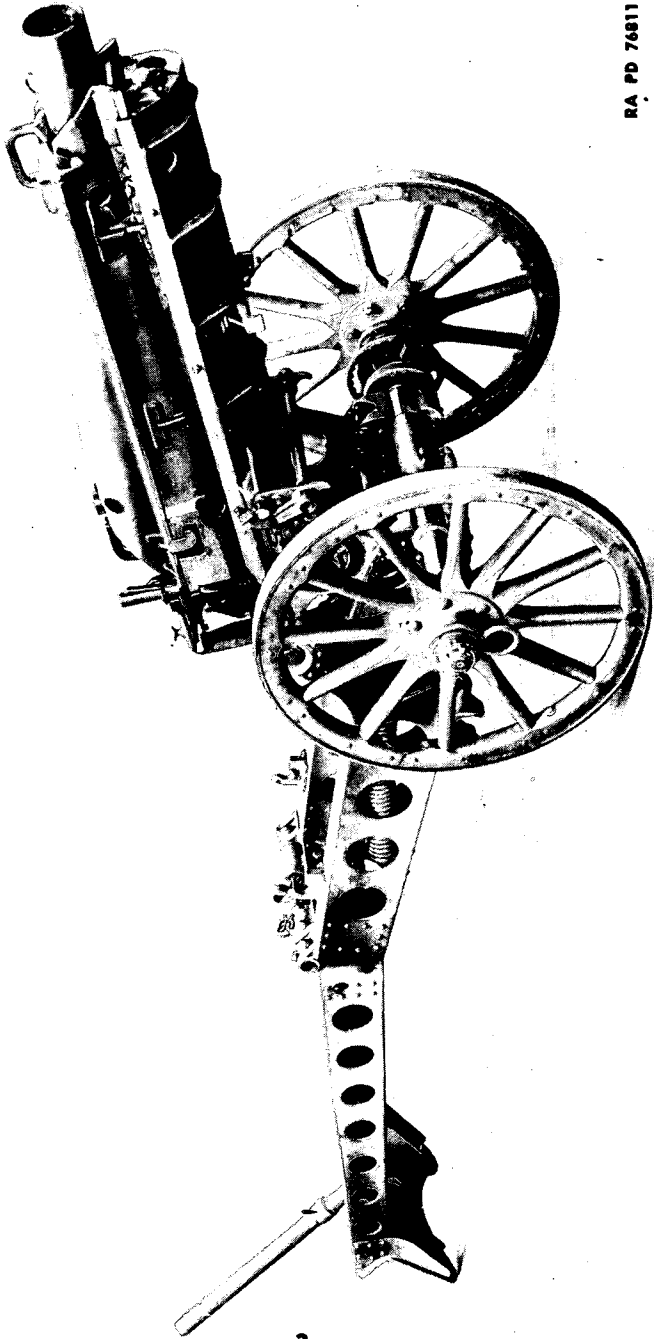

Figure 2—75-mm Pack Howitzer M1A1 and Carriage M1 in Firing Position—Right Side

ORDNANCE MAINTENANCE
75-MM HOWITZERS AND CARRIAGES

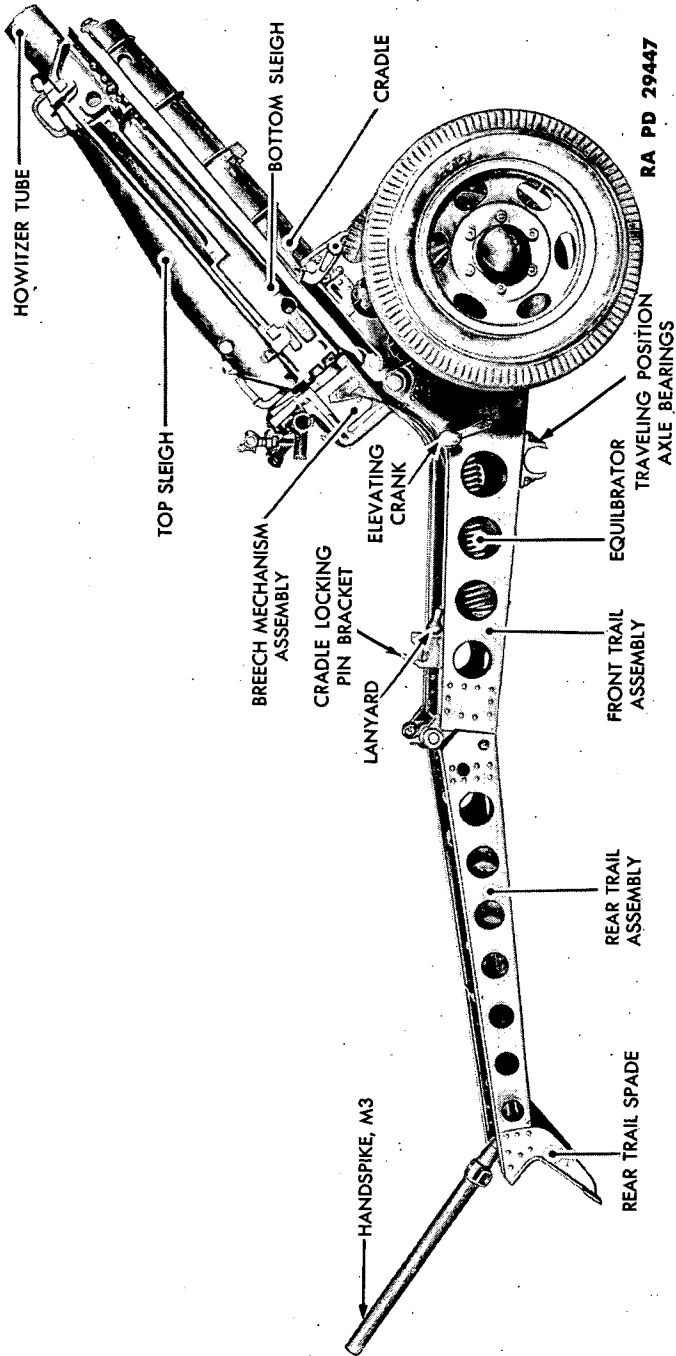

Figure 3—75-mm Pack Howitzer M1A1 and Carriage M8—Howitzer Fully Elevated

INTRODUCTION

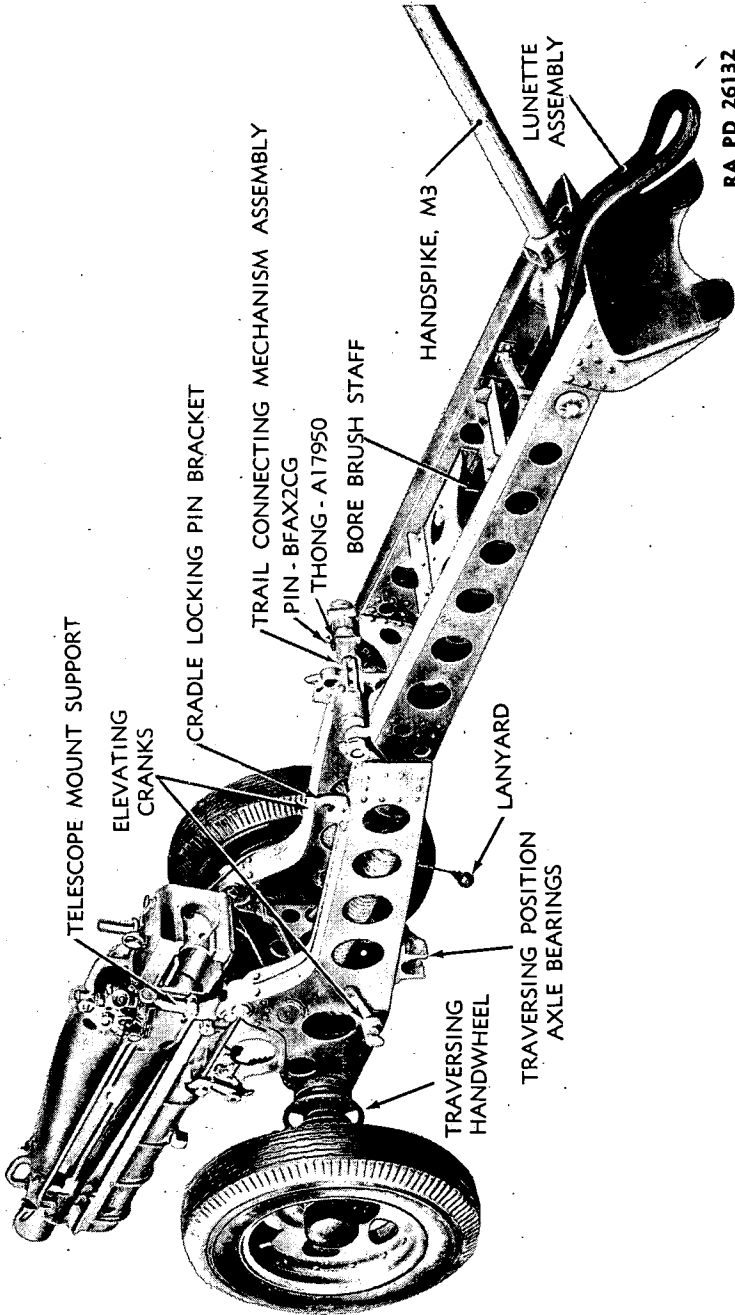
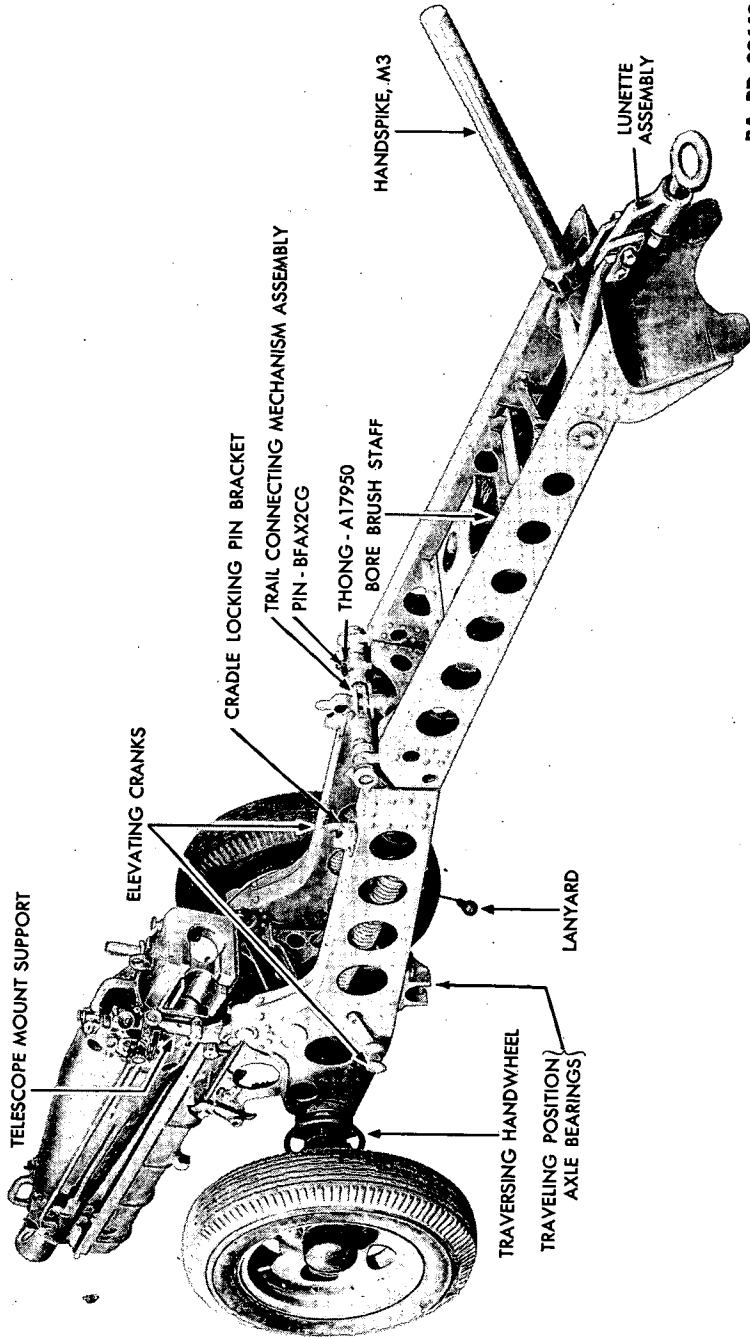

Figure 4—75-mm Pack Howitzer M1A1 and Carriage M8—Left Side

ORDNANCE MAINTENANCE
75-MM HOWITZERS AND CARRIAGES



RA PD 29449

Figure 5—75-mm Pack Howitzer M1A1 and Carriage M8 With Standard Lunette—Left Side

INTRODUCTION

is equipped with rubber-tired wheels and tapered roller bearings. It is also equipped with a lunette for high speed towing.

b. The M3A1, M3A2, and M3A3 Field Howitzer Carriages are basically the same carriage. The M3A2 Carriage is the M3A1 Carriage equipped with shields. The M3A3 is the M3A1 Carriage equipped with shields and combat tires with divided rims.

c. Two types of lunettes may be found in use with this weapon. The earlier type is a nonstandard (fig. 4) and fixed type except for complete removal from the rear trail, paracrate packing, or for firing. The standard type lunette (fig. 5) is designed so that it may be retained in place and simply folded forward for parachute delivery or for firing.

4. DATA.

a. 75-mm Pack Howitzer M1 and M1A1.

| | |
|--|--|
| Weight with breech mechanism..... | 342 lb |
| Length | 15.9 cal. |
| Rifling | Uniform, right; one turn in 20 calibers; 28 grooves, 0.03 in. deep |
| Diameter of bore between lands..... | 2.95 in. |
| Pressure (max)..... | 26,000 psi* |
| Muzzle velocity (SHELL, HE, M48 w/charge 4) (max)..... | 1,250 fps** |
| Muzzle velocity (SHELL, HE, M48 w/charge 1) (min)..... | 700 fps** |
| Estimated accuracy life..... | 12,000 rounds |
| Breech mechanism..... | Horizontal sliding wedge |
| Firing mechanism (Firing Lock M13)..... | Continuous pull |
| Range (max)..... | 9,489 yd |
| Rate of fire: | |
| Short bursts..... | 6 rounds per min |
| Prolonged firing..... | 3 rounds per min |
| Type of ammunition..... | Fuzed, fixed, and semifixed, complete round |
| Method of loading..... | Hand |
| Weight of projectile (approx)..... | 14.6 lb |

*Pounds per square inch.
**Feet per second.

ORDNANCE MAINTENANCE
75-MM HOWITZERS AND CARRIAGES

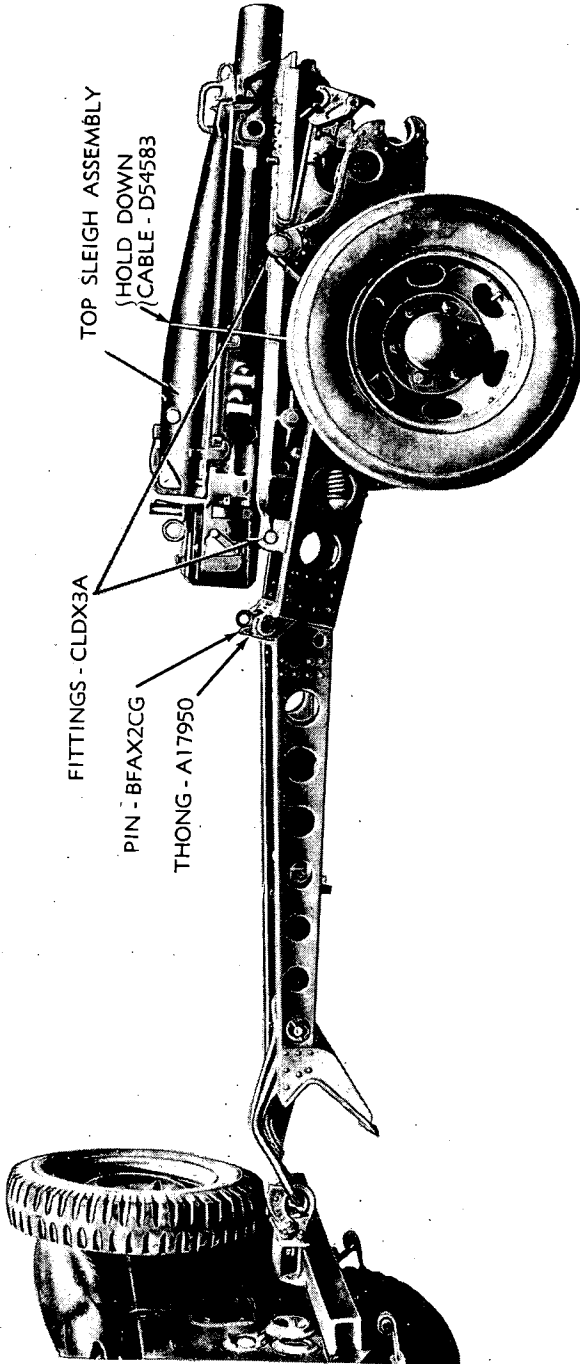

RA PD 29451

Figure 6—75-mm Pack Howitzer M1A1 and Carriage M8 in Traveling Position

INTRODUCTION

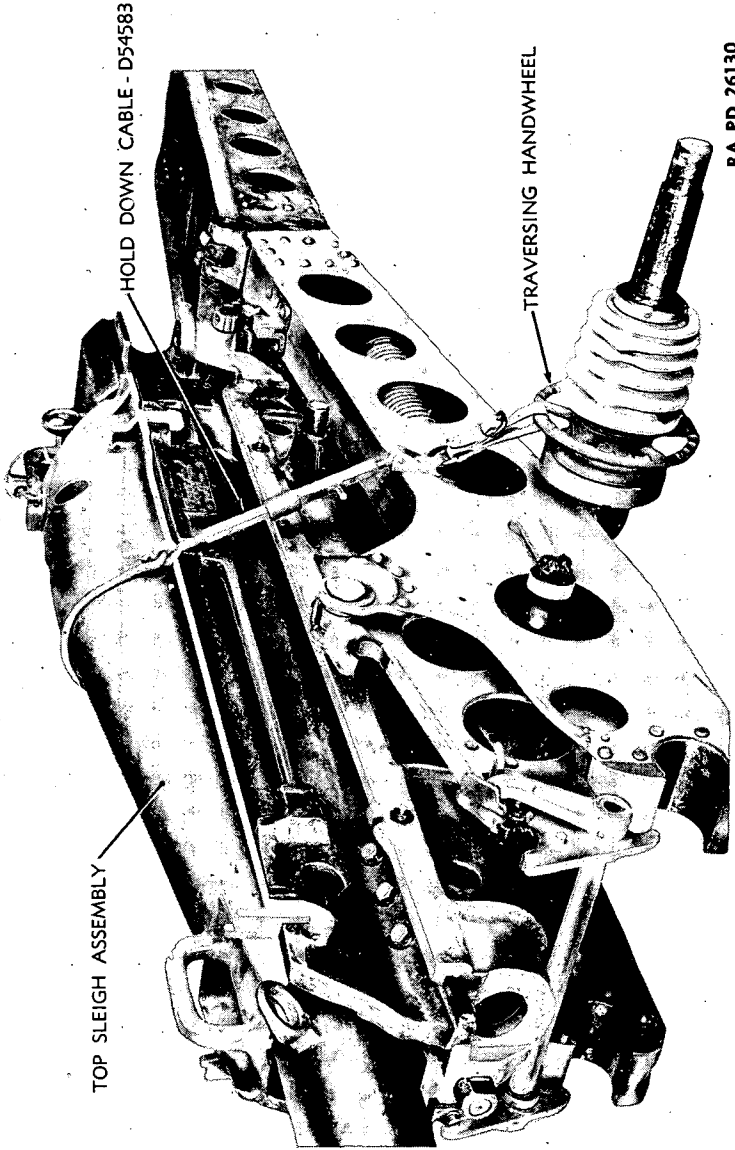

RA PD 26130

Figure 6a—75-mm Howitzer Carriage M8—Hold Down Cable

ORDNANCE MAINTENANCE
75-MM HOWITZERS AND CARRIAGES

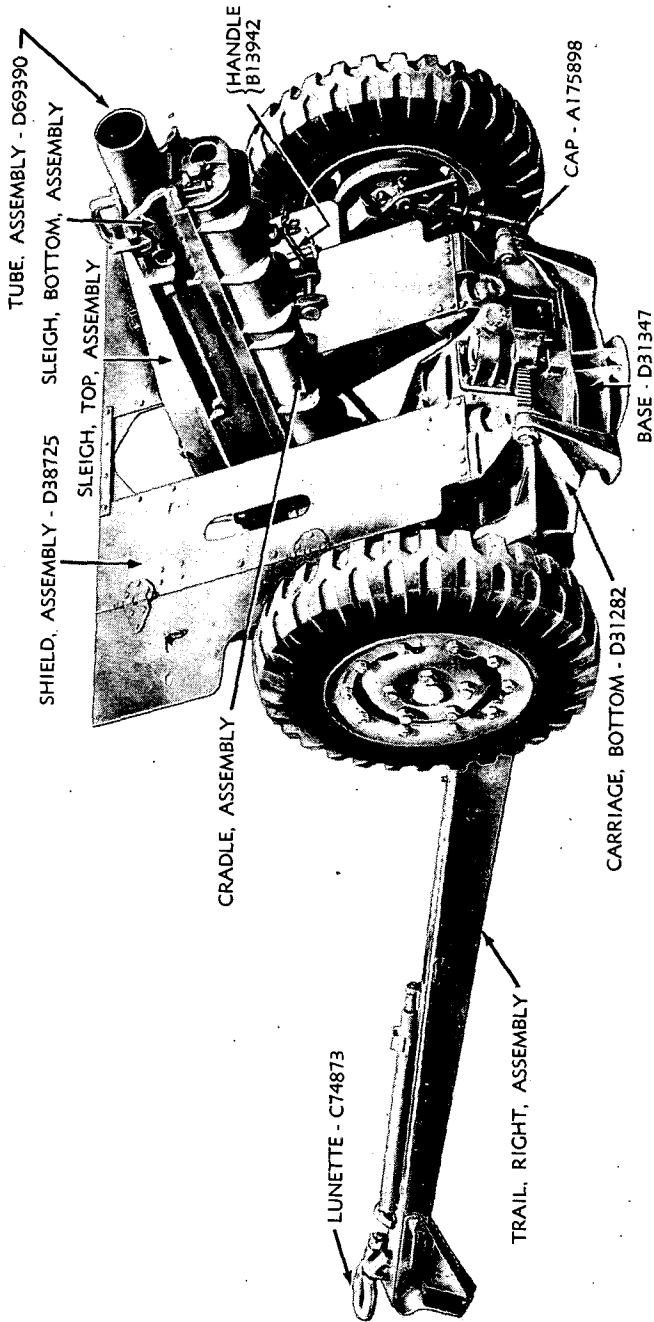

RA PD 26121

Figure 7—75-mm Pack Howitzer M1A1 and Carriage M3A3 in Firing Position

INTRODUCTION

b. 75-mm Howitzer Carriages.

| | CARRIAGES | | |
|---|---|---|--|
| | M1 (Pack) | M8 (Airborne) | M3A3 (Field) |
| Weights: | | | |
| Howitzer and carriage in firing position | 1,269 lb | 1,440 lb | 2,225 lb |
| Howitzer and carriage in traveling position | 1,470 lb | 1,440 lb | 2,300 lb |
| Type | Modified box trail | Modified box trail | Split trail |
| Dimensions, over-all, traveling position: | | | |
| Length | — | 145 in. | 155 in. |
| Width | — | 48 in. | 68 in. |
| Height (zero elevation) | — | 37 in. | 44 in. |
| Recoil mechanism: | | | |
| Type, M1A4 | Hydropneumatic, constant with floating piston | Hydropneumatic, constant with floating piston | Hydropneumatic, constant with floating piston |
| Transportation | 6-mule pack | 1/4 ton, 4 x 4 truck Airplane glider | 1/4 ton, 4 x 4 truck Limber and caisson 6-horse team |
| Time to emplace | 3 min | — | 3 min |
| Brakes | None | None | Mechanical, hand |
| Lunette reaction | — | 40 lb | 47 lb |
| Tires: | | | |
| Size | Wooden wheels w/steel rims | 6.00 x 16 | 8.00 x 16 |
| Recommended pressure | — | 20 psi* | 30 psi* |
| Sighting equipment: | | | |
| Telescope, panoramic | — | — | M1 |
| Elbow telescope | M62 | M62 | — |
| Telescope adapter | — | M9 | M9 |
| Mount, telescope, model | M3 | M3 | M16 |
| Telescope, elbow model | — | — | M5 |
| Quadrant, range, model | — | — | M3 |

*Pounds per square inch.

ORDNANCE MAINTENANCE
75-MM HOWITZERS AND CARRIAGES

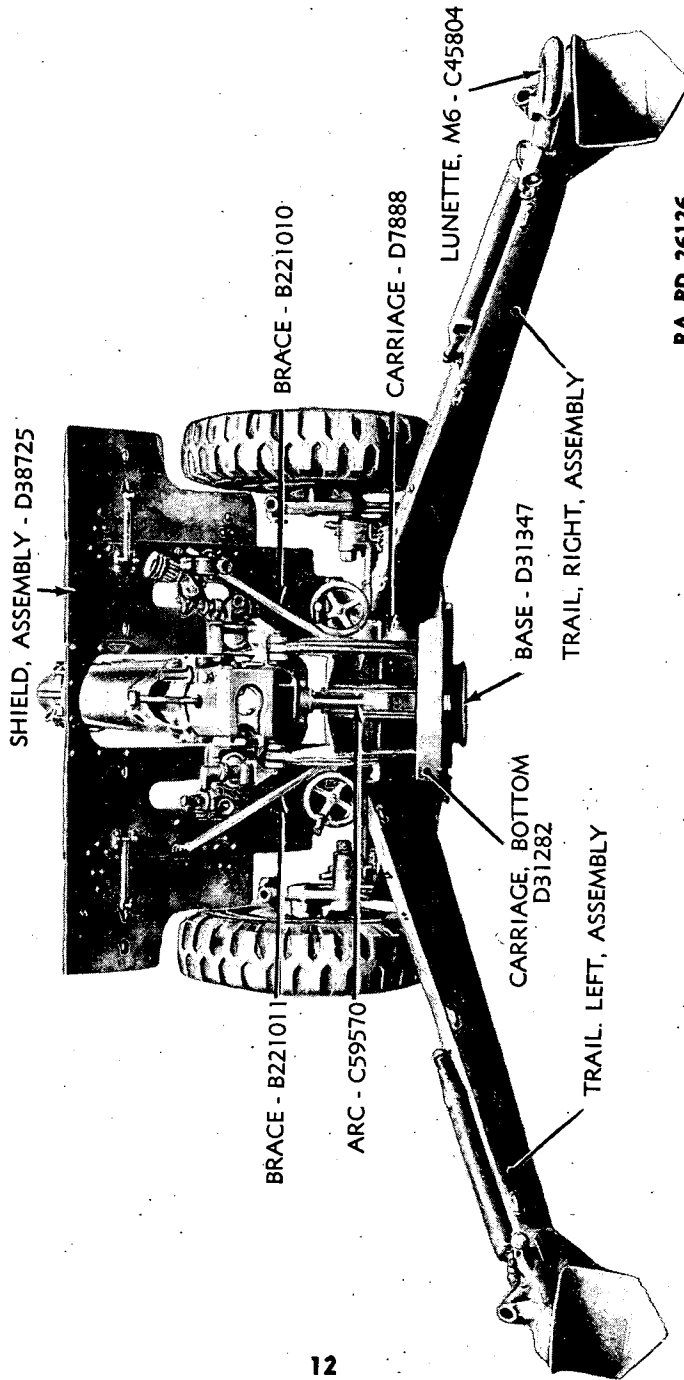

RA PD 26126

Figure 8—75-mm Pack Howitzer M1A1 and Carriage M3A3 in Firing Position—Rear View

INTRODUCTION

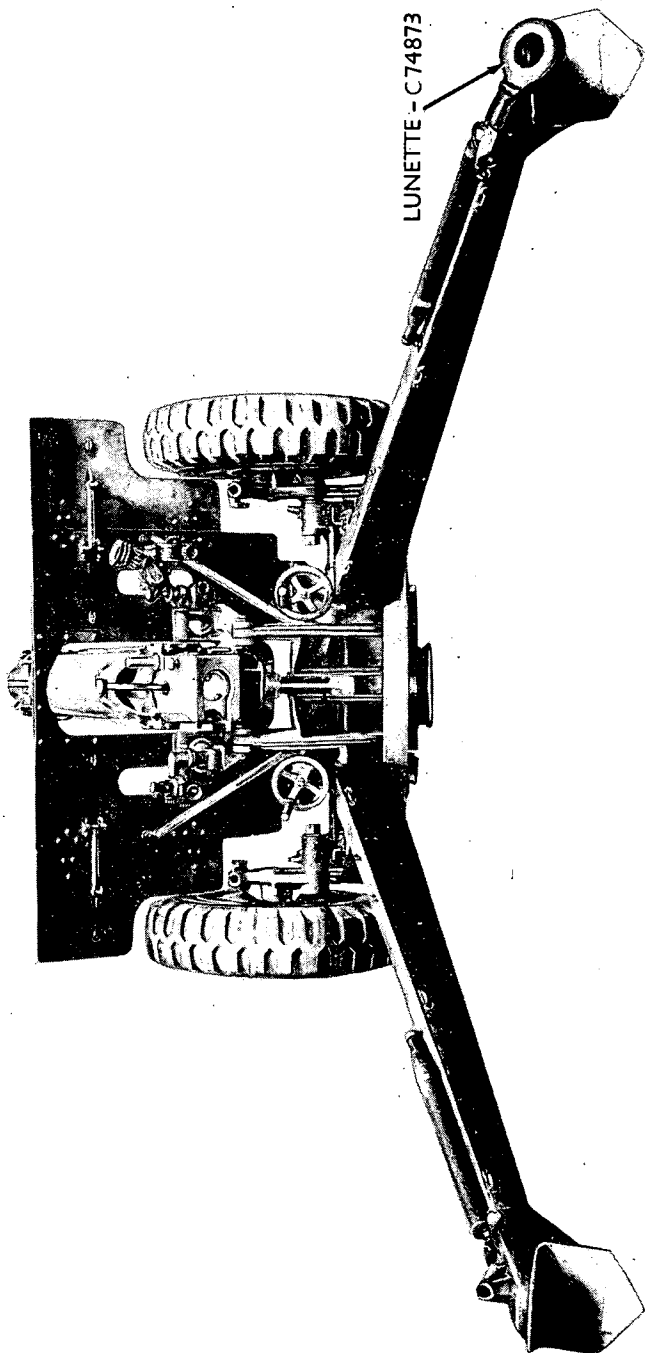

RA PD 26137

Figure 8a—75-mm Pack Howitzer M1A1 and Carriage M3A3 in Firing Position
With Modified Lunette—Rear View

ORDNANCE MAINTENANCE
75-MM HOWITZERS AND CARRIAGES



RA PD 26119

Figure 9—75-mm Pack Howitzer M1A1 and Carriage M3A3—Front View

INTRODUCTION

RA PD. 76705

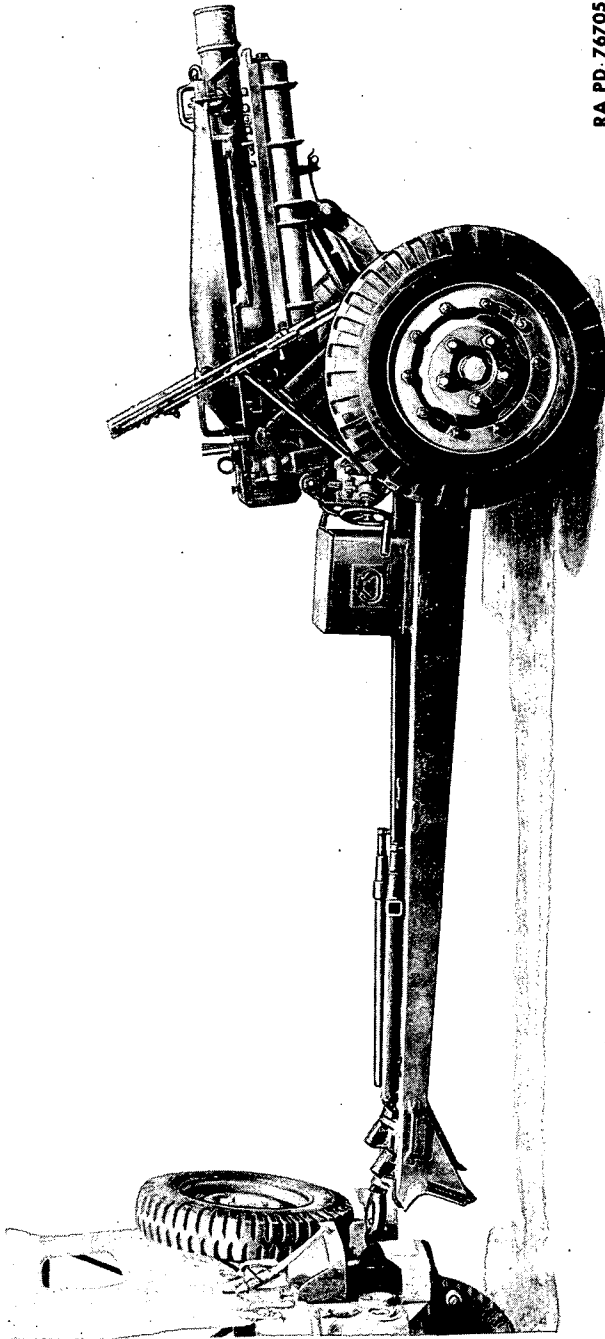

Figure 10—75-mm Pack Howitzer M1A1 and Carriage M3A3 in Traveling Position

**ORDNANCE MAINTENANCE
75-MM HOWITZERS AND CARRIAGES**

| | CARRIAGES | | |
|---|------------------------|------------------------|------------------------|
| | M1 (Pack) | M8 (Airborne) | M3A3 (Field) |
| Fire control equipment: | | | |
| Finder, range, 1-meter base model | M7 | M7 | M7 |
| Setter, fuse: | | | |
| Type | Hand | Hand | Hand |
| Model | M22 | M22 | M22 |
| | M14 (sub.) | M14 (sub.) | M14 (sub.) |
| NOTE: Refer to paragraph 3 for complete explanation of differences between M1, M8, and M3A3 Carriages: | | | |
| Fluid used, special recoil oil..... | 3 pt | 3 pt | 3 pt |
| Pressure at 70 F | 1,250 psi* | 1,250 psi* | 1,250 psi* |
| Length of recoil: | | | |
| Normal | 25 to 31 in. | 25 to 31 in. | 25 to 31 in. |
| Maximum | 32 in. | 32 in. | 32 in. |
| Metal-to-metal | 33.4 in. | 33.4 in. | 33.4 in. |
| Elevation: | | | |
| Maximum | (+45 deg) +800 mils | (+45 deg) +800 mils | (+50 deg) +887 mils |
| Minimum | (+5 deg) -89 mils | (+5 deg) -89 mils | (+9 deg) -160 mils |
| Elevation per turn at hand-wheel | 24 mils | 24 mils | 29.5 mils |
| Maximum when firing from wheels with trails closed | — | — | 380 mils |
| Traverse: | | | |
| Type | Axle | Axle | Pintle |
| Maximum, right | 3 deg | 3 deg | 22 deg 30 min |
| Maximum, left | 3 deg | 3 deg | 22 deg 30 min |
| Maximum total | (6 deg) 106 mils | (6 deg) 106 mils | (45 deg) 800 mils |
| Traverse per turn at hand-wheel | 4.1 mils | 4.1 mils | 24.7 mils |
| Maximum when firing from wheels with trails closed | — | — | 425 mils |
| Equilibrator: | | | |
| Type | Spring (2) | Spring (2) | Spring (2) |

*Pounds per square inch.

Section II

TOOLS AND EQUIPMENT FOR INSPECTION

5. TOOLS AND EQUIPMENT FOR INSPECTION.

a. The following tools and equipment are issued to Ordnance maintenance companies for use in the inspection of the 75-mm howitzer materiel.

Connection, pressure gage
(fig. 11).

The pressure gage connection is used in conjunction with the pressure gage when making a manometer test to determine compressed gas pressure and floating piston friction.

Gage, pressure, 200 kilograms
(fig. 11).

The pressure gage is used when making a manometer test to determine compressed gas pressure and floating piston friction.

Jack, screw, recoil piston
(fig. 11).

The recoil piston screw jack is used to force the recoil piston forward when making a manometer test.

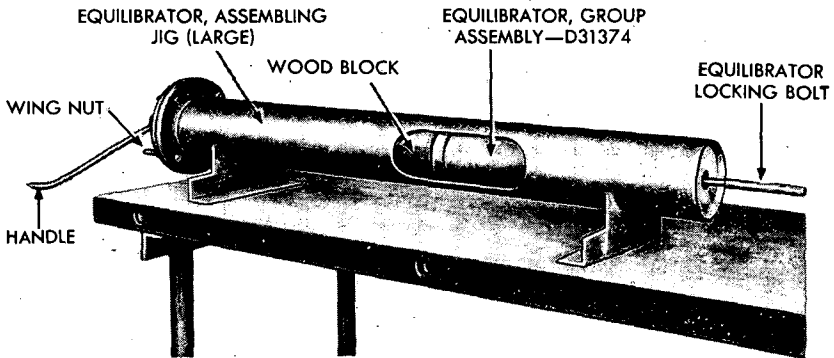

RA PD 26135

Figure 11—Inspection Tools for Recoil Mechanism

ORDNANCE MAINTENANCE 75-MM HOWITZERS AND CARRIAGES

Tester, pressure gage, complete (fig. 11).

The pressure gage testing apparatus, complete, is carried in the bottom of the special repair tool chest issued for Ordnance maintenance of the M1 and M8 Carriages. It is carried in a special chest as issued for Ordnance maintenance of M3A1, M3A2, and M3A3 Carriages. It is used for testing accuracy of service pressure gage C6385 (fig. 11) with master pressure gage B748 (fig. 12). Filled with liquid subjected to pressure by a screw, pressure is transmitted equally to both gages, causing gages to read the same when in adjustment.

To use tester, clamp in a vise by means of lug on under side (fig. 13). Screw is withdrawn and apparatus filled with recoil oil, before assembling pressure gage, to eliminate air bubbles in connections. Master gage is screwed in one arm of tester and gage to be tested into other arm. Apply pressure by operating screw and handle. Compare readings over entire range of gages. If gages are not in agreement, proceed as outlined below.

Adjust service pressure gage by pulling hand off spindle, using gage hand jack (fig. 14), and resetting hand in agreement with master gage reading. Use small hammer and gage hand set when resetting hand. *Tap very lightly* (fig. 15). Readings are between 430 and 2,300 pounds per square inch (30 to 160 kilograms per square centimeter).

TOOLS AND EQUIPMENT FOR INSPECTION

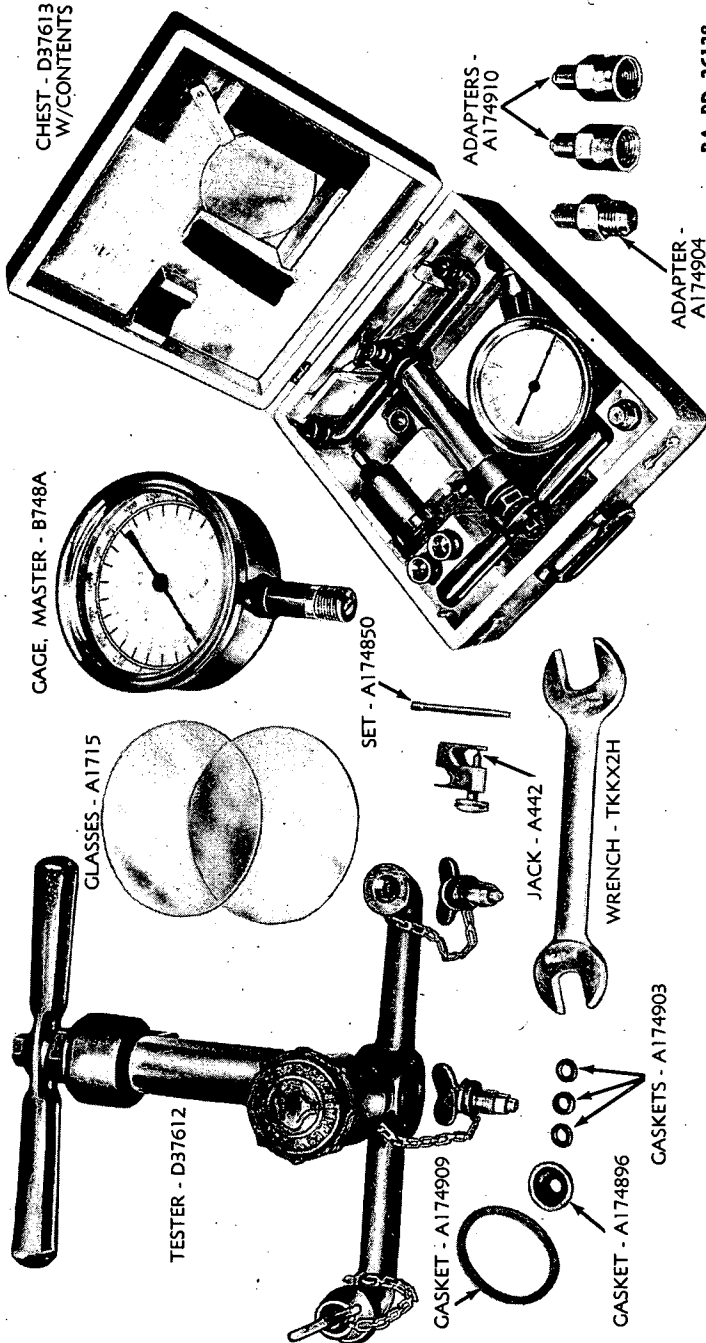

RA PD 26128

Figure 12—Pressure Gage Tester, Spare Parts, and Accessories

**ORDNANCE MAINTENANCE
75-MM HOWITZERS AND CARRIAGES**

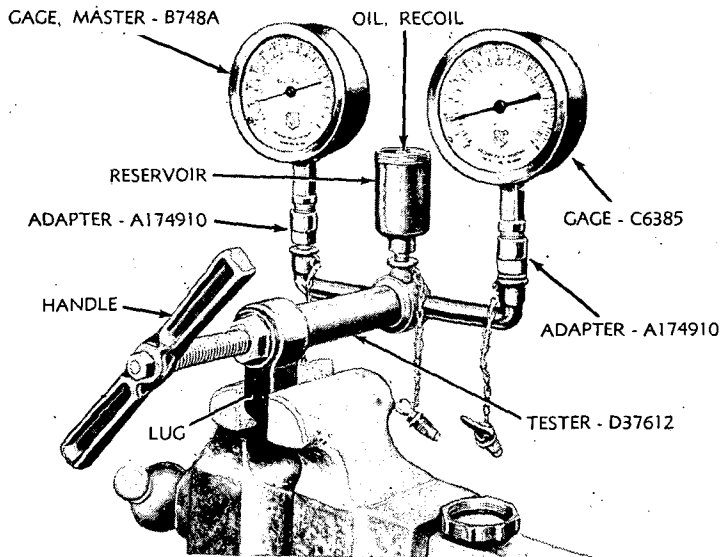

RA PD 26129

Figure 13—Testing Pressure Gage

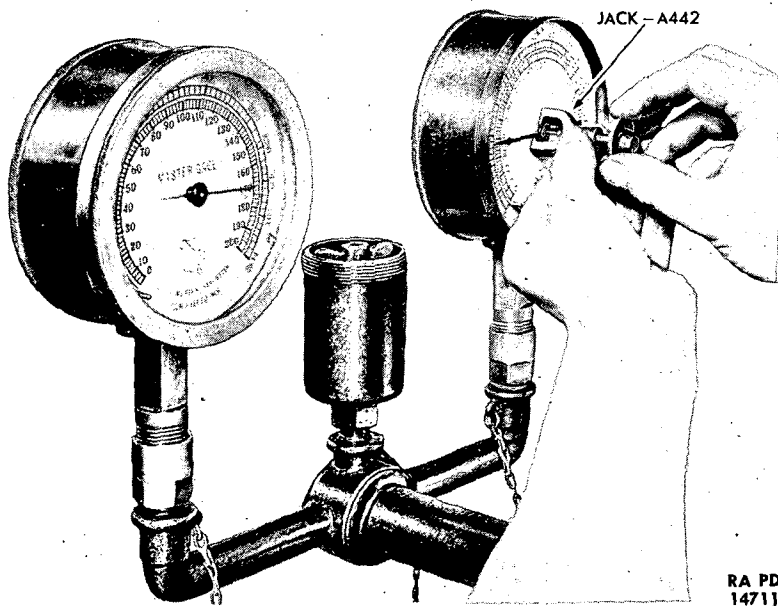

RA PD
14711

Figure 14—Removing Pressure Gage Hand

TOOLS AND EQUIPMENT FOR INSPECTION

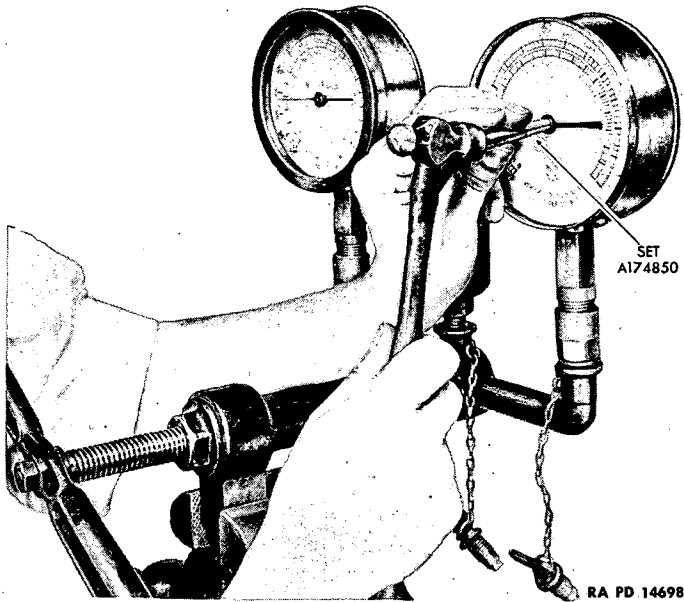

Figure 15—Resetting Pressure Gage Hand

b. The Following Items Are Part of the Pressure Gage Testing Apparatus:

Adapter A174910 (fig. 12).

Adapter A174904 (fig. 12).

Gage, pressure, master B748A
(fig. 12).

Gaskets A174909, A174896, and
A174903, and glasses A1715
(fig. 12).

Jack, gage hand A442
(fig. 12).

Used to connect gages to tester. Issued with all outfits, but used only with 155-mm and 240-mm howitzer materiel.

Used to check accuracy of service pressure gage. It is graduated in pounds per square inch as well as kilograms per square centimeter. This master gage should be calibrated annually or at any time there is doubt of its accuracy. Care must be exercised not to jar instrument unnecessarily.

The gaskets and glasses are spare parts.

Used to remove service pressure gage indicator hand, when not in agreement with master gage hand.

**ORDNANCE MAINTENANCE
75-MM HOWITZERS AND CARRIAGES**

Set, gage hand A174850
(fig. 12).

Used to place service pressure gage indicator hand in agreement with master gage hand.

Thermometer, Fahrenheit.

This thermometer is graduated from minus 20 degrees to plus 220 degrees. It is used for testing temperature of oil in recoil mechanism when making manometer test.

Section III

INSPECTION INSTRUCTIONS

6. PURPOSE.

a. Thorough, systematic inspection of the weapon is vital, and is the best protection against an unexpected breakdown at a critical moment, when maximum performance is absolutely necessary.

b. Primary Aims of Inspection Are:

(1) To detect faulty or careless preventive maintenance, especially inadequate lubrication.

(2) To determine whether adjustment, repair, or replacement of parts is necessary.

(3) To verify that all modifications authorized by Modification Work Orders have been made.

7. GENERAL INSPECTION PROCEDURE.

a. Inspection should always be accompanied by corrective measures to remedy any deficiencies or defects found.

b. When any part of the weapon is turned over to ordnance, it will be ascertained before reissue to troops that critical examination has been made, and that all imperfections have been corrected as outlined in paragraph 6 b, above, in so far as conditions permit.

c. The results of inspection should be noted in the Artillery Gun Book (O.O. Form 5825). Any unusual condition which might result in improper operation, damage to materiel, or injury to personnel, will be remedied immediately.

d. Suggested improvements in design and maintenance, and safety and efficiency of operation prompted by chronic failure or

INSPECTION INSTRUCTIONS

malfunction of the weapon, spare parts, or equipment should be forwarded to the Office of the Chief of Ordnance, Field Service Division, Maintenance Branch, with all available pertinent information. Such suggestions are encouraged in order that other organizations may benefit. *CAUTION: No modification of materiel will be made unless authorized.*

e. Reference should be made frequently to the Inspection Sections in TM 9-319 and TM 9-320, each of which contains a list of inspections which the using arms are required to perform. Only inspections which the using arms are not equipped for, or permitted to make, are described here.

f. Howitzer.

**Parts To Be Inspected in
Order of Inspection**

Points To Be Observed

Tube (par. 20).

Evidence of powder fouling and rust.

Erosion of tube (par. 11).

Wear and deformation of lands and grooves (star-gage, par. 10), pitting and pastilles (par. 11).

Condition of breech ring attaching threads.

Condition of eyebolt.

Breech ring for fit on tube.

Breech ring threads for scores or bruises.

Breech recess for burs, scoring, or bruises on bearing surfaces.

Condition of eyebolt.

Scored or bruised leveling plates.

In accordance with War Department Circular No. 209, 1943, all dates of manufacture, inspection, acceptance, delivery, and other dates peculiar to individual items, should be eliminated from all aircraft and airborne equipment. Obliterating the date by peening is not satisfactory. It should be removed by grinding and polishing.

Breech ring (par. 21).

Proper amount of oil in the system (TM 9-319 or TM 9-320).

Operation of oil index.

g. Recoil Mechanism Including Bottom Sleigh (pars. 24 and 12).

**ORDNANCE MAINTENANCE
75-MM HOWITZERS AND CARRIAGES**

**Parts To Be Inspected in
Order of Inspection**

Points To Be Observed

**h. Carriages.
General.**

Top sleigh (par. 26).

Bottom sleigh (par. 24).

Examine for excessive oil leakage past the packing of recoil piston, recoil piston rod stuffing box, oil index, and filling and drain valve. Normally, a slight leakage of discolored oil past the packing of the recoil piston and the recoil piston rod stuffing box is in evidence. This slight leakage past these two packings insures lubrication.

Check gas pressure (par. 13).

Check floating piston friction (par. 13).

Check recoil piston and recoil stuffing box friction (par. 13).

Respirator in recoil cylinder rear head clean and operating properly.

Examine the sleigh guides for scores or bruises.

Operation of recoil indicator.

Condition of all welds, rivets, bolts, and screws.

Lubrication fittings have a red circle painted around them.

Lubrication fittings clean and functioning.

Carriage painted in accordance with regulations.

No loose, broken, or missing bolts, nuts, screws, or cotter pins.

Check condition of top sleigh. Note whether cracked or broken.

Check operation of top sleigh clamping latch.

Condition of top sleigh front and rear hooks. Note whether burred or roughened.

See subparagraph g, above.

INSPECTION INSTRUCTIONS

| Parts To Be Inspected in Order of Inspection | Points To Be Observed |
|---|--|
| Cradle (pars. 27 and 36). | Check condition of cradle. Note whether sprung, bent, or damaged. |
| | Examine for broken or cracked welds. |
| | Examine slides for scores or rough spots. |
| | Front and rear trunnion pins for wear, scores, and tightness. |
| | Piston rod latch and latch lever for operation and condition. |
| | Sight bracket mechanism for operation and condition. |
| | Cradle lock for condition and operation (M3A3). |
| Elevating mechanism (pars. 29 and 39). | Ease and smoothness of operation through complete range. |
| | Elevating crank backlash (M1 and M8). Elevating handwheel backlash (M3A3). |
| | Rocker assembly for worn or damaged teeth (M1 and M8). Elevating arc for worn or damaged teeth (M3A3). |
| | Bevel pinion gears, worm wheels, and worms for worn or damaged teeth. |
| | Flexible joints for condition (M3A3). |
| | All bearings and bushings for wear or damage. |
| Traversing mechanism (pars. 30 and 37). | Check operation through complete range. |
| | Check for handwheel backlash. |
| | Examine traversing rack for worn or damaged teeth (M3A3). |
| | Check worm, worm wheel, and gears for worn or damaged teeth (M3A3). |
| | Flexible joint for condition (M3A3). |
| | All bearings and bushings for wear or damage. |

**ORDNANCE MAINTENANCE
75-MM HOWITZERS AND CARRIAGES**

**Parts To Be Inspected in
Order of Inspection**

Equilibrators (pars. 28 and 35).

Top carriage (M3A3)
(par. 38).

Bottom carriage (M3A3)
(par. 40).

Trails (par. 42).

Brake mechanism (M3A3)
(par. 41).

Points To Be Observed

Check action of equilibrators by depressing and elevating howitzer through complete range.

Examine equilibrator springs for breakage.

Examine the barrel of the equilibrators for rough or scored walls (M3A3).

Check operation of top carriage.

Examine for cracks or damage.

Pintle pin bushings and pintle pin for wear or scores.

Examine for cracks or damage.

Check wheel carrier bushings for wear or damage.

Operation of wheel latch.

Firing base lock for operation and condition.

Examine trails, and all supports and fastenings welded to trails, for defects.

Check condition of axle bearings (M1 and M8).

Examine trail connecting mechanism for operation and condition.

Check condition of hinges, spades, spade points, lunette and straps, and fastenings.

Note that the trails swing freely and that the trail hinge pins are properly lubricated (M3A3).

Check the brakes by placing carriage in firing position. Set the brake levers and note position of brake ratchet pawl on brake rack. If in last tooth, adjust brake (par. 41).

Release brake levers and rotate wheels. Check for possible drag.

Check brake lining for wear or damage.

Check brake drums for scoring.

INSPECTION INSTRUCTIONS

| Parts To Be Inspected in Order of Inspection | Points To Be Observed |
|---|---|
| Wheels and tires (pars. 32 and 41) | <p>Check disk and rims for dents or distortion (M8 and M3A3).</p> <p>Note disk and rim wheel nuts for condition and tightness (M8 and M3A3).</p> <p>Check tires for wear and proper pressure (M8 and M3A3).</p> <p>Check wheel bearings for condition (M8 and M3A3).</p> <p>Check hub liners for condition (M1 and M8).</p> |
| <p>Wheel carriers (M3A3) (par. 40).</p> <p>Firing base (M3A3) (par. 40).</p> <p>Shields (M3A3) (par. 34).</p> | <p>Check wheel carriers for operation and condition.</p> <p>Check for condition.</p> <p>Examine shields for damage.</p> <p>Open and close right and left shield wings and check operation and condition of hinges and locks.</p> <p>Check braces for condition and tightness.</p> <p>Examine all bolts, screws, and rivets for condition and tightness.</p> <p>Correct lubricants used in accordance with the proper lubrication order.</p> |
| Lubrication | <p>Check inspection and special repair tools against list of contents pasted on under side of special repair tool chest lid or against list given in SNL C-18.</p> |
| Inspection and repair tools. | <p>Inspection and special repair tools are of such design that, with proper handling and storage in respective containers, they will require little care. Inspect each tool before and after use, and remove all burs with a smooth file or oilstone. When placed in container, apply a light film of SAE 30 engine oil, above +32°F, SAE 10 from +32°F to 0°F, or special preservative lubricating oil, below 0°F.</p> |

**ORDNANCE MAINTENANCE
75-MM HOWITZERS AND CARRIAGES**

8. ARTILLERY GUN BOOK (O.O. FORM 5825).

a. Complete instructions for use are contained in the book. The gun book must accompany weapon at all times and be available to inspectors. Instructions must be carried out and posted in spaces provided.

b. Should the gun book be lost and the original star-gage report be unobtainable, the inspector may assume that the lands of the 75-mm Howitzer Tube M1 or M1A1, 35.75 inches from the muzzle, were within the manufacturing limit of plus 0.004 inch on the normal dimension of 2.950 inches at the time of proof firing. If a star-gage reading 2.960 inches is obtained (an increase of 0.10 inch over the maximum size of 2.950 inches for a new tube), the remaining life of the howitzer tube may be appraised between 5,000 to 6,000 rounds.

9. AVERAGE LIFE OF HOWITZER TUBE.

a. The average life of the howitzer tube is approximately 12,000 rounds. The howitzers in service should be star-gaged after approximately 90 percent of their estimated accuracy life and thereafter at each 10 percent during the remainder of their service.

b. Tubes are star-gaged any time an inspector may find it advisable due to unusual wear or other irregularities in the bore. Decoppering of bores of tubes is prohibited.

10. STAR-GAGING.

a. Star-gaging equipment is not issued to all Ordnance maintenance companies, but may be obtained from a heavy Ordnance maintenance company or the Army inspector of artillery.

b. Instructions for star-gaging will be found in TM 9-1860.

c. When star-gaging equipment is not available, the inspection report on "diameter of the bore at a point 35.75 inches from the muzzle" must be recorded as "not taken." The point of maximum wear of the lands is 35.75 inches from the muzzle.

11. INSPECTION OF HOWITZER TUBE.

a. The effect of scratches, nicks, pitting, scoring, etc., in the bore, caused by accidents, local defects of the bore, and improper care, are as follows: They permit leakage of gas past the rotating band of the projectile and thereby promote erosion of the bore. They also wear away the rotating band so that the projectile does not attain its proper rotational velocity. Such defects should be smoothed and

INSPECTION INSTRUCTIONS

rounded, and depending on their location, character, and extent, it should be determined whether such defects are apt to cause further damage due to gas leakage and wear on the rotating bands. No definite rule can be used in making this decision. Tubes badly scored beyond the forcing cone must be reported to the Chief of Ordnance for final action.

CAUTION: Experience has shown that the wear of a tube of small caliber, such as the 75-mm, is a factor of so many variables that condemnation on any single basis is unwise. The limits previously given should be used only as a general guide, and a howitzer should be condemned only after careful consideration of each of the factors involved. It is evident that a tube is still serviceable in spite of numerous bore defects, if its dispersion is not great enough to endanger troops advancing under cover of a barrage, or to cause waste of ammunition.

b. **Pastilles.** The effect of pastilles upon the safety and accuracy of the tube is negligible so far as can be determined. However, as a precautionary measure, tubes having more than three pastilles the size of a 5-cent piece, must be withdrawn from service.

c. **Deformation of Rifling.** Deformation of the rifling at the origin, in general, consists of sheared lands and a flow of metal in the grooves, so that the pitch of the rifling for the first inch or two is considerably reduced. This is a serious defect, and tubes showing it to a marked degree are not to be reissued.

d. **Bore Impressions.** Impressions are desirable for accurate measurements. Before making impressions, clean the surface and make all preparations prior to mixing the calcined gypsum, which sets rapidly. Mix calcined gypsum, grade I, with water, thin enough to flow readily, and pour immediately, confining the material to the desired location by a wall of wood, or other suitable substance. After pouring, allow to harden and set from 1 to 1½ hours before removal.

e. **Interchangeability of Barrels in Their Respective Breech Rings.** When circumstances are such that the barrel cannot be separated from the breech ring, and a complete cannon must be substituted for an unserviceable barrel, cut off the old barrel about 3 inches from the breech ring.

12. INSPECTION OF RECOIL MECHANISM.

a. **General.** The recoil mechanism should be inspected for oil leakage, pressure of compressed nitrogen, friction of the various packings, serviceability of oil index, and condition of sleigh slides (fig. 16).

ORDNANCE MAINTENANCE
75-MM HOWITZERS AND CARRIAGES

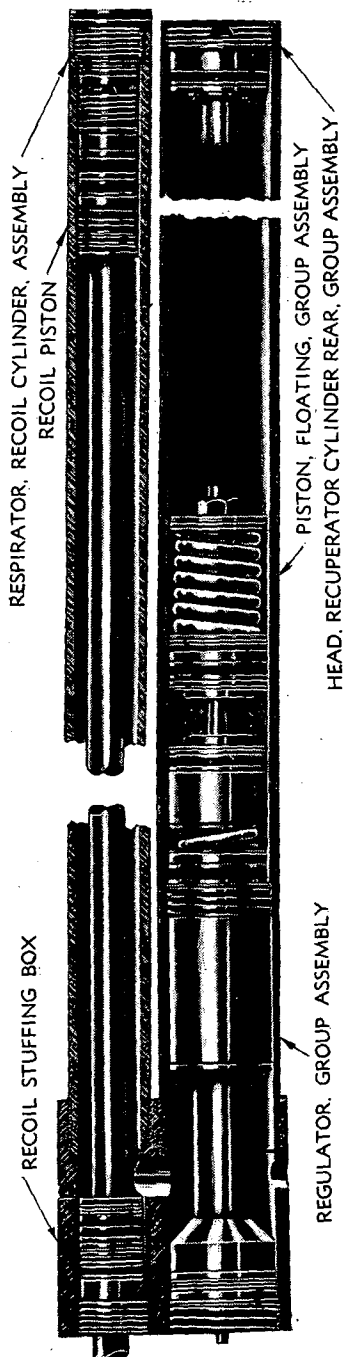

RA PD 73150

Figure 16—75-mm Howitzer Recoil Mechanism M1A4—Schematic View

INSPECTION INSTRUCTIONS

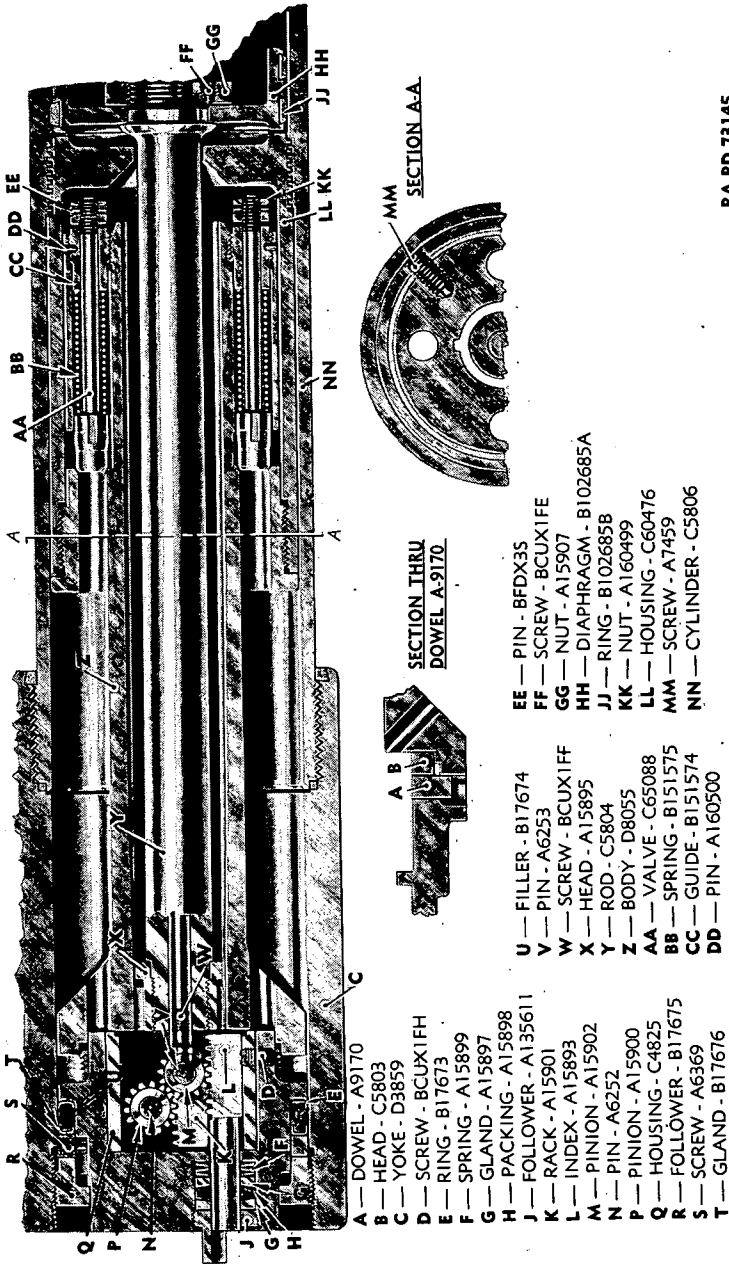

RA PD 73145

Figure 17—75-mm Howitzer Recoil Mechanism M1A4—Regulator and Oil Index

- A — DOWEL - A9170
- B — HEAD - C5803
- C — YOKE - D3859
- D — SCREW - BCUX1FH
- E — RING - B17673
- F — SPRING - A15899
- G — GLAND - A15897
- H — PACKING - A15898
- J — FOLLOWER - A135611
- K — RACK - A15901
- L — INDEX - A15893
- M — PINION - A15902
- N — PIN - A6252
- P — PINION - A15900
- Q — HOUSING - C4825
- R — FOLLOWER - B17675
- S — SCREW - A6369
- T — GLAND - B17676
- U — FILLER - B17674
- V — PIN - A6253
- W — SCREW - BCUX1FF
- X — HEAD - A15895
- Y — ROD - C5804
- Z — BODY - D8055
- AA — VALVE - C65088
- BB — SPRING - B151575
- CC — GUIDE - B151574
- DD — PIN - A160500
- EE — PIN - BFDX35
- FF — SCREW - BCUX1FE
- GG — NUT - A15907
- HH — DIAPHRAGM - B102685A
- JJ — RING - B102685B
- KK — NUT - A160499
- LL — HOUSING - C60476
- MM — SCREW - A7459
- NN — CYLINDER - C5806

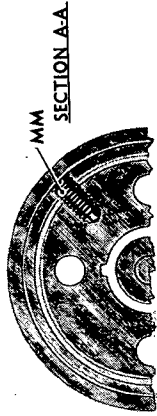

ORDNANCE MAINTENANCE
75-MM HOWITZERS AND CARRIAGES



RA PD 80033

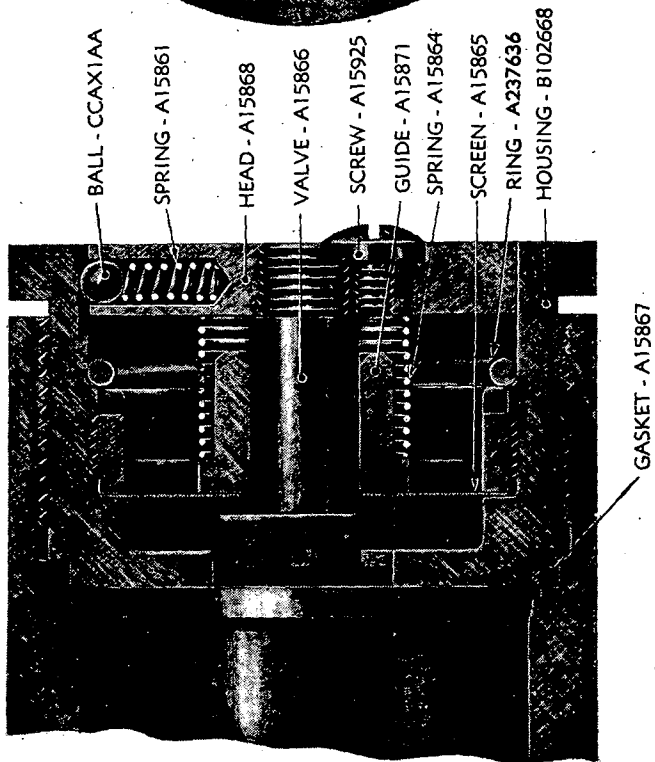
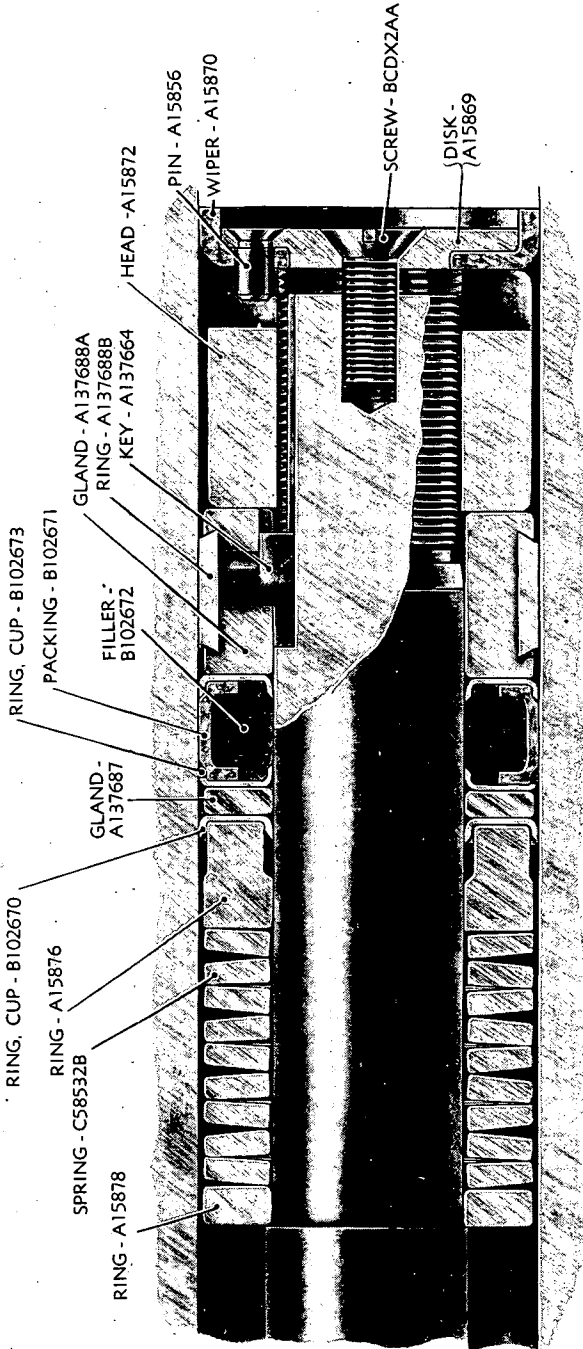

Figure 18—75-mm Howitzer Recoil Mechanism M1A4—Respirator

INSPECTION INSTRUCTIONS



RA PD 73148

Figure 19—75-mm Howitzer Recoil Mechanism M1A4—Recoil Piston

ORDNANCE MAINTENANCE
75-MM HOWITZERS AND CARRIAGES

- A — FOLLOWER - A15852
- B — HEAD - B103501
- C — WIPER - A15853
- D — GLAND - A137689A
- E — KEY - A137664
- F — RING - A137689B
- G — RING - B102663
- H — PACKING - B102664
- J — FILLER - B102665
- K — RING - B102666
- L — GLAND - A15857
- M — RING - A137690
- N — SPRING - C58532A
- P — RING - A15860

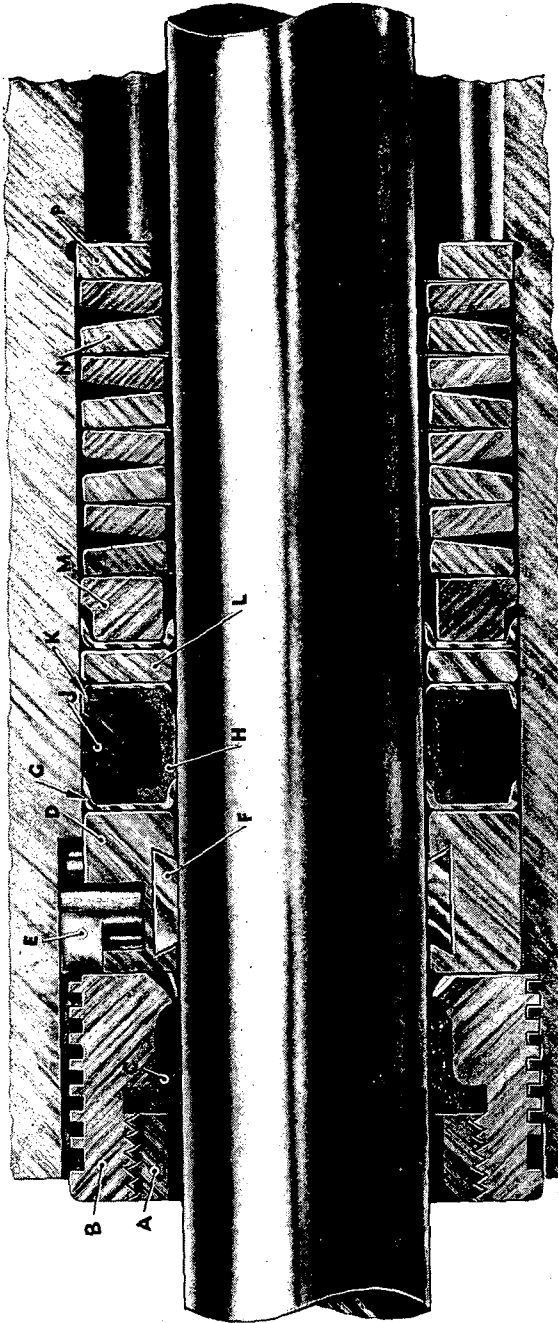

RA PD 73149

Figure 20—75-mm Howitzer Recoil Mechanism M1A4—Stuffing Box

INSPECTION INSTRUCTIONS

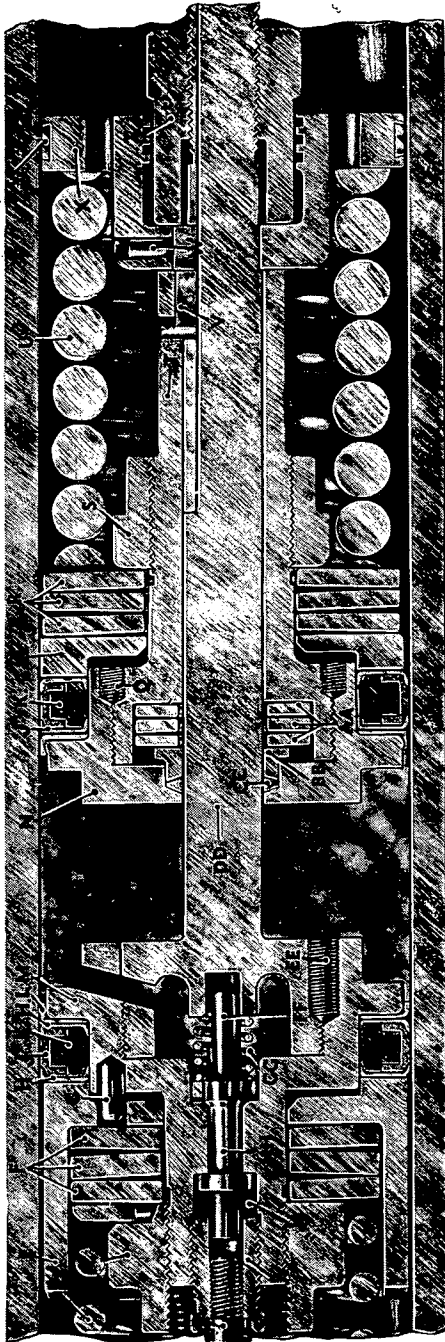

- A — RETAINER - B13891
- B — ROD - A15894
- C — NUT - A15905
- D — SPRING - B158473
- E — GLAND - B102680
- F — SPRING - A15906
- G — PIN - A15908
- H — RING - B102681
- J — PACKING - B102683
- K — FILLER - B102682
- L — RING - B102684
- M — HEAD - C5801

- N — BOX - B102686
- P — GLAND - A15923
- Q — SCREW - BCUX1FF
- R — SPRING - A15922
- S — NUT - A15917
- T — GUIDE - C6563
- U — SPRING - A171625
- V — KEY - A15920
- W — KEY - A15921
- X — HEAD - B102688A
- Y — RING - B102688B

- Z — NUT - A17666
- AA — SPRING - A15916
- BB — GLAND - A15915
- CC — PACKING - A15924
- DD — STEM - B102689
- EE — SCREW - A15914
- FF — VALVE - A15912
- GG — SPRING - A15909
- HH — SEAL - A15687
- JJ — GASKET - A9578

RA PD 73144

Figure 21—75-mm Howitzer Recoil Mechanism M1A4—Floating Piston

**ORDNANCE MAINTENANCE
75-MM HOWITZERS AND CARRIAGES**

b. **Oil Index.** To test the reliability of the oil index, insert the oil release in the oil filling and drain valve hole, located on the right side near the front end of the recoil cylinder. Drain the reserve oil. The oil index should start to move in before the oil ceases to flow, and should recede within the oil index follower when the reserve is exhausted (fig. 17). Refill the mechanism as outlined in TM 9-320 or TM 9-319. The oil index should start to move out after about five revolutions of the oil screw filler. While injecting the oil, tap the oil index lightly on each turn of the oil screw filler. If the index does not move out after about half the capacity of the oil screw filler has been injected, it is an indication that there is something wrong with the mechanism. Correct as outlined in paragraph 24.

c. **Oil Reserve.** The oil reserve is that oil which separates the diaphragm and floating piston when the weapon is in battery. With an oil reserve established, the pressure of the nitrogen is transmitted to the oil; and consequently to the recoil piston and rod, returning the howitzer to battery and holding it there at all angles of elevation. This amount of oil is approximately one-half an oil screw filler full, or the amount required to cause a properly working oil index to move through its extremes of movement. The maximum outward position of the oil index is with the front face of the index flush with the extension on the oil index packing follower. The forcing of additional oil to increase nitrogen pressure is *definitely forbidden*.

d. **Oil Leakage.**

(1) Remove the recoil cylinder rear head (respirator assembly) (fig. 18). If clear oil is present, it indicates a leak past the recoil piston (fig. 19). Correct as outlined in paragraph 24.

(2) Examine the face of the oil index follower for indication of oil leakage (fig. 17). If a leak is present, tighten slightly on the follower, using great care not to bind the oil index. If leakage continues, renew the oil index packing (par. 24).

(3) Examine the seat between the recoil and recuperator cylinders entering the yoke assembly. If an oil leak is present, the mechanism should be sent to base shop for repair.

e. **Sleigh Slides.** Examine for burs or scoring. When found, correct as outlined in paragraph 24.

13. MANOMETER TEST.

a. In order that an intelligent and consistent inspection may be made of the recoil mechanism, it is essential that the inspector be informed not only as to its action but also with regard to certain of its technical peculiarities with which he will come in contact. There-

INSPECTION INSTRUCTIONS

fore, examination for excessive oil leakage past the packing of the recoil piston, recoil piston rod, stuffing box, oil index, and filling and drain valve should be made. Normally a slight leakage of discolored oil past the packing of the recoil piston and the recoil piston rod stuffing box is in evidence. The slight leakage past these two packings insures lubrication (figs. 19 and 20).

b. General Tests.

(1) "Oil reserve" or "reserve oil" are terms applied to that portion of the oil which normally separates the floating piston from the diaphragm. Referring to the sectioned view (fig. 16), it will be apparent that the compressed nitrogen acts to put pressure on the oil only so long as there is oil between the diaphragm and the floating piston. After these components come in contact, further movement of the floating piston is prevented and, consequently, the pressure of the oil will drop to zero. In amount, the reserve oil represents a volume corresponding to a movement of the floating piston of about three-eighths inch, or exactly the same as the travel of the oil index between its extremes of movement.

(2) In determining the nitrogen pressure, the inspector is actually measuring the pressure on the oil transmitted to it by the compressed gas through the medium of the floating piston (figs. 16 and 21).

(3) The oil, in passing from the vicinity of the pressure gage to the vicinity of the floating piston, or vice versa, must pass through very small orifices. Because of the resistance offered in these orifices, if the recoil piston jack is operated rapidly in either direction, a misleading pressure will be generated in the vicinity of the gage and registered thereon. For this reason the recoil piston jack screw must be operated at not more than four turns per minute.

(4) The oil within the mechanism becomes sluggish at a low temperature. Its action through the small orifices is, therefore, erratic, and the reliability of the gas pressure measurements under such conditions is always doubtful. Therefore, if pressures must be taken in cold weather, it is necessary that the recoil mechanism and extra oil be in a room warmed to at least 50 F for 24 hours preceding the test.

(5) Since the amount of nitrogen gas originally placed in the mechanism cannot increase, the pressure at any given temperature cannot become higher except by moving the floating piston forward so as to reduce the volume of the gas chamber. This can be accomplished if an excess of oil is introduced, as may be the case if the oil index is stuck and the sticking is not noticed. Make sure the oil index is registering properly by draining off some of the reserve oil and then restoring it. The oil index will move in when the oil is

ORDNANCE MAINTENANCE 75-MM HOWITZERS AND CARRIAGES

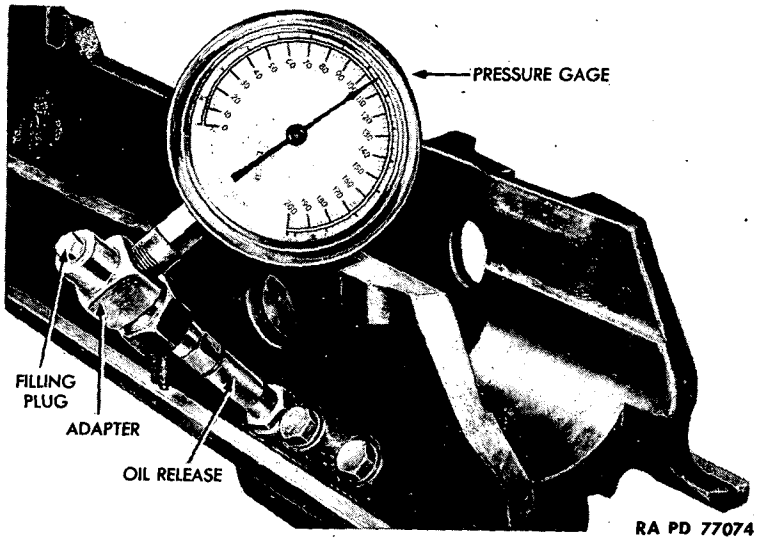

Figure 22—Checking Gas Pressure in Recoil Mechanism

drained and should move out as the reserve is reestablished. Failure of the oil index is almost invariably on the outward movement.

(6) If gas leaks past the floating piston, it may be detected by the foamy appearance, and the sputtering of the oil, when draining off the reserve oil.

(7) Place the bottom sleigh (recoil mechanism) in a horizontal position. Remove the filling and drain plug located in the yoke. Connect the oil release (fig. 22). As the oil release is screwed in, the reserve oil is released and should be caught in the thermometer. The reserve oil should be allowed to flow until the flow of oil practically ceases. The oil index should move inward beyond the face of the oil index follower.

(8) Make a record of the temperature. Keep the thermometer out of the sun. This should represent as accurately as possible the temperature inside the recoil mechanism.

(9) Disassemble the pressure gage connection by unscrewing the large hexagonal nut. Attach the smaller part of the connection to the oil release, and attach the pressure gage to the larger part of the connection. Assemble the two parts of the connection to the oil release, being careful not to break off the oil release in the filling valve. Make all joints tight enough to hold a pressure of approximately

INSPECTION INSTRUCTIONS



Figure 23—Removing Respirator Assembly

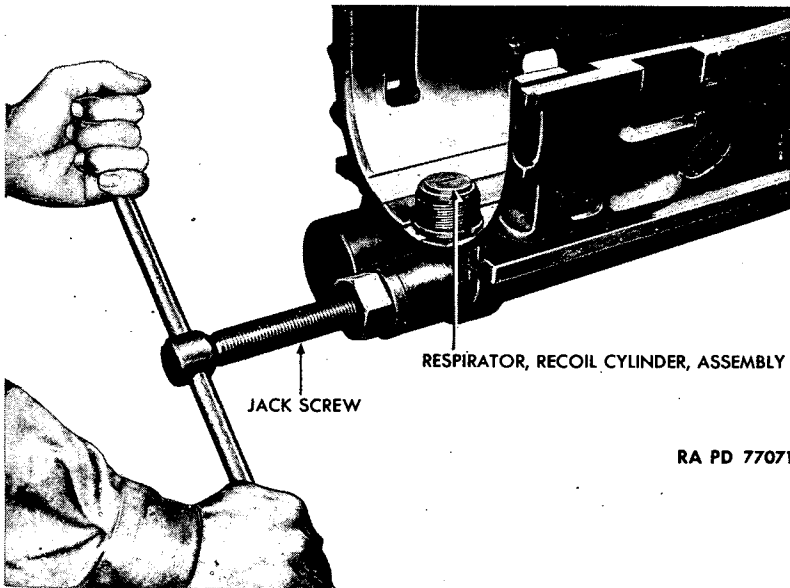

Figure 24—Using Jack Screw on Manometer Test

ORDNANCE MAINTENANCE 75-MM HOWITZERS AND CARRIAGES

1,700 pounds per square inch. Screw the filling plug *loosely* into the end of the pressure gage connection.

(10) Unscrew the respirator from the rear end of the recoil cylinder, using wrench B104035, modified by removing the screw A18572 and filing or grinding the $\frac{1}{2}$ -inch slot one-sixteenth inch deep which is necessary to clear the head of the screw A15925 of the respirator assembly C5794.

(11) Retract the screw of the recoil piston screw jack B102874 in the nut until the cap on the screw contacts the nut, then screw the nut firmly into the cylinder. This method of assembling the screw jack is necessary to prevent scratching the recoil cylinder walls with the recoil piston screw jack.

(12) Purge the line of air by forcing the recoil piston to the rear by means of the recoil piston screw jack, and by forcing oil and air out the end of the pressure gage connection into which the filling plug has been screwed loosely. When the oil flows free of all air bubbles tighten the filling plug into the pressure gage connection.

c. To Determine Nitrogen Pressure and Friction of Floating Piston.

(1) Move the recoil piston forward by means of the recoil piston screw jack until the oil index indicates that there is a full oil reserve in the recoil mechanism.

NOTE: It is necessary that the oil index be operating properly. Check it in accordance with paragraph 12 b. When the oil index is out until it protrudes flush with the extension on the oil index follower, read the pressure gage *while the piston jack is in motion*. This reading represents the gas pressure plus the friction of the floating piston ($AP + F$). Make a note of the gage reading.

(2) Continue turning the jack screw five more revolutions, then reverse the direction of the jack screw, unscrewing for five revolutions, moving at a rate of four turns per minute. On the fifth revolution, and while the piston screw jack is in motion, read the gage a second time. This reading represents the nitrogen pressure minus the friction of the floating piston ($AP - F$). Make a note of the reading.

(3) It is necessary that the above readings be taken a sufficient number of times to obtain three consecutive uniform readings. The average of three uniform readings of $AP + F$ and three uniform readings of $AP - F$ will be used for making the final computation of the nitrogen pressure (AP) and the friction of the floating piston (F).

INSPECTION INSTRUCTIONS

(4) It must be remembered that it is the sliding friction of the floating piston, and not the standing friction, that is to be deducted. Therefore the floating piston must be in motion (the piston screw jack must be turning) when the reading is taken on the pressure gage.

(5) The nitrogen pressure in the mechanism is one-half the sum of the $AP + F$ and $AP - F$ readings.

$$AP = \frac{(AP + F) + (AP - F)}{2}$$

EXAMPLE:

$AP + F$ reading = 1,435 pounds per square inch.

$AP - F$ reading = 1,065 pounds per square inch.

Add these readings together = 2,500

Divide the answer by 2 = 1,250

1,250 pounds per square inch is the nitrogen pressure of the recoil mechanism.

(6) The friction of the floating piston is one-half the difference between $AP + F$ and $AP - F$ reading.

$$F = \frac{(AP + F) - (AP - F)}{2}$$

EXAMPLE:

$AP + F$ reading = 1,435 pounds per square inch.

$AP - F$ reading = 1,065 pounds per square inch.

Subtract the $AP - F$ reading from the $AP + F$ reading. The result is 370 pounds per square inch, or twice the friction of the floating piston. Divide 370 by 2, and the result is 185 pounds per square inch. This is the friction of the floating piston.

(7) The friction of the floating piston, and the friction of the recoil piston and stuffing box in mechanisms that have been assembled for considerable periods will increase to high friction owing to the absorption of oil by the packings. The normal pressure to overcome the friction of the floating piston is 185 pounds per square inch. The friction of the floating piston may vary between the limits of 125 and 400 pounds per square inch. If not within these limits, and exercise of the mechanism fails to lower frictions, the condition of the mechanism will be reported to the Chief of Ordnance.

d. To Correct the Nitrogen Pressure for Temperature Variation.

(1) The recoil mechanism was initially charged with nitrogen at a pressure of 1,250 pounds per square inch without reserve (floating piston in direct contact with diaphragm).

**ORDNANCE MAINTENANCE
75-MM HOWITZERS AND CARRIAGES**

NOTE: The change in nitrogen pressure when a full oil reserve is added is inconsequential, since it does not affect the service pressure gages.

(2) The nitrogen pressure varies directly in proportion with the *absolute* temperature. Since absolute zero is -460°F , 70°F is 530°F absolute temperature.

(3) 1,250 divided by 530 is 2.36 pounds per square inch change in pressure for each degree Fahrenheit change in temperature.

EXAMPLE: Temperature of the recoil mechanism is 84°F .

$$84 - 70 = 14$$

$$14 \times 2.36 = 33 \text{ pounds per square inch.}$$

$$1,250 + 33 = 1,283 \text{ pounds per square inch}$$

(the correct nitrogen pressure for 84°F).

Temperature of recoil mechanism is 61°F .

$$70 - 61 = 9$$

$$9 \times 2.36 = 21 \text{ pounds per square inch.}$$

$$1,250 - 21 = 1,229 \text{ pounds per square inch}$$

(the correct nitrogen pressure for 61°F).

(4) The correct nitrogen pressures at various temperatures may be found by referring to the table below:

| Temperature (deg F) | Pressure (lb per sq in.) | Temperature (deg F) | Pressure (lb per sq in.) |
|------------------------|-----------------------------|------------------------|-----------------------------|
| 50 | 1,203 | 100 | 1,321 |
| 55 | 1,215 | 105 | 1,333 |
| 60 | 1,226 | 110 | 1,344 |
| 65 | 1,238 | 115 | 1,356 |
| 70 | 1,250 | 120 | 1,368 |
| 75 | 1,262 | 125 | 1,380 |
| 80 | 1,274 | 130 | 1,392 |
| 85 | 1,285 | 135 | 1,403 |
| 90 | 1,297 | 140 | 1,415 |
| 95 | 1,309 | | |

NOTE: The recoil mechanism is considered serviceable with a variation of plus or minus 50 pounds per square inch. If not within these limits, the condition of the recoil mechanism with full details must be reported to the Chief of Ordnance.

e. To Determine Friction of Recoil Piston and Recoil Piston Rod Stuffing Box.

(1) Force the recoil piston to the rear (about 2 inches) by means of the screw jack, permitting the oil to escape through the oil release B103913. Do not remove jack.

(2) Attach pressure gage to oil release (fig. 22).

(3) Force the recoil piston forward, by means of the screw jack, until the gage shows 1,200 to 1,500 pounds per square inch pressure.

INSPECTION INSTRUCTIONS

(4) Reverse the motion of the jack screw, turning no faster than four turns per minute, until the jack head is no longer in contact with the recoil piston. The piston will follow the jack head until the friction developed by the recoil piston and stuffing box packings equals the pressure in the cylinder. Since the oil pressure in the cylinder is greater than that required to overcome the friction until equalized, the gage hand drops without fluctuating, and remains stationary when the piston rod stops moving.

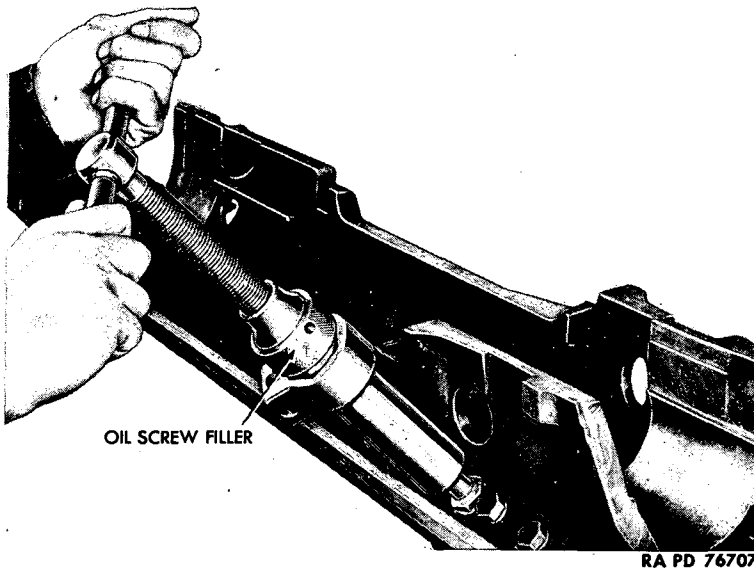

Figure 25—Establishing Oil Reserve

(5) Read the gage. The gage reading at this point represents the sum of the friction of the recoil piston and the friction in the recoil piston rod stuffing box.

(6) Obtain three consecutive uniform gage readings. **NOTE:** Exercise the piston by repeating operations (steps (3), (4), and (5), above) a sufficient number of times until the three consecutive gage readings are practically uniform. This is important since true friction readings cannot be obtained until the packings are well lubricated.

(7) The normal pressure necessary to overcome the combined friction of the recoil piston and piston rod stuffing box is 450 pounds per square inch. This may vary from 350 to 800 pounds per square inch. Recoil mechanisms having excessively low or high friction should be reported to the Chief of Ordnance (par. 24).

(8) Re-establish the oil reserve in the system (TM 9-320) (fig. 25).

**ORDNANCE MAINTENANCE
75-MM HOWITZERS AND CARRIAGES**

Section IV

**TOOLS AND EQUIPMENT FOR MAINTENANCE
AND REPAIR**

14. SPECIAL REPAIR TOOL CHEST.

a. Special repair tools and equipment required for the maintenance and repair of the 75-mm Howitzer materiel are listed in SNL C-18. These tools and equipment are carried in tool chests D5433 and D32123 (figs. 26 and 27):

b. Chest D5433 contains tools and equipment for 75-mm Pack Howitzers M1 and M1A1 and 75-mm Howitzer Carriages M1 and M8. The space occupied by this chest is $1\frac{1}{2}$ cubic feet, the dimensions being: $20\frac{5}{8}$ inches long, $12\frac{5}{8}$ inches wide, and 10 inches high.

c. Chest D32123 contains tools and equipment for 75-mm Howitzers M1 and M1A1 and 75-mm Field Howitzer Carriages M3A1, M3A2, and M3A3. The space occupied by this chest is $2\frac{5}{8}$ cubic feet, the dimensions being: $27\frac{5}{8}$ inches long, $12\frac{5}{8}$ inches wide, and $12\frac{3}{16}$ inches high.

d. **Tool Roll With Contents.** Each chest contains a Tool Roll M4 (figs. 28 and 29) which contains an assortment of tools for general use in work on the materiel. SNL C-18 lists the proper tools to be carried in each of these rolls.

e. Those tools, however, which are of special design and not commonly used, are described and their uses prescribed below. These special tools, like common tools, are listed in SNL C-18.

15. SPECIAL TOOLS.

Bolt, equilibrator locking,
A140673 (fig. 31).

The equilibrator locking or assembly bolt is 22 inches long, threaded $\frac{1}{2}$ -13NC-2 on one end, and knurled on the other end. The purpose of the bolt is to facilitate the assembly of equilibrators of Carriages M3A1, M3A2, and M3A3, and to retain equilibrators as units when making adjustments or when replacing equilibrators (par. 35).

TOOLS AND EQUIPMENT FOR MAINTENANCE AND REPAIR

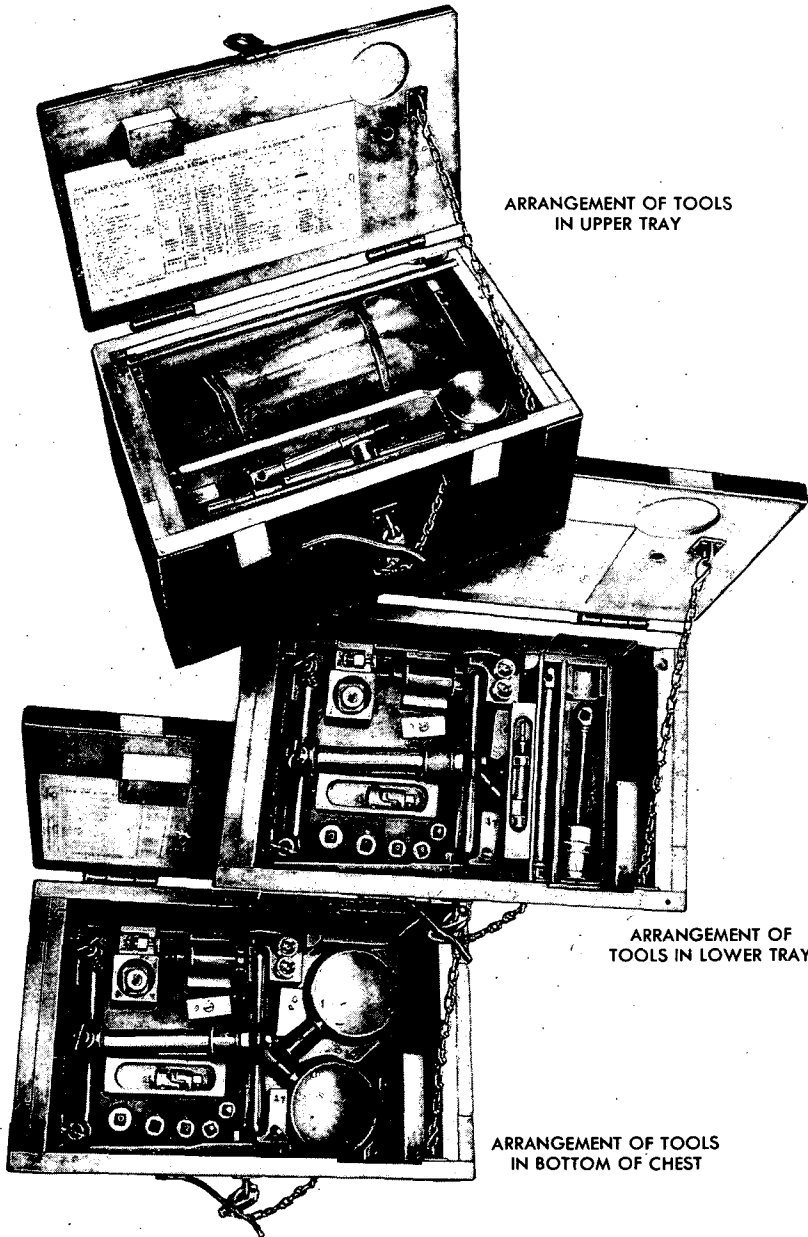

RA PD 76703

Figure 26—Special Repair Tool Chest for 75-mm Pack Howitzers M1 and M1A1 and Carriages M1 and M8

**ORDNANCE MAINTENANCE
75-MM HOWITZERS AND CARRIAGES**

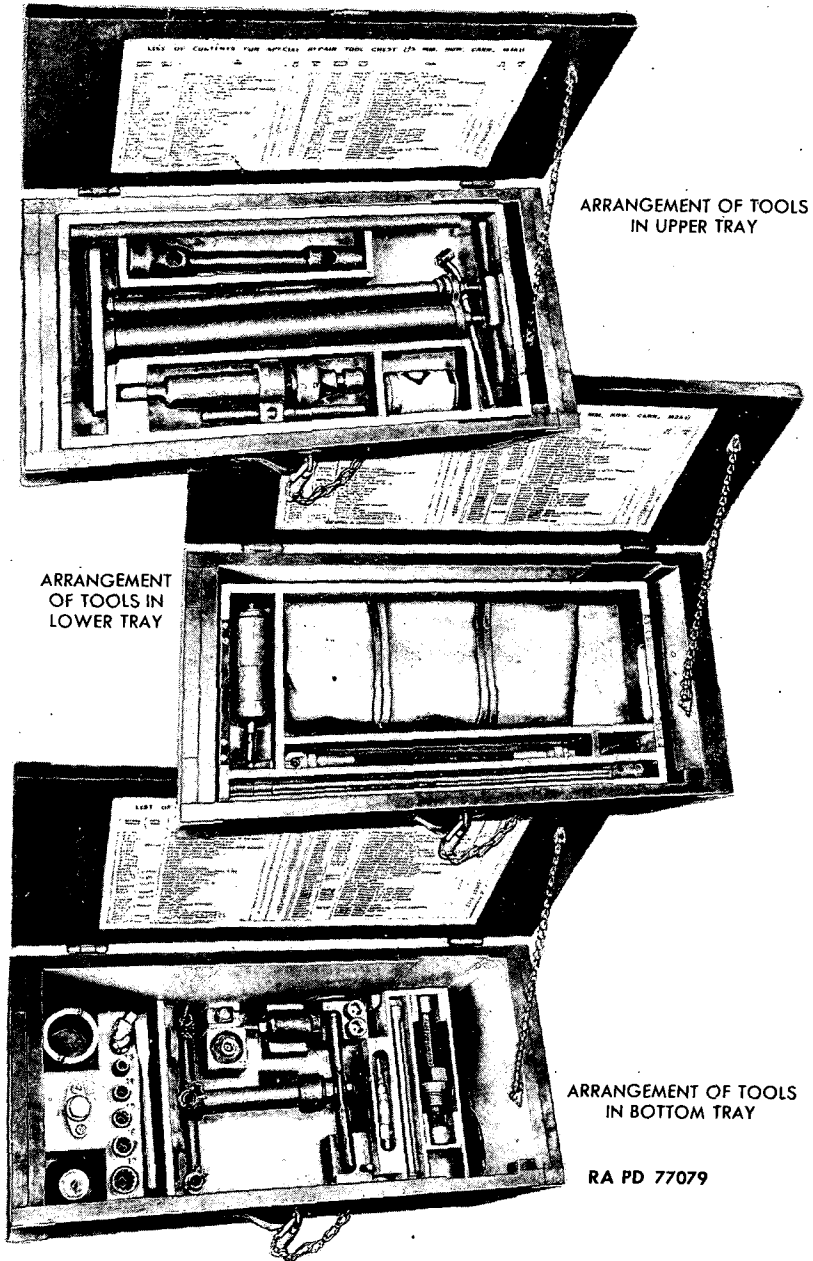
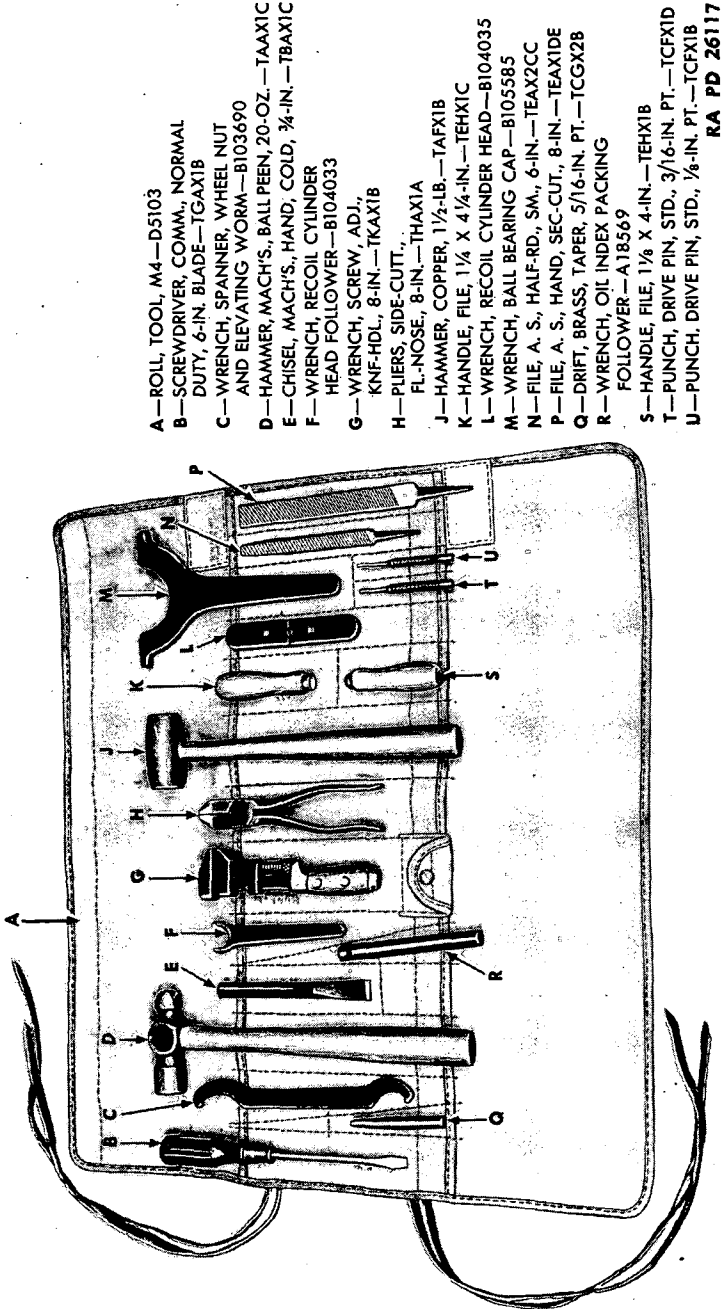

Figure 27—Special Repair Tool Chest for 75-mm Pack Howitzers M1 and M1A1 and Carriages M3A1, M3A2, and M3A3

TOOLS AND EQUIPMENT FOR MAINTENANCE AND REPAIR



- A—ROLL, TOOL, M4—D5103
- B—SCREWDRIVER, COMM., NORMAL DUTY, 6-IN. BLADE—TGAX1B
- C—WRENCH, SPANNER, WHEEL NUT AND ELEVATING WORM—B103690
- D—HAMMER, MACH'S, BALL PEEN, 20-OZ.—TAAX1C
- E—CHISEL, MACH'S, HAND, COLD, 3/4-IN.—TBAX1C
- F—WRENCH, RECOIL CYLINDER HEAD FOLLOWER—B104033
- G—WRENCH, SCREW, ADJ., KNF-HDL, 8-IN.—TKAX1B
- H—PLIERS, SIDE-CUTT., FL-NOSE, 8-IN.—THAX1A
- J—HAMMER, COPPER, 1/2-LB.—TAFX1B
- K—HANDLE, FILE, 1/4 X 4 1/4-IN.—TEHX1C
- L—WRENCH, RECOIL CYLINDER HEAD—B104035
- M—WRENCH, BALL BEARING CAP—B105585
- N—FILE, A. S., HALF-RD, SM., 6-IN.—TEAX2CC
- P—FILE, A. S., HAND, SEC-CUTT., 8-IN.—TEAX1DE
- Q—DRIFT, BRASS, TAPER, 5/16-IN. PT.—TCGX2B
- R—WRENCH, OIL INDEX PACKING FOLLOWER—A18569
- S—HANDLE, FILE, 1/8 X 4-IN.—TEHX1B
- T—PUNCH, DRIVE PIN, STD., 3/16-IN. PT.—TCFX1D
- U—PUNCH, DRIVE PIN, STD., 1/8-IN. PT.—TCFX1B

RA PD 26117

Figure 28—Tool Roll M4 and Contents for 75-mm Pack Howitzers M1 and M1A1 and Carriages M1 and M8

**ORDNANCE MAINTENANCE
75-MM HOWITZERS AND CARRIAGES**

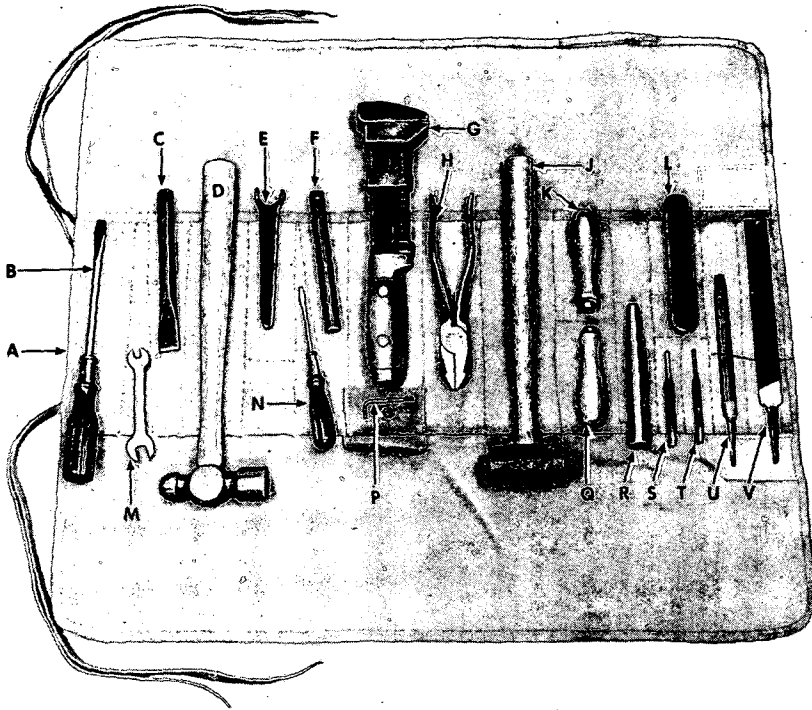

- A—ROLL, TOOL, M4—D5103
- B—SCREWDRIVER, COMM., NORMAL DUTY, 6-IN. BLADE—TGAX1B
- C—CHISEL, MACH'S., HAND, COLD, 3/4-IN.—TBAX1C
- D—HAMMER, MACH'S., BALL PEEN, 20-OZ.—TAAX1C
- E—WRENCH, RECOIL CYLINDER HEAD FOLLOWER—B104033
- F—WRENCH, OIL INDEX FOLLOWER - A18569
- G—WRENCH, SCREW, ADJ., KNF-HDL, 12-IN.—TKAX1C
- H—PLIERS, SIDE-CUTT., FL-NOSE, 8-IN.—THAX1A
- J—HAMMER, COPPER, 1 1/2-LB.—TAFX1B
- K—HANDLE, FILE, 1 1/2 X 4 1/4-IN.—TEHX1C
- L—WRENCH, RECOIL CYLINDER HEAD—B104035
- M—WRENCH, ENGR'S, DBLE-HD., ALLOY-S., 5/16 AND 1/2-IN.—TKKX1C
- N—SCREWDRIVER, COMM., NORMAL DUTY, 3-IN. BLADE—TGAX1A
- P—WRENCH, SOCKET HEAD SET SCREW, 3/32-IN. HEX.—BCTX1G
- Q—HANDLE, FILE, 1 1/8 X 4-IN.—TEHX1B
- R—DRIFT, BRASS, TAPER, 5/16-IN. PT.—TCGX2B
- S—PUNCH, DRIVE PIN, STD., 3/16-IN. PT.—TCFX1D
- T—PUNCH, DRIVE PIN, STD., 1/8-IN. PT.—TCFX1B
- U—FILE, A. S., HALF-RD., SM., 6-IN.—TEAX2CC
- V—FILE, A. S., HAND, SEC-CUT., 8-IN.—TEAX1DE

RA PD 26118

Figure 29—Tool Roll M4 With Contents for 75-mm Pack Howitzers M1 and M1A1 and Carriages M3A1, M3A2, and M3A3

TOOLS AND EQUIPMENT FOR MAINTENANCE AND REPAIR

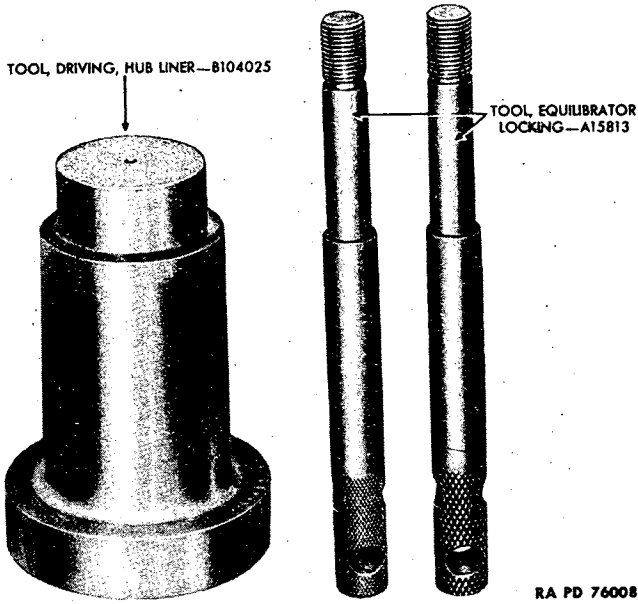

RA PD 76008

Figure 30—Special Repair Tools for 75-mm Howitzer Carriages M1 and M8

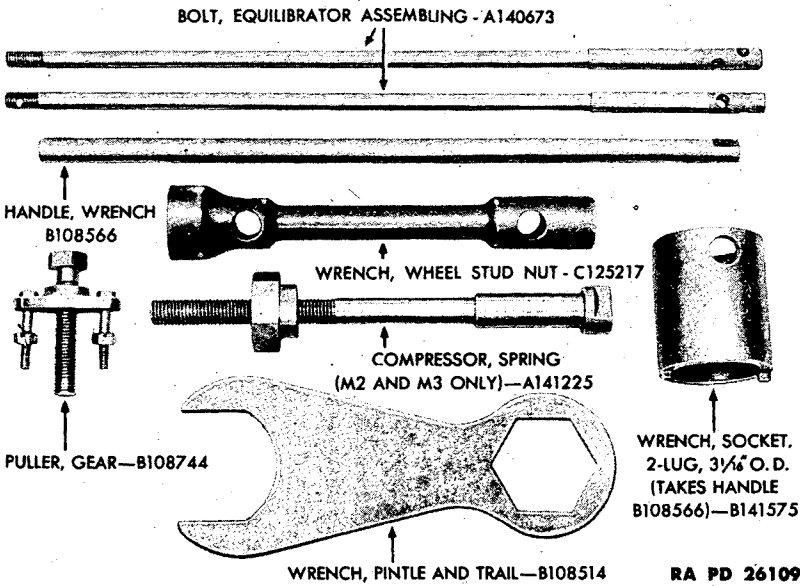

RA PD 26109

Figure 31—Special Repair Tools for 75-mm Howitzer Carriages M3A1, M3A2, M3A3

ORDNANCE MAINTENANCE
75-MM HOWITZERS AND CARRIAGES

RA PD 77080

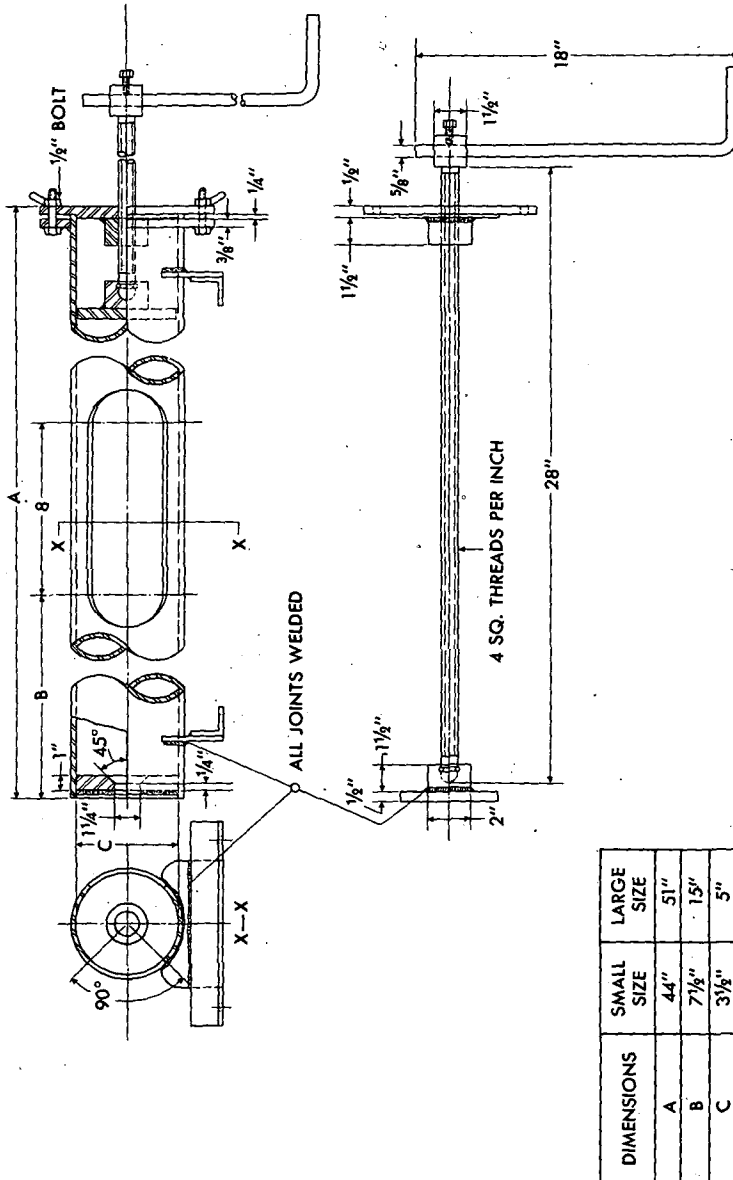
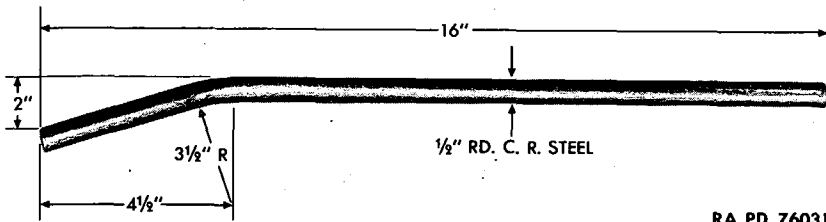

Figure 32—Equibrator Assembling Jig

TOOLS AND EQUIPMENT FOR MAINTENANCE AND REPAIR



RA PD 76031

Figure 33—Improved Driving Bar (Tool)

Compressor, spring, A141225
(for M2 and M3 Carriages
having spring carriers only)
(fig. 31).

The spring compressor is composed of a 3/4-inch threaded bolt, 12 3/4 inches over-all, and a 3/4-inch special nut. The purpose of the spring compressor is to facilitate the assembly and disassembly of the spring carrier group.

Handle, wrench, B108566
(fig. 31).

This handle is used with special wrenches C59566 and B141575.

Puller, gear, B108744
(fig. 31).

The gear puller consists of a plate and three screws, two of which have nuts. It is used to remove the elevating and traversing worm wheels of Carriages M3A1, M3A2, and M3A3 from their shafts (pars. 37 and 39).

Tool, driving, hub liner,
B104025 (fig. 30).

The purpose of this tool is to facilitate the removal of hub liners from the wheel hubs of Pack Howitzer Carriages M1 and M8. It is a bronze casting, cylindrical in shape, and is 4 1/2 inches long.

Tool, equilibrator locking,
A15813 (fig. 30).

This equilibrator locking tool serves the same purpose as equilibrator locking bolt A140673 (fig. 31). The only difference is that it is shorter and is used with Howitzer Carriages M1 and M8.

Wrench, pintle and trail,
B108514 (fig. 31).

This is a special wrench used for removing and tightening pintle pin and trail hinge pin nuts.

Wrench, socket, B141575
(fig. 31).

This special socket wrench is used for removing and replacing ball bearing retainer in elevating mechanisms of M3A1, M3A2, and M3A3 Carriages (par. 39).

**ORDNANCE MAINTENANCE
75-MM HOWITZERS AND CARRIAGES**

16. IMPROVISED TOOLS.

Bar, driving (fig. 33).

This is an improvised driving bar made of 1/2-inch diameter cold rolled steel. It is used when driving trunnion pins from cradle (par. 27).

Jig, equilibrator assembling (fig. 32).

The equilibrator assembling jig is a special fixture used for the disassembly and assembly of the 75-mm howitzer carriage equilibrators. The small size accommodates the M1 and M8 equilibrators; the large size accommodates the M3A1, M3A2, and M3A3 equilibrators.

Section V

MAINTENANCE AND REPAIR INSTRUCTIONS

17. GENERAL.

a. Incidence of wear and breakage make it necessary to completely disassemble various major units of the 75-mm howitzer materiel. Therefore, the following instructions are prescribed to cover the disassembly and assembly of the materiel not covered in TM 9-319 or TM 9-320.

18. ASSEMBLY OF SUBASSEMBLIES.

a. When performing complete carriage and howitzer assembly, all subassemblies must be assembled before attempting to mount them. As a part of all assembly and mounting operations, clean and lubricate the bearings, slide surfaces, threads, etc. All other parts to be assembled must be free from rust and dirt. Rough spots must be smoothed by use of a smooth file, crocus cloth, aluminum-oxide abrasive cloth, or an oilstone. Burs and sharp edges must be removed.

b. Except in emergencies, work requiring welding, riveting, and the making of new parts for major replacements will not be undertaken in the field.

c. Use only wrenches that fit snugly on parts. Tools that do not fit well fail, or cause damage to the corners of nuts, bolt heads, etc.

MAINTENANCE OF HOWITZER

d. Cotter pins must be spread properly after installation. Bolts, screws, and nuts must be tight and safeguarded properly with lock washers or cotter pins. Screws drilled for locking wires must be wired securely.

e. When replacing bushings, remove all burs which may exist in and around the hole. Fit the new bushing to enter a short distance into the hole. Lubricate the exterior of the bushing end and, if possible, place a bolt with washers on both ends through the bushing and the hole. Then draw the bushing into place by tightening the bolt nut. If the bushing is in such a position that the above procedure cannot be followed, place a piece of hardwood against the end of bushing and drive it into place with a hammer. Ream the bushing to the desired fit.

Section VI

MAINTENANCE OF HOWITZER

19. GENERAL.

a. The 75-mm Pack Howitzer M1A1 is the present standard of manufacture. It is used on Carriages M1, M8, M3A1, M3A2, and M3A3. This howitzer is comprised of the tube assembly, breech ring assembly, breechblock assembly, breech operating lever assembly, and Firing Lock M13 assembly. The design facilitates pack and paracrate transportation. The various assemblies may be readily and easily disassembled and assembled.

b. The 75-mm Pack Howitzer M1 is identical with the 75-mm Pack Howitzer M1A1, with the exception of the breech ring assembly and the breechblock assembly. These assemblies are not interchangeable on the two models of howitzers. The differences do not, however, affect disassembly, assembly, and repair.

20. TUBE.

a. General.

(1) The tube assembly is provided with a front eyebolt, lifting eye, and two studs. The lifting eye, together with the front eyebolt, is used as a means of lifting the tube. The lifting eye folds down against the tube when the latter is assembled on the carriage (fig. 34).

(2) **CAUTION:** *In alining the tube and breech ring, use the following procedure, both for reassembly of original tube to breech ring and assembly of a replacement tube.*

ORDNANCE MAINTENANCE
75-MM HOWITZERS AND CARRIAGES

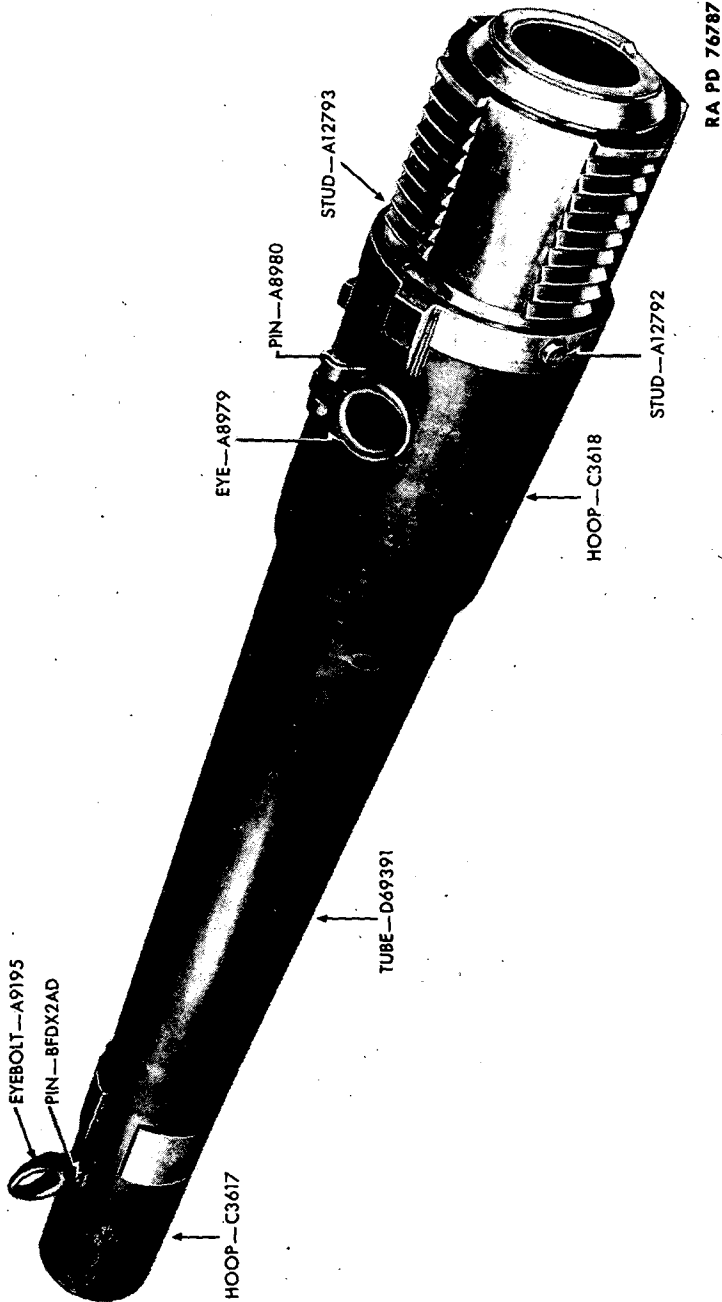

RA PD 76787

Figure 34—Tube Assembly

MAINTENANCE OF HOWITZER

(a) Bring the tube into proper alinement for assembly to the sleigh by applying pressure by hand on the eyebolt.

(b) If the key slots in the muzzle hoops are in the proper position for assembly to the sleigh, note whether the hoop lugs and breech ring stops are in contact. If the stop lugs are in full contact, remove approximately 0.005 inch from each contact face of the breech ring tube stops.

(c) Reassemble the tube to the breech ring. If the stop lugs are in full contact and the tube does not aline properly, repeat the above procedure.

(d) If the stop lugs do not come into full contact, and the tube is not alined properly, disassemble the tube from the breech ring and place a thin coat of dry red lead, grade B, on the chamfered surface of the breech ring. Reassemble the tube, exerting hand pressure, and then disassemble. The red lead deposited on the tube will indicate where interference occurs. File and polish area on tube where lead is deposited with crocus cloth, or oilstone. Repeat this procedure until the tube can be brought into proper alinement by applying only hand pressure to the eyebolt.

(e) Whenever it is difficult to remove a tube from the breech ring, use a strap wrench to turn the tube. Do not use a bar. The use of a strap wrench insures that the eyebolt will not be sheared off in the disassembly of a tight tube.

(3) The studs guide the tube in and out of the breech ring and prevent jamming the threads. Lugs are provided as stops for the tube when it is being assembled to the breech ring.

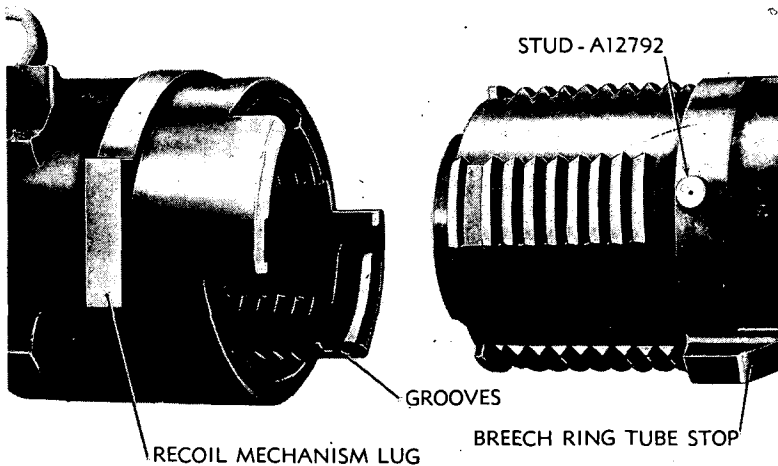

RA PD 26131

Figure 34a—Breech Ring

**ORDNANCE MAINTENANCE
75-MM HOWITZERS AND CARRIAGES**

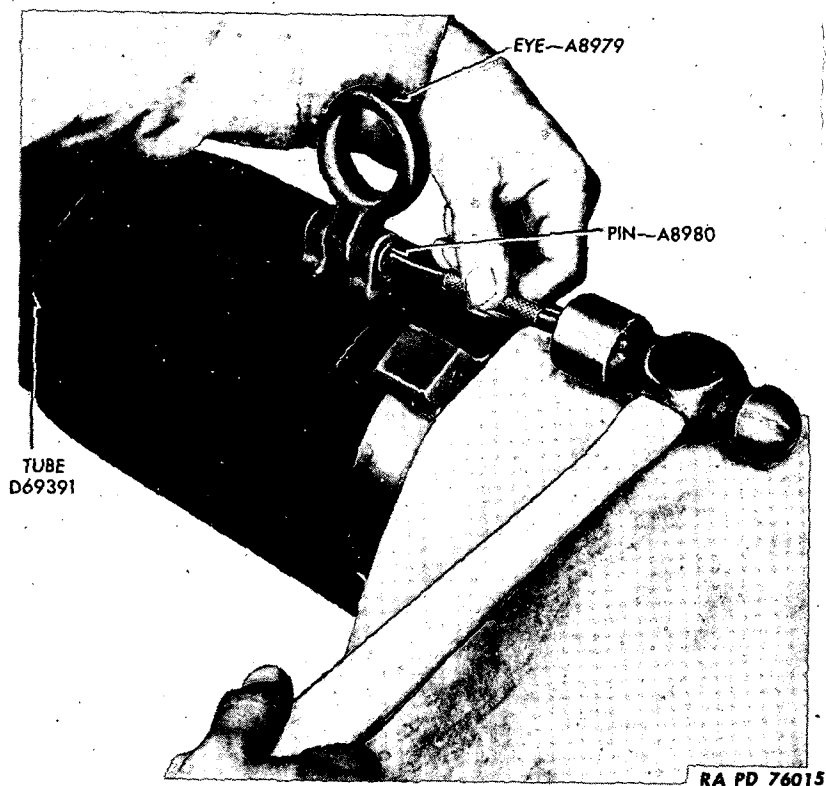

Figure 35—Removing Lifting Eye

(4) Interrupted threads enable rapid assembly and disassembly of the tube and breech ring, one-eighth turn being required.

b. Removal and Disassembly. Removal of the howitzer tube from the carriage is covered in TM 9-319 and TM 9-320. There is no further disassembly of the tube.

c. Repairs.

- (1) Clean tube assembly thoroughly.
- (2) Inspect the tube assembly as outlined in paragraphs 7, 8, 9, 10, and 11.
- (3) **DAMAGED LIFTING EYE.** Remove the damaged lifting eye by driving out the retaining pin (fig. 35). Place new lifting eye in position and secure with pin.

MAINTENANCE OF HOWITZER

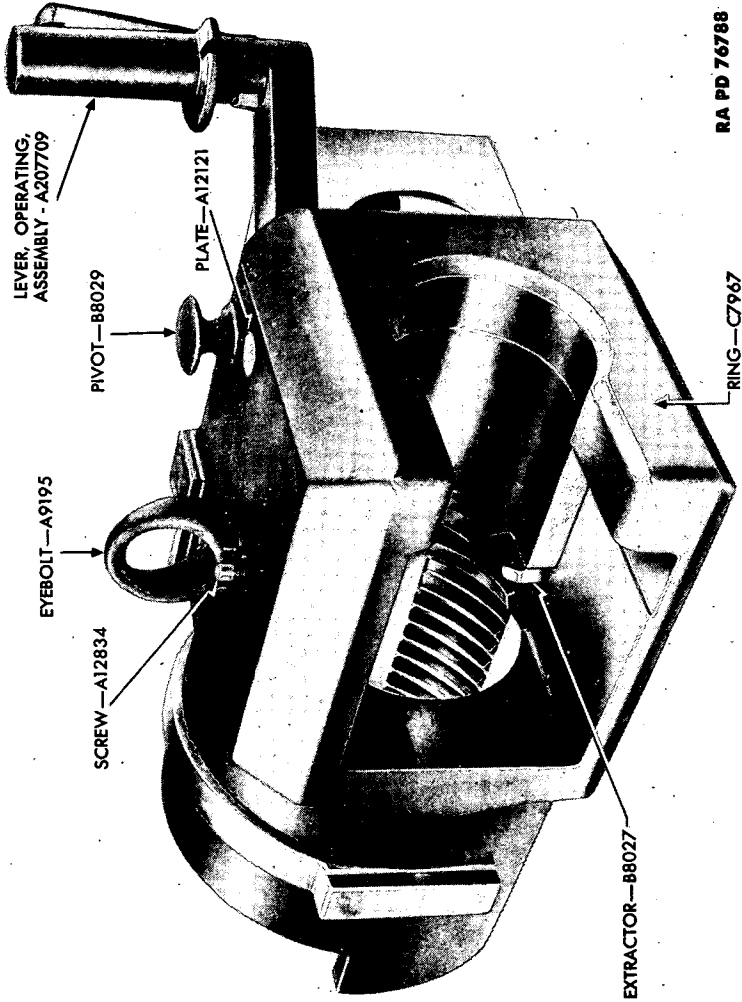

RA PD 76788

Figure 36—Breech Mechanism

**ORDNANCE MAINTENANCE
75-MM HOWITZERS AND CARRIAGES**

(4) **DAMAGED EYEBOLT.** Drive out eyebolt retaining pin and unscrew eyebolt. Screw new eyebolt into place and secure with retaining pin.

(5) **SCORED OR BRUISED THREADS.** Remove scoring or bruises on tube threads with smooth file and polish with crocus cloth. Just enough metal should be removed to restore the original contour of the threads.

(6) **BROKEN OR DAMAGED STUDS.** Replace with a new stud.

d. **Assembly and Installation.** There is no assembly required on the tube. Installation is covered in TM 9-319 and TM 9-320.

21. BREECH MECHANISM.

a. **General.**

(1) The breech mechanism is of the horizontal sliding wedge type, hand operated by means of an operating lever pivoted to the breech ring.

(2) The breech mechanism consists of the breech ring assembly, breechblock assembly, operating lever assembly, trigger assembly, gear cover, trigger shaft, extractor, Firing Lock M13 assembly (fig. 36), and operating lever pivot.

(3) Interrupted threads enable rapid assembly of the breech ring and tube. Two lugs projecting from the front face of the breech ring have cam grooves to guide the tube studs when assembling breech ring to tube. Two lugs, one on each side of the upward cylindrical portion, serve to lock the breech ring to the recoil mechanism.

(4) The leveling plates are inlaid in the top of the breech ring to form seats for the gunner's quadrant.

(5) The trigger is provided with a trigger knob for attaching the lanyard.

(6) Firing Lock M13 assembly is covered in paragraph 22.

b. For description and functioning of the breech mechanism, refer to TM 9-319 and TM 9-320.

c. **Removal and Disassembly.** Removal and disassembly of the breech mechanism are covered in TM 9-319 and TM 9-320.

d. **Repairs.**

(1) Clean all parts of the breech mechanism thoroughly.

(2) Examine all parts carefully for cracks, wear, or breakage.

(3) Examine closely for cutting or abrasions on the pressure side of breechblock and breech recess in breech ring. Remove cutting or abrasions as prescribed in paragraph 20 c (5).

MAINTENANCE OF HOWITZER

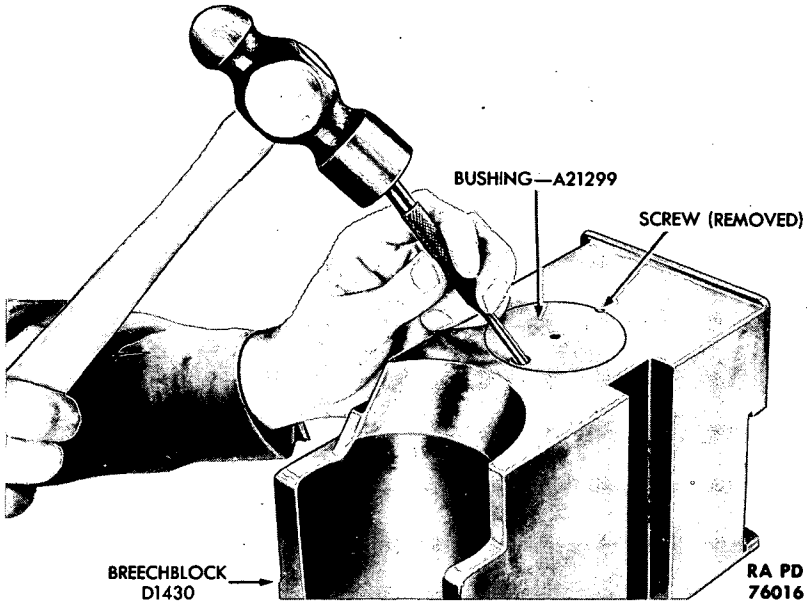

Figure 37—Removing Breechblock Bushing

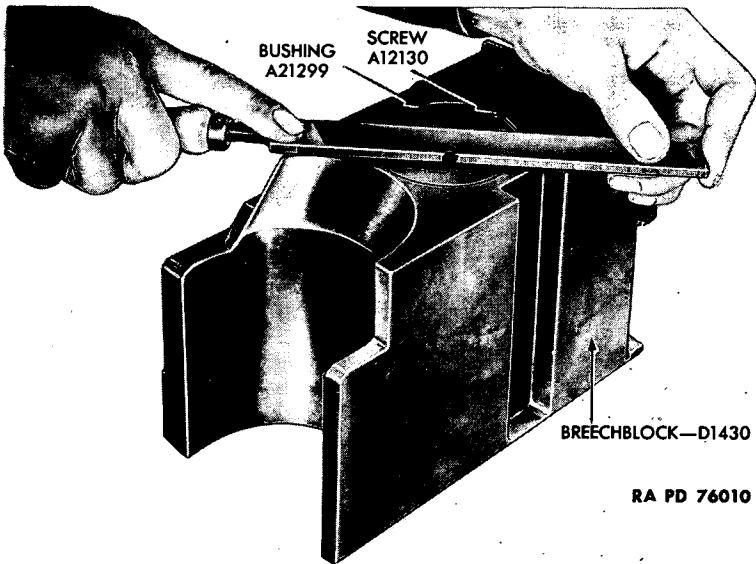

Figure 38—Filing Breechblock Bushing

**ORDNANCE MAINTENANCE
75-MM HOWITZERS AND CARRIAGES**

- (4) Repair other burred or scored parts in same manner as above.
- (5) Replace worn or damaged parts.
- (6) **REPLACE WORN BREECHBLOCK BUSHING** (figs. 37 and 38).
 - (a) A worn firing pin hole in the breechblock bushing may cause fouling of the firing pin. Replace bushing when in worn condition.
 - (b) Remove the screw from breechblock and bushing. If bushing is too tight to unscrew from breechblock, drill a hole in face of bushing large enough to insert a $\frac{3}{8}$ -inch drift. Unscrew bushing by tapping drift with a hammer.
 - (c) Install new bushing. Then saw or mill bushing head flush with top surface of breechblock. Drill and tap a hole (half in bushing and half in breechblock) for a 0.190-32NF-3 x 0.40 screw.
 - (d) File and polish the bushing face smooth with the breechblock face. Then install the screw.
- (7) **DAMAGED LEVELING PLATES** (figs. 39 and 40). Damaged leveling plates are repaired by filing and scraping in the following manner:
 - (a) With the howitzer tube approximately level, place a master level rest or parallel straightedge in muzzle end of tube on lower side of bore (fig. 39).

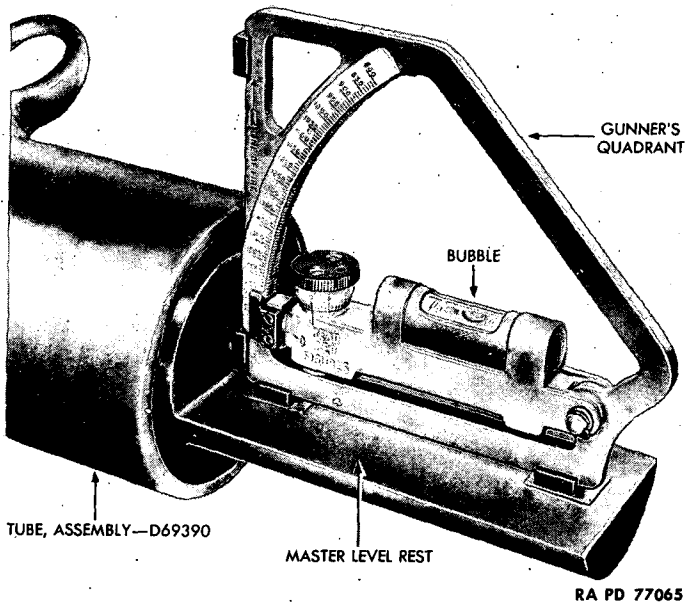
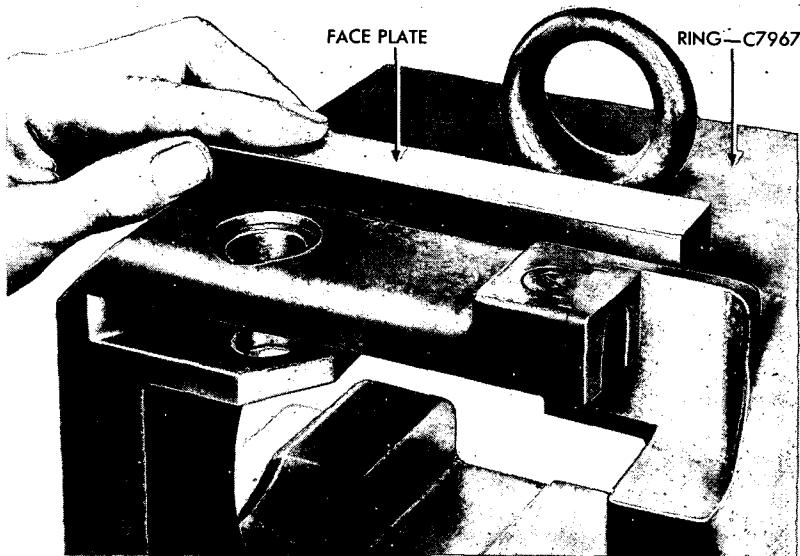

Figure 39—Checking Bore Alinement With Leveling Plates

MAINTENANCE OF HOWITZER



RA PD 76719

Figure 40—Checking Surface of Leveling Plates for High Spots

(b) Place master level or gunner's quadrant on the protruding end of the master level rest or parallel straightedge and bring the howitzer exactly level.

(c) Transfer the master level or gunner's quadrant to the leveling plates and remove metal by filing and polishing from the leveling plate toward which the bubble moves, until bubble is exactly centered.

(d) A flat, true surface or face plate large enough to cover both leveling plates (fig. 40), coated with prussian blue, should be used to detect high spots and to insure that entire surface of each leveling plate is true, one with the other.

(8) **DAMAGED EYEBOLT.** Remove eyebolt retaining screw, then unscrew and remove the damaged eyebolt. Screw new eyebolt in tight and secure with set screw (fig. 41).

e. **Assembly and Installation.** Assembly and installation of the breech mechanism are covered in TM 9-319 and TM 9-320.

22. FIRING LOCK M13.

a. General.

(1) The Firing Lock is designed to deliver a quick flow of sufficient force to fire the primer. Anything which interferes with this quick movement is cause for malfunction, and maintenance and repair are required.

ORDNANCE MAINTENANCE
75-MM HOWITZERS AND CARRIAGES

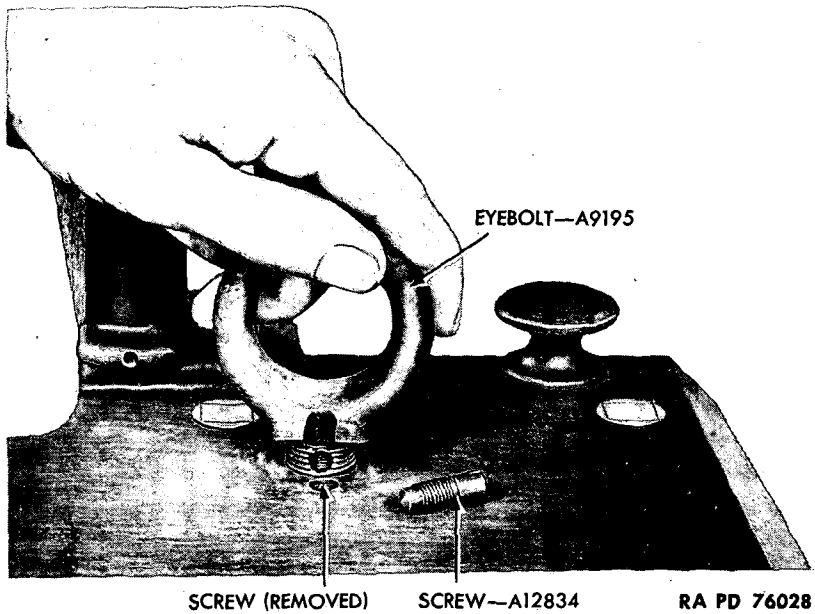

Figure 41—Removing Eyebolt

(2) A complete description of the functioning of the Firing Lock M13 is contained in TM 9-319 and TM 9-320.

b. **Removal and Disassembly.** Removal and disassembly of the Firing Lock M13 are covered in TM 9-319 and TM 9-320.

c. **Repairs.**

(1) Remove burrs and smooth roughened surfaces with crocus cloth or oilstone.

(2) Replace worn, damaged, or deformed parts.

d. **Assembly and Installation.** Assembly and installation of Firing Lock M13 are covered in TM 9-319 and TM 9-320.

Section VII

**MAINTENANCE OF RECOIL MECHANISM
INCLUDING BOTTOM SLEIGH**

23. GENERAL.

a. Disassembly, repair, and assembly of a recoil mechanism of this type can be undertaken only at a repair shop especially equipped for the purpose. High pressures present in the system at all times make it extremely dangerous to attempt unauthorized disassembly.

MAINTENANCE OF RECOIL MECHANISM INCLUDING
BOTTOM SLEIGH

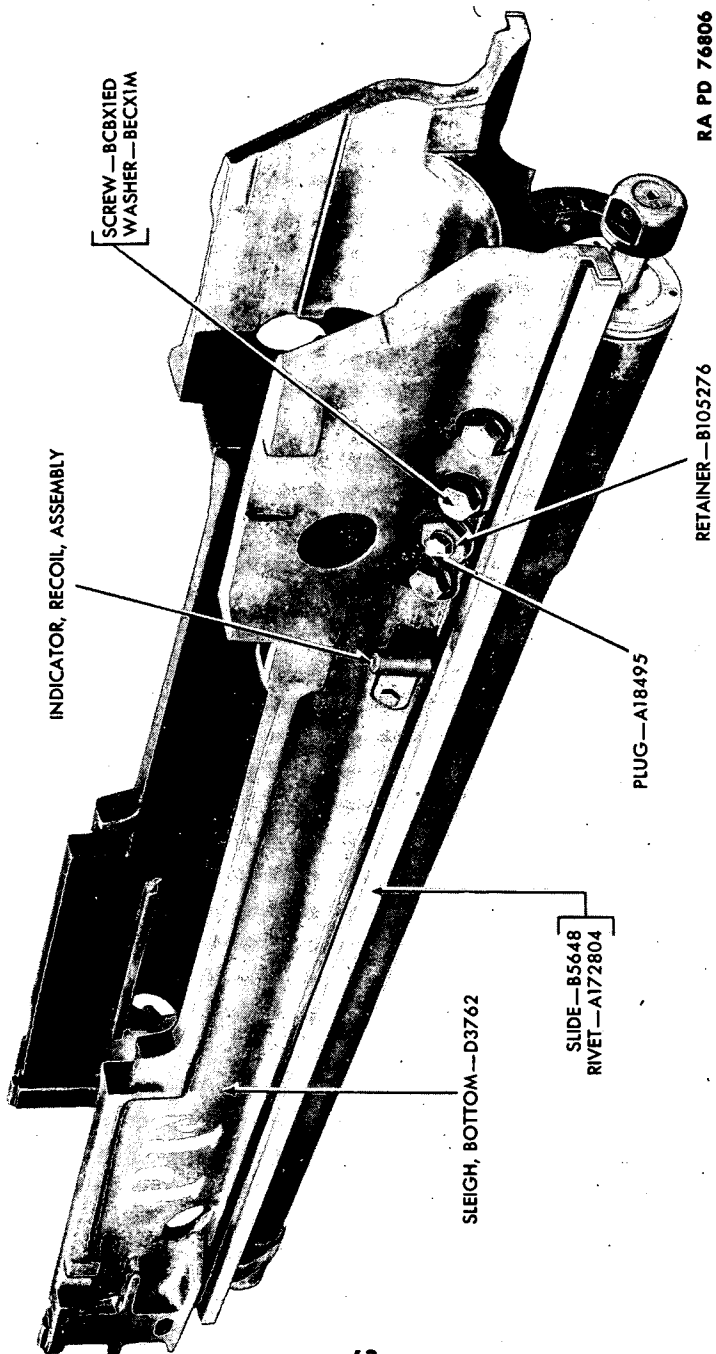

Figure 42—Bottom Sleigh and Recoil Mechanism

**ORDNANCE MAINTENANCE
75-MM HOWITZERS AND CARRIAGES**

It is forbidden to perform disassembly of the recoil mechanism beyond that outlined in this manual.

b. All work on the recoil mechanism must be performed by Ordnance maintenance personnel under the direction of an officer especially designated for this purpose.

c. Complete inspection procedure is contained in paragraphs 12 and 13 of this manual.

24. RECOIL MECHANISM AND BOTTOM SLEIGH.**a. General.**

(1) The recoil mechanism which is used on the 75-mm howitzer materiel is of the hydropneumatic, constant, floating piston type, designated Recoil Mechanism M1A4.

(2) The two cylinders, known respectively as the recoil cylinder and the recuperator cylinder, are fixed underneath the bottom sleigh and are screwed into the yoke (fig. 42).

(3) The piston rod is secured to the cradle by means of the piston rod latch. The yoke and cylinder move with the bottom sleigh and howitzer in recoil and counterrecoil, while the piston remains stationary.

(4) The recuperator cylinder front head is fitted with an oil index. The function of the oil index is to show the amount of reserve oil in the mechanism.

(5) The recoil cylinder filling and drain valve is contained in the recoil cylinder filling valve housing located near the right front of the bottom sleigh.

(6) The recoil cylinder is closed at the rear by the respirator. As this respirator is on the low-pressure side of the piston, elaborate packing is not required.

(7) A recoil indicator of the spring-controlled, plunger type is bolted to the right side of the bottom sleigh near the front (fig. 42).

(8) On each side of the bottom sleigh there are strips or slides which engage the slideways or guides of the cradle to guide the bottom sleigh to recoil and counterrecoil (fig. 42).

b. Removal and Disassembly.

(1) Removal of recoil mechanism from carriage is covered in TM 9-319 and TM 9-320.

(2) All parts of this mechanism which are allowed to be disassembled, repaired, and reassembled are covered in the subparagraphs immediately following:

**MAINTENANCE OF RECOIL MECHANISM INCLUDING
BOTTOM SLEIGH**

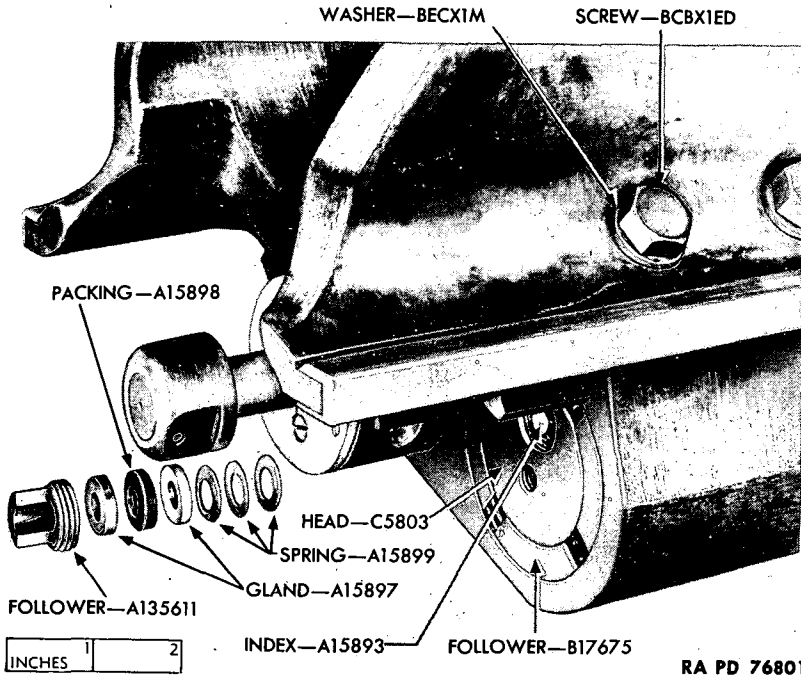

Figure 43—Oil Index—Exploded View

c. Repairs.

- (1) Clean recoil mechanism and sleigh thoroughly.
- (2) Inspect the recoil mechanism as outlined in paragraphs 12 and 13.
- (3) Oil index projects less than the required distance, due to loss of reserve oil.
- (4) Oil index remains stationary when reserve is pumped in against evident pressure. This is due to packing being too tight, or index broken or locked by some foreign substance.
- (5) **OIL INDEX STICKING.**
 - (a) Drain off the reserve oil (par. 12 h).
 - (b) Insert approximately five complete turns of the oil screw fillers. Tap oil index lightly as oil is being added.
 - (c) If oil index still fails to function, remove the oil index follower (fig. 43), then pump more oil into the system with oil screw filler to force the packing and springs from the packing recess.

**ORDNANCE MAINTENANCE
75-MM HOWITZERS AND CARRIAGES**

(d) Install new packing and reassemble, making certain that the convex side of the last spring removed (first to be replaced) faces outward, and that the convex surface of the middle spring is toward the convex surface of the spring just inserted, and that the convex surface of the third spring is toward the outside, and next to flat surface of gland which follows. The concave surfaces of the glands face the packing. Tighten the oil index packing follower until the Belleville springs are compressed metal-to-metal, then back off on the follower approximately one-eighth turn. This will cause the Belleville springs to exert the full pressure on the packing.

(e) If oil index still sticks, report the condition with full details to the Chief of Ordnance.

(6) **HOWITZER RETURNS TO BATTERY WITH TOO GREAT A SHOCK.** This is an indication of too much reserve oil.

(7) **HOWITZER FAILS TO RETURN TO BATTERY, CAUSED BY ONE OR MORE OF THE FOLLOWING:**

- (a) Insufficient oil reserve or air in the mechanism.
- (b) Low nitrogen pressure.
- (c) Excessive friction of slides.
- (d) Damaged piston rod or piston.
- (e) Leakage of oil past recoil piston.

(8) **HOWITZER SLOW TO RETURN TO BATTERY WHEN OIL INDICATION IS NORMAL.** This is due to insufficient nitrogen pressure.

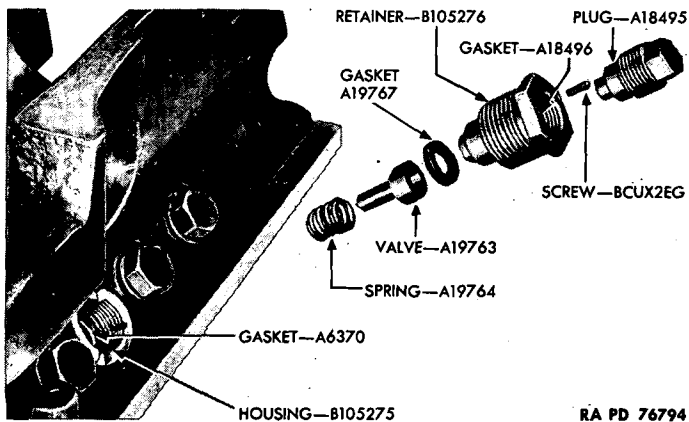

RA PD 76794

Figure 44—Filling Valve—Exploded View

MAINTENANCE OF RECOIL MECHANISM INCLUDING BOTTOM SLEIGH

(9) Uneven and jerky counterrecoil is caused by lack of lubrication or scoring of sliding surfaces, or air in the mechanism.

(10) **FILLING VALVE FAILURE.** Filling valve failure is indicated by unusual oil leakage into the filling and drain plug recess. Correct with following procedure:

(a) Remove filling and drain plug (fig. 44).

(b) Remove small set screw from filling plug retainer, then unscrew and remove the retainer.

(c) Remove gasket A19767, filling valve, and valve spring (fig. 44). If examination shows gasket to be unserviceable, replace with new one and reassemble valve.

(11) If howitzer does not recoil full distance it is due to high viscosity of oil caused by low temperature or scoring of sliding surfaces.

(12) **EXCESSIVE OIL LEAKAGE FROM FILLING AND DRAIN VALVE, CAUSED BY STICKING VALVE OR DEFECTIVE PACKING.** Howitzer recoils too far. This is due to air in the mechanism.

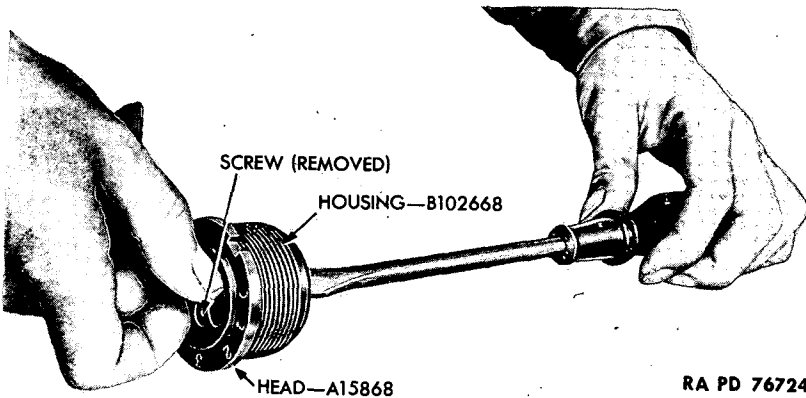

RA PD 76724

Figure 45—Disassembling Respirator

(13) **FAULTY RESPIRATOR.**

(a) Remove recoil cylinder rear head (respirator assembly), using special wrench provided for this purpose (fig. 23).

(b) Then loosen and remove special set screw A15925 from respirator adjusting head (fig. 45). Holding screwdriver in slot in rear face of the respirator valve, unscrew respirator adjusting head. **CAUTION:** Be careful when unscrewing adjusting head, as the ball CCAX1AA and spring A15861 (fig. 46) will have a tendency to fly out.

**ORDNANCE MAINTENANCE
75-MM HOWITZERS AND CARRIAGES**

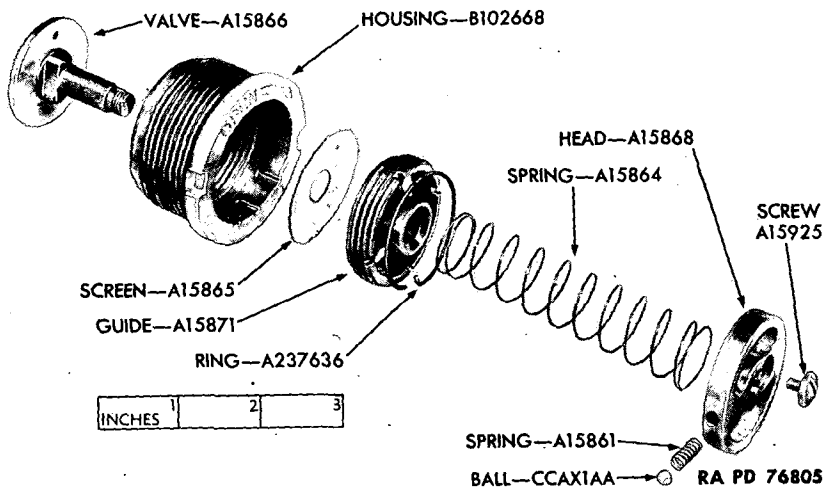

Figure 46—Respirator—Exploded View

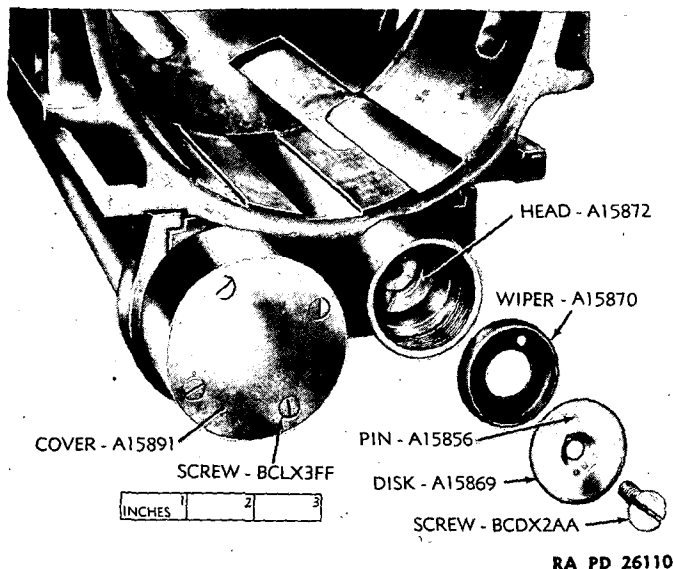

Figure 47—Recoil Cylinder Wiper—Exploded View

- (c) Remove the respirator valve, coil spring, and snap ring. Then unscrew the valve guide and screen.
- (d) Clean all of the parts thoroughly.
- (e) Replace all worn or damaged parts with new parts, then reassemble.

**MAINTENANCE OF RECOIL MECHANISM INCLUDING
BOTTOM SLEIGH**

(14) **ADJUSTING RECOIL PISTON PACKING.** Leakage of oil past the recoil piston frequently can be corrected by tightening the recoil piston head as in the following steps:

- (a) Remove recoil cylinder rear head (fig. 23).
- (b) Remove cap screw from recoil piston disk and piston head. Then remove recoil piston disk and recoil cylinder wiper (fig. 47).
- (c) Tighten up on the recoil piston head. This will compress the packing to stop leakage. *CAUTION: Do not tighten too tight—not over one-quarter turn of the recoil piston head.*
- (d) Replace worn or damaged disk and wiper, then reassemble.

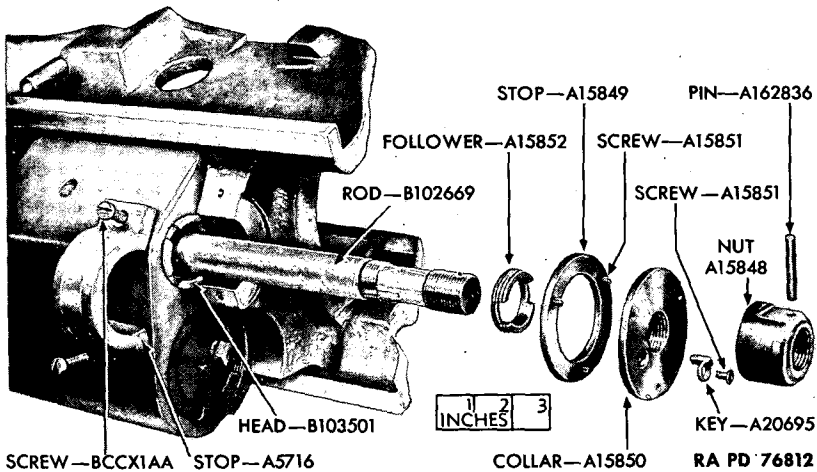

Figure 48—Piston Rod Stop and Collar—Exploded View

(15) **ADJUSTMENT OF RECOIL CYLINDER FRONT AND HEAD FOLLOWER.** In some instances, recoil mechanisms having excessively low recoil piston and recoil piston rod stuffing box frictions can be corrected as follows:

(a) If the friction is low, adjustment can be made by tightening up slightly (not to exceed one-tenth of a turn) on recoil cylinder head follower and recoil stuffing box head. Low friction, however, is usually due to worn or loose packing in the piston.

(b) Excessive oil leakage may usually be corrected in the same manner.

(16) **DAMAGED SLEIGH SLIDES.**

- (a) Clean the slides thoroughly.

ORDNANCE MAINTENANCE
75-MM HOWITZERS AND CARRIAGES

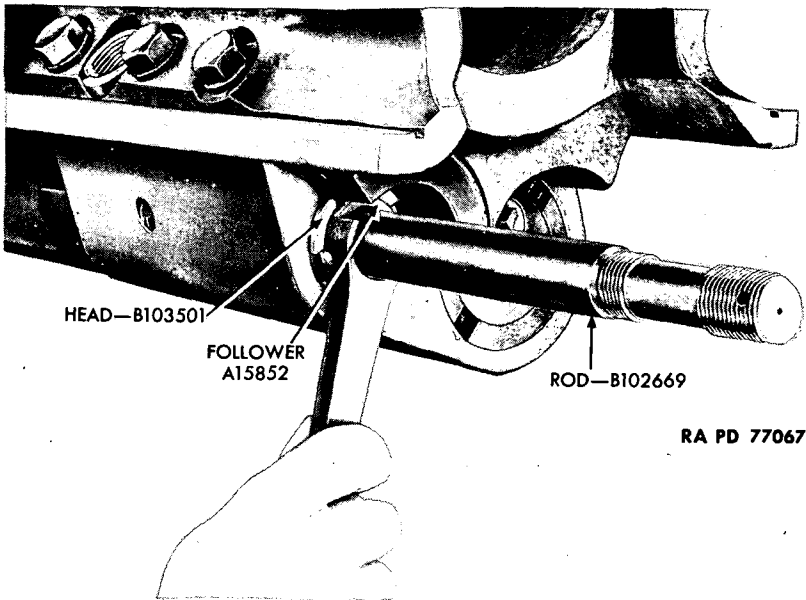

RA PD 77067

Figure 49—Adjusting Recoil Cylinder Head Follower

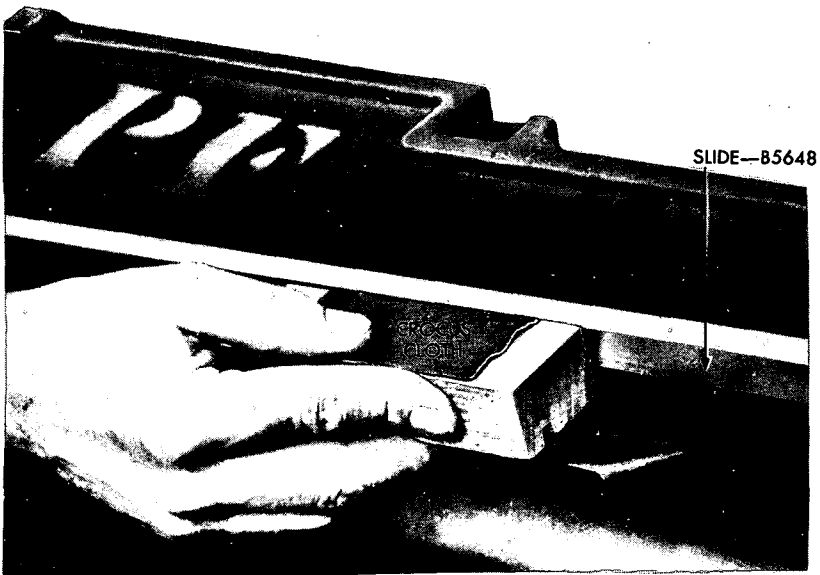

RA PD 76009

Figure 50—Removing Bur From Sleigh Slide

MAINTENANCE OF RECOIL MECHANISM INCLUDING BOTTOM SLEIGH

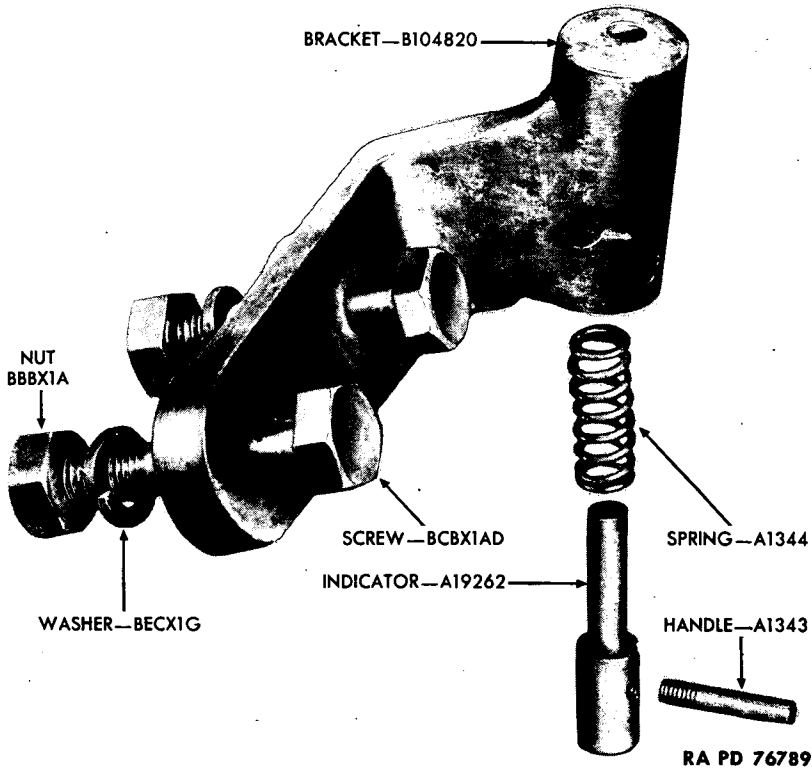

Figure 51—Recoil Indicator—Exploded View

(b) Remove scores or bruises from slides with a flat scraper or smooth file. Remove only enough metal to level the surface. Polish with crocus cloth (fig. 50).

(c) Always clean the slides after scraping and polishing. Otherwise, small particles of metal will act as an abrasive when howitzer is in operation.

(d) Report badly damaged slides to Chief of Ordnance.

(17) BROKEN OR DAMAGED RECOIL INDICATOR (fig. 51).

(a) Loosen and remove screws, washers, and nuts which secure recoil indicator assembly to sleigh, and remove assembly.

(b) Unscrew indicator handle from indicator. Indicator and spring will then drop out of recoil indicator bracket.

(c) Clean all parts thoroughly. Replace all worn or damaged parts and reassemble.

d. **Assembly and Installation.** Assembly and installation of recoil mechanism are covered in TM 9-319 and TM 9-320.

ORDNANCE MAINTENANCE
75-MM HOWITZERS AND CARRIAGES

Section VIII

MAINTENANCE OF PACK HOWITZER CARRIAGES
M1 AND M8

25. GENERAL.

a. The 75-mm Pack Howitzer Carriage M1 is the standard for mule pack artillery, and the 75-mm Pack Howitzer Carriage M8 is the standard for parachute pack and airborne artillery. The 75-mm Pack Howitzer Carriage M8 is also truck-drawn. These two carriages are identical with the exception of the wheels and tires (par. 2).

b. The design is for traverse on the axle. To compensate for the unbalanced weight about the trunnions, spring equilibrators are mounted within the front trails. The primary groups are the top sleigh, bottom sleigh including recoil mechanism, cradle, traversing mechanism and axle, elevating mechanism, front and rear trails, and the wheels. The trails are of the modified box type.

26. TOP SLEIGH.

a. General.

(1) The top sleigh retains the howitzer in the bottom sleigh and forms a covering for it.

(2) The top sleigh is composed of the top sleigh body, top sleigh clamping cam, clamping latch, clamping latch pin, cam bushing, and a thong for retaining the latch pin.

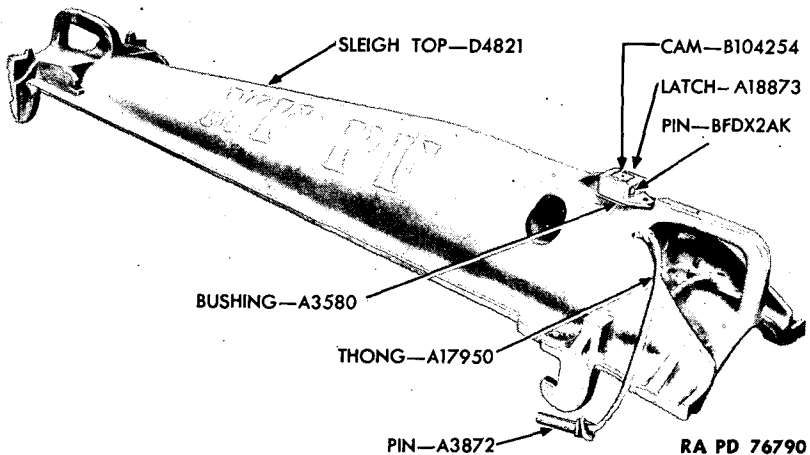

Figure 52—Top Sleigh Assembly

MAINTENANCE OF PACK HOWITZER CARRIAGES M1 AND M8

(3) The cam, hand operated by means of the socket of the handspike, when turned to the locked position, forces the top sleigh forward. By inserting the top sleigh clamping latch pin, the top and bottom sleighs are locked together and retained in position.

b. Removal and Disassembly.

(1) Removal of top sleigh assembly from carriage is covered in TM 9-319 and TM 9-320.

(2) There is no other disassembly required except for replacement of worn or damaged parts as covered in subparagraph c, below.

c. Repairs.

(1) Clean the top sleigh thoroughly.

(2) Examine all parts carefully for cracks, wear, or breakage.

(3) Examine locking lugs and other bottom sleigh mating surfaces for burs or bruises. Remove burs and bruises with a smooth file and polish with crocus cloth (fig. 53).

(4) Replace worn or damaged parts.

(5) REPLACE WORN CLAMPING LATCH BUSHING.

(a) Drive straight pin out of clamping latch and clamping latch pin (fig. 54). The clamping latch will drop down and out. If not, tap cam lightly with brass drift and hammer.

(b) Turn top sleigh over and support it on two wood blocks, high enough that cam bushing can be driven out (fig. 55). Drive bushing out with 1-inch diameter x 6-inch brass bar and hammer.

(c) Clean out bushing hole in top sleigh. Coat outside surface of new bushing with the prescribed lubricant and drive it into place in the top sleigh, using a wood block and hammer. Ream bushing to size 0.875 — 0.002 inch. Cam shaft diameter is 0.873 inch.

(d) Rotate cam as it is being inserted. Make sure it rotates free and easy without side play (fig. 56). Install cam and replace clamping latch and pin.

d. **Assembly and Installation.** Assembly and installation of top sleigh assembly is covered in TM 9-319 and TM 9-320.

27. CRADLE.

a. General.

(1) The cradle is a trough-shaped piece with guides along its entire length to embrace the slides of the bottom sleigh. The cradle is closed at the front end except for openings necessary for the latching of the recoil piston rod and for inspection of the oil index.

**ORDNANCE MAINTENANCE
75-MM HOWITZERS AND CARRIAGES**

SLEIGH—D3762

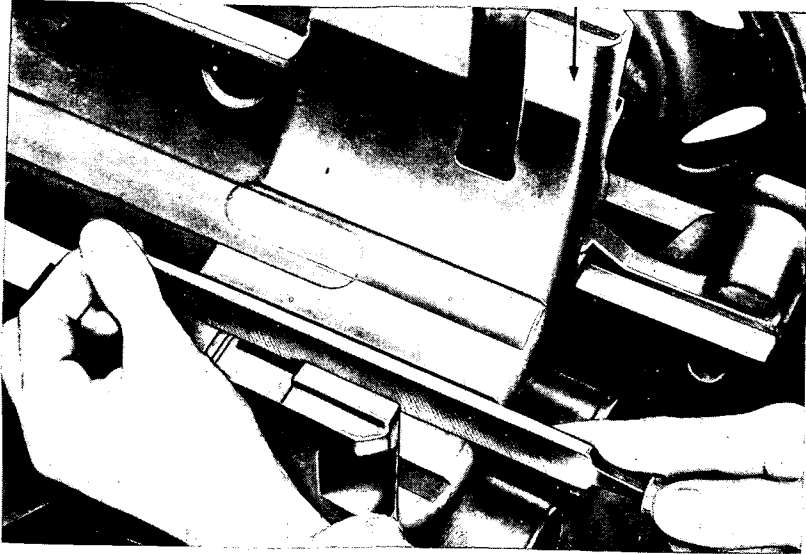

RA PD 77073

Figure 53—Removing Burs From Bottom Sleight

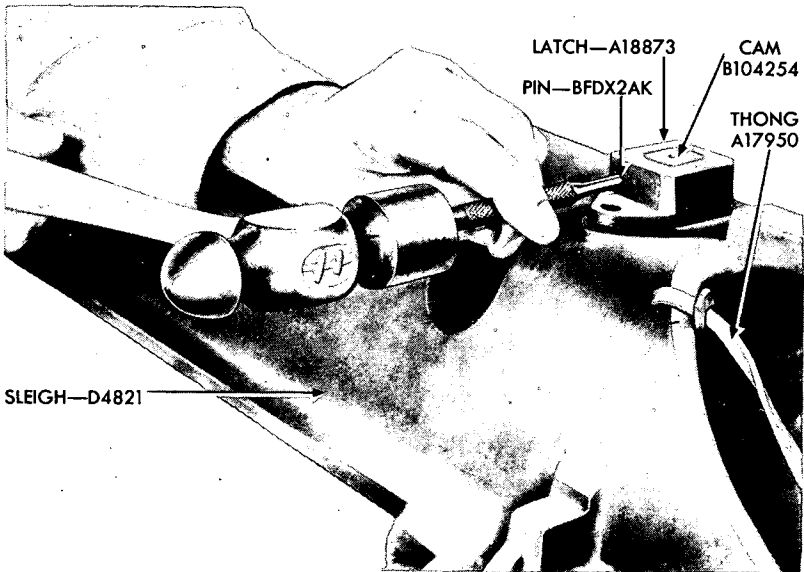

RA PD 76026

Figure 54—Removing Top Sleight Clamping Latch

MAINTENANCE OF PACK HOWITZER CARRIAGES M1 AND M8

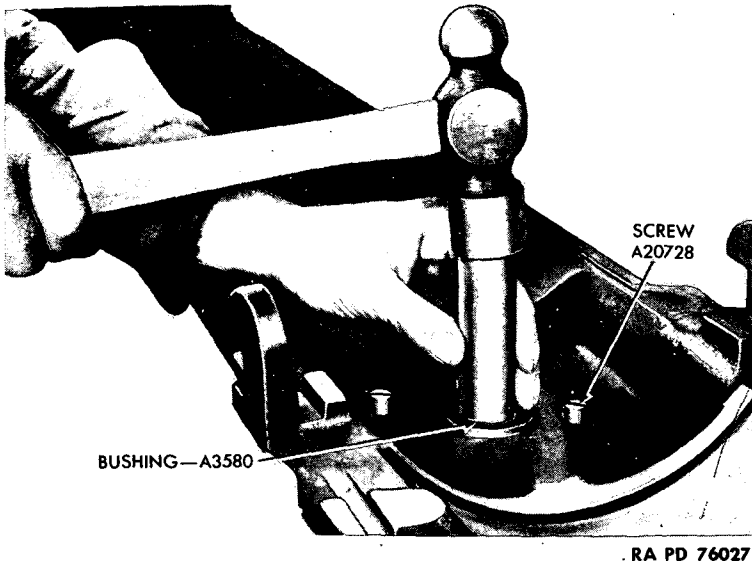

RA PD 76027

Figure 55—Removing Top Sleigh Clamping Cam Bushing

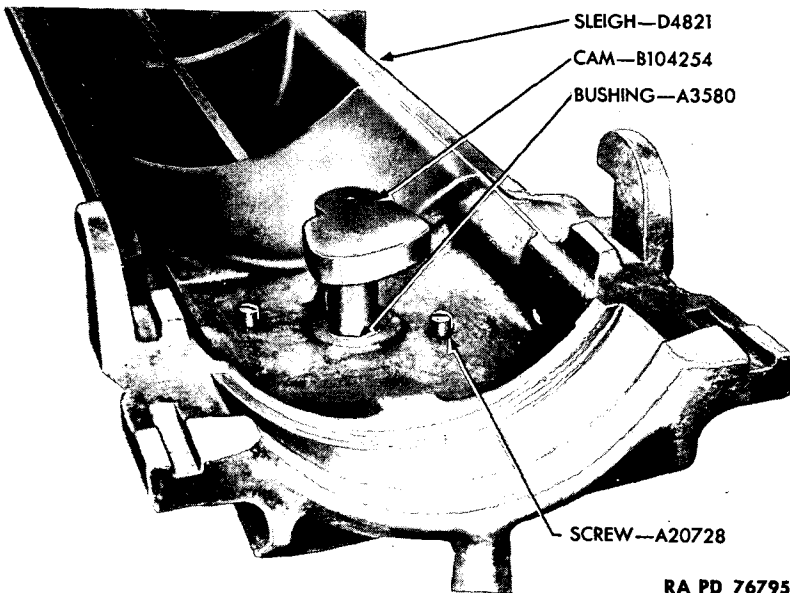

RA PD 76795

Figure 56—Installing Top Sleigh Clamping Cam

**ORDNANCE MAINTENANCE
75-MM HOWITZERS AND CARRIAGES**

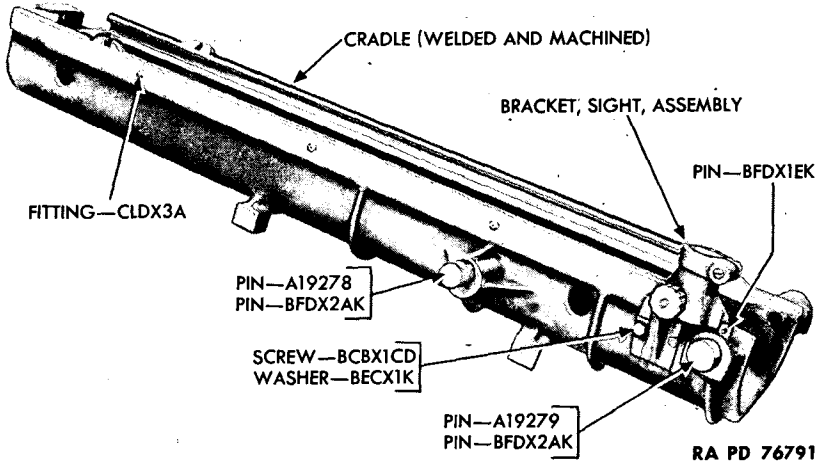

Figure 57—M1 and M8 Cradle Assembly

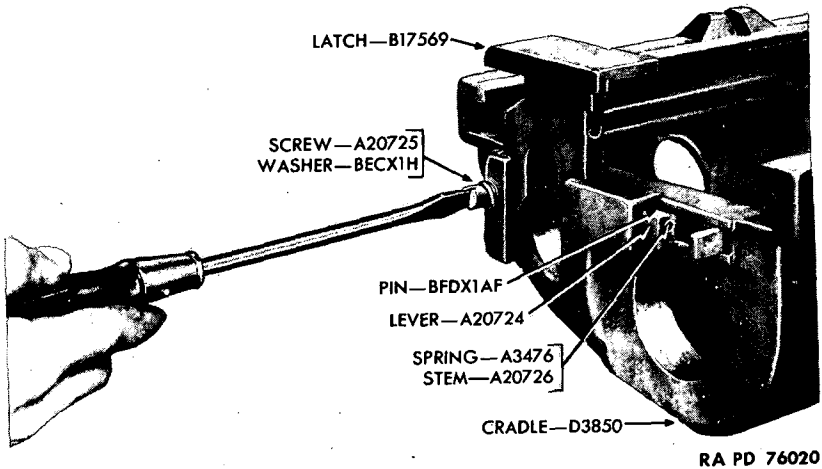

Figure 58—Removing Piston Rod Latch

(2) The piston rod latch slides vertically in grooves in the front end of the cradle and drops down behind the piston rod nut to secure the piston rod to the cradle.

(3) With the bottom sleigh and howitzer in the cradle, the latch cannot be disengaged, as interference with the howitzer tube prevents the latch from rising.

MAINTENANCE OF PACK HOWITZER CARRIAGES M1 AND M8

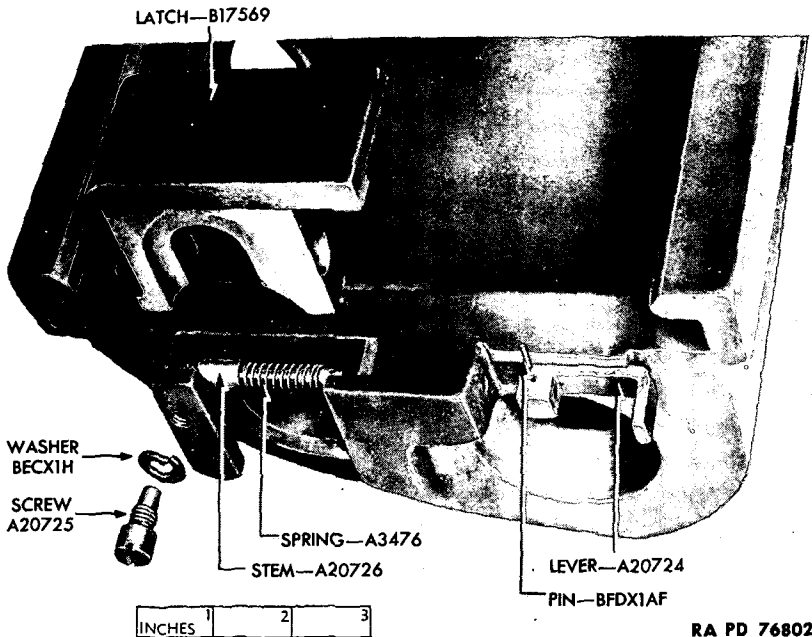

Figure 59—Piston Rod Latch and Lever—Exploded View

(4) Near the rear end of the cradle are four locking pins which, when engaged with notched bearings on the rockers, lock the cradle firmly to the rockers.

(5) The sight bracket is attached to the left rear side of the cradle. The sight bracket is fitted with a sight retaining shaft that automatically returns to the locked position. A spring-controlled plunger is provided to hold a lug of the telescope mount against a headless screw. The screw may be adjusted by means of the nut on the screw. Accuracy of alinement of the sight in azimuth is thereby maintained, and quick removal of the telescope mount is provided.

b. Removal and Disassembly.

(1) Removal of cradle from the carriage is covered in TM 9-319 and TM 9-320.

(2) **DISASSEMBLY OF PISTON ROD LATCH AND LEVER** (figs. 58 and 59).

(a) Remove piston rod latch screw and washer.

(b) Pull piston rod latch lever out of engagement with piston rod latch. Lift piston rod latch up out of cradle.

ORDNANCE MAINTENANCE
75-MM HOWITZERS AND CARRIAGES

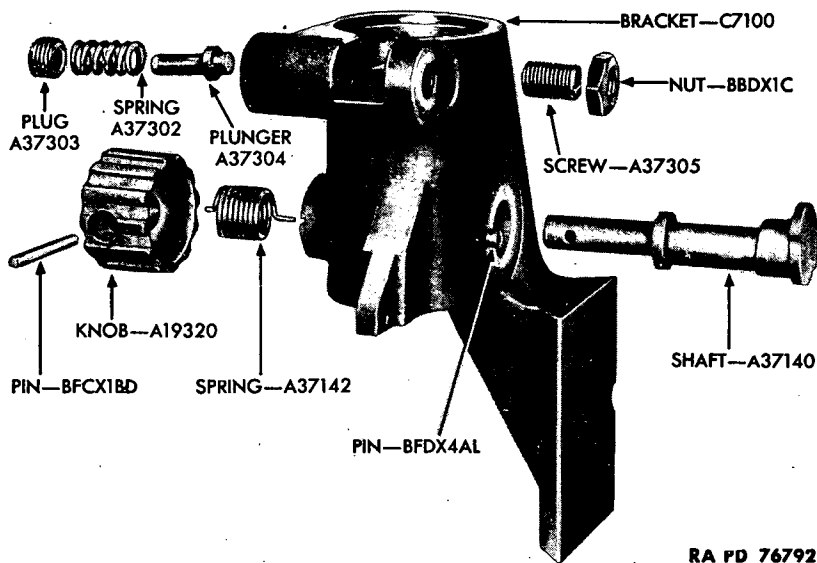

RA PD 76792

Figure 60—Sight Bracket Group—Exploded View

(c) Using a $\frac{1}{16}$ -inch pin drive punch and hammer, drive the straight pin out of piston rod latch lever and piston rod latch stem. Remove lever, stem, and latch spring.

(3) DISASSEMBLY OF SIGHT BRACKET (fig. 60).

(a) To remove sight bracket from cradle, remove cap screw and washer. Then drive out straight pin BFDX1EK (fig. 57).

(b) Remove nut BBDX1C and screw A37305. Using a jeweler's screwdriver, unscrew and remove sight socket plunger plug, and push out sight socket plunger and spring.

(c) Tap out tapered pin BFCX1BD from sight retaining shaft knob and shaft. Pull knob off shaft and pull shaft out. The shaft spring can be pried out with a screwdriver.

(4) REMOVAL OF CRADLE LOCKING PIN. There are four of these cradle locking pins, two front and two rear. All are removed in the same manner.

(a) Drive straight pin out of cradle and cradle locking pin (fig. 61).

(b) Then using improvised driving bar (fig. 33), drive locking pin out of cradle (fig. 62).

MAINTENANCE OF PACK HOWITZER CARRIAGES M1 AND M8

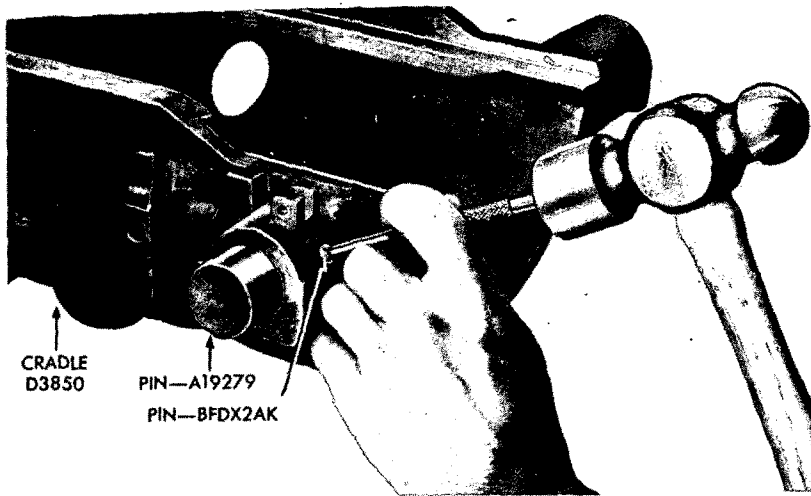

RA PD 76019

Figure 61—Removing Cradle Rear Locking Pin Retaining Pin

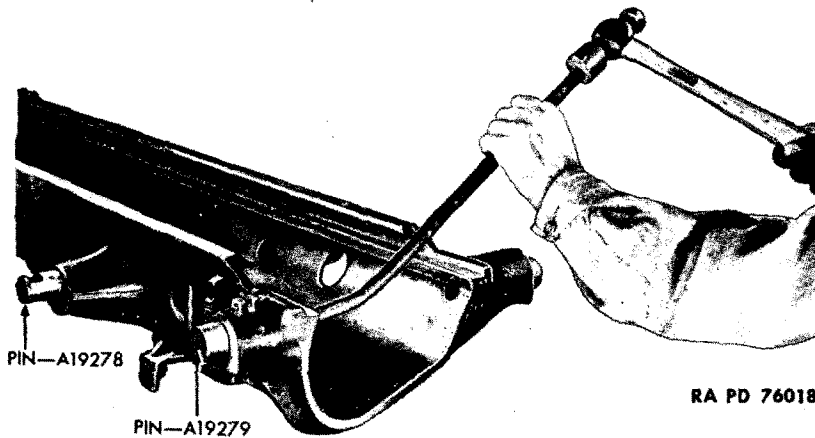

RA PD 76018

Figure 62—Removing Cradle Rear Locking Pin

c. Repairs.

- (1) Clean all parts of cradle thoroughly.
- (2) Examine all parts carefully for cracks, wear, or breakage.
- (3) Replace all worn or damaged parts.

**ORDNANCE MAINTENANCE
75-MM HOWITZERS AND CARRIAGES**

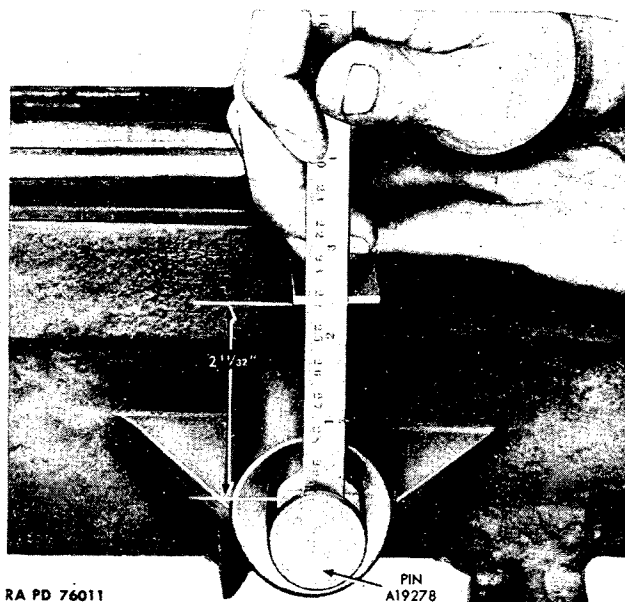

Figure 63—Checking Front Cradle Locking Pin

(4) Remove scores or bruises from cradle guides with a smooth file, and polish with crocus cloth. Remove only enough metal to remove bur or score. Then clean guides thoroughly.

d. Assembly and Installation.

(1) INSTALLATION OF CRADLE LOCKING PIN.

(a) Drive the new locking pin into place in the cradle, using a block of wood and hammer.

(b) When in properly, the rear locking pins should extend thirteen-sixteenths inch beyond face of boss on cradle. The front pin must have the slot in an upright position and parallel with top surface of cradle. The distance from top of cradle to slot at front and back should be $2\frac{11}{32}$ inches (fig. 63). The front pin should extend $1\frac{7}{16}$ inches from face of boss.

(c) When pin is installed properly, as above, drill and ream a hole through new locking pin using hole in boss as guide. Drill and ream the hole to 0.250 x 0.001 inch. Then drive in the retaining straight pin and peen over both ends.

(2) ASSEMBLY OF SIGHT BRACKET.

MAINTENANCE OF PACK HOWITZER CARRIAGES M1 AND M8

(a) Slide sight retaining shaft in place in sight bracket. Then insert spring, making certain to get end of spring in hole in shoulder of shaft, and other end of spring in slot in bracket. The spring must have one-quarter turn for tension before inserting spring end in slot in bracket.

(b) Slide the sight retaining shaft knob in place on shaft and secure with taper pin. NOTE: If a new knob or shaft is being installed, drill and ream for a No. 0 tapered pin.

(c) Slide sight socket plunger and spring in position in bracket, followed by sight socket plunger plug. Then screw nut on round-point headless screw and screw into place in bracket. Tighten nut against bracket.

(d) Slide the sight bracket into position on cradle and secure with straight pin, cap screw, and washer (fig. 57).

(3) ASSEMBLY OF PISTON ROD LATCH AND LEVER (figs. 58 and 59).

(a) Place the spring on piston rod latch stem and insert them into place in cradle. Secure piston rod latch lever to stem with straight pin. Test for action.

(b) Drop the piston rod latch down into retaining grooves in cradle front transom. Then replace the screw and washer. Test for locking action.

28. EQUILIBRATORS.**a. General.**

(1) Two equilibrators of the spring type are provided to balance the weight of the howitzer muzzle and reduce manual effort required to

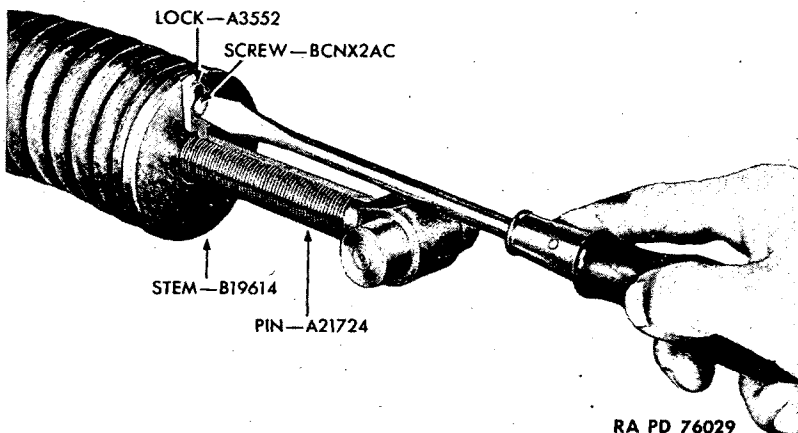

Figure 64—Removing Equilibrator Pin Lock

**ORDNANCE MAINTENANCE
75-MM HOWITZERS AND CARRIAGES**

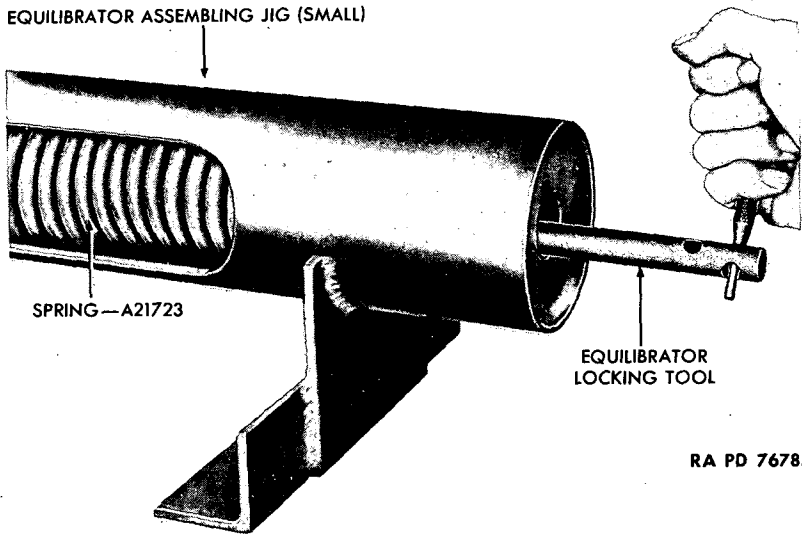

Figure 65—Removing Equilibrator Locking Tool

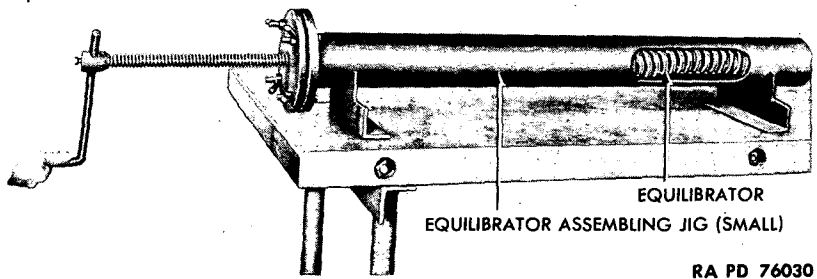

Figure 66—Disassembling Equilibrator

elevate and depress the howitzer.

(2) The equilibrator is composed of the barrel, stem, helical spring, stem plug, pin lock, and lock screw (fig. 67).

(3) The equilibrator spring pressure is adjustable within limits, to secure the least and most uniform resistance to elevation and depression.

MAINTENANCE OF PACK HOWITZER CARRIAGES M1 AND M8

RA PD 76807

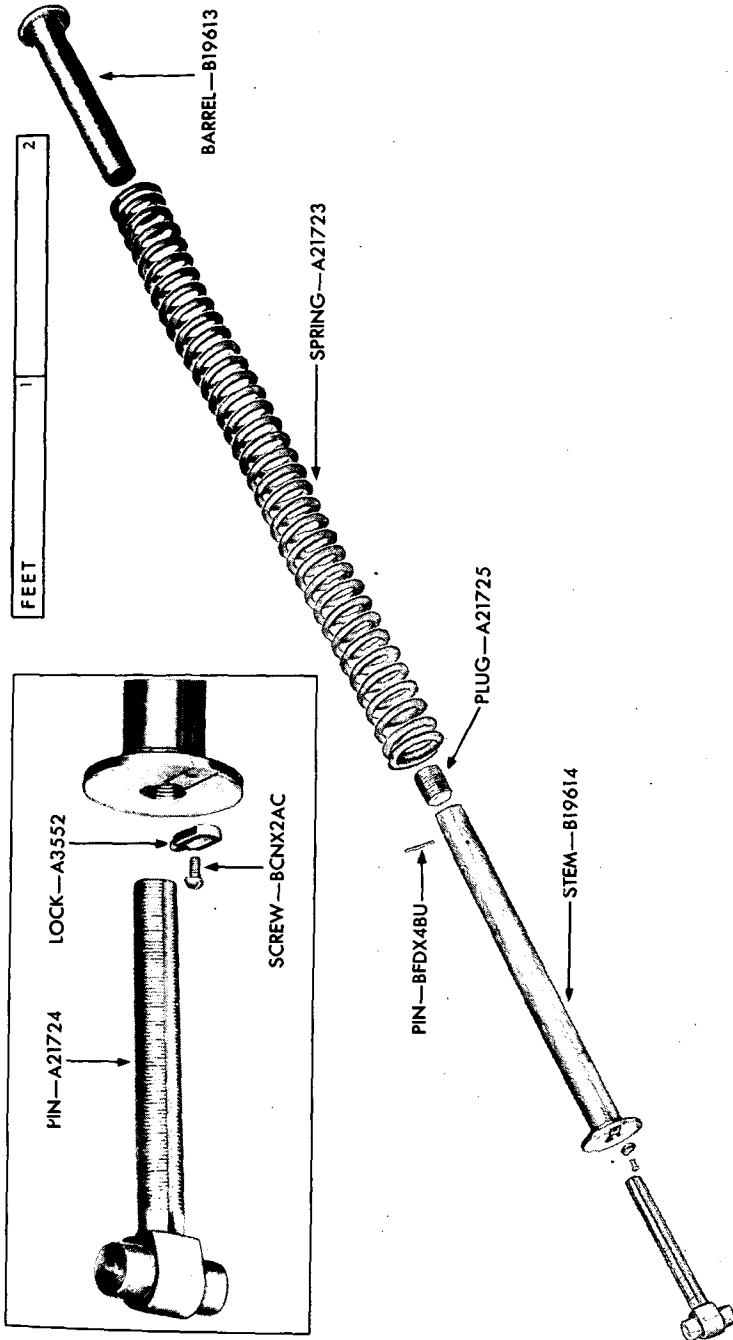

Figure 67—M1 and M8 Equilibrators—Exploded View

**ORDNANCE MAINTENANCE
75-MM HOWITZERS AND CARRIAGES**

(4) The rear end of the equilibrator barrel and plug is designed to receive the equilibrator locking tool (figs. 30 and 65). This tool is used to hold the equilibrator spring in the compressed position while the equilibrator is being removed or installed. The load on the spring when the locking tool is in position is approximately 1,400 pounds.

b. Removal and Disassembly.

(1) Removal of equilibrators from carriage is covered in TM 9-319 and TM 9-320.

(2) DISASSEMBLY OF EQUILIBRATOR.

(a) Remove the round-head machine screw and equilibrator lock from the trunnion pin and stem (fig. 64). Unscrew and remove the trunnion pin.

(b) Place the equilibrator in the assembling jig (small size) (fig. 32) with the assembling tool projecting through hole in rear of jig (fig. 64). *NOTE: If assembling jig is not available and one cannot be improvised like this one, do not attempt disassembly of equilibrator. Replace equilibrator as unit.*

(c) Tighten front cover of assembling jig in position and, by turning handle on jig screw, remove tension from the equilibrator locking bolt tool (fig. 66).

(d) Then remove equilibrator locking tool, back off on jig screw, remove front cover from jig, and remove equilibrator parts (fig. 67).

(e) To remove plug from equilibrator stem, drive out straight pin and unscrew plug. The equilibrator is then fully disassembled.

c. Repairs.

(1) Clean all parts of equilibrator thoroughly.

(2) Examine all parts carefully for cracks, wear, or breakage.

(3) Replace all worn or damaged parts.

d. Assembly and Installation.

(1) ASSEMBLY OF EQUILIBRATOR.

(a) If removed, screw the plug in place in the equilibrator stem and secure with straight pin.

(b) Place the equilibrator in position on the stem, then insert the equilibrator barrel in the other end of spring.

(c) Place these units in the assembling jig, making certain to get the barrel end of equilibrator facing rear of jig.

(d) Compress unit and screw equilibrator assembling or locking tool into end of barrel. The tool should not project beyond rear face of jig over 5 inches.

MAINTENANCE OF PACK HOWITZER CARRIAGES M1 AND M8

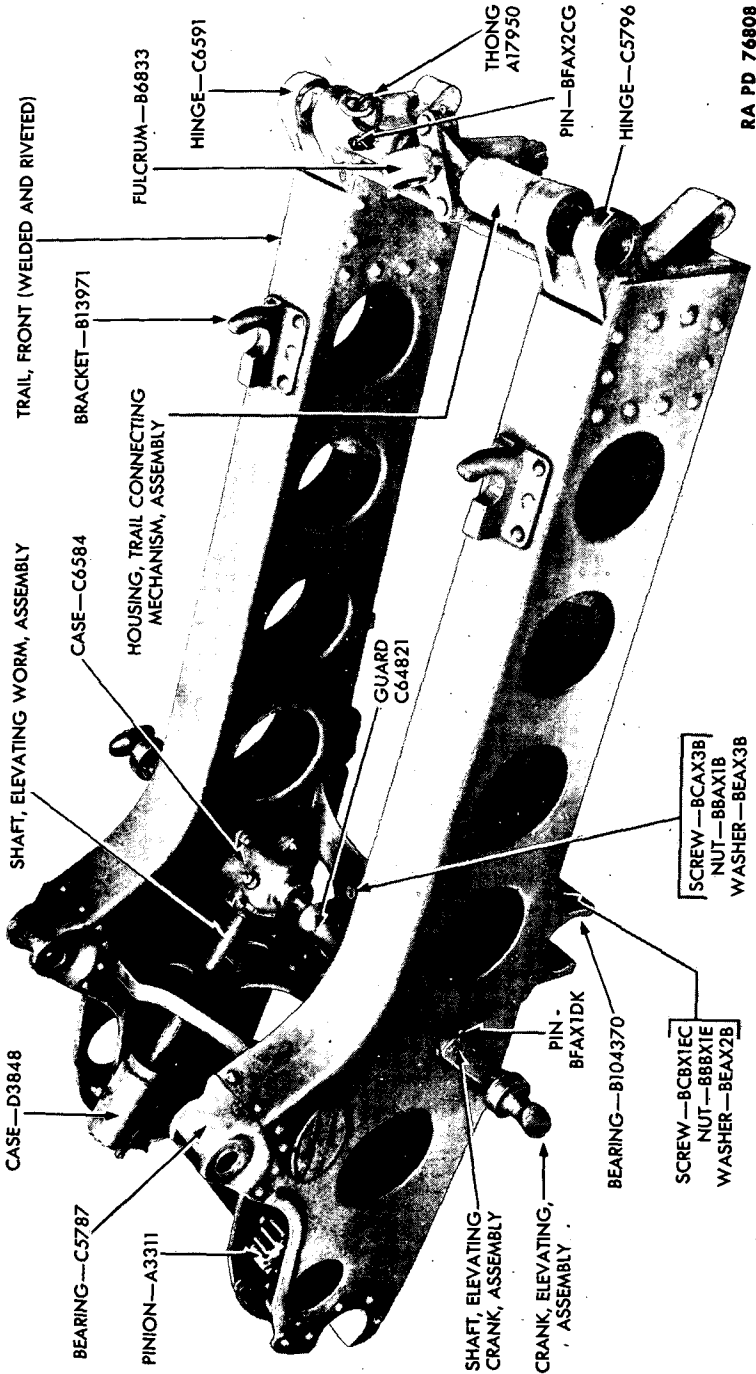

RA PD 76808

Figure 68—Front Trail Assembly

ORDNANCE MAINTENANCE
75-MM HOWITZERS AND CARRIAGES

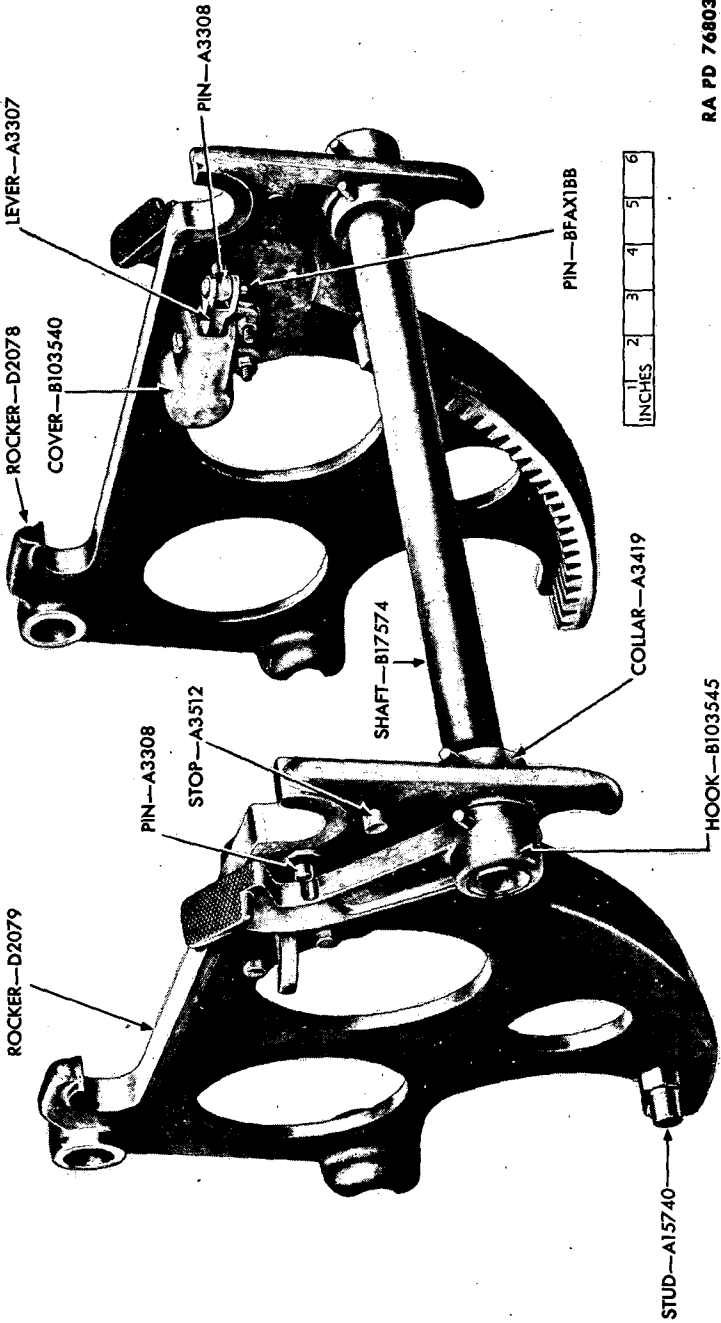

Figure 69—Rocker Assembly

MAINTENANCE OF PACK HOWITZER CARRIAGES M1 AND M8

RA PD 76810

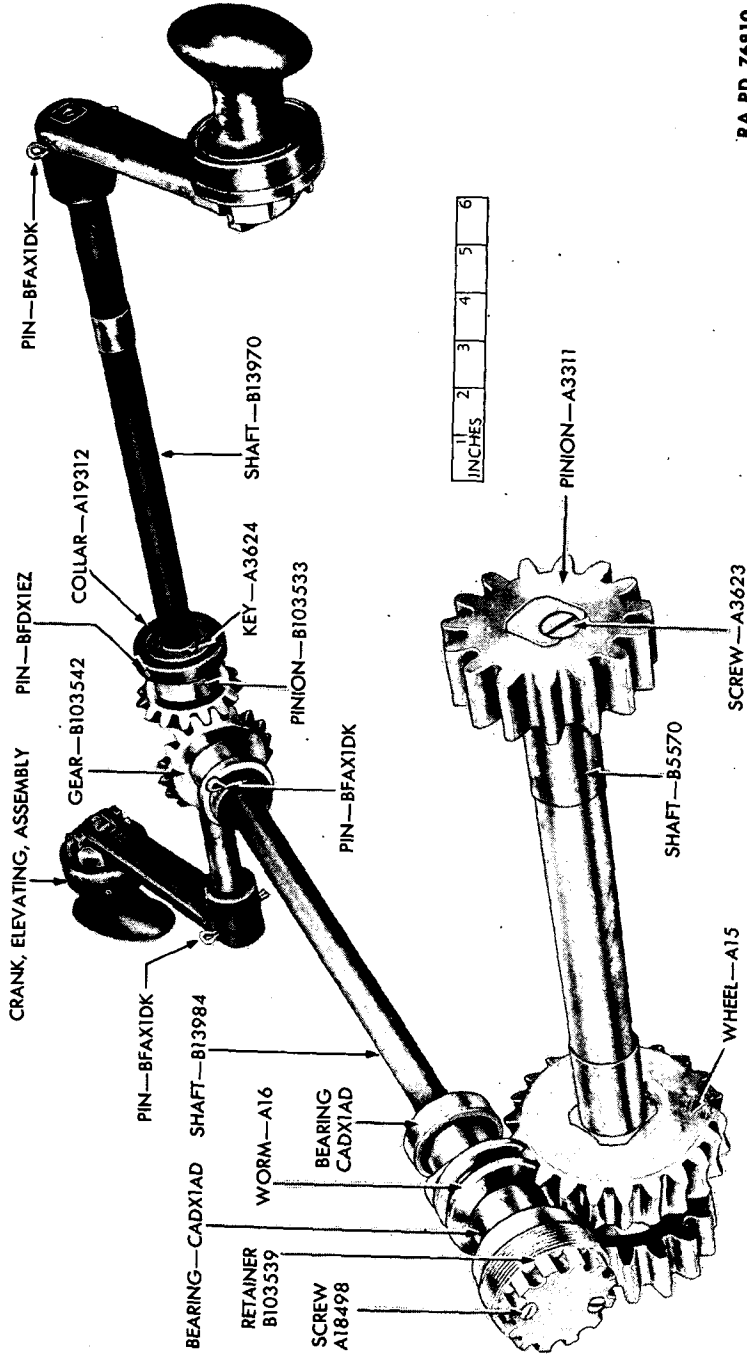

Figure 70—Elevating Mechanism Arrangement

**ORDNANCE MAINTENANCE
75-MM HOWITZERS AND CARRIAGES**

(e) Remove the equilibrator from the assembling jig. Screw the equilibrator trunnion pin into the stem until distance between bottom of cross bar on pin and face of stem is $4\frac{1}{2}$ inches. Then secure in place with equilibrator lock and screw. Equilibrator is adjusted after carriage is assembled, if necessary.

(2) **INSTALLATION OF EQUILIBRATOR.** The procedure for this is outlined in TM 9-319 and TM 9-320.

29. ELEVATING MECHANISM.

a. General.

(1) The elevating mechanism is contained within, and transported with, the front trail (fig. 68). The rocker assemblies, to which the cradle is rigidly attached when in firing position, rest in the trunnion bearings of the front trail.

(2) These rockers are segments of internal gears which mesh with pinions mounted on the ends of the rocker pinion shaft (fig. 69). The rocker pinion shaft rotates in bearings mounted in the front trail side members.

(3) Two elevating cranks, mounted at the ends of a shaft, rotate the pinion shaft through a train of bevel and worm gears (fig. 70).

b. Removal and Disassembly of Elevating Mechanism.

CAUTION: When the elevating mechanism is removed and disassembled with the top carriage assembled to the bottom carriage, never disassemble the elevating mechanism without first locking or removing the equilibrators.

(1) Removal of rocker assembly from carriage is outlined in TM 9-319 and TM 9-320.

(2) Removal of elevating mechanism integral with front trail constitutes disassembly of elevating mechanism other than rocker assembly (step (3), below).

(3) DISASSEMBLY OF ROCKER ASSEMBLY (figs. 69 and 71).

(a) Remove taper pins from both trunnion hooks, and slide or tap hooks off rocker connecting shaft. Then slide rockers off the shaft. Do not remove either of the two rocker connecting shaft collars unless damaged. Then remove the same as trunnion hooks (figs. 69 and 71).

(b) Remove three cap screws, washers, and nuts holding trunnion hook latch cover to rocker, thus releasing spring A3349 (fig. 71).

(c) Remove cotter pins BFAX1CC and BFAX1BB from pins A3310 and BFFX1B respectively (fig. 71). Remove these two pins, and trunnion hook latch lever and trunnion hook latch pin A3308 will be released from cover. Disassemble the other rocker, if necessary, in the same manner.

MAINTENANCE OF PACK HOWITZER CARRIAGES M1 AND M8

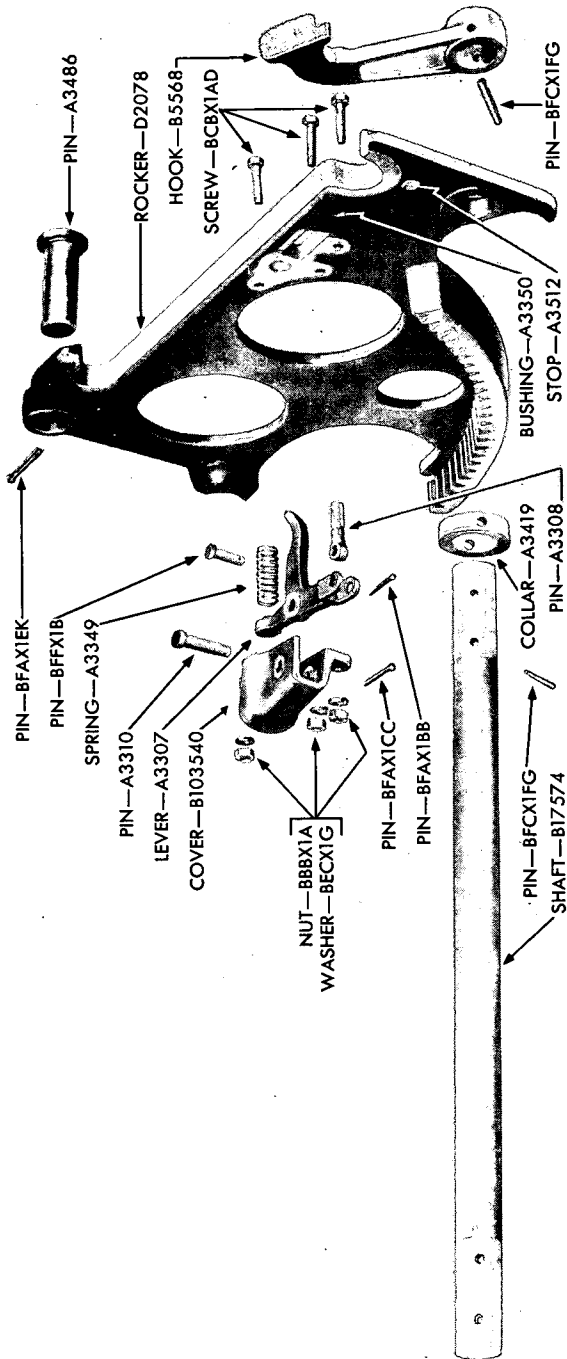

RA PD 76813

Figure 71—Rocker—Exploded View

| | | | | | |
|--------|---|---|---|---|---|
| 1 | 2 | 3 | 4 | 5 | 6 |
| INCHES | | | | | |

**ORDNANCE MAINTENANCE
75-MM HOWITZERS AND CARRIAGES**

(d) If bushing A3350 is worn, replace it with a new bushing. Ream new bushing to five-sixteenths inch.

(4) **REMOVAL AND DISASSEMBLY OF ELEVATING CRANK ASSEMBLY** (figs. 72 and 73).

(a) Remove cotter pin from elevating crank and elevating crank shaft. Pull crank off the shaft. Repeat to remove elevating crank from other end of shaft (fig. 72).

(b) Drive pin BFDX4BU from crank knob connection and knob, and unscrew knob from connection (fig. 73).

(c) Unscrew nut A3323 from crank spindle and remove spindle spring. Then separate elevating crank knob latch from knob connection.

(d) To remove elevating crank from crank spindle, drive the straight pin out of pin A3343 and remove.

(5) **REMOVAL AND DISASSEMBLY OF ELEVATING CRANK SHAFT** (figs. 74, 75, and 76).

(a) Remove elevating crank shaft guard by removing the four screws, nuts, and washers (fig. 74).

(b) Drive pin out of elevating crank shaft collar, and slide collar away from lower elevating gear case cover (fig. 75).



RA PD 76032

Figure 72—Removing Elevating Crank

MAINTENANCE OF PACK HOWITZER CARRIAGES M1 AND M8

RA PD 76804

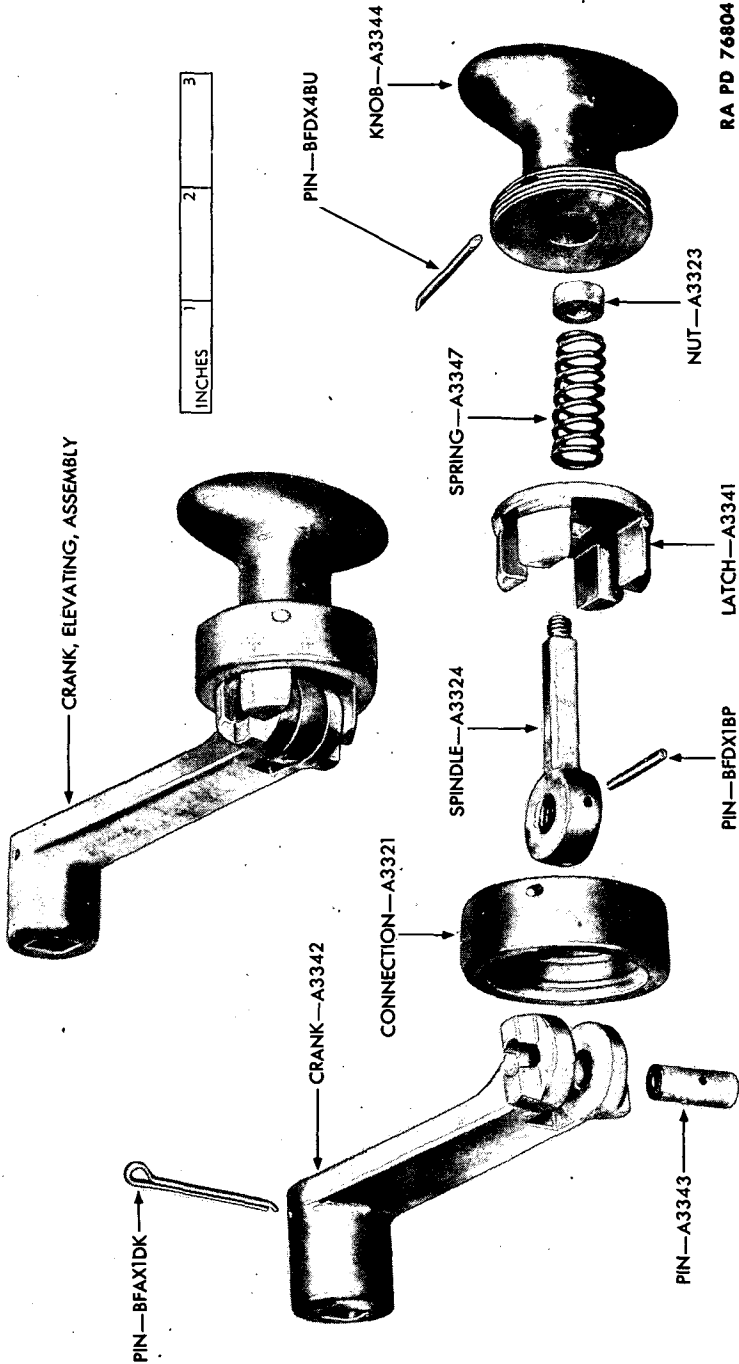

Figure 73—Elevating Crank

**ORDNANCE MAINTENANCE
75-MM HOWITZERS AND CARRIAGES**

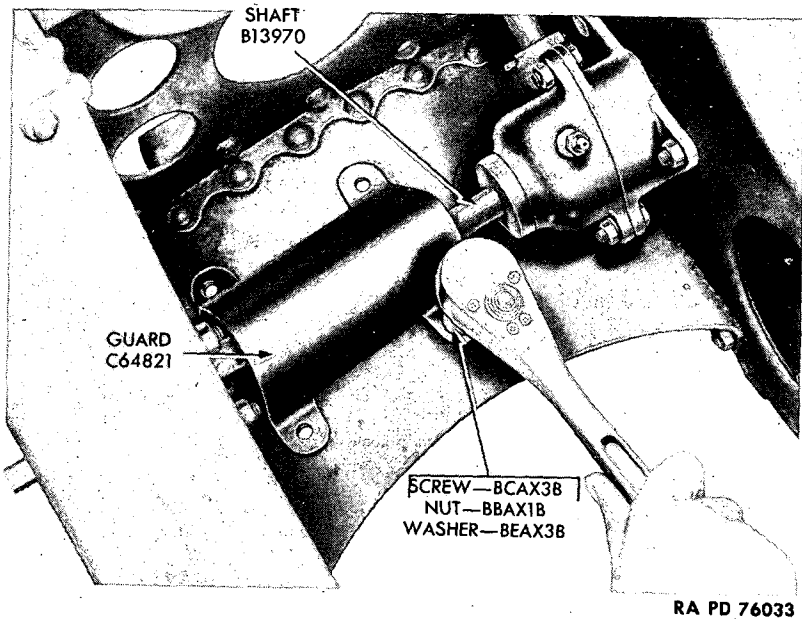

Figure 74—Removing Elevating Crankshaft Guard

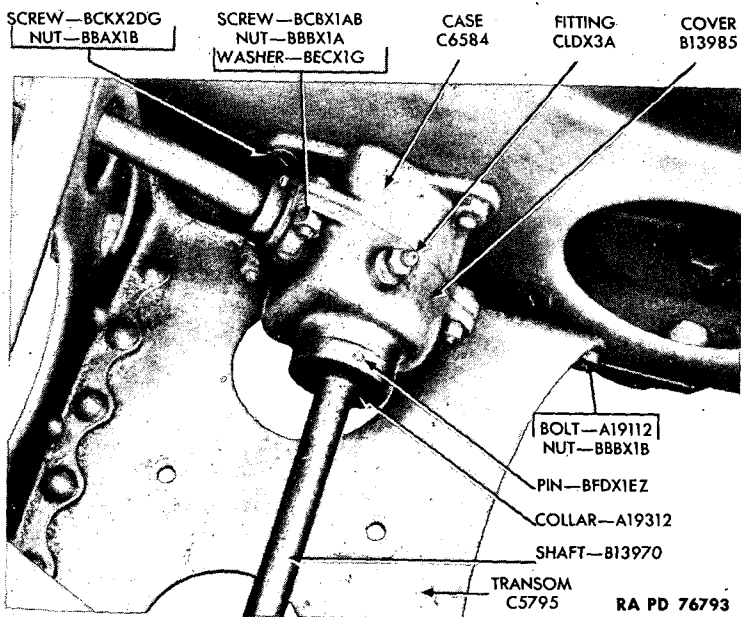

Figure 75—Lower Elevating Gear Case Group

MAINTENANCE OF PACK HOWITZER CARRIAGES M1 AND M8

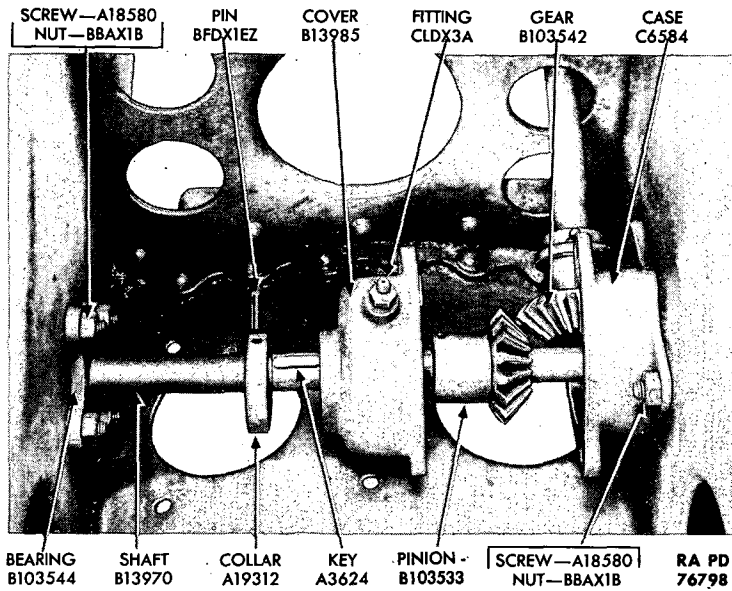

Figure 76—Lower Elevating Gear Case Cover Removed

(c) Remove the three screws, nuts, and washers from lower elevating gear case cover and case. Separate gear case and cover. Remove elevating crank shaft key from shaft. Then pull elevating crank shaft out and remove collar, gear case cover, and elevating pinion (fig. 76).

(6) REMOVAL OF ELEVATING WORM SHAFT.

(a) Unscrew retainer lock screw, so that retainer can be removed from upper elevating gear case. Use elevating worm spanner wrench B103690 provided for this purpose (figs. 28 and 77).

(b) Remove cotter pin from bevel elevating gear and elevating worm shaft. Remove gear from shaft, then rotate shaft and remove worm shaft and rear ball bearing through front of upper elevating gear case.

(c) To remove the ball bearing from the retainer, remove two screws, then use a pin drive punch and hammer (fig. 78). **NOTE:** The two ball bearings on the worm shaft are interchangeable.

(7) REMOVAL AND DISASSEMBLY OF ROCKER PINION SHAFT.

(a) Remove rocker pinion screw and pull rocker pinion from the rocker pinion shaft (fig. 79).

**ORDNANCE MAINTENANCE
75-MM HOWITZERS AND CARRIAGES**

CASE—D3848

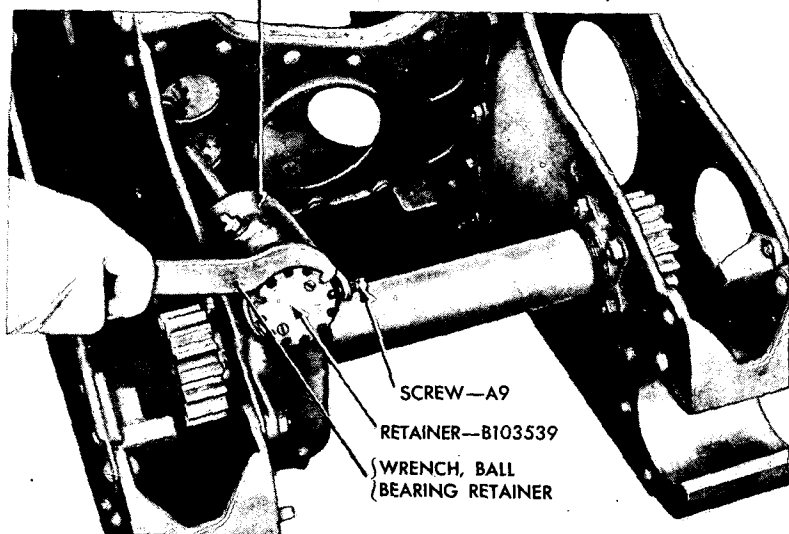

RA PD 26125

Figure 77—Removing Ball Bearing Retainer

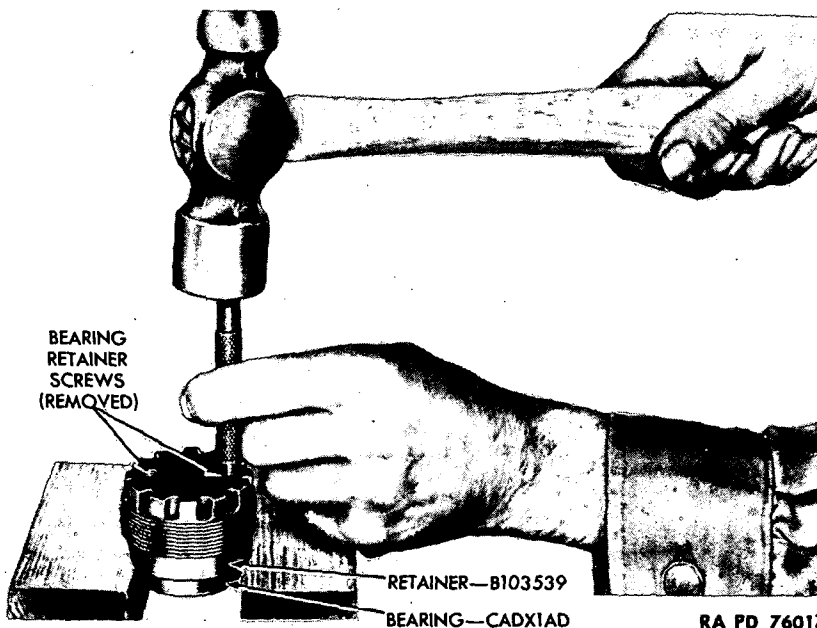

RA PD 76017

Figure 78—Removing Bearing From Retainer

MAINTENANCE OF PACK HOWITZER CARRIAGES M1 AND M8

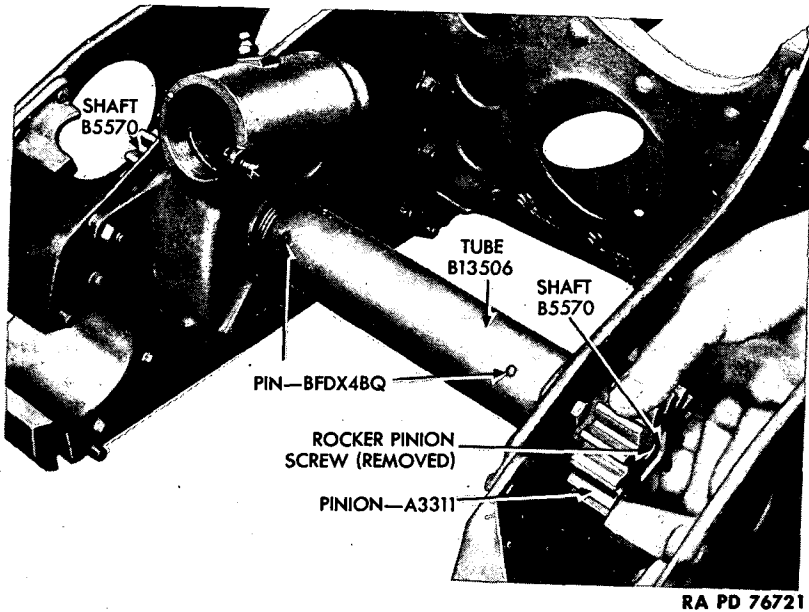

RA PD 76721

Figure 79—Removing Rocker Pinion

(b) Draw shaft out of rocker pinion shaft tube from right side of front trail. It may be necessary to tap shaft, using a brass drift and hammer, in order to remove it.

(c) Remove elevating worm wheel from upper elevating gear case.

c. Repairs.

(1) Clean all parts of elevating mechanism and rocker assemblies thoroughly.

(2) Examine all parts carefully for cracks, wear, or breakage.

(3) Replace all worn or damaged parts.

(4) Replace broken or damaged rocker pinion shaft tube, upper elevating gear case, or rocker pinion shaft tube bearing (fig. 80).

(a) Remove the two pins BFDX4BQ from the rocker pinion shaft tube.

(b) Remove one screw and four bolts, nuts, and washers from gear case. Unscrew four bolts, washers, and nuts from tube bearing, but leave in one bolt to prevent bearing from turning.

(c) Turn tube toward the front transom in front trail. This will permit removal of tube, case, and bearing from trail. Then unscrew tube from case and bearing.

**ORDNANCE MAINTENANCE
75-MM HOWITZERS AND CARRIAGES**

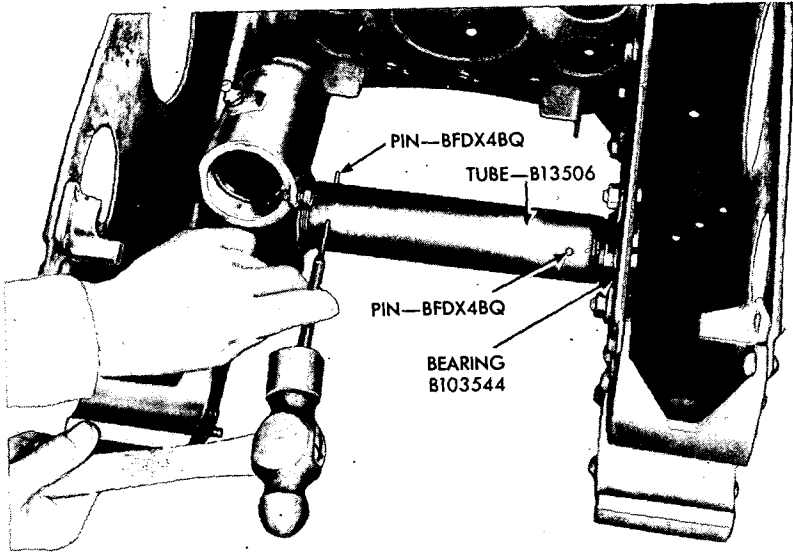

RA PD 76722

Figure 80—Removing Rocker Pinion Shaft Tube

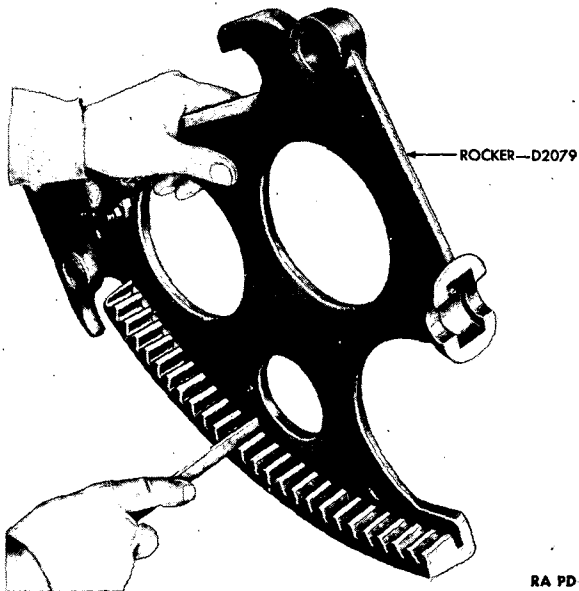

RA PD 76720

Figure 81—Filing Rocker Teeth

MAINTENANCE OF PACK HOWITZER CARRIAGES M1 AND M8

(d) Replace worn or damaged parts with new ones.

(e) Screw tube on gear case as far as possible. Screw bearing in tube until it shoulders. Place the unit in trail and secure gear case to trail with proper bolts, nuts, and washers. NOTE: One screw and two dowel pins are also used in mounting gear case on trail.

(f) Unscrew the bearing from the tube until about half the threads on the bearing are exposed. Then turn tube away from trail transom until the bearing seats against trail.

(g) Secure bearing to trail with four bolts, washers, and nuts. Tighten tube until pin holes in tube, case, and bearing line up, then install the two straight pins.

(h) In case a new bearing is being installed, ream the bearing to 1.062-inch diameter. Also drill a $\frac{3}{16}$ -inch hole through bearing for a straight pin. If a new gear is used, ream it to 1.375-inch diameter with a line reamer. Drill a hole for $\frac{3}{16}$ -inch straight pin.

(5) REMOVE BURS AND NICKS FROM ROCKER TEETH. (fig. 81).

(a) Remove all burrs, nicks, or rough spots from rocker teeth by using a smooth file. Then polish with crocus cloth.

(b) Be certain to remove only enough metal to restore contour of tooth. Clean thoroughly.

(c) Scores, bruises, nicks, etc., are removed from worm, worm wheel, and bevel and pinion gears in the same manner.

d. Assembly and Installation.**(1) INSTALL ROCKER PINION SHAFT.**

(a) Place the worm wheel in the upper elevating gear case and insert the rocker pinion shaft in position in gear case, tube, and bearing. NOTE: The rocker pinion shaft must be inserted from the right side of trail through trail lightening hole in trail side member.

(b) Slide rocker pinion in place on the rocker pinion shaft and secure with screw.

(c) Check rocker shaft for freedom of action.

(2) INSTALL ELEVATING WORM SHAFT.

(a) Slide one of the ball bearings on the worm shaft up against the rear of the worm. Insert the worm shaft through the gear case. Rotate the worm shaft until worm and worm wheel are in proper mesh and ball bearing is seated in the gear case.

(b) Slide the bevel elevating gear in place on the lower end of the worm shaft and secure with cotter pin.

(c) Tap the other ball bearing in place in the retainer. Replace the two screws in the retainer, then screw the retainer in place in the upper gear case with wrench B103690 (figs. 28 and 77). Lock the retainer in place by means of the lock screw.

**ORDNANCE MAINTENANCE
75-MM HOWITZERS AND CARRIAGES****(3) INSTALL ELEVATING CRANK SHAFT.**

(a) Slide the elevating crank shaft in through the shaft bearing in left side of trail. Slide the following on the shaft in the order named: crank shaft collar, lower elevating gear case cover, and elevating pinion (fig. 76).

(b) Insert the key in the shaft. Place pinion in mesh with bevel elevating gear, then tap elevating crank shaft and key into place in the pinion.

(c) Tap lower elevating gear case cover into position on hub of pinion and up against mating surface of lower gear case. Secure cover to case with three screws, washers, and nuts.

(d) Tap crank shaft collar into place up against gear case cover and on hub of pinion. Line up hole in collar with hole in pinion hub. Secure collar in place with straight pin.

**(4) ASSEMBLY AND INSTALLATION OF ELEVATING CRANKS
(fig. 73).**

(a) Place the crank spindle in position in the crank. Insert the crank spindle pin and fasten with straight pin.

(b) Place crank knob latch in the knob connection and slide this unit onto crank spindle. Follow with spindle spring, then screw spindle nut on the spindle.

(c) Screw crank knob into crank connection. Line up pinholes in each, and drive in the straight pin. Assemble other elevating crank in same manner.

(d) Tap the elevating cranks on the ends of the elevating crank shaft. Make certain that the cranks are mounted on the shaft at 180 degrees from each other. (One will be up while the other is down.) Secure each crank to the shaft with a cotter pin (fig. 72).

(5) ASSEMBLY OF ROCKERS (figs. 69 and 71).

(a) Place the trunnion hook latch lever in place in the trunnion hook latch cover. Insert pin A3310 and secure with cotter pin BFAX1CC. Assemble pin A3308 to lever with straight pin BFFX1B and cotter pin BFAX1BB.

(b) Place this unit in position on the inside of the rocker, making certain to get the spring A3349 in properly. Secure cover to rocker with three cap screws, washers, and nuts.

(c) Slide rocker on rocker connecting shaft up against rocker connecting shaft collar. Follow with the trunnion hook. Secure hook to shaft with taper pin.

(d) The other rocker assembly is assembled and mounted on the shaft in the same manner as outlined in steps (a), (b) and (c), above.

MAINTENANCE OF PACK HOWITZER CARRIAGES M1 AND M8

(6) **INSTALLATION OF ROCKER ASSEMBLY.** This is covered in TM 9-319 and TM 9-320.

(7) Make certain that the elevating mechanism is properly lubricated after assembly. Lubrication instructions are given in section X.

30. TRAVERSING MECHANISM AND AXLE.

a. General (fig. 82).

(1) The traversing mechanism is integral with the axle. This construction provides an axle traverse of 3 degrees to the right and 3 degrees to the left.

(2) The axle is a round steel bar bored out at each end to accommodate the axle arms. The left arm is pinned, whereas the right arm is attached to the axle with a screw to facilitate disassembly and assembly.

(3) The axle is retained in the trail bearings by means of a sleeve. This axle sleeve fits in the trail bearings so that the sleeve cannot rotate or move transversely. It also furnishes a sliding connection between the axle and the trail bearings, and carries the traversing mechanism.

(4) The sleeve may be inserted by matching the proper surfaces. It is locked in position by turning the hinged handle lock 90 degrees. The hinged handle lock serves as a lever to turn the axle sleeve.

(5) The body of the axle is graduated in mils for traverse, the right end of the axle sleeve forming the index of the graduations. The axle is grooved near the left end to form an inner race for the traversing mechanism ball bearings, which act as threads in traversing.

(6) The traversing mechanism is composed of the traversing nut, handwheel, handwheel machine screw, ball bearing, ball bearing cap, ball bearing nut, and 71 $\frac{5}{16}$ -inch diameter steel balls.

(7) The bellows-like dust cover between the axle arm and traversing handwheel prevents the entry of dirt or foreign matter into the traversing mechanism. It also protects the grooved portion of the axle not covered by the axle sleeve. This dust cover does not rotate with the traversing handwheel.

(8) When the materiel is transported on its wheels, the axle is locked to the front trail by means of the axle sleeve lock. The hold-down cable is attached to the traversing handwheel and acts as a holding device for the top sleigh assembly.

b. Removal and Disassembly.

(1) Removal of axle and traversing mechanism from carriage is outlined in TM 9-319 and TM 9-320.

ORDNANCE MAINTENANCE
75-MM HOWITZERS AND CARRIAGES

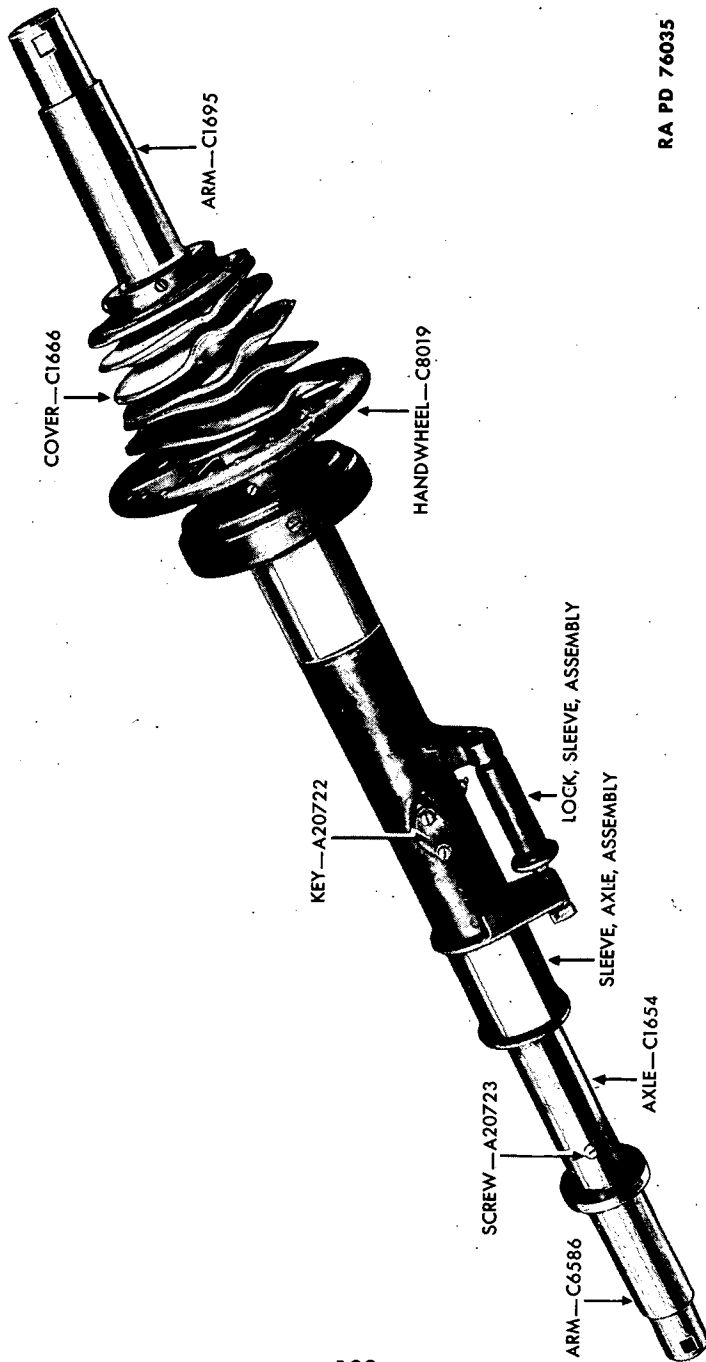

RA PD 76035

Figure 82—Axle and Traversing Mechanism Assembly—M1 and M8 Carriages

MAINTENANCE OF PACK HOWITZER CARRIAGES M1 AND M8

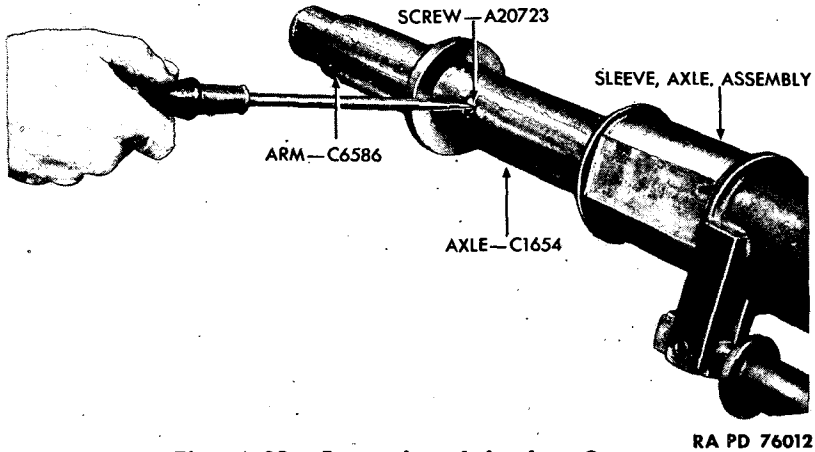

Figure 83—Removing Axle Arm Screw

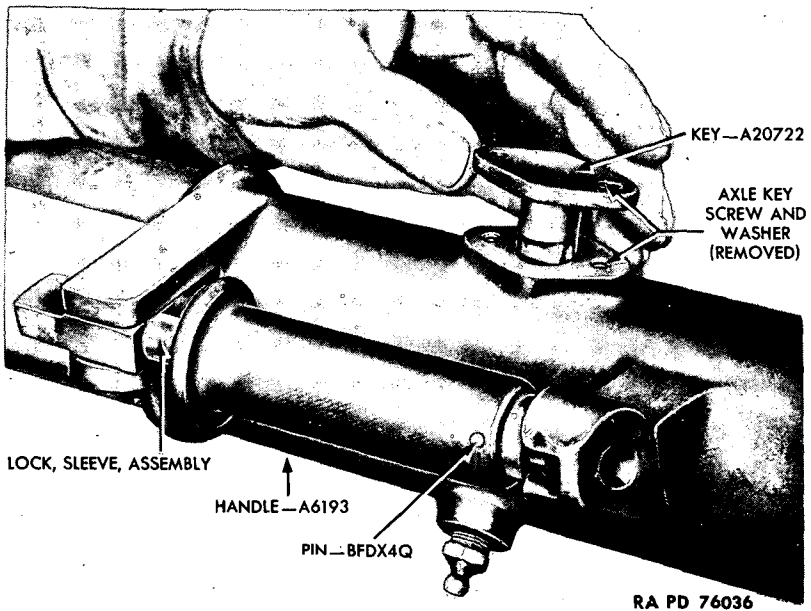

Figure 84—Removing Axle Lock Key

(2) DISASSEMBLY OF AXLE AND TRAVERSING MECHANISM.

(a) Remove axle arm screw (fig. 83) and unscrew and remove axle arm from axle. This is a left-hand thread.

(b) Remove the two screws and washers from the axle key. Lift axle key out of axle sleeve (fig. 84).

ORDNANCE MAINTENANCE
75-MM HOWITZERS AND CARRIAGES

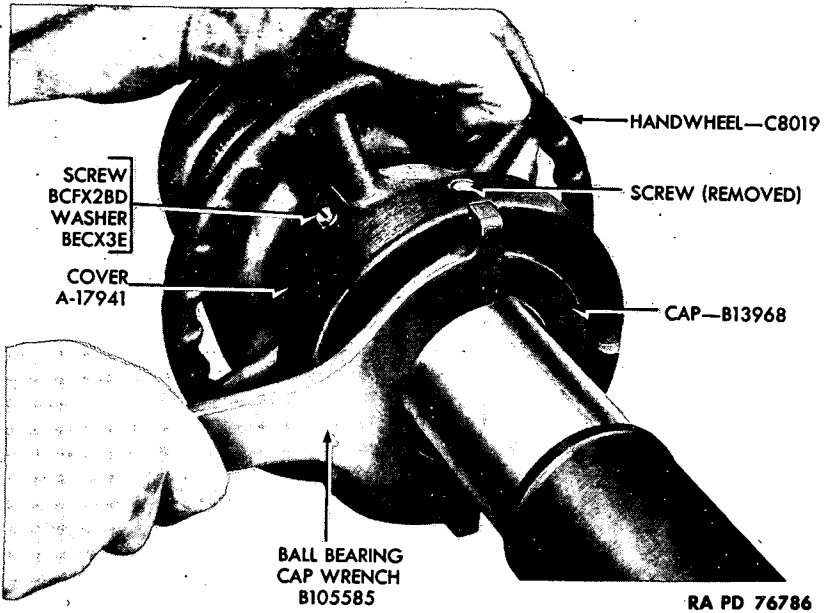

Figure 85—Removing Ball Bearing Cap

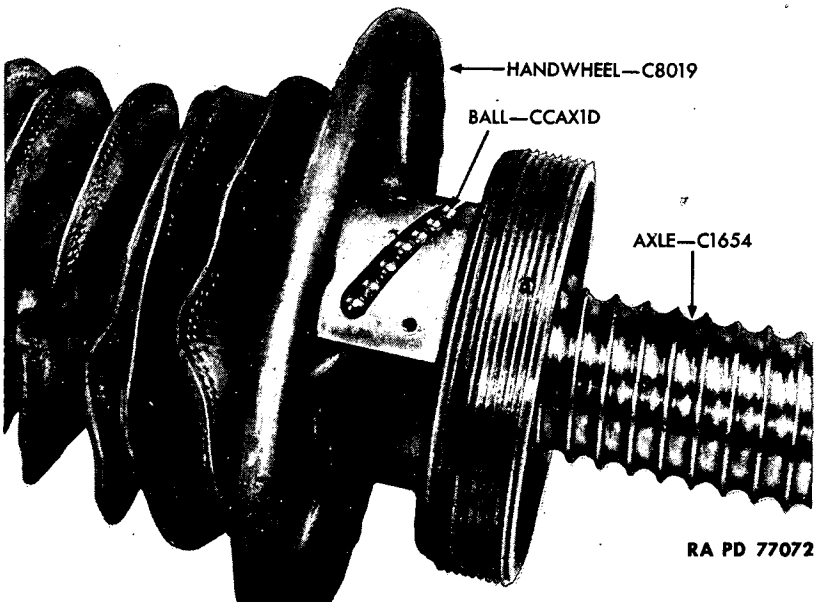
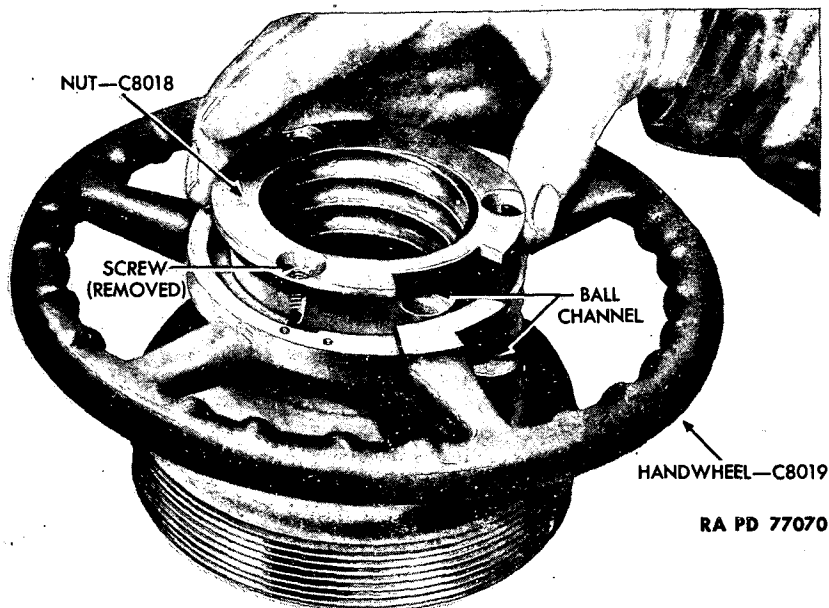

Figure 86—Ball Cover Removed From Handwheel

MAINTENANCE OF PACK HOWITZER CARRIAGES M1 AND M8



RA PD 77070

Figure 87—Removing Traversing Nut

(c) Remove the set screw from ball bearing cap and traversing handwheel. Using ball bearing cap wrench B105585, unscrew ball bearing cap (fig. 85). Slide axle sleeve off of axle.

(d) Remove two screws and washers from ball cover and remove cover. Allow balls to fall out (fig. 86) by turning axle. Be sure all 71 balls are out. Put in container so they will not be lost.

(e) Remove the six screws and both halves of inner dust cover clip. Remove the handwheel from axle, being careful not to damage threads (fig. 88).

(f) Remove six screws and both halves of outer dust cover. Slide dust cover from the axle (fig. 88).

(g) Remove three screws from traversing nut and lift nut out of handwheel (fig. 87).

(3) **DISASSEMBLY OF AXLE SLEEVE** (fig. 88).

(a) Remove ball bearing lock nut and lock washer.

(b) Tap ball bearing off axle sleeve, then slide the ball bearing cap from sleeve.

(c) Remove pin BFDX2CF (fig. 88) from sleeve lock. This will permit sleeve lock assembly to come away from axle sleeve as a unit.

ORDNANCE MAINTENANCE
75-MM HOWITZERS AND CARRIAGES

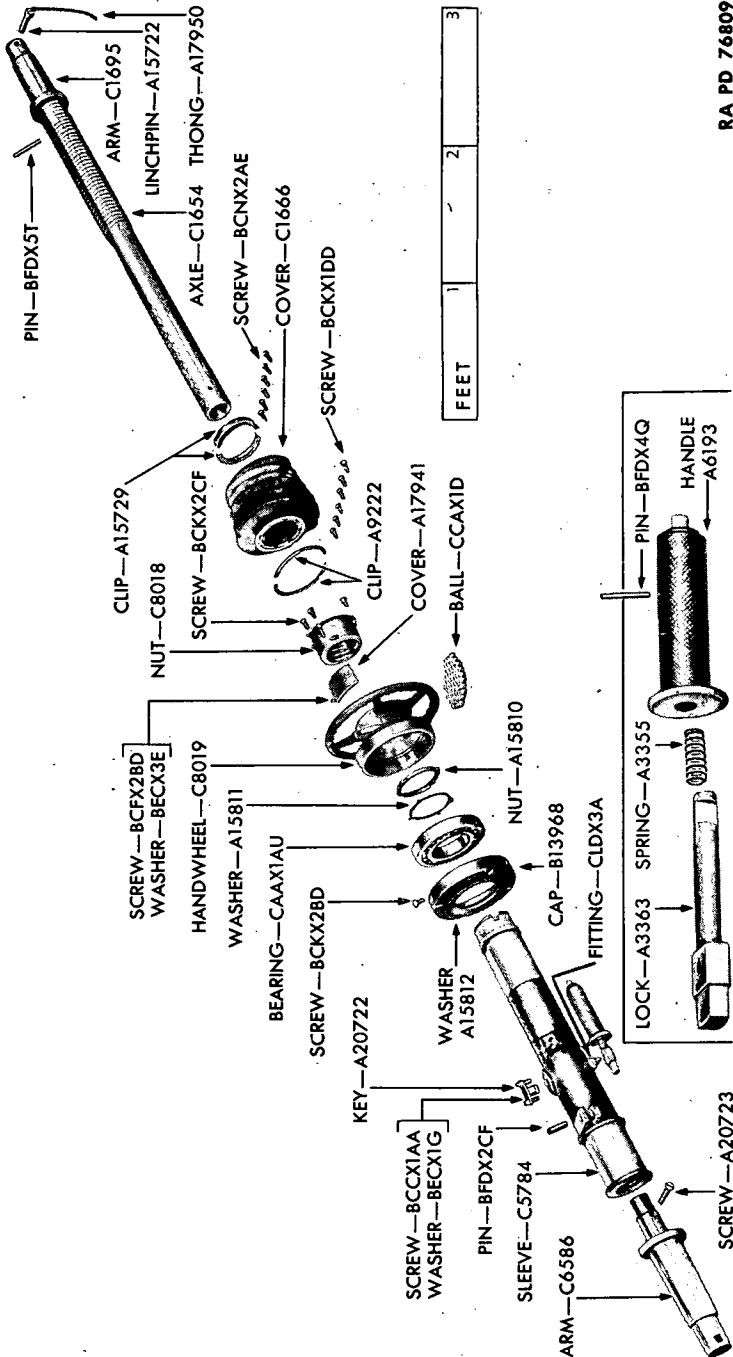

RA PD 76809

Figure 88—M1 and M8 Traversing Mechanism—Exploded View

MAINTENANCE OF PACK HOWITZER CARRIAGES M1 AND M8

(d) To disassemble sleeve lock, drive pin BFDX4Q (fig. 88) from sleeve lock handle. Spring and lock can then be removed from handle.

c. Repairs.

- (1) Clean all parts of traversing mechanism and axle thoroughly.
- (2) Examine all parts carefully for cracks, wear, or breakage.
- (3) Replace all worn or damaged parts.

d. Assembly and Installation.**(1) ASSEMBLE AXLE SLEEVE (fig. 88).**

(a) Place the sleeve lock spring in the sleeve lock handle. Push sleeve lock in place in handle until straight pin can be inserted through handle and slot in lock. Place this assembly in place on the axle sleeve and secure with straight pin. Peen over ends of pin.

(b) Slide the ball bearing cap in place on the axle sleeve. Tap ball bearing in place in cover and on sleeve. Place the lock washer on the sleeve and hold with lock nut. Tighten nut.

(2) ASSEMBLE HANDWHEEL.

(a) Slide the traversing nut into position in the handwheel.

(b) Make certain that it seats properly, then secure in place with three screws.

(3) ASSEMBLE AXLE AND TRAVERSING MECHANISM.

(a) Secure the dust cover to the axle flange with both halves of outer dust cover clip and six screws.

(b) Slide the handwheel on the axle, working it over threads to dust cover.

(c) Be sure the balls are clean, then insert the 71 balls in the handwheel. Turn the axle, working the balls in until all 71 have been inserted. Secure the ball cover in place on handwheel with two screws and washers (figs. 86 and 87).

(d) Rotate handwheel, watching to make sure balls are rolling over passover. Lubricate the threads and axle. Stretch out dust cover and secure to handwheel with both halves of inner dust cover clip and six screws.

(e) Slide the axle sleeve on the axle. Push ball bearing on sleeve into the handwheel. Then screw the ball bearing cap on the handwheel, using ball bearing cap wrench B105585 (fig. 85). Align the holes in the cap and handwheel and screw set screw into place.

(f) Insert the axle key in place in axle sleeve and in slot in axle. Secure with two screws and washers (fig. 84).

(g) Screw axle arm into axle (left-hand thread) and secure with screw (fig. 90).

(4) **INSTALLATION OF AXLE AND TRAVERSING MECHANISM.** This is outlined in TM 9-319 and TM 9-320.

31. TRAILS.

a. General.

(1) The trail is of the modified box type. To facilitate disassembly for transport, the trail assembly is separated into two major components, the front trail and the rear trail (figs. 89 and 90). Each trail consists of a right and left member. Each of these members is formed of two flasks welded together to form a box-like section. The side members are connected by transoms. The front and rear trails are connected by means of the trail connecting mechanism (fig. 91). This mechanism consists of plungers actuated by a central fulcrum.

(2) Axle bearings are provided on the front trail to retain the axle when the piece is in the firing or towing positions. Various other brackets, bearings, and fittings are attached to the front and rear trails for accommodation of the elevating mechanism, equilibrators, etc.

(3) The rear trail is similar to the front trail in construction. It is fitted with a spade and handspike socket at the rear.

b. Removal and Disassembly.

(1) Removal of front and rear trail is outlined in TM 9-319 and TM 9-320.

(2) Disassembly of trail connecting mechanism is also covered in TM 9-319.

c. Repairs.

(1) Clean all parts of front and rear trails thoroughly.

(2) Examine carefully for cracks, wear, or breakage.

(3) Replace all worn or damaged parts.

d. Installation. Procedure for assembling trail connecting mechanism is outlined in TM 9-319, as is procedure for connecting the two trails.

32. WHEELS AND TIRES.

a. General.

(1) M1 CARRIAGE WHEELS (fig. 92).

(a) The M1 Carriages are fitted with artillery type wooden wheels with steel tires. These wheels are secured to the axle arms by means of lynch pins.

(b) Each wheel assembly is fitted with a hub liner, drag link, wheel ring, and wheel nut.

(c) The hub liners are keyed to the axle arms, and the wheels rotate on the hub liners.

MAINTENANCE OF PACK HOWITZER CARRIAGES M1 AND M8

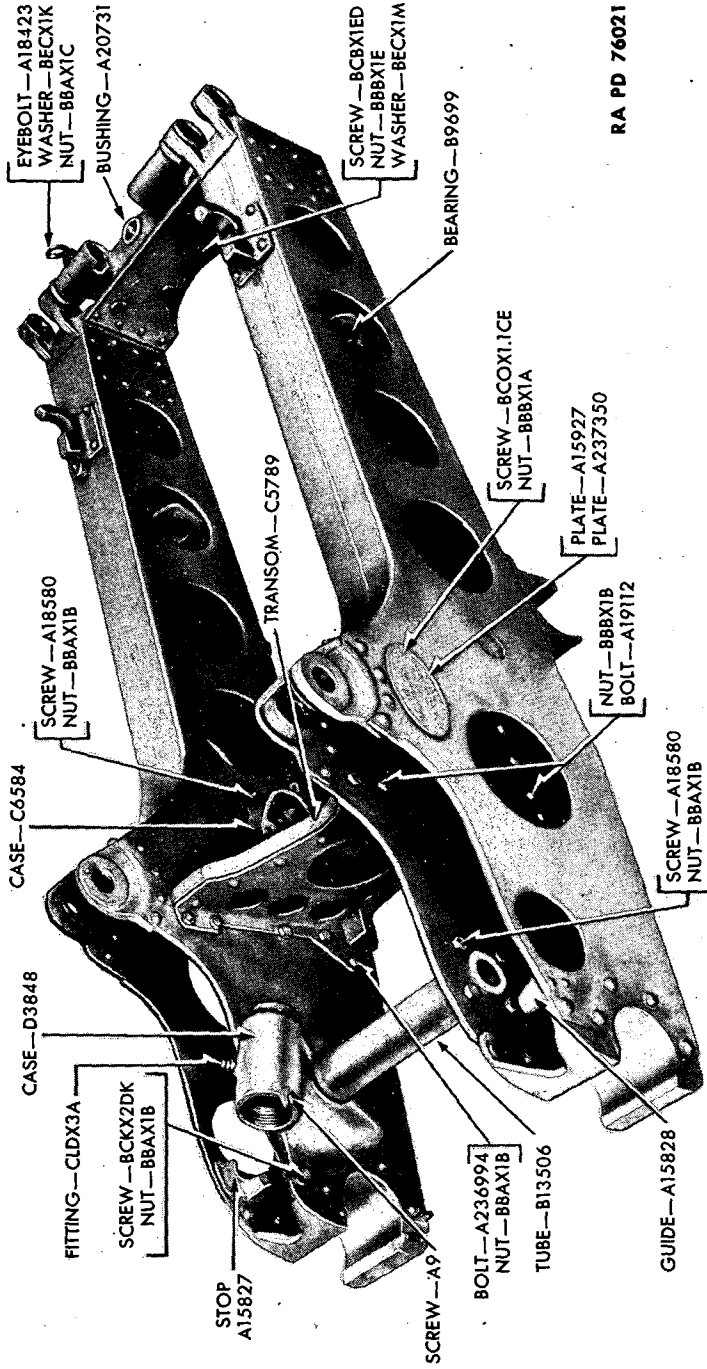

RA PD 76021

Figure 89—Front Trail Assembly

ORDNANCE MAINTENANCE
75-MM HOWITZERS AND CARRIAGES

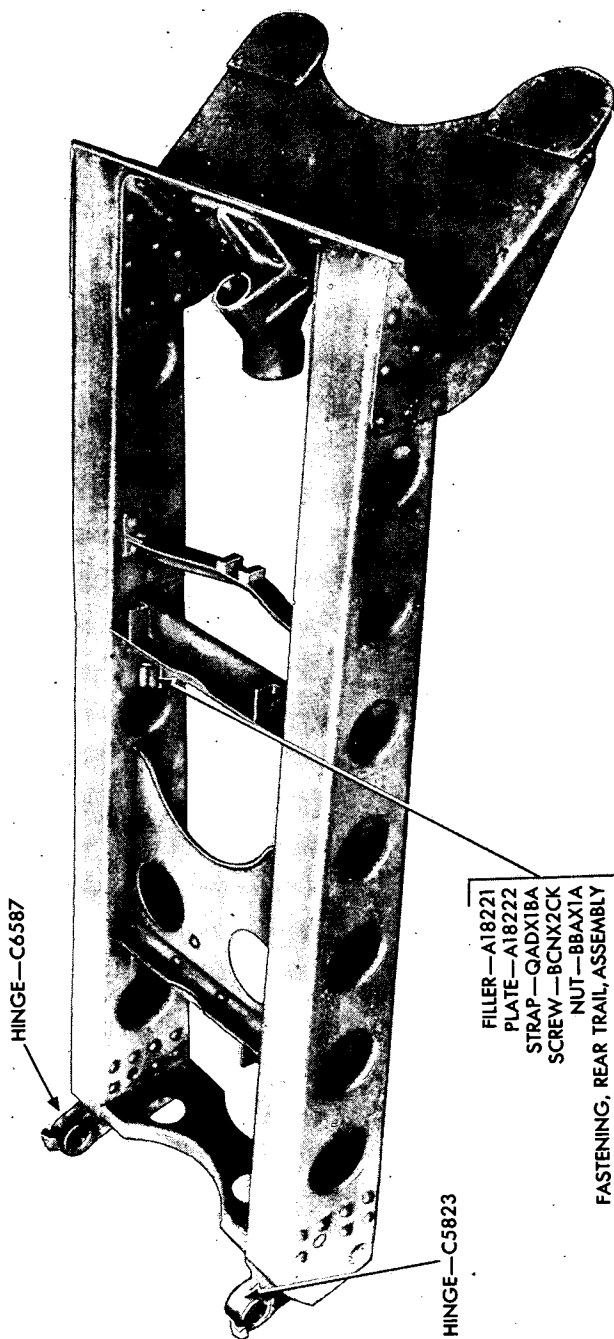

Figure 90—Rear Trail Assembly

MAINTENANCE OF PACK HOWITZER CARRIAGES M1 AND M8

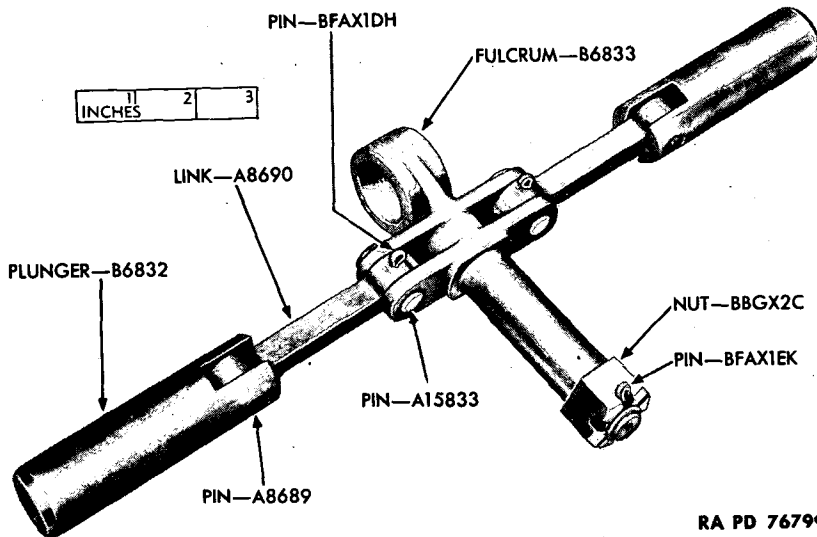

Figure 91—Trail Connecting Mechanism

(2) M8 CARRIAGE WHEELS (fig. 93).

(a) The M8 Carriages are fitted with wheels of the steel disk and rim type, equipped with 6.00 x 16 pneumatic tires.

(b) Each wheel consists of hub, disk and rim, balloon pneumatic tire, heavy-duty inner tube, and a tire locking ring.

(c) The hub liners are keyed to the axle arms, and the wheels rotate on the hub liners and roller bearings. The wheels are secured to the axle arms by linchpins.

b. Removal and Disassembly.

(1) Removal of wheels from carriage is covered in TM 9-319 and TM 9-320.

(2) DISASSEMBLY OF M1 CARRIAGE WHEEL.

(a) Remove screw from wheel nut and hub liner.

(b) Then unscrew and remove wheel nut from hub liner, using wheel nut spanner wrench B103690 (fig. 94).

(c) Drive hub liner out of wheel, using hub liner driving tool B104025 (fig. 30), if necessary.

(d) Remove screw from wheel ring and unscrew wheel ring from hub ring. Slide drag link off hub ring (fig. 92).

ORDNANCE MAINTENANCE
75-MM HOWITZERS AND CARRIAGES

RA PD 76800

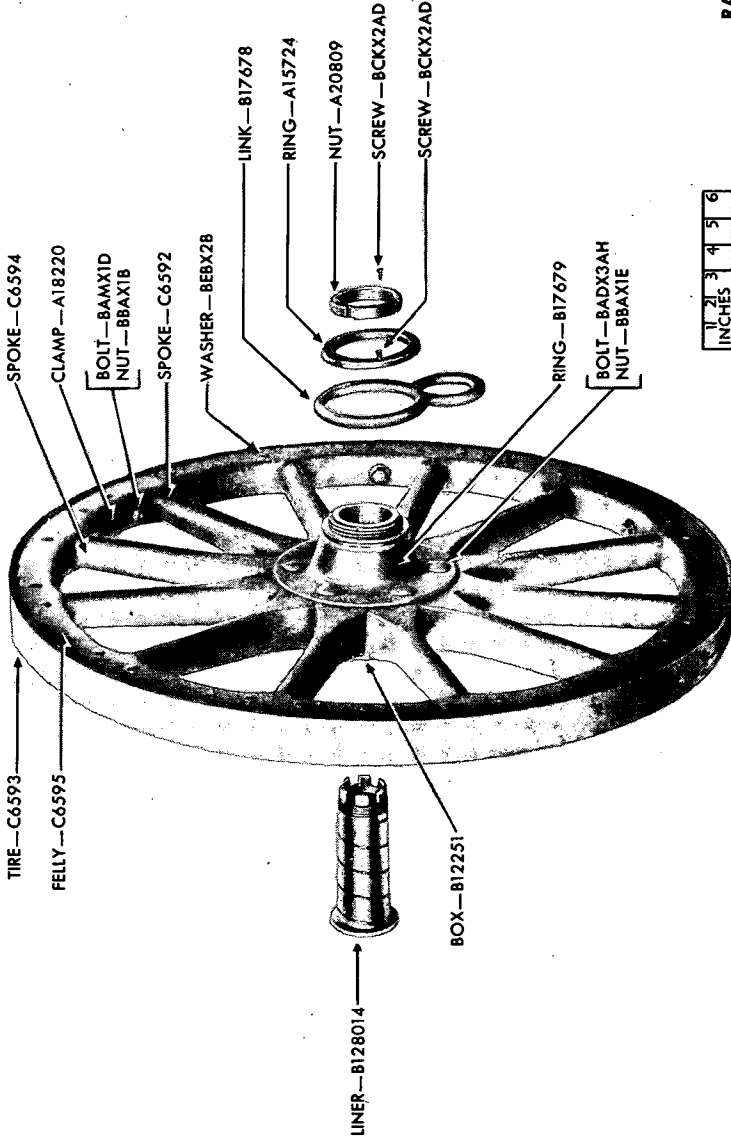
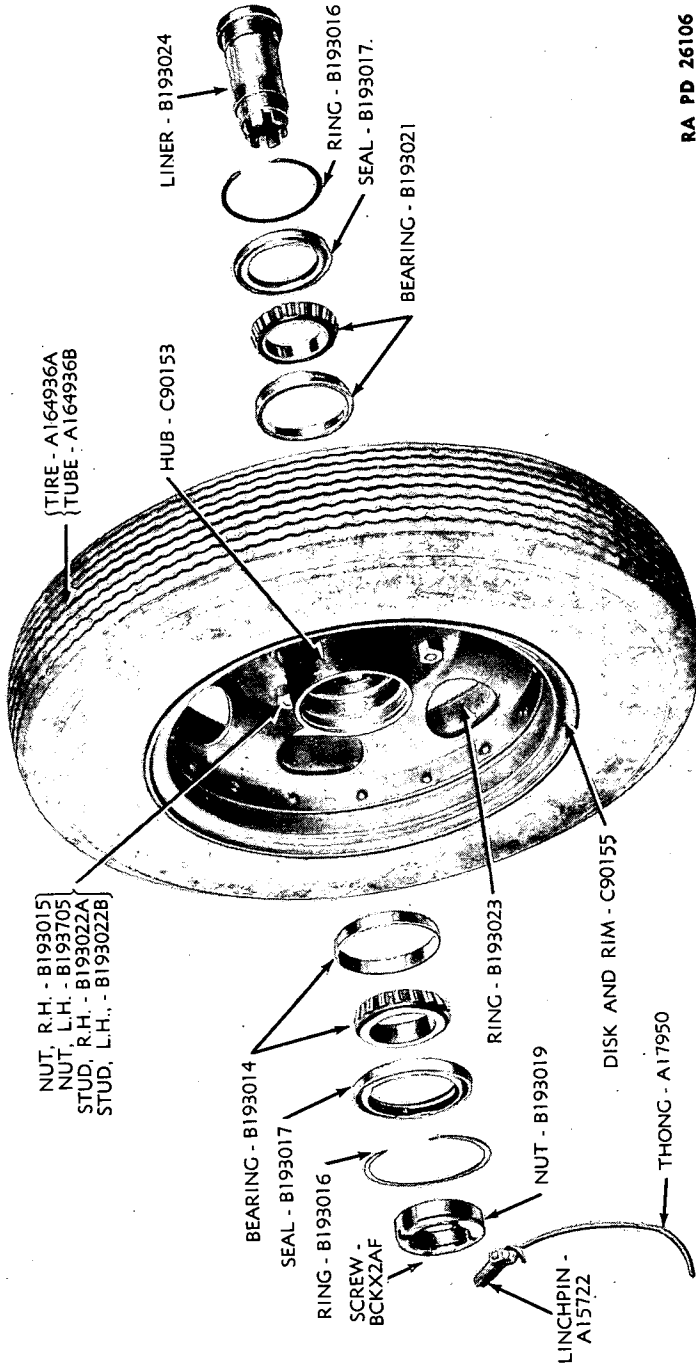

Figure 92—M1 Carriage Wheel Group

MAINTENANCE OF PACK HOWITZER CARRIAGES M1 AND M8



RA PD 26106

Figure 93—M8 Carriage Wheel Group

ORDNANCE MAINTENANCE
75-MM HOWITZERS AND CARRIAGES

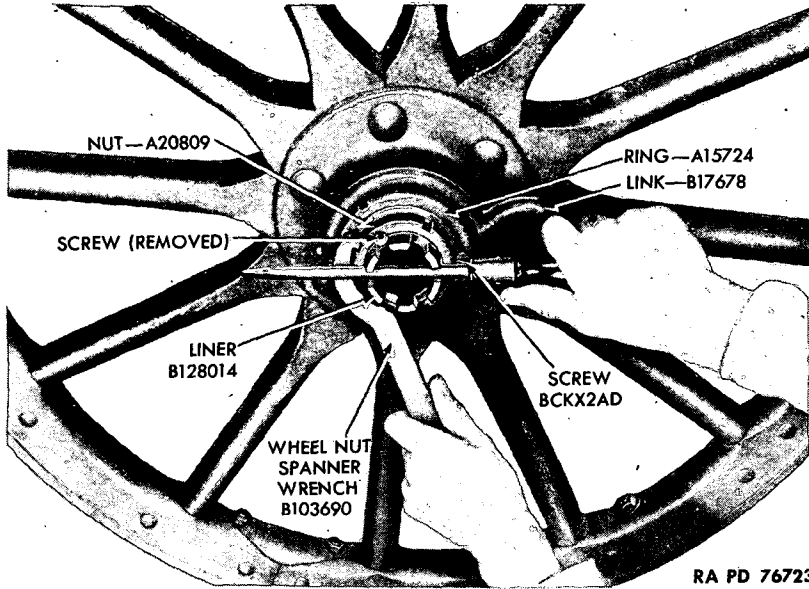

RA PD 76723

Figure 94—Removing Wheel Nut

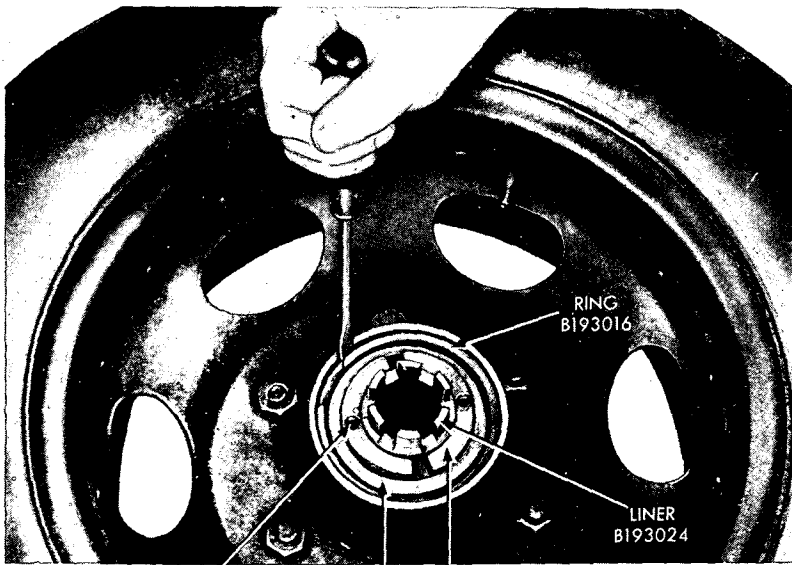

SCREW-BCKX2AF (REMOVED) SEAL-B193017 NUT-B193019

RA PD 76034

Figure 95—Removing Wheel Hub Liner

MAINTENANCE OF PACK HOWITZER CARRIAGES M1 AND M8**(3) DISASSEMBLY OF M8 CARRIAGE WHEEL.**

(a) Remove the two screws from wheel hub roller bearing lock nut (fig. 95).

(b) Using screwdriver as a pry, remove the snap ring.

(c) Unscrew and remove wheel hub roller bearing lock nut from hub liner, and tap hub liner out of wheel. Remove front oil seal, and cone and roller of front (outside) roller bearing (fig. 93).

(d) Remove rear snap ring, oil seal, and cone and roller of rear (inside) roller bearing. Outer races of both bearings can be driven out with a long drift and hammer (fig. 93).

c. Repairs.

(1) Clean all parts thoroughly.

(2) Examine all parts carefully for cracks, wear, or breakage.

(3) Replace all worn or damaged parts.

d. Assembly and Installation.**(1) ASSEMBLY OF M1 CARRIAGE WHEEL.**

(a) Tap the hub liner into place in the hub ring. Place the drag link in position on the outside of the wheel, and screw the wheel ring on the hub ring. Secure with set screw.

(b) Screw the wheel nut on the hub liner using wheel nut spanner wrench B103690 (fig. 94). Secure with set screw.

(2) ASSEMBLY OF M8 CARRIAGE WHEEL.

(a) If the roller bearing outer races (cups) have been removed from the wheel hub, drive them into place with a brass drift and a hammer.

(b) Place the rear cone and roller, oil seal, and snap ring in place in rear of wheel hub. Then insert the hub liner.

(c) Place the front or outside cone and roller in place on hub liner and in wheel hub; follow with oil seal and snap ring. Then screw the roller bearing lock nut B193019 on the wheel hub liner B193024. Adjust wheel bearings by tightening the nut until the wheel bearings bind, then back off until wheel rotates freely and without end play. Secure nut with two screws. Always pack the wheel bearings with grease before installation (section X).

(3) **INSTALLATION OF WHEELS.** Installation of M1 and M8 Carriage wheels are covered in TM 9-319 and TM 9-320.

**ORDNANCE MAINTENANCE
75-MM HOWITZERS AND CARRIAGES****Section IX****MAINTENANCE OF FIELD HOWITZER
CARRIAGE M3A3****33. GENERAL.**

a. The 75-mm Howitzer Carriage M3A3 is the present standard field howitzer designed especially for high speed travel (fig. 96). This carriage is a split trail type vehicle equipped with standard commercial automobile brakes. Pneumatic tires of the combat type with divided rims are used instead of the standard commercial pneumatic tire with disk and rim wheels (par. 2). The wheels are mounted on antifriction bearings. Wheel carriers support the wheels when the carriage is in the traveling position. Pintle traverse is used.

b. The top and bottom sleighs are identical with those used on the 75-mm Pack Howitzer Carriages M1 and M8. The cradle is practically the same as the cradle of the M1 and M8 Pack Howitzer Carriages, except that it is fitted with two sight brackets instead of one; the elevating arc is attached to it; and near the front of the under side is located the cradle lock pin, cradle lock pin handle, and turnbuckle. This provides a means of locking firing base to the cradle when the carriage is in the traveling position. The four cradle locking pins of the M1 and M8 Cradle are eliminated. The M3A3 Carriage Cradle is fitted at the rear with brackets or lugs for attaching the cradle to the top carriage with trunnion pins.

c. In the following paragraphs the carriage is entirely disassembled into its major components in the logical order of disassembly. Each major unit is described and proper procedures for maintenance and repair are prescribed. Removal of the top sleigh, tube, and bottom sleigh is described in paragraphs 20, 26, and 24.

34. SHIELD.

a. The shield assembly used on the M3A3 Carriage is composed of four sections of armor plate (fig. 97). The right and left bodies of the shield are joined together at the top by a steel plate in the front and a steel piece in the rear. The left and right wings are fastened to their respective shield sections by means of four heavy hinges. Two shield latches fitted with turnbuckles support the wing sections in the open and closed positions. Shield braces are provided for mounting the shield assembly on the top carriage (fig. 98).

b. Removal and Disassembly.

- (1) Place the howitzer tube in a level position.
- (2) Place the shield wings in the open or firing position.

MAINTENANCE OF FIELD HOWITZER CARRIAGE M3A3

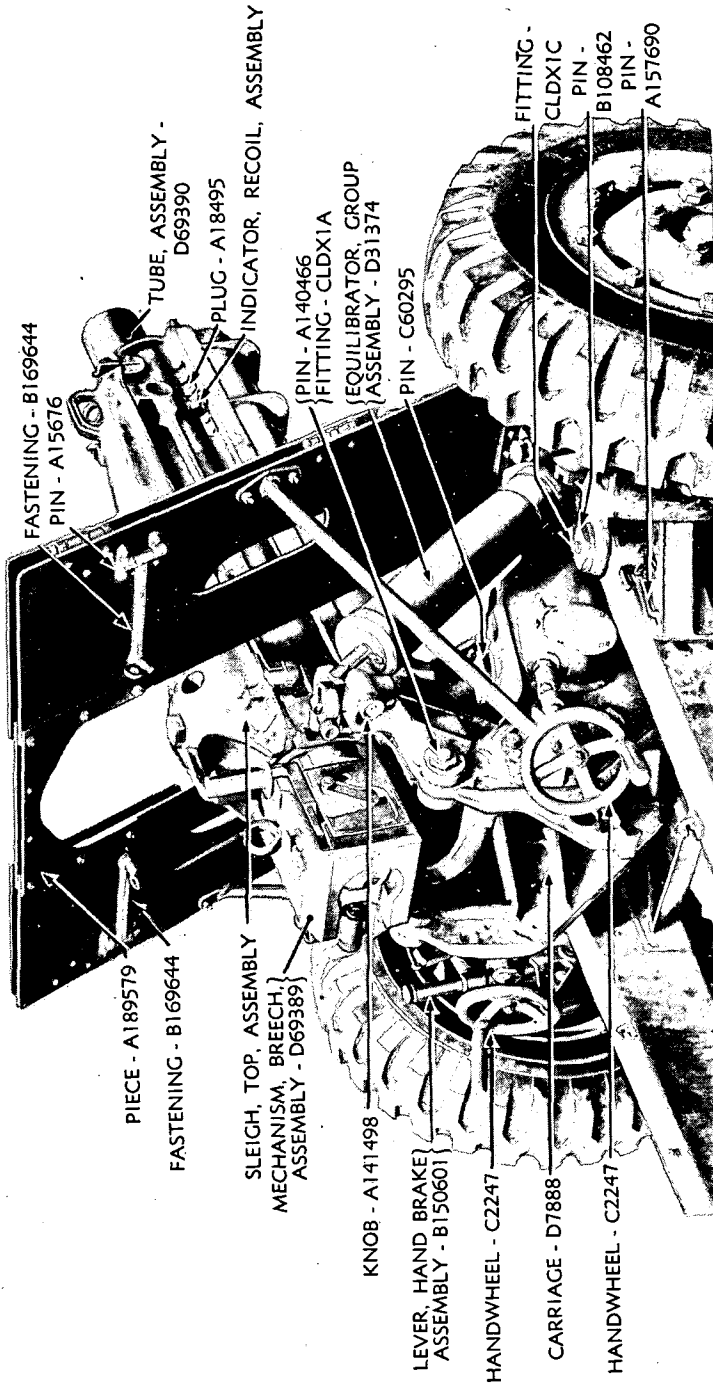

RA PD 26123

Figure 96—75-mm Howitzer M1A1 and Carriage M3A3

ORDNANCE MAINTENANCE
75-MM HOWITZERS AND CARRIAGES

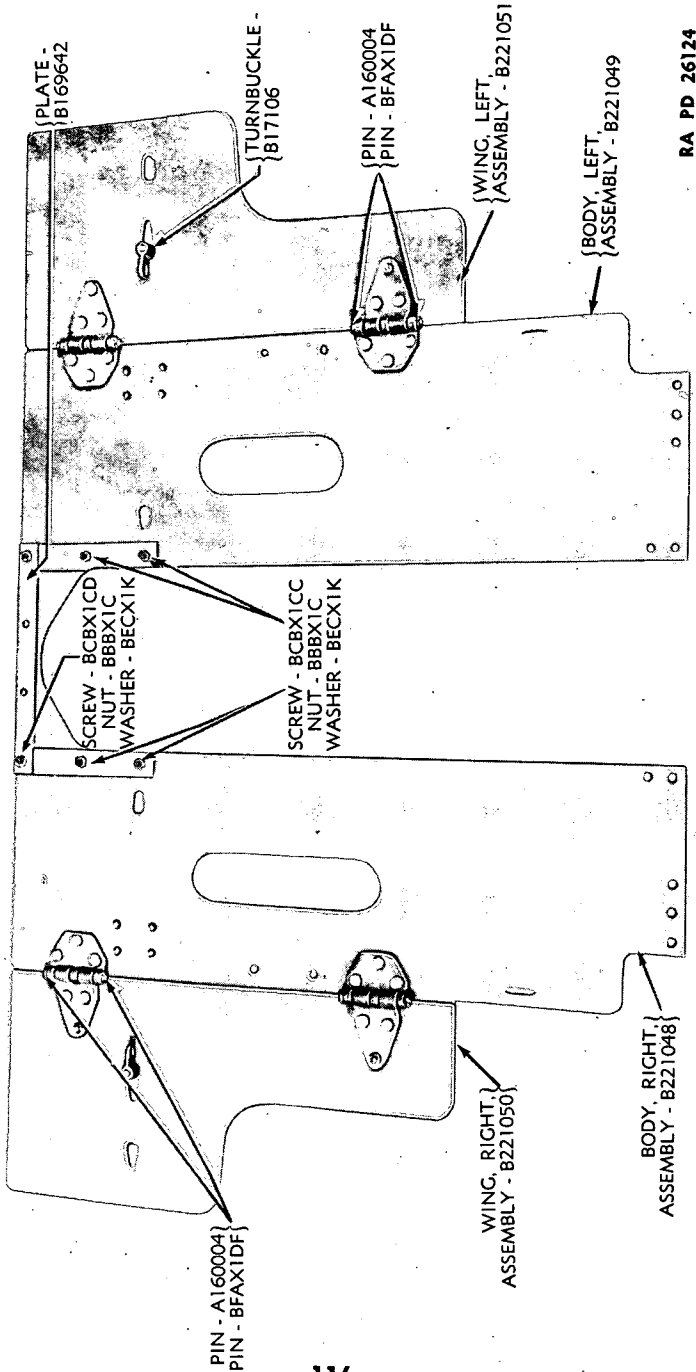

RA PD 26124

Figure 97—Shield Assembly

MAINTENANCE OF FIELD HOWITZER CARRIAGE M3A3

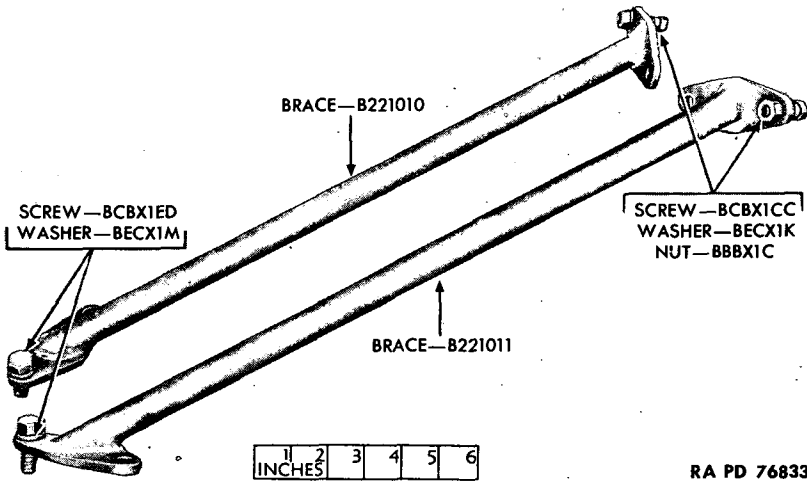

RA PD 76833

Figure 98—Shield Braces

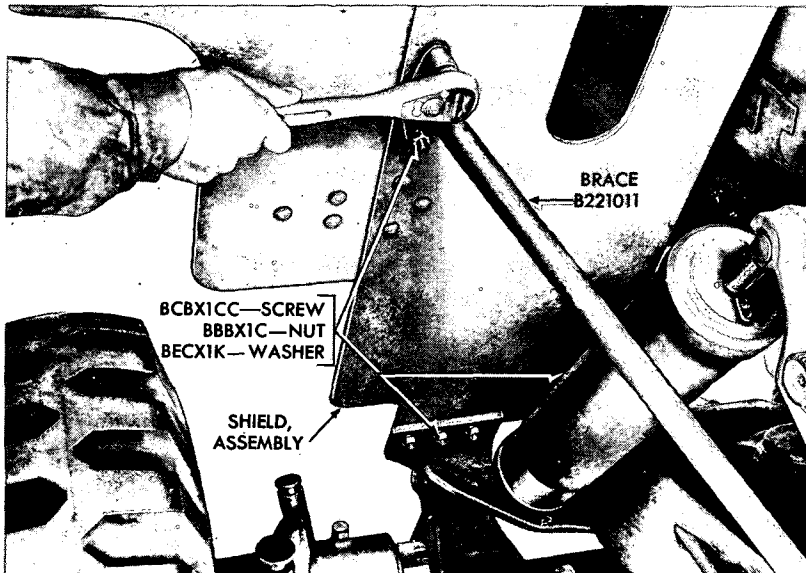

RA PD 77056

Figure 99—Removing Shield

(3) Loosen and remove the 10 screws, washers, and nuts that fasten shield to top carriage and to shield braces (fig. 99). Remove shield (two men).

(4) Remove the four screws and washers that are used to fasten the right and left shield braces to the top carriage. Mark the shield

**ORDNANCE MAINTENANCE
75-MM HOWITZERS AND CARRIAGES**

braces "right" and "left" so that they can be easily identified when shield is mounted on top carriage.

c. **Repairs.** Examine the shield for damage and for broken or loose rivets and screws. Replace worn or damaged parts with new parts. Open and close the right and left shield wings, and check hinges and latches. Make necessary adjustments and replacements. Tighten all loose screws.

d. **Assembly and Installation.**

(1) Place the right and left shield braces in position on the top carriage and secure each shield brace with two screws and washers.

(2) With two men lifting the shield into place, secure the shield to the top carriage and to the shield braces with ten screws, washers, and nuts. *NOTE: All screws are put in from the front of the shield.*

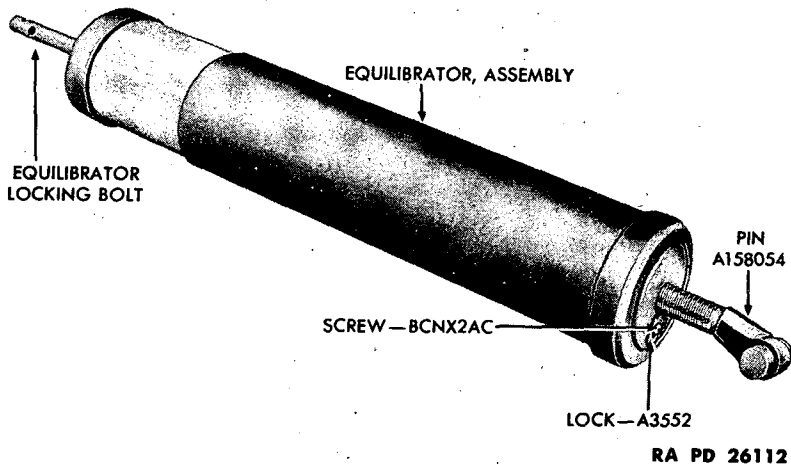

Figure 100—Equilibrator Assembly

35. EQUILIBRATORS.

a. Two enclosed spring type equilibrators are provided to overcome the preponderance of muzzle weight, resulting from the position of the cradle trunnions so far to the rear of the center of gravity of the tipping parts (fig. 96).

(1) The high speed field howitzer equilibrator is practically the same in design and construction as the M1 and M8 Carriage Equilibrator, excepting that it is enclosed in a cylinder assembly (fig. 100).

(2) The M3A3 Carriage Equilibrator is composed of the equilibrator spring, equilibrator barrel, equilibrator cylinder assembly,

MAINTENANCE OF FIELD HOWITZER CARRIAGE M3A3

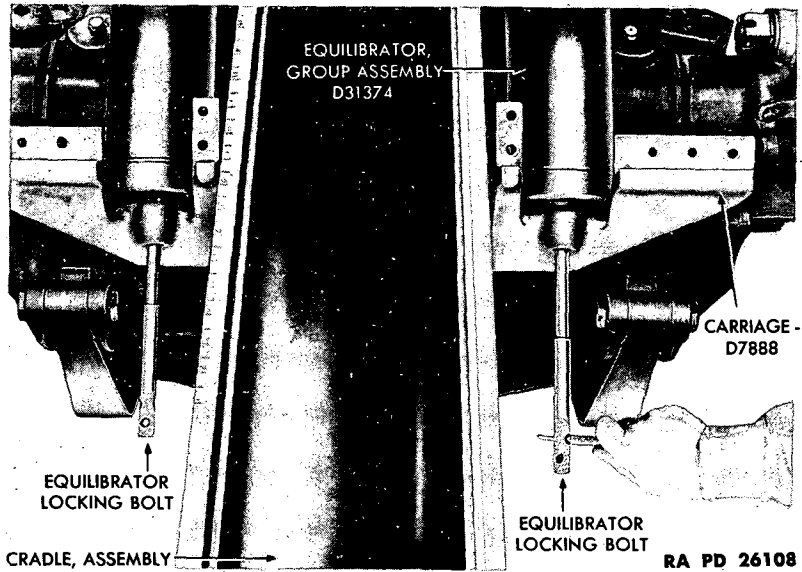

Figure 101—Installing Equilibrator Locking Bolt

equilibrator trunnion pin lock, and equilibrator trunnion pin (bent design) (fig. 104).

(3) The equilibrator spring pressure is adjustable within limits to obtain the lightest and most uniform resistance to elevation and depression. This adjustment is obtained by screwing the trunnion pins in or out as the case may be.

(4) The front or lower end of the equilibrator is designed to receive the equilibrator locking bolt (fig. 31). This bolt is a tool used to hold the equilibrator spring in the compressed position while the equilibrator is being removed or installed (fig. 101).

b. Removal and Disassembly.

(1) REMOVAL FROM CARRIAGE.

(a) Elevate the howitzer to zero elevation.

(b) Remove shield, top sleigh, howitzer tube, breech mechanism, and bottom sleigh. *NOTE: It is not necessary to remove any of the above if one equilibrator only is being removed, or if the carriage is not to be disassembled.*

(c) Insert the equilibrator assembling or locking bolt through the opening in the cup-shaped bearing of the top carriage and through the equilibrator barrel (fig. 101).

**ORDNANCE MAINTENANCE
75-MM HOWITZERS AND CARRIAGES**

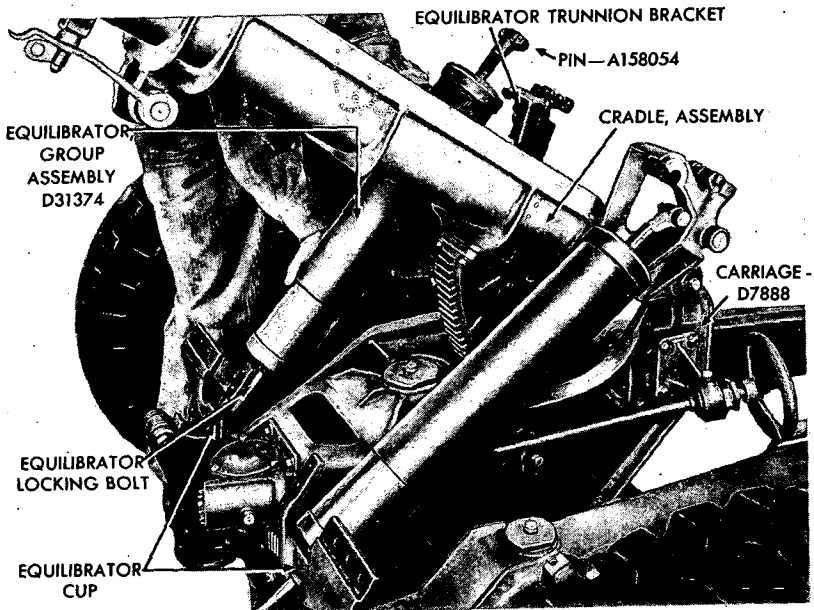

RA PD 26107

Figure 102—Removing Equilibrator

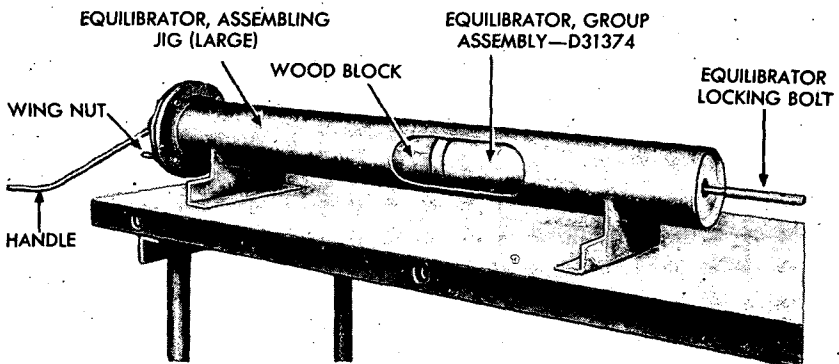

RA PD 26135

Figure 103—Disassembling M3A3 Carriage Equilibrator

(d) Advance the bolt until it comes in contact with the equilibrator spring guide tube plug. Screw the bolt into the plug as far as it will go.

(e) Elevate the cradle until the equilibrator trunnion pins are free from their brackets, and remove the equilibrators (fig. 102). Support the equilibrators while the cradle is being elevated, as they may drop and damage the trunnion pins.

MAINTENANCE OF FIELD HOWITZER CARRIAGE M3A3

RA PD 76819

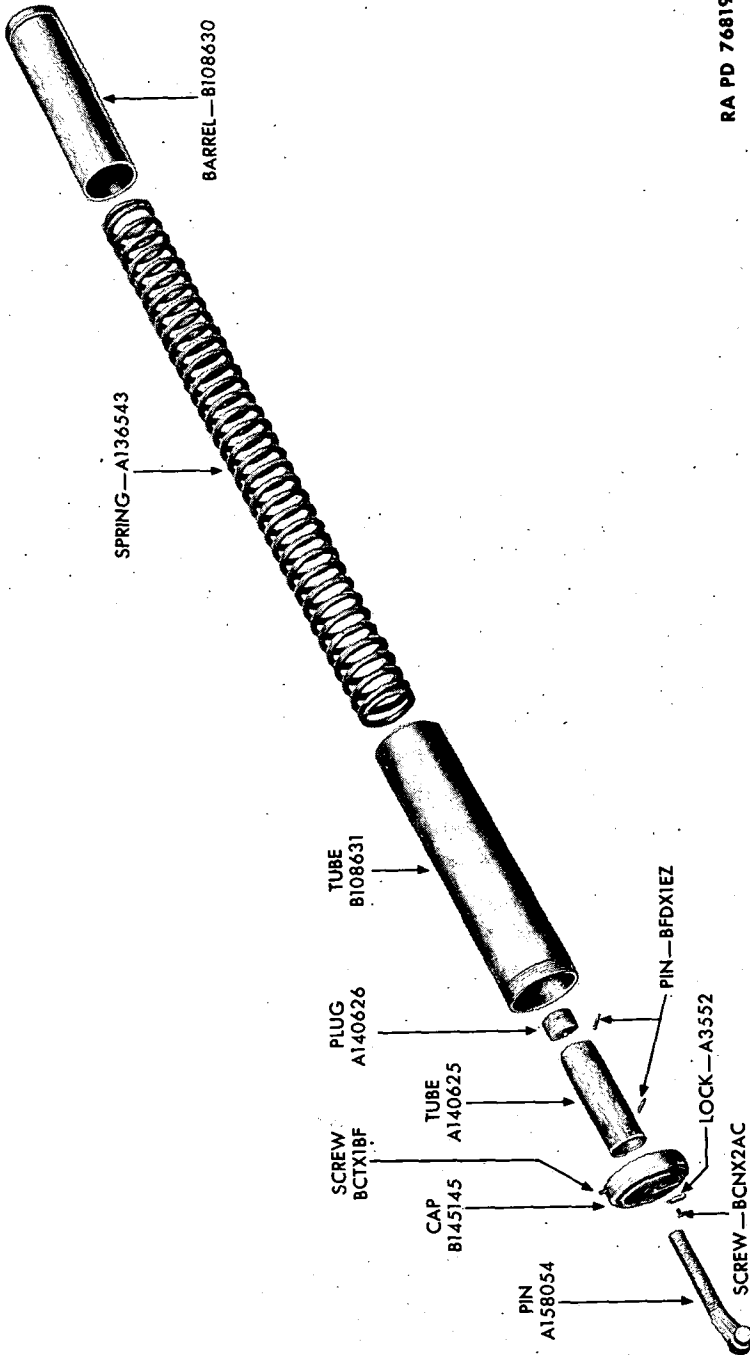

Figure 104—M3A3 Equilibrator—Exploded View

ORDNANCE MAINTENANCE 75-MM HOWITZERS AND CARRIAGES

(2) DISASSEMBLY OF EQUILIBRATOR.

(a) Remove screw and equilibrator trunnion pin lock. Then unscrew and remove the equilibrator trunnion pin.

(b) Place remainder of the unit in equilibrator assembling jig (large size) (figs. 32 and 103) with locking bolt protruding through rear of jig.

(c) Tighten front cover and screw handle in position; and by turning handle on jig screw, remove the tension from the equilibrator locking bolt. *NOTE: It may be necessary to insert a wooden block (6 in. long with a 4½-in. diam) between equilibrator cap and jig screw in order to disassemble equilibrator (fig. 103).*

(d) Remove equilibrator locking bolt (tool), back off on jig screw, remove front cover of jig and equilibrator parts.

(e) Remove screw and unscrew equilibrator cap from equilibrator cylinder tube B108631 (fig. 104).

(f) To remove equilibrator spring guide tube A140625 and plug from equilibrator cap, drive out the two straight pins and unscrew plug and tube (fig. 104).

c. Repairs.

(1) Clean all parts of the equilibrator thoroughly.

(2) Examine all parts carefully for cracks, wear, or breakage.

(3) Replace all worn or damaged parts.

d. Assembly and Installation.

(1) ASSEMBLY OF EQUILIBRATOR.

(a) If removed, screw the spring guide tube in place in the equilibrator cap. Secure with straight pin. Install plug in tube in same manner (fig. 104).

(b) Screw the cap assembly in place on the equilibrator cylinder tube B108631. Secure with socket-head set screw.

(c) Slide the equilibrator spring and barrel into place in the cylinder tube. Then insert this unit in the equilibrator assembling jig. Be sure to insert the barrel end of the equilibrator into the jig foremost.

(d) Put the front cover, jig screw, and wooden block (if needed) in place, and compress the equilibrator spring so that the equilibrator locking bolt (tool) can be screwed into the equilibrator plug (fig. 103).

(e) Screw the locking bolt in as far as it will go and remove the unit from the jig.

(f) Screw the trunnion pin in place in the equilibrator cap and secure with trunnion pin lock and screw. *NOTE: Adjustment of equilibrator is made after equilibrator is mounted on the carriage.*

MAINTENANCE OF FIELD HOWITZER CARRIAGE M3A3

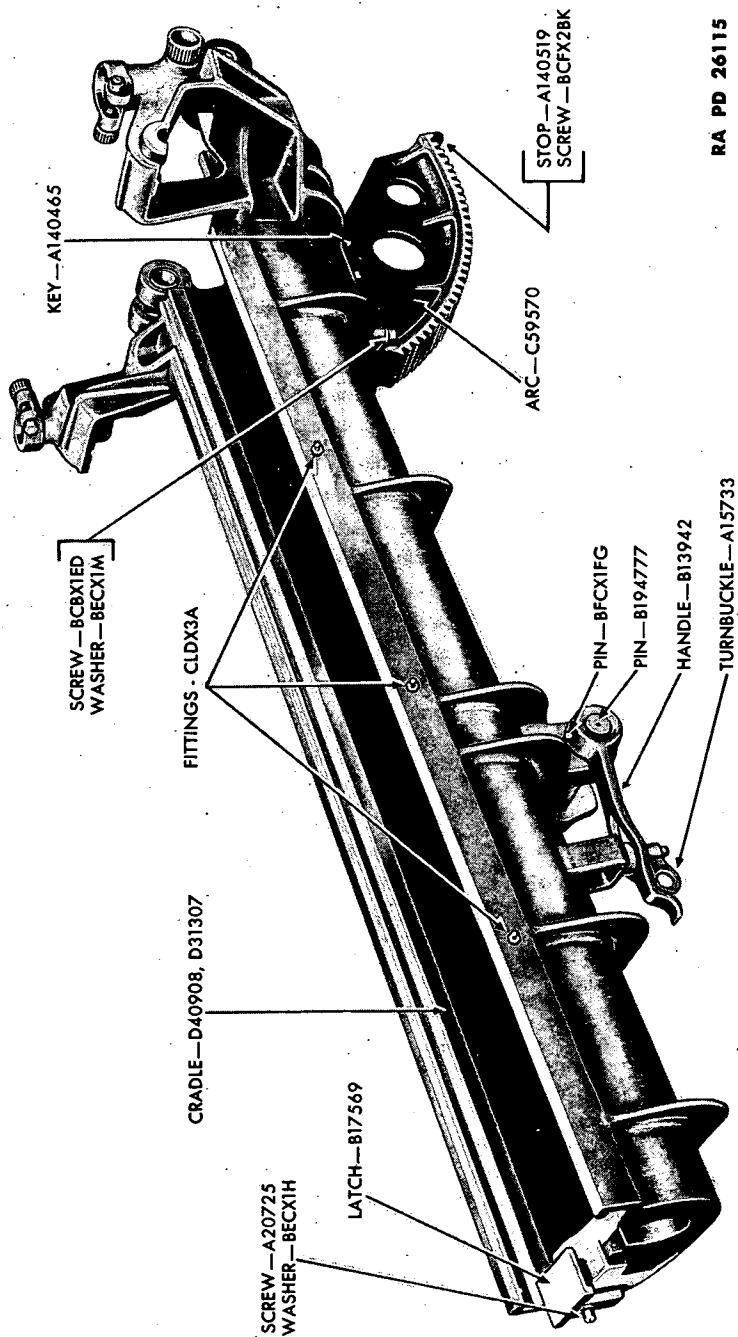

RA PD 26115

Figure 105—Cradle Assembly

**ORDNANCE MAINTENANCE
75-MM HOWITZERS AND CARRIAGES**

(2) INSTALLATION OF EQUILIBRATOR.

(a) Place the equilibrator barrel end in the cup bracket of the top carriage with the equilibrator locking bolt projecting down through the cup bracket (fig. 101).

(b) Hold the upper end of the equilibrator in position so that the equilibrator trunnion pin will seat in the trunnion pin notch of the cradle bracket when the cradle is depressed (fig. 102). The bent portion of the equilibrator trunnion pin should be pointing down.

(c) Depress the cradle, mount bottom sleigh, breech mechanism, howitzer tube, and top sleigh.

(d) Then adjust the equilibrators to provide desired ease of elevation and depression. This is done by screwing the trunnion pin in or out of the equilibrator.

(e) Mount shield, if removed (par. 34 d).

36. CRADLE.

a. Complete description of the cradle is contained in paragraphs 27 a and 33 b (fig. 105).

b. Removal and Disassembly.

(1) REMOVAL OF CRADLE.

(a) Remove shield (par. 34 h).

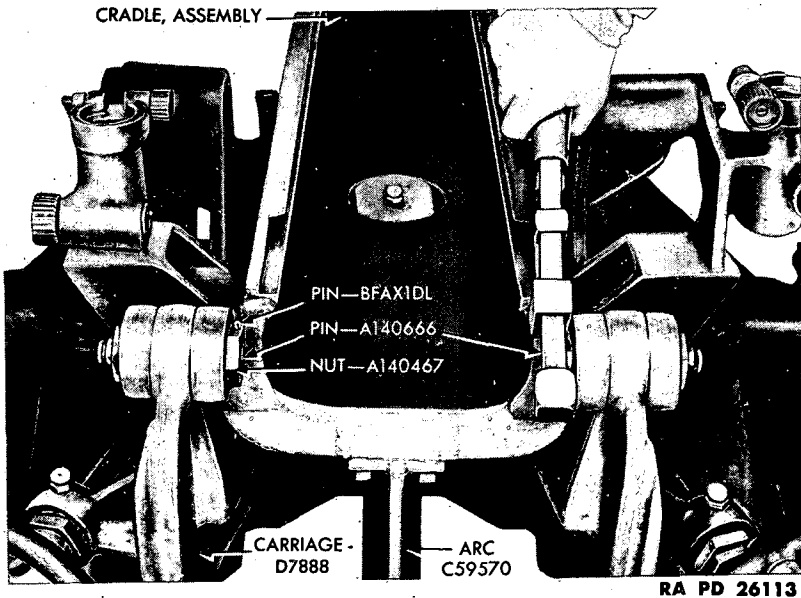

Figure 106—Removing Cradle

MAINTENANCE OF FIELD HOWITZER CARRIAGE M3A3

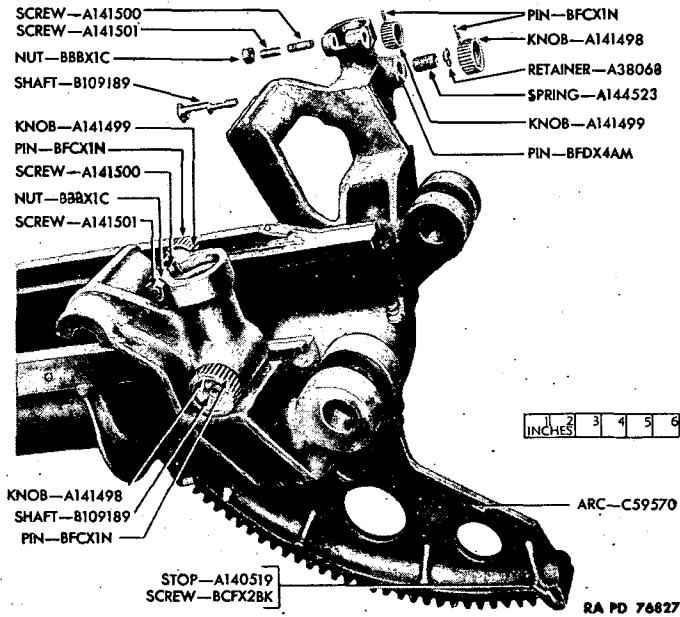

Figure 107—Sight Bracket Mechanism

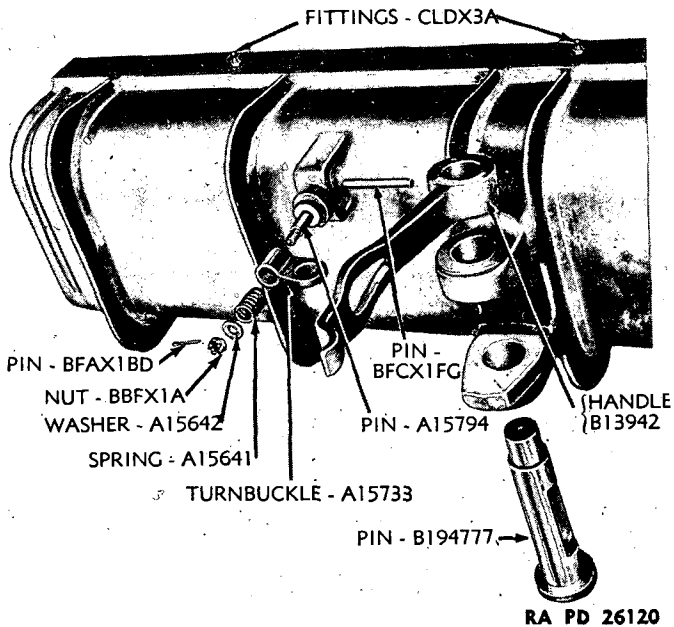
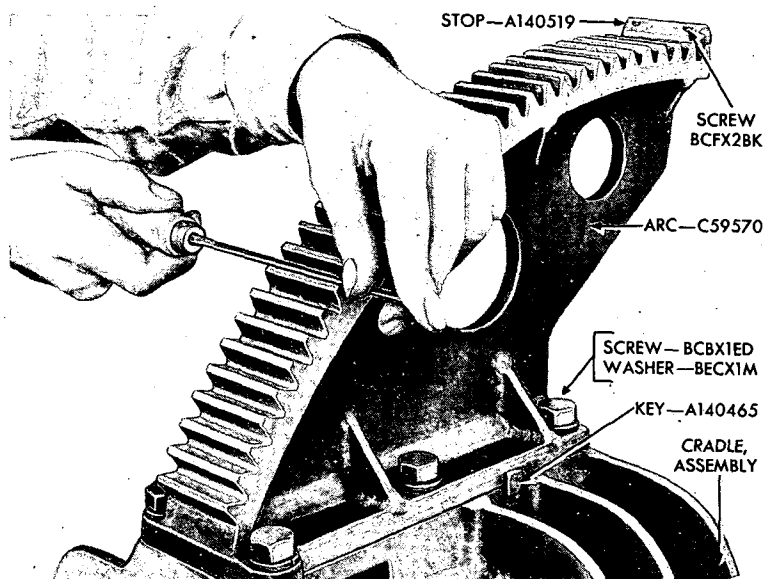

Figure 108—Cradle Lock—Exploded View

ORDNANCE MAINTENANCE 75-MM HOWITZERS AND CARRIAGES



RA PD 77054

Figure 109—Repairing Elevating Arc

(b) Remove top sleigh, howitzer tube, breech mechanism, bottom sleigh, and equilibrators (par. 35 b).

(c) Remove cotter pins and nuts from both cradle trunnion pins (fig. 106). Tap trunnion pins out and lift cradle off.

(2) **DISASSEMBLY OF CRADLE.**

(a) Disassembly of piston rod latch and sight bracket mechanism is covered in paragraph 27 b. *NOTE: There are two sight bracket groups on the M3A3 Carriage.* The procedure of disassembly is the same (fig. 107).

(b) To disassemble cradle lock, drive straight pin out of cradle lock pin handle and cradle lock pin. Remove handle from pin and push cradle lock pin out of cradle (fig. 108).

(c) To remove turnbuckle, remove cotter pin, unscrew nut BBFX1A, and remove nut and washer A15642. Remove spring and turnbuckle (fig. 108).

c. Repairs.

- (1) Clean all parts of the cradle thoroughly.
- (2) Examine all parts carefully for cracks, wear, or breakage.
- (3) Replace all worn or damaged parts.
- (4) **REPAIRING ELEVATING ARC TEETH** (fig. 109).

MAINTENANCE OF FIELD HOWITZER CARRIAGE M3A3

(a) Remove burrs or nicks from elevating arc teeth, using a smooth file, and polish with crocus cloth.

(b) Remove only enough metal to remove burr and to restore tooth contour. Then clean thoroughly.

(5) **TO REPLACE DAMAGED ELEVATING ARC.**

CAUTION: It is important that the elevating arc not be removed from the cradle unless it is damaged, and it is necessary to replace it with a new arc. Since the elevating arc is a portion of a circle, with the center of the circle at the center of the trunnions, it is most important that when assembling a new arc, this alignment be obtained.

(a) Remove the six screws and washers that fasten the elevating arc to the cradle, with the cradle in the upside-down position (fig. 109).

(b) Tap the elevating arc from either side to loosen the arc from the key. Use a copper hammer. Then remove the key.

(c) Before the new arc is installed, fit the key to the arc and also to the key slot in the cradle. This key should be a snug fit in the keyways of the arc and cradle.

(d) Insert key into keyway in the cradle. Clean all contacting surfaces thoroughly. Tap the arc down on the key and in place on the cradle with the six holes lined up with the tapped holes in the cradle. Secure the arc with six washers and screws, making certain that the screws are all tightened down evenly. This may be accomplished by tightening the center screws until they are just snug, then tightening two rear screws the same as the two center screws. The two front screws are then tightened equal to the other four. This process is continued, tightening not more than a quarter turn on each screw until all screws are down sufficiently tight.

(e) If no jig is available to check the alignment of the arc, it will be necessary to assemble the cradle to the top carriage, and by elevating and depressing through the entire range, determine where the misalignment is located. If the elevating mechanism binds, the elevating arc is too far forward and must be moved toward the rear of the cradle. This is accomplished by removing the elevating arc, removing metal from the front surface of the keyway in the cradle, and adding shims of the same thickness as the metal removed to the rearward side of the key. Make certain that the key fits snugly in the keyway when this operation is performed. If there is excessive play between the elevating arc and the elevating pinion, it will be necessary to remove metal from the rear side of the keyway, and adding shims to the front side of the keyway. Care must be taken to insure that the screw holes in the elevating arc are in proper alignment with the tapped holes in the cradle. If the arc must be moved so that the holes are out of alignment, it will be necessary to remove metal from the holes in the elevating arc.

**ORDNANCE MAINTENANCE
75-MM HOWITZERS AND CARRIAGES**

d. Assembly and Installation.

(1) ASSEMBLE CRADLE LOCK.

(a) Place the turnbuckle and spring in place on the pin A15794 (fig. 108). Then follow with the washer A15642 and nut BBFX1A. Secure nut to pin with cotter pin.

(b) Slide the cradle lock pin in place in the cradle from the right side of cradle. Tap the cradle lock pin handle in place and secure with the straight pin (fig. 108).

(2) ASSEMBLE SIGHT BRACKET AND PISTON ROD LATCH. These are covered in paragraph 27 d.

(3) INSTALLATION.

(a) Place the cradle in position on the top carriage.

(b) Slide or tap the cradle trunnion pins into place. These pins go in from the outside with nuts on the inside (fig. 106). Screw the nuts on the trunnion pins and secure with cotter pins.

(c) Replace equilibrators (par. 35 d).

(d) Replace bottom sleigh, howitzer tube, breech mechanism, and top sleigh TM 9-320.

(e) Replace shield (par. 34 d).

37. TRAVERSING MECHANISM.

a. General.

(1) The M3A3 Carriage has pintle traverse. The top carriage is traversed in the desired direction by means of the traversing handwheel located on the left side of the top carriage (figs. 73 and 110). The handwheel is mounted on a shaft that connects with a traversing gear case mounted at the front of the top carriage (fig. 111). In this gear case are a worm, worm wheel, and pinion. The pinion meshes with a traversing rack attached to the front of the bottom carriage (fig. 112). Stops are provided at each end of the traversing rack to limit maximum traverse (fig. 110). The rotating parts are mounted on oil-sealed antifriction bearings.

(2) The entire traversing mechanism can be removed from the top carriage without disturbing any other part of the carriage.

b. Removal and Disassembly.

(1) REMOVAL.

(a) Remove the cotter pin from the traversing handwheel shaft and rear half of flexible joint (fig. 111). Then pull the handwheel and shaft back out through the handwheel shaft bracket. *NOTE: The flexible joint will remain on the traversing worm shaft.*

MAINTENANCE OF FIELD HOWITZER CARRIAGE M3A3

RA PD 76836

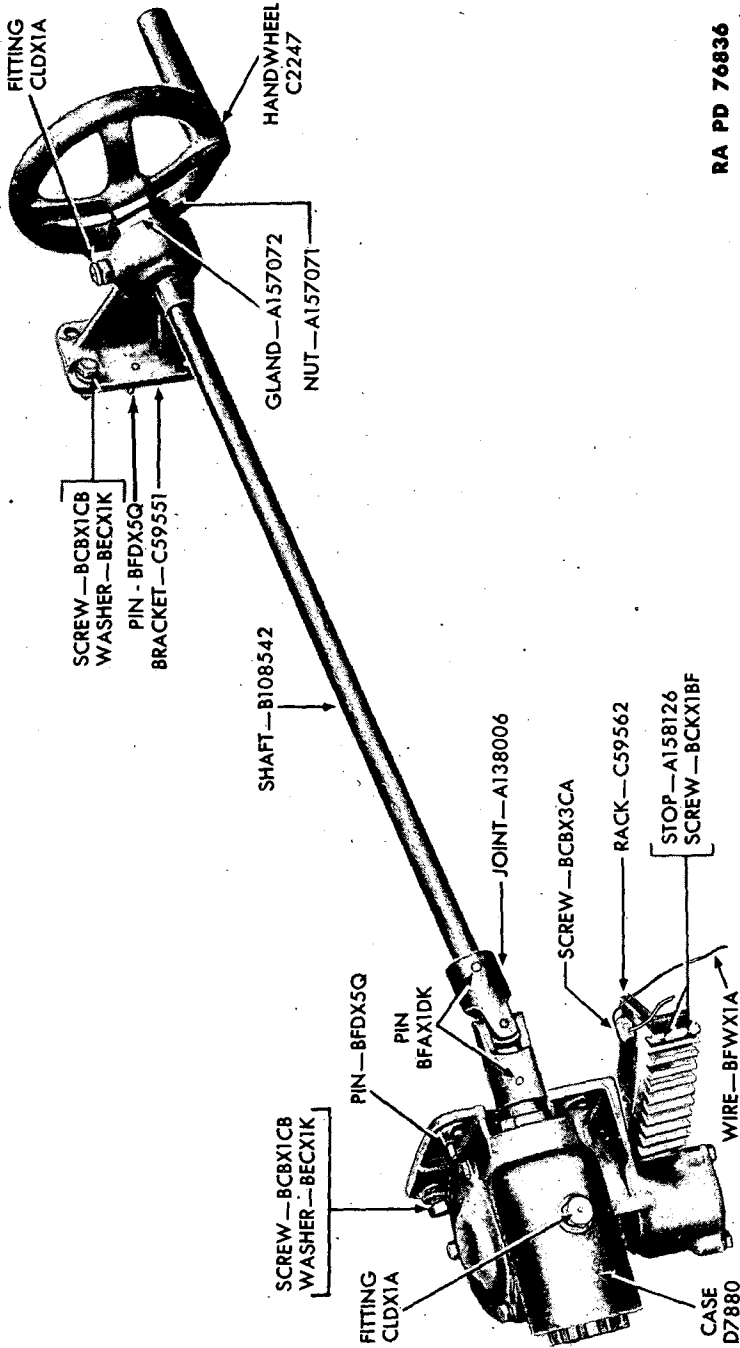

Figure 110—Traversing Mechanism Arrangement

**ORDNANCE MAINTENANCE
75-MM HOWITZERS AND CARRIAGES**

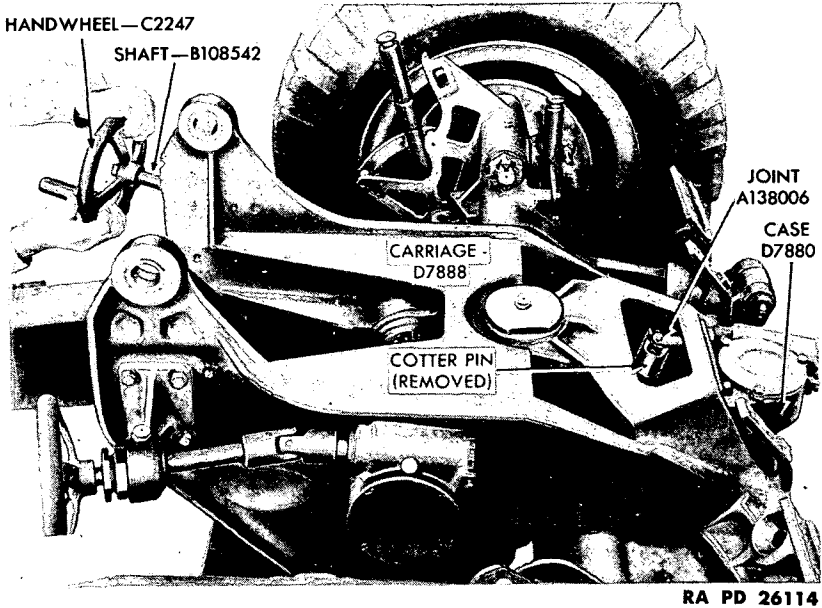

Figure 111—Removing Traversing Handwheel Shaft

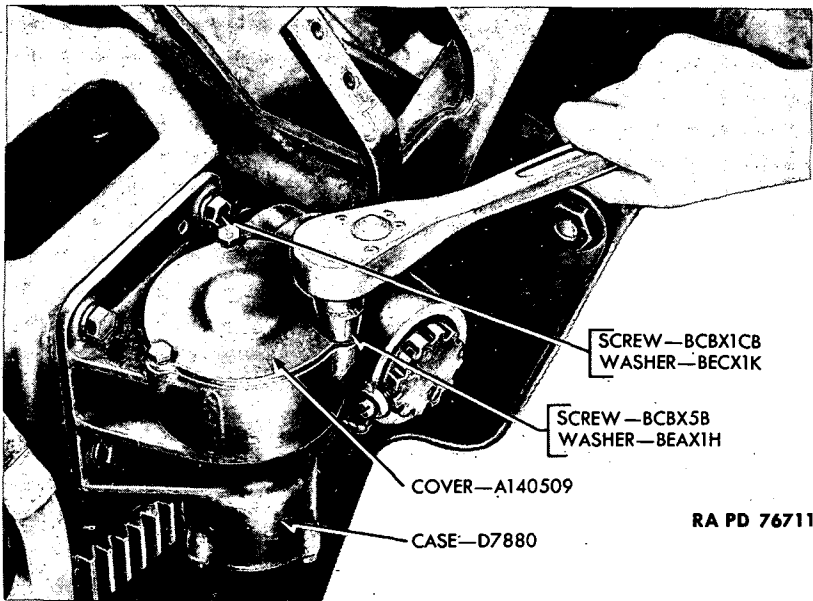
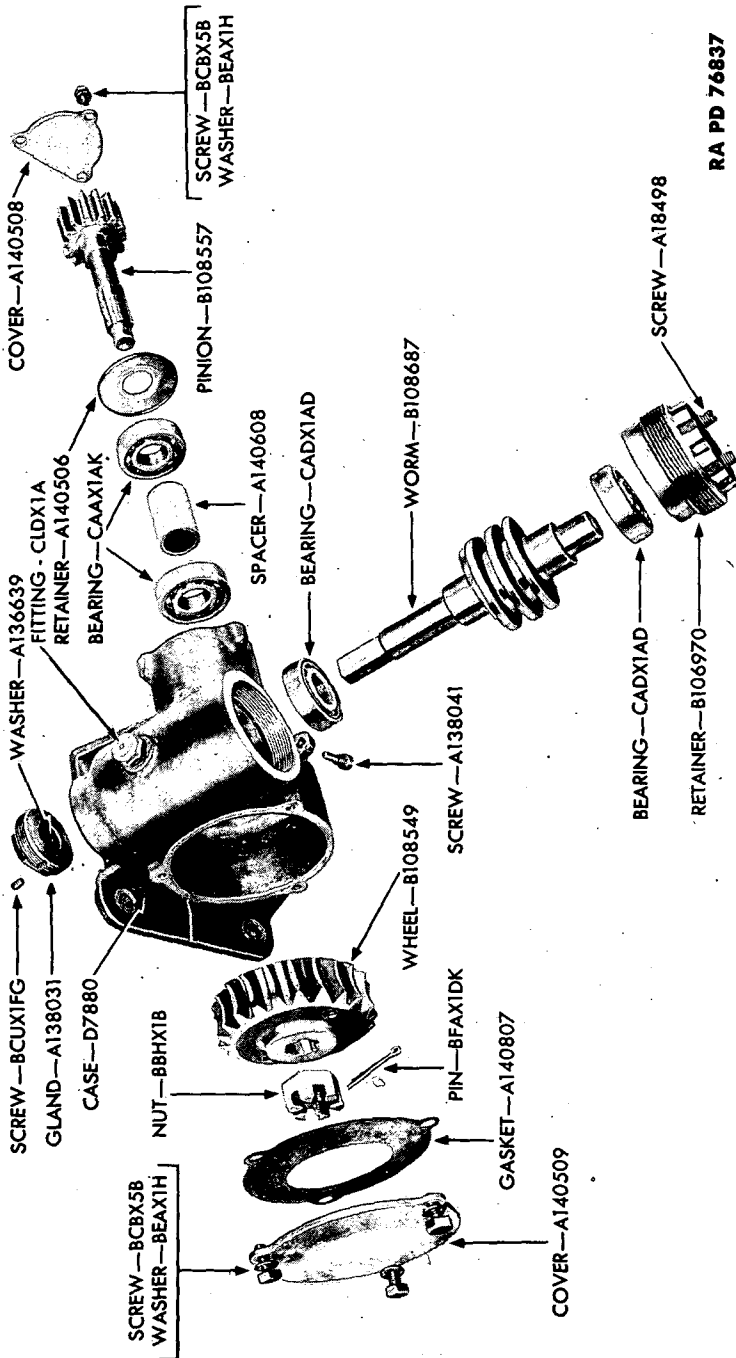

Figure 112—Removing Traversing Gear Case Cover

MAINTENANCE OF FIELD HOWITZER CARRIAGE M3A3



RA PD 76837

Figure 113—Traversing Gear Case—Exploded View

**ORDNANCE MAINTENANCE
75-MM HOWITZERS AND CARRIAGES**

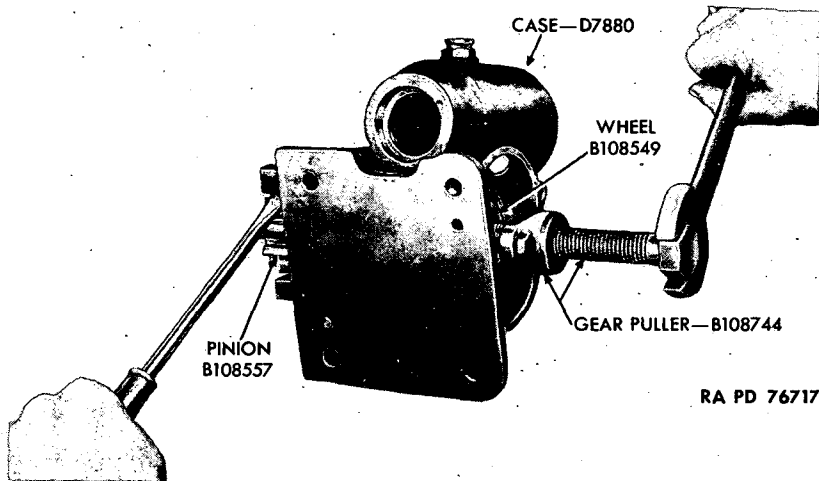

RA PD 76717

Figure 114—Removing Traversing Wheel

(b) Remove the traversing gear case cover (large) and gasket from top of traversing gear case by removing the three screws and washers. This cover must be removed first in order to remove the top right screw and washer from traversing gear case and top carriage (fig. 112).

(c) Remove the four screws and washers that fasten the gear case to the top carriage. Tap gear case lightly to loosen, then lift gear case away. Two dowel pins will come away with gear case.

NOTE: Removal of traversing rack from bottom carriage is covered in paragraph 40 b.

(d) Remove the four screws and washers that fasten the traversing handwheel shaft bracket to the left side of top carriage. Remove traversing handwheel shaft bracket assembly with two dowel pins from top carriage (fig. 110).

(2) **DISASSEMBLY OF TRAVERSING GEAR CASE** (fig. 113).

(a) Remove cotter pin and tap flexible joint off the traversing worm shaft.

(b) Remove screw BCUX1FG from gland A138031. Unscrew and remove gland.

(c) Remove screw A138041, and unscrew and remove retainer B106970. Bearing CADX1AD will come away in the retainer. To remove bearing, remove the two screws from the retainer. Then, using a pin drive punch inserted alternately in these screw holes, tap the bearing out.

MAINTENANCE OF FIELD HOWITZER CARRIAGE M3A3

(d) Unscrew the traversing worm shaft from traversing worm wheel and remove worm from housing. Remove other bearing CADX1AD from worm housing part of gear case.

(e) Remove the three screws and washers from small gear case cover A140508. Remove cover. *NOTE: Large cover was removed when gear case was removed from top carriage.*

(f) Remove cotter pin and nut from end of traversing pinion shaft. Screw the gear puller B108744 in place in the traversing worm wheel. Pull traversing worm wheel from the pinion shaft (fig. 114).

(g) Using a copper hammer, tap the pinion shaft out of the gear case. Remove retainer, bearing, spacer, and another bearing (fig. 113).

(3) **DISASSEMBLY OF TRAVERSING HANDWHEEL SHAFT BRACKET** (fig. 120). There are two of these handwheel shaft bracket assemblies used on this carriage. One is on the traversing handwheel shaft and the other on the elevating handwheel shaft. The parts used in each are identical, with the exception of the brackets. One is a right-hand bracket and the other a left-hand bracket. Disassembly and assembly procedure is the same. This is covered in paragraph 39 b and d.

c. Repairs.

(1) Clean all parts of the traversing mechanism thoroughly.

(2) Examine all parts carefully for cracks, wear, or breakage.

(3) Replace all worn or damaged parts.

d. Assembly and Installation.

(1) Assembly of traversing handwheel shaft bracket. This is covered in paragraph 39 d.

(2) **ASSEMBLY OF TRAVERSING GEAR CASE** (fig. 113).

(a) Place retainer A140506, bearing CAAX1AK, and spacer A140608 on pinion shaft. Place other bearing CAAX1AK into position in traversing gear case. Lay traversing worm wheel in place on bearing. Insert the assembled pinion shaft into gear case.

(b) Push the pinion shaft through traversing worm wheel and turn pinion until the splines in shaft and worm wheel match. Pull the worm wheel into place on the shaft by screwing on nut BBHX1B. Secure nut with cotter pin. Do not put large cover and gasket on gear case until gear case assembly is mounted on top carriage.

(c) Place small cover A140508 in place on gear case and secure with three screws and washers.

(d) When pinion shaft has been installed in gear case, place rear bearing CADX1AD on worm shaft and install unit in place in gear case. Rotate worm shaft while inserting.

(e) Tap the other bearing CADX1AD into place in retainer B106970 and screw assembly into the gear case.

**ORDNANCE MAINTENANCE
75-MM HOWITZERS AND CARRIAGES**

(f) Install gland A138031 over worm shaft and secure in gear case with screw BCUX1FG.

(g) Tighten retainer B106970 to eliminate end play of worm. Secure proper adjustment and lock in place with screw A138041. Install the two screws A18498 in retainer. If backlash between worm and worm wheel exceeds one-quarter turn, replace worm and worm wheel.

(h) Place flexible joint on worm shaft and secure with cotter pin.

(3) **INSTALLATION OF TRAVERSING MECHANISM.**

(a) Secure the traversing gear case assembly to the front of top carriage with four screws, lock washers, and two dowel pins (fig. 112).

(b) Secure the traversing handwheel shaft bracket assembly to the left side of top carriage with four screws and lock washers and with two dowel pins.

(c) Slide the traversing handwheel and handwheel shaft into place through the handwheel shaft bracket.

(d) Insert the end of the traversing handwheel shaft into rear section of flexible joint and secure with cotter pin (fig. 111).

38. TOP CARRIAGE AND PINTLE PIN.**a. General.**

(1) The top carriage of the M3A3 Carriage is a large cast and welded steel unit (fig. 115). It forms the connection between the cradle which supports the bottom sleigh, howitzer and top sleigh, and the bottom carriage. It also provides the ultimate means of traversing the piece.

(2) The traversing mechanism is assembled to the left side and to the front of the top carriage. The traversing mechanism rotates the top carriage by means of a pinion which meshes with a traversing rack. The traversing rack is secured to the front of the bottom carriage. A large steel pintle pin passes vertically through the top and bottom carriages. In operation, the traversing mechanism rotates the top carriage around the pintle pin which is keyed in the bottom carriage (fig. 116).

(3) The elevating mechanism, with the exception of the elevating arc, is also attached to the top carriage.

(4) At the rear top of the top carriage are two arms fitted with bushings. The cradle is attached to the top carriage at these points by means of the cradle trunnion pins. Brackets for supporting the shield and the equilibrators are located at the front of the top carriage.

b. Removal and Disassembly.**(1) REMOVAL OF TOP CARRIAGE.**

(a) Remove shield assembly (par. 34 b).

MAINTENANCE OF FIELD HOWITZER CARRIAGE M3A3

RA PD 26111

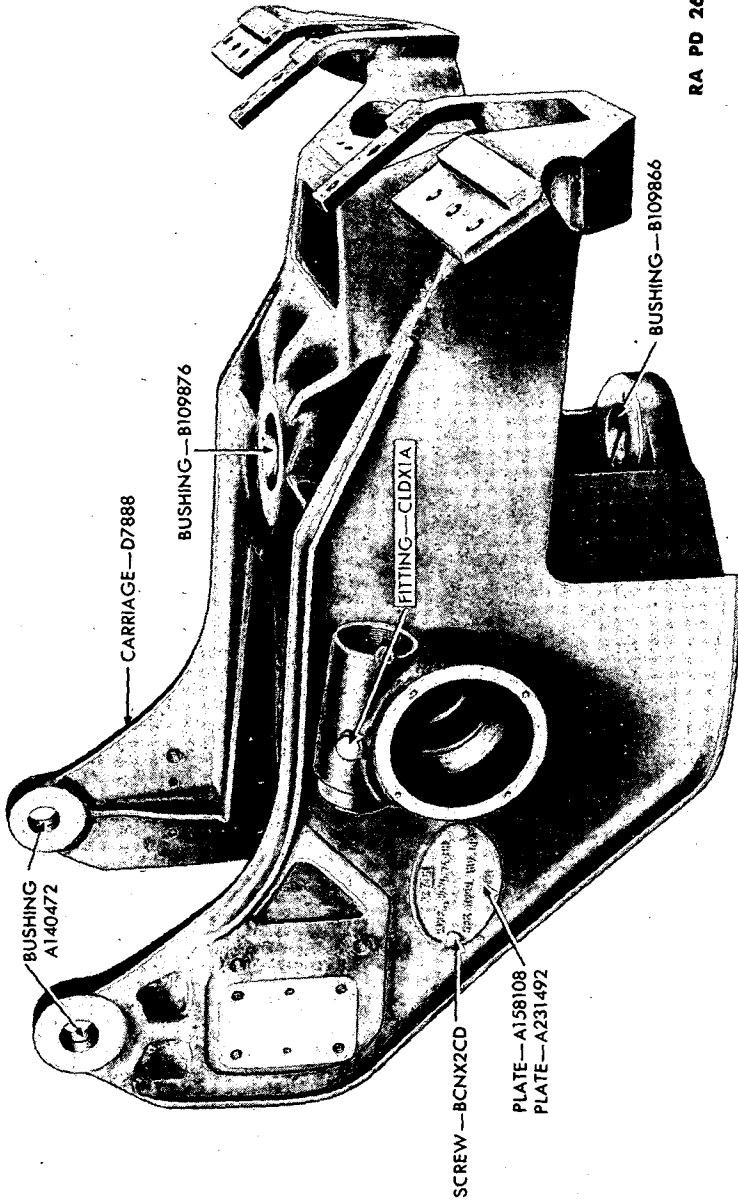
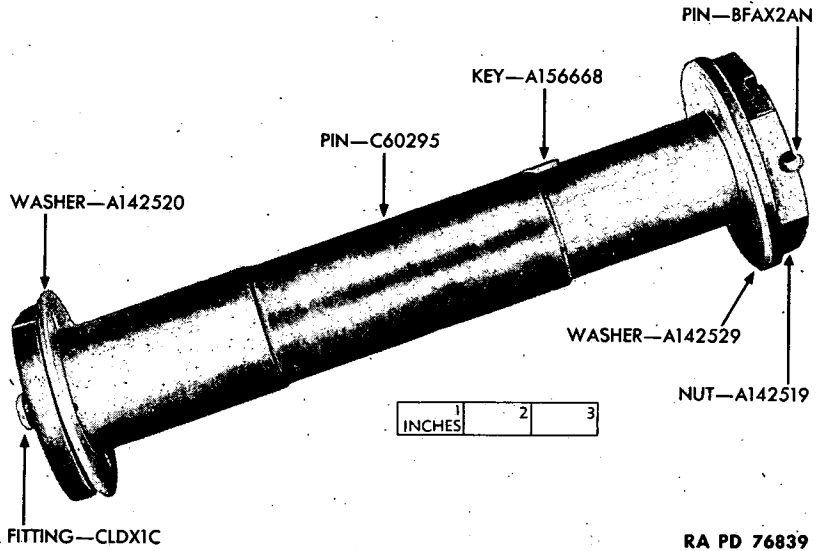

Figure 115—Top Carriage

ORDNANCE MAINTENANCE
75-MM HOWITZERS AND CARRIAGES



RA PD 76839

Figure 116—Pintle Pin

(b) Remove top sleigh, howitzer tube, breech mechanism, and bottom sleigh (TM 9-320).

(c) Remove equilibrators (par. 35 b).

(d) Remove cradle (par. 36 b).

(e) Spread the trails, let firing base hang free, and wheels in traveling position with brakes on.

(f) Remove cotter pin from pintle pin nut. Then using pintle and trail wrench B108514 (fig. 117), remove pintle pin nut. Lower bronze thrust washer will come off (fig. 116). Using copper hammer, tap pintle pin up and out of top and bottom carriages. Lift top bronze thrust washer away. *CAUTION: The copper hammer used to tap the pintle pin must not strike the brass bushing of the top carriage. A blow to the bushing may cause it to bind on the pintle pin, resulting in difficult traverse after assembly.*

(g) Swing top carriage from side to side and at the same time pull top carriage to rear and away from bottom carriage. Two men will be required to do this with safety.

(2) DISASSEMBLY OF TOP CARRIAGE.

(a) When the traversing mechanism and the elevating mechanism are removed from the top carriage, the top carriage is completely disassembled.

MAINTENANCE OF FIELD HOWITZER CARRIAGE M3A3

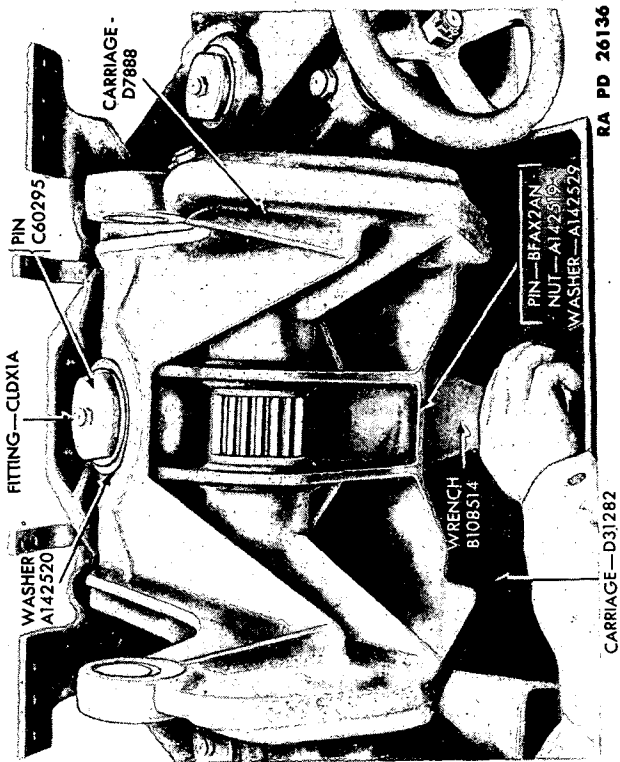

Figure 117—Removing Pintle Pin

**ORDNANCE MAINTENANCE
75-MM HOWITZERS AND CARRIAGES**

(b) Procedure for disassembly, repair, and assembly of traversing mechanism is described in paragraph 37.

(c) Procedure for disassembly, repair, and assembly elevating mechanism is described in paragraph 39.

NOTE: It is not necessary to remove the top carriage from the carriage to disassemble or assemble traversing or elevating mechanisms. Disassembly and assembly of elevating mechanisms are much easier, however, when top carriage is removed.

c. Repairs.

(1) Clean the top carriage, pintle pin, and bronze thrust washers thoroughly.

(2) Examine all parts carefully for cracks, wear, or breakage.

(3) Replace all worn or damaged parts.

(4) When cradle trunnion pin bushing is replaced, ream new bushing to $1.125 + 0.005$ -inch diameter.

d. Assembly and Installation.

(1) **ASSEMBLY.** When traversing and elevating mechanisms are installed on top carriage, the top carriage is completely assembled (pars. 37 and 39).

(2) **INSTALLATION OF TOP CARRIAGE.**

(a) Lift the top carriage in place and line up pintle pin hole in top carriage with hole in bottom carriage (two men).

(b) Place the upper bronze thrust washer on the top carriage with oil grooves next to head of pintle pin.

(c) Line up pintle pin key with keyway in bottom carriage. Insert pintle pin and tap down into position.

(d) Place lower bronze thrust washer on bottom of pintle pin with oil grooves up. Screw the nut on the pintle pin with pintle and trail wrench B108514 (fig. 117). Secure nut with cotter pin.

(e) Replace cradle (par. 36 d).

(f) Replace equilibrators (par. 35 d).

(g) Replace bottom sleigh, breech mechanism, howitzer tube, and top sleigh (TM 9-320).

(h) Replace shield (par. 34 d).

39. ELEVATING MECHANISM.

a. General.

(1) The entire elevating mechanism, with the exception of the elevating arc, is assembled to the top carriage (fig. 118).

MAINTENANCE OF FIELD HOWITZER CARRIAGE M3A3

RA PD 77094

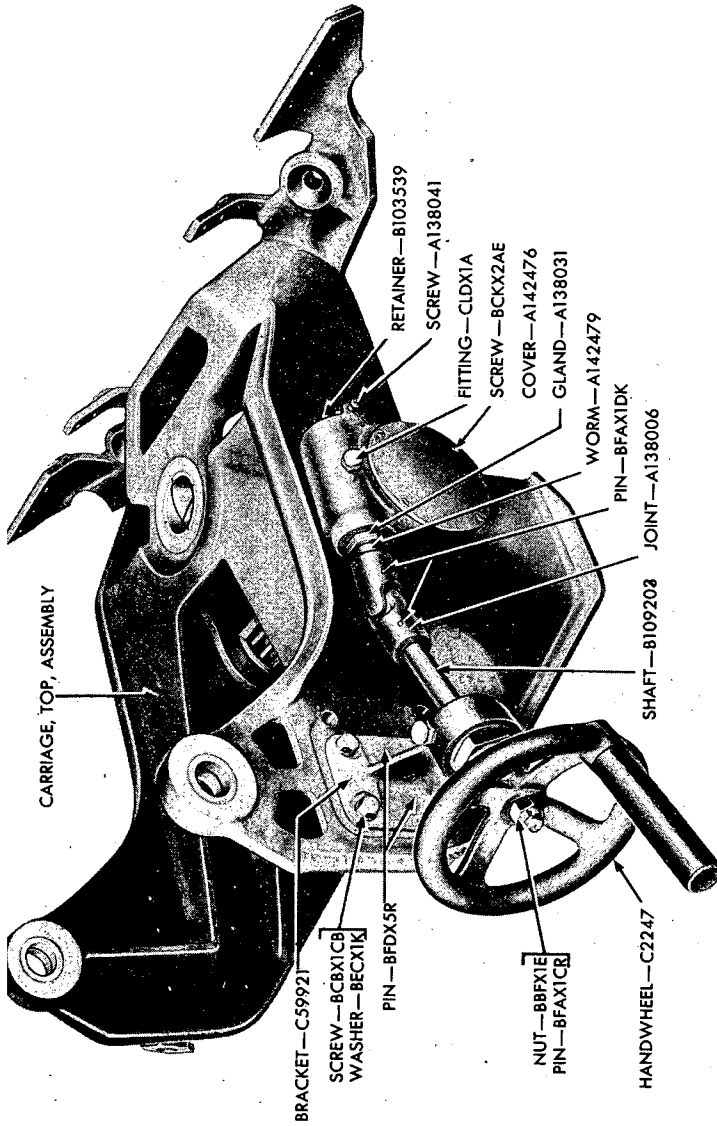

Figure 118—Top Carriage and Elevating Mechanism

ORDNANCE MAINTENANCE
75-MM HOWITZERS AND CARRIAGES

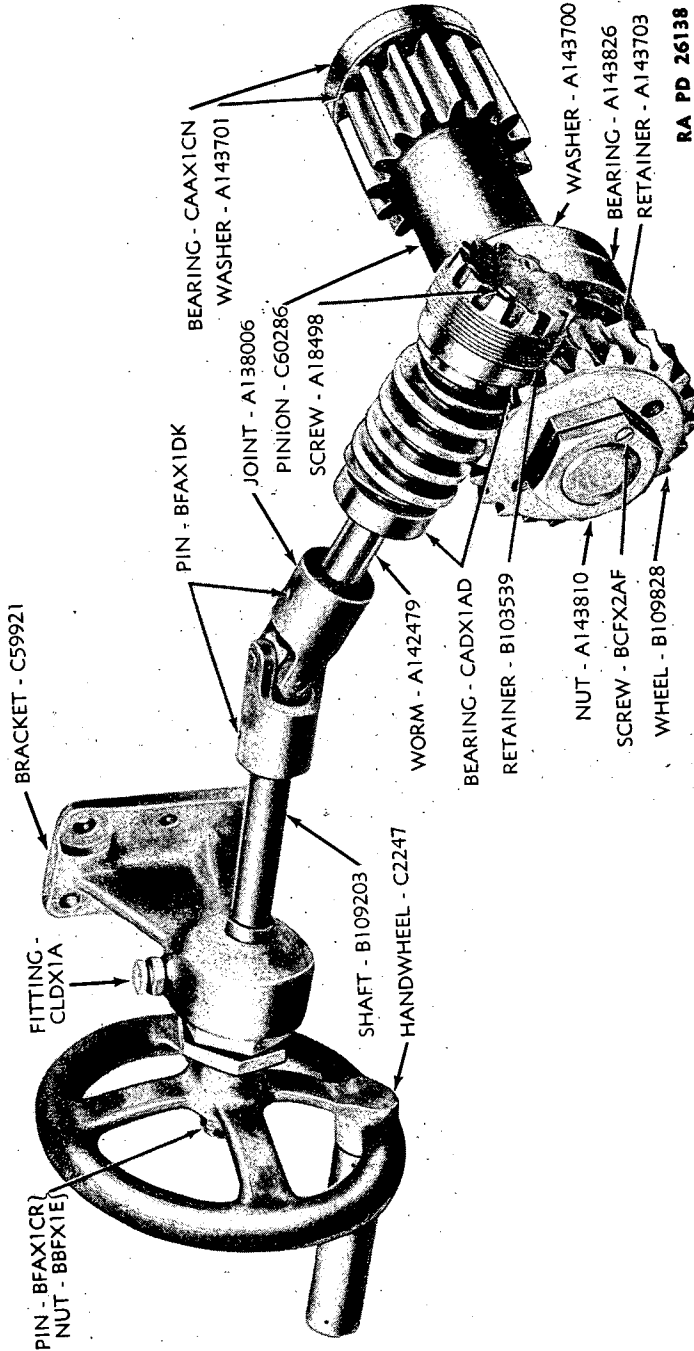

Figure 119—75-mm Howitzer Carriage M3A3—Elevating Mechanism Arrangement.

MAINTENANCE OF FIELD HOWITZER CARRIAGE M3A3

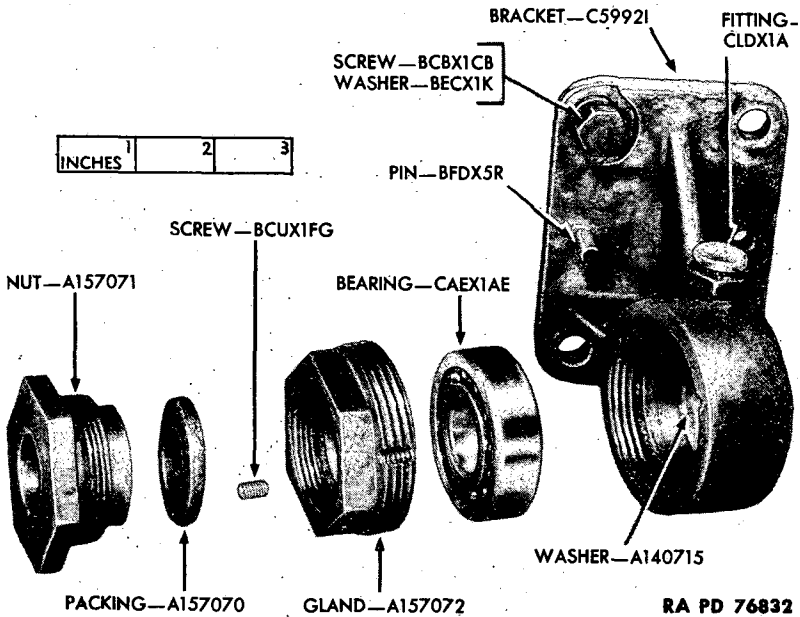

Figure 120—Handwheel Shaft Bracket—Exploded View

(2) The tipping parts of the piece may be elevated or depressed by means of the elevating handwheel, located on the right side of the top carriage.

(3) The major parts of the elevating mechanism are the elevating handwheel, handwheel shaft, handwheel shaft bracket, flexible joint, worm, worm wheel, pinion, and antifriction bearings (fig. 119).

b. Removal and Disassembly.

(1) Removal of elevating mechanism from top carriage constitutes disassembly of the elevating mechanism. *NOTE: Disassembly of elevating mechanism is herein described and illustrated with the top carriage removed from the carriage (par. 38 b).*

(2) REMOVE ELEVATING HANDWHEEL AND HANDWHEEL SHAFT.

(a) Remove cotter pin from rear half of flexible joint (fig. 120). Then loosen handwheel shaft packing nut (fig. 120).

(b) Pull handwheel and shaft back out of elevating handwheel shaft bracket.

(3) REMOVE ELEVATING HANDWHEEL SHAFT BRACKET (figs. 119 and 120).

(a) Remove four screws and washers from handwheel shaft bracket and top carriage.

ORDNANCE MAINTENANCE 75-MM HOWITZERS AND CARRIAGES

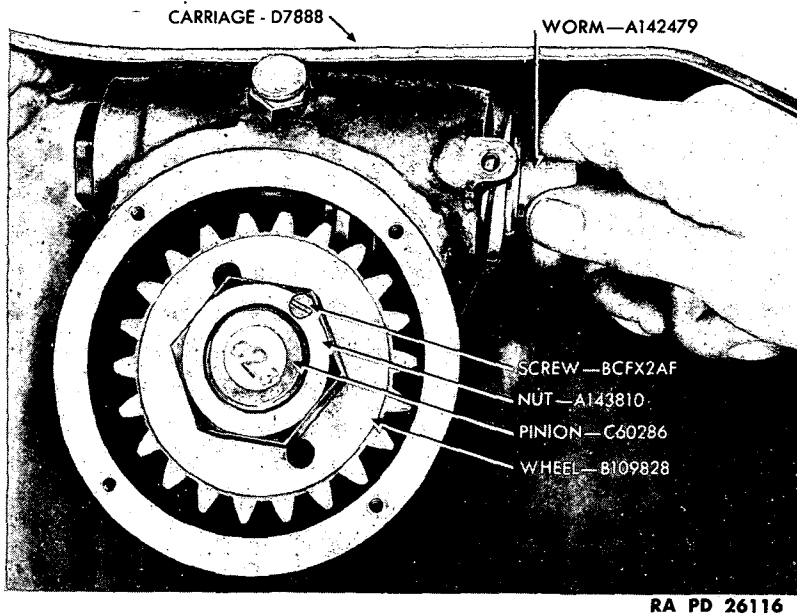

RA PD 26116

Figure 121—Removing Elevating Worm

- (b) Tap bracket loose and remove bracket and two dowel pins.
- (4) DISASSEMBLE ELEVATING HANDWHEEL SHAFT BRACKET (fig. 120).
- (a) Remove packing nut and packing. Unscrew headless set screw from gland A157072.
- (b) Unscrew and remove gland. Remove bearing. To remove washer A140715, pry it out with a pointed tool.
- (5) REMOVE ELEVATING WORM.
- (a) Remove retainer lock screw A138041, and unscrew and remove retainer B103539 and bearing (fig. 118).
- (b) Remove cotter pin from front section of flexible joint and remove joint from worm shaft.
- (c) Remove headless set screw from gland A138031. Unscrew and remove gland and packing.
- (d) Rotate elevating worm in a clockwise direction and remove it from the housing (fig. 121). Then remove the other worm bearing from the housing.
- (6) REMOVE BEARING FROM BEARING RETAINER.
- (a) Remove two screws from front of bearing retainer.

MAINTENANCE OF FIELD HOWITZER CARRIAGE M3A3

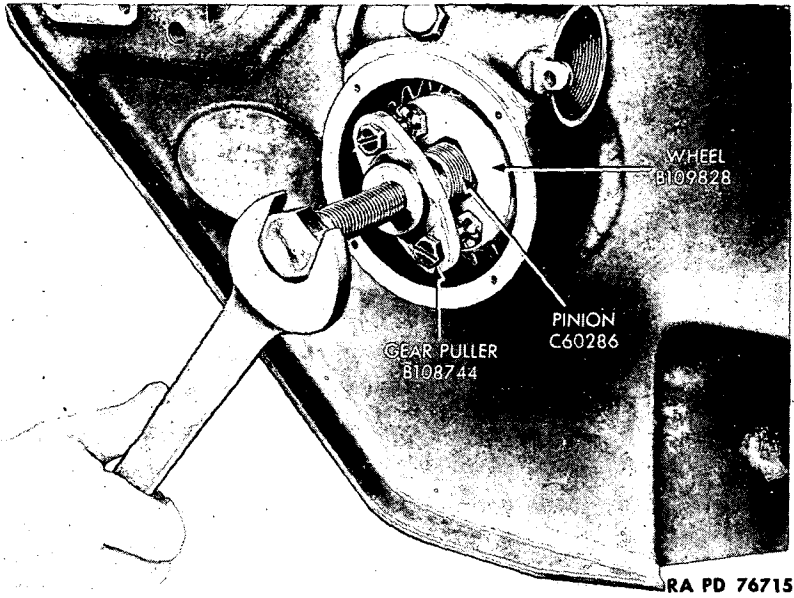

Figure 122—Removing Elevating Worm Wheel

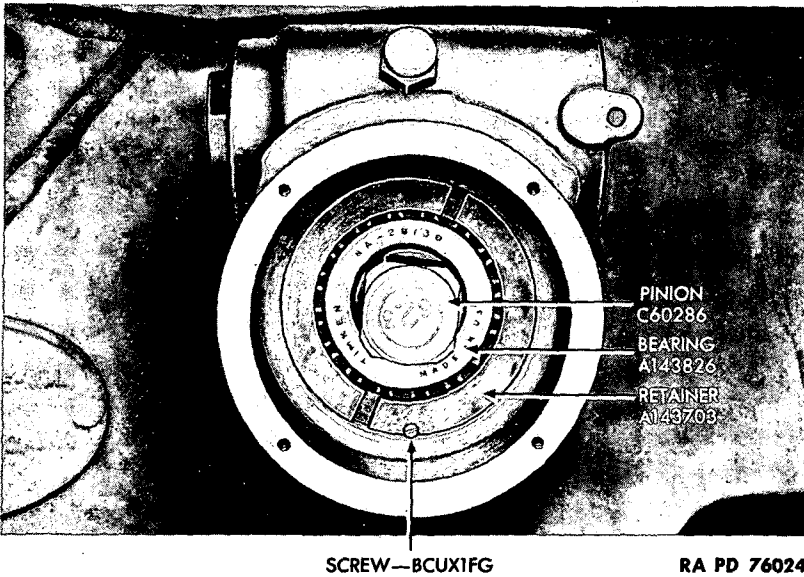

Figure 123—Bearing Retainer in Position

ORDNANCE MAINTENANCE
75-MM HOWITZERS AND CARRIAGES

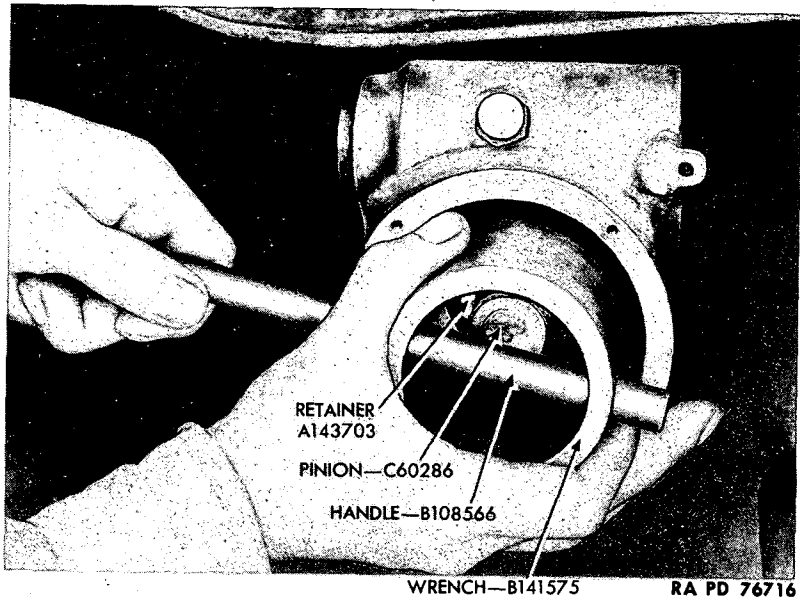

Figure 124—Removing Bearing Retainer

(b) Insert a small drift in each screw hole and alternately tap bearing from retainer.

(7) REMOVE ELEVATING WORM WHEEL AND BEARING RETAINER.

(a) Remove four screws BCKX2AE from gear case cover A142476 (fig. 118) and remove cover and gasket.

(b) Take out screw BCFX2AF, and elevating pinion nut A143810 (fig. 121) is free to be removed.

(c) Screw gear puller B108744 into place in holes in worm wheel and remove worm wheel from pinion shaft (fig. 122).

(d) Remove screw BCUX1FG from bearing retainer A143703 (fig. 123). Then using socket wrench B141575 and handle B108566, unscrew and remove the bearing retainer (figs. 31 and 124).

(8) REMOVE ELEVATING MECHANISM PINION SHAFT.

(a) Go to the left or opposite side of top carriage. Remove screw from gland A143812. Unscrew and remove the gland (fig. 125).

(b) Drive the pinion shaft from the left side of top carriage out through the right side.

MAINTENANCE OF FIELD HOWITZER CARRIAGE M3A3

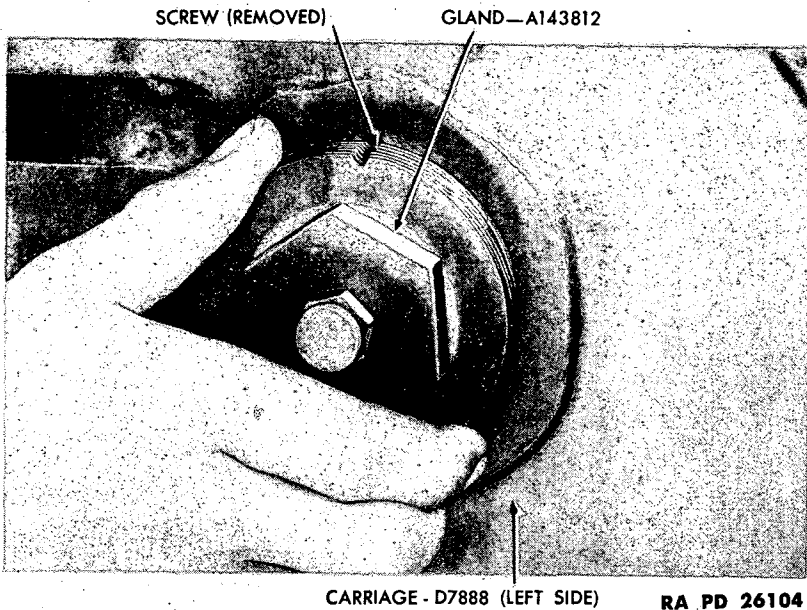

Figure 125—Removing Elevating Gear Case Gland

(9) DISASSEMBLE ELEVATING PINION SHAFT.

(a) When the pinion shaft is driven out, as above, it will have two bearings, a washer, and nut on it.

(b) Remove the screw from the nut and remove nut.

(c) Press the bearings and washer off on an arbor press.

c. Repairs.

(1) Clean all parts of the elevating mechanism thoroughly.

(2) Examine all parts carefully for cracks, wear, or breakage.

(3) Replace all worn or damaged parts.

(4) Remove all burrs, nicks, and scores from gears and shafts with a smooth file. Polish with crocus cloth. Then clean again.

d. Assembly and Installation.

(1) **ASSEMBLE ELEVATING PINION SHAFT.**

(a) Press bearings and washer in place on pinion shaft on arbor press.

(b) Screw the nut on the left end of pinion and secure with screw.

(c) Insert the pinion shaft with bearings assembled in place in the top carriage. The pinion shaft must be inserted from the right side. Tap into place so bearings will be seated.

**ORDNANCE MAINTENANCE
75-MM HOWITZERS AND CARRIAGES**

(d) Screw the gland in place in the left side of top carriage and secure with screw (fig. 125).

(2) ASSEMBLE ELEVATING WORM WHEEL.

(a) Screw the bearing retainer in place, using socket wrench B141575 and handle B108566 (fig. 124). Secure retainer with set screw (fig. 123).

(b) Tap the worm wheel in place on pinion shaft and draw all the way into position by screwing on the nut A143810 (fig. 121). Secure nut with set screw. Place gasket and gear case cover in place and secure with four screws.

(3) ASSEMBLE ELEVATING WORM.

(a) Place the ball bearing in position in the rear of the worm housing.

(b) Insert the worm by turning it in a counterclockwise direction to mesh with worm wheel. Make certain the worm seats up against bearing just installed.

(c) Assemble the other ball bearing in place in the retainer B103539 (fig. 118).

(d) Slide gland A138031 and packing into place on rear of worm shaft. Screw gland into place in housing and secure with headless set screw.

(e) Screw the retainer and bearing into place in the front of housing. Adjust for proper end play of worm and worm wheel. Then lock with the lock screw A138041 (fig. 118). Screw the two screws into place in front of retainer.

(f) Tap the flexible joint onto rear end of worm shaft and secure with cotter pin.

(4) ASSEMBLE ELEVATING HANDWHEEL SHAFT BRACKET (fig. 120).

(a) Make certain the washer A140715 is in the bracket and that it is in good condition.

(b) Tap the bearing into place in the bracket. Screw the gland in after the bearing. Secure the gland with headless set screw.

(c) Place new packing in the gland, then screw the nut into the gland.

NOTE: Do not tighten this nut until elevating handwheel shaft has been installed.

(5) INSTALL ELEVATING HANDWHEEL AND SHAFT (figs. 118 and 119).

(a) Slide the elevating handwheel shaft in through the elevating handwheel shaft bracket.

MAINTENANCE OF FIELD HOWITZER CARRIAGE M3A3

(b) Insert the front end of the shaft in the rear section of the flexible joint. Secure with cotter pin.

(c) Tighten nut in elevating handwheel shaft bracket.

40. BOTTOM CARRIAGE, WHEEL CARRIERS, AND FIRING BASE.**a. General.**

(1) The bottom carriage of the 75-mm Field Howitzer Carriage M3A3 is a large cast, welded, and machined unit (fig. 141). It forms the connection between the top carriage and trails. It also serves as an axle, as it provides the means of supporting the wheel carriers.

(2) The firing base (fig. 142) is also hinged to the firing base hinge brackets which are integral with the bottom carriage. When the materiel is in the firing position, the firing base is swung down underneath the bottom carriage and latched in that position by the firing base lock assembly (fig. 7). The firing base acts as a cradle support when the materiel is in the traveling position (fig. 9).

(3) In addition to the above, the bottom carriage is fitted with a pintle bearing, trail brackets, trail lock pin brackets, wheel latch brackets, and traversing rack pad (fig. 141). The traversing rack is attached to the front of the bottom carriage at the center.

b. Removal and Disassembly.

(1) Disassemble carriage through removal of top carriage as outlined in paragraph 38 b.

(2) REMOVAL OF WHEELS, WHEEL HUB, AND DRUM.

(a) Place the trails in a parallel position, swing the firing base down into firing position, and secure with the firing base lock.

(b) Place the wheel carrier locks in the unlocked position. Insert handspikes in each handspike socket of the wheel carrier, and with two men working in unison, raise the wheels simultaneously (fig. 126) until carriage rests squarely on the firing base (fig. 127).

(c) Continue on around with the handspikes until the wheels are up in the firing position (fig. 128). Lock them in that position by means of the wheel carrier locks.

(d) Put the hand brakes in the "on" position. Loosen and remove the five wheel stud nuts with wrench and handle provided for this purpose (fig. 129) (wrench C59566 and handle B108566) (fig. 31). Remove wheel and tire. Repeat the above to remove the other wheel.

(e) Unscrew hub cap. Remove cotter pin from wheel spindle nut. Unscrew spindle nut (fig. 130) and wheel spindle outer washer. Pull out hub and drum to loosen outer cone and roller. Remove outer

ORDNANCE MAINTENANCE
75-MM HOWITZERS AND CARRIAGES

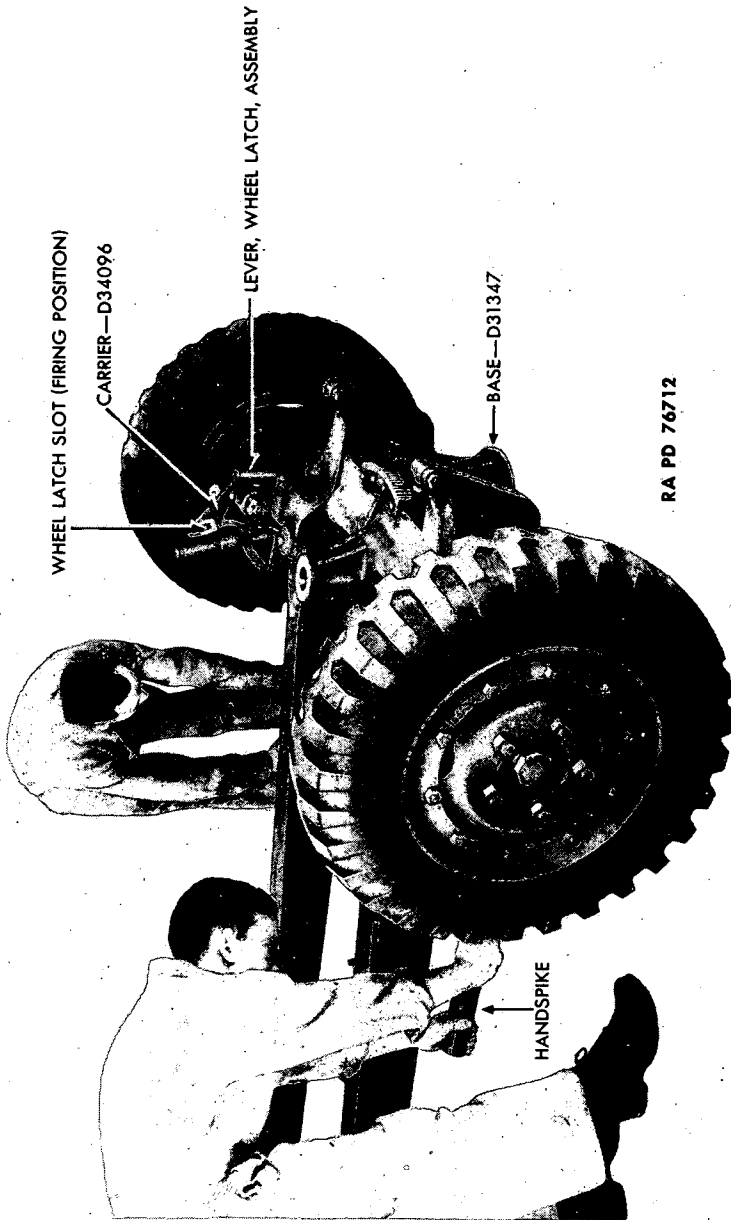

RA PD 76712

Figure 126—Raising Wheels to Firing Position—Start

MAINTENANCE OF FIELD HOWITZER CARRIAGE M3A3

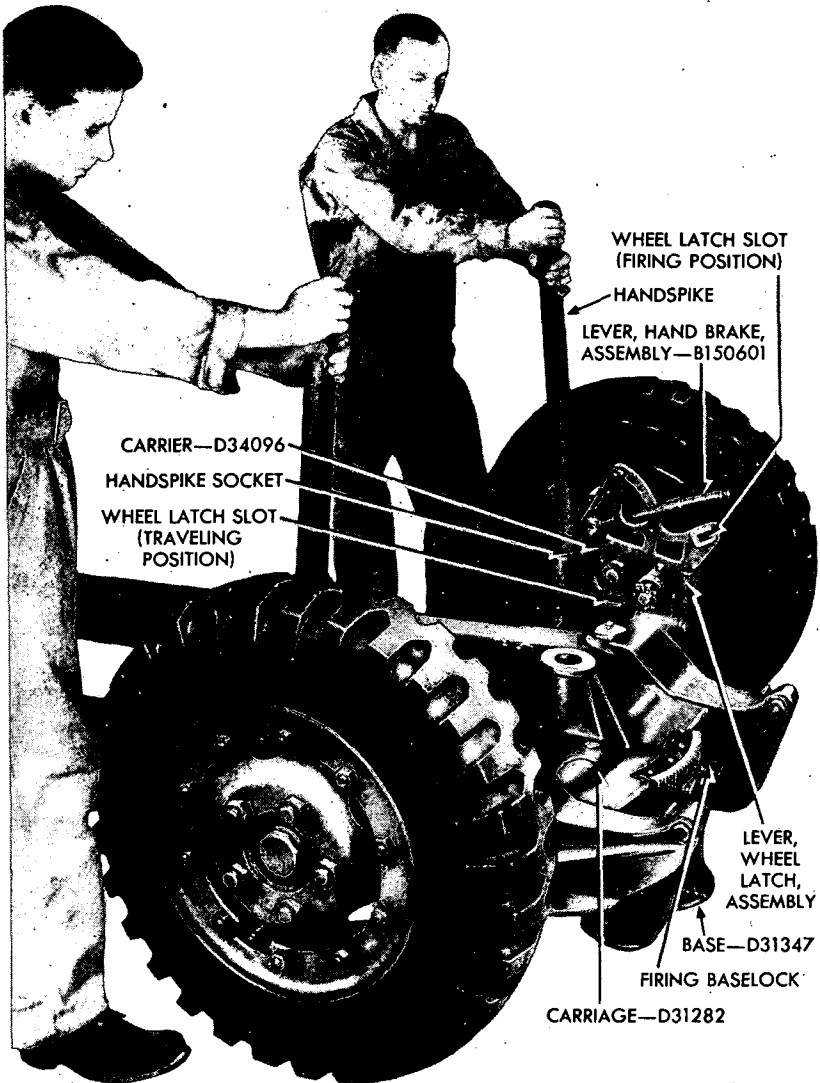

RA PD 77069

Figure 127—Raising Wheels to Firing Position—Halfway

ORDNANCE MAINTENANCE
75-MM HOWITZERS AND CARRIAGES

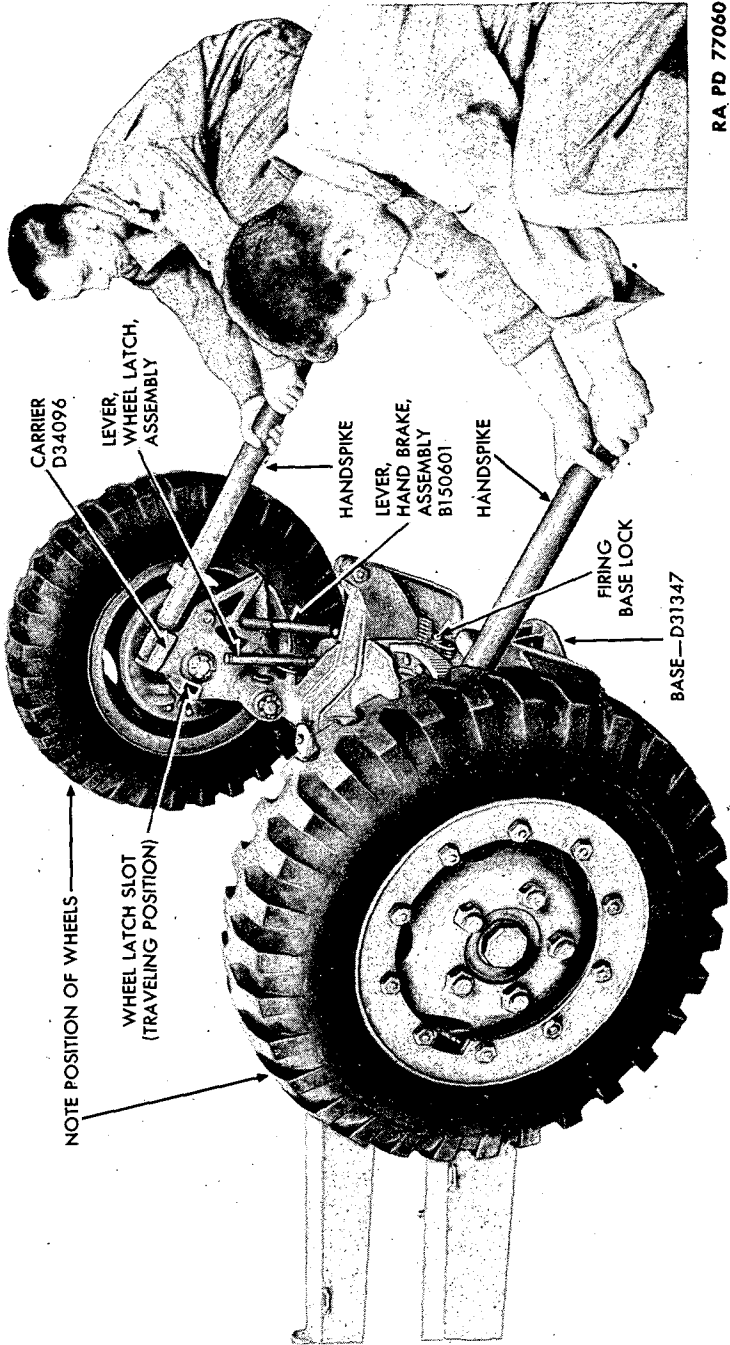

RA PD 77060

Figure 128—Wheels Raised to Firing Position

MAINTENANCE OF FIELD HOWITZER CARRIAGE M3A3

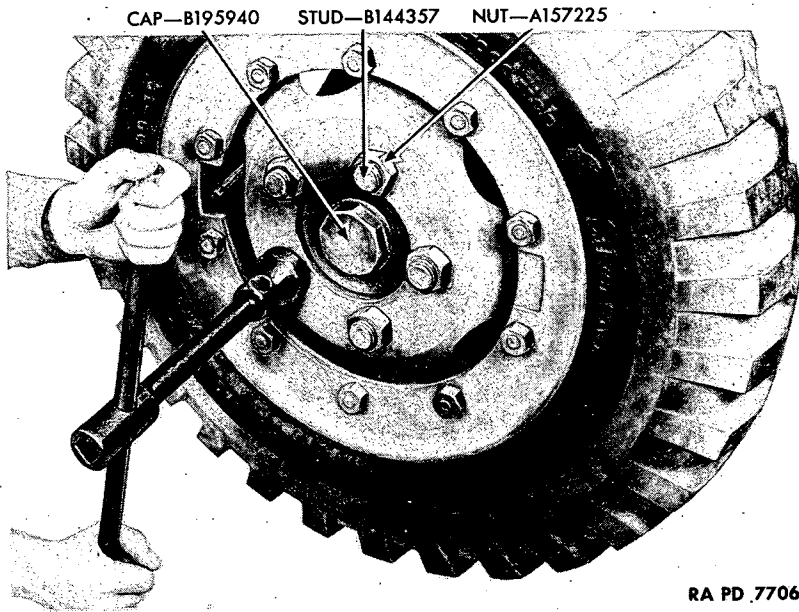

Figure 129—Removing Wheel

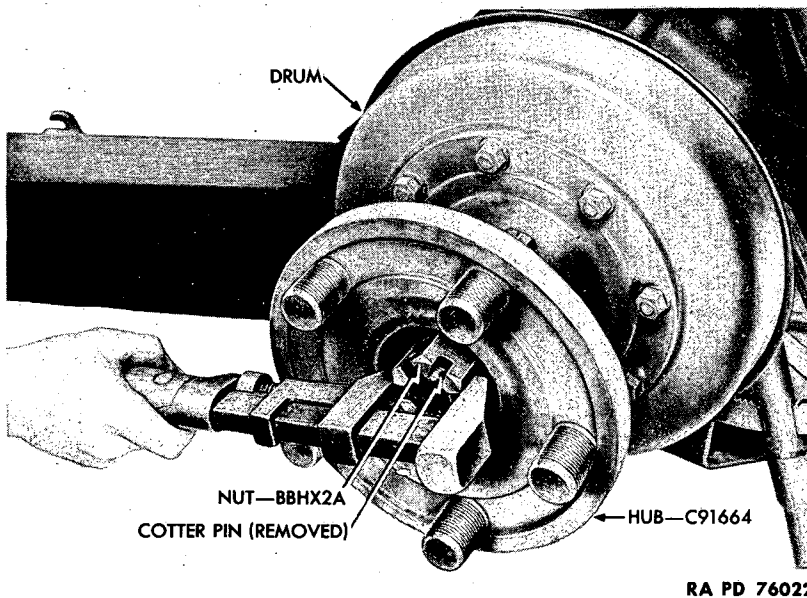

Figure 130—Removing Wheel Spindle Nut

ORDNANCE MAINTENANCE
75-MM HOWITZERS AND CARRIAGES

PLATE, BRAKE HOUSING, ASSEMBLY

SHOE, BRAKE, ASSEMBLY

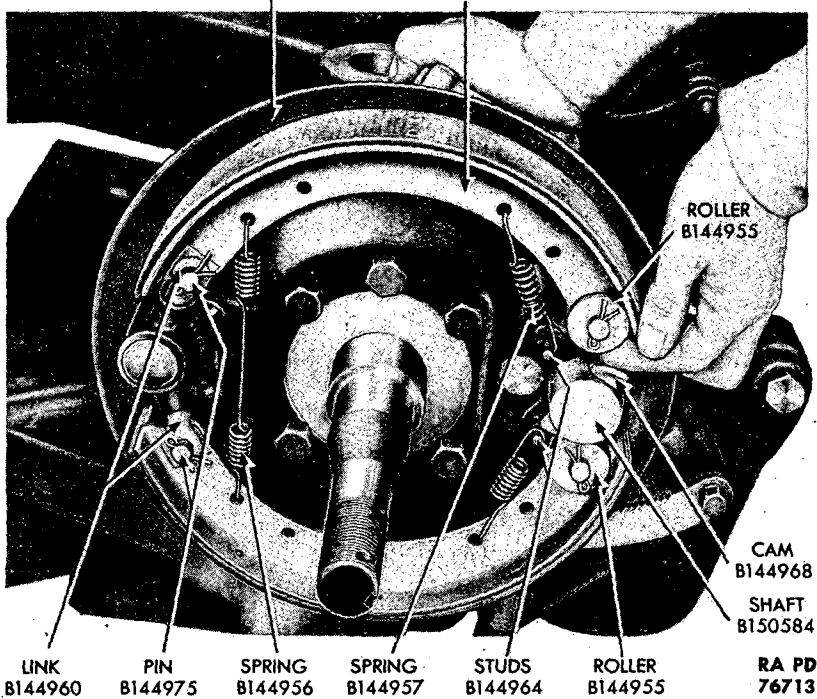

Figure 131—Removing Brake Shoe Assembly

cone and roller and slide the hub and drum off the wheel spindle.
NOTE: The inner roller bearing and retainer will come away in the hub. Repeat above to remove the other wheel hub and drum.

(3) **REMOVAL OF BRAKE MECHANISM FROM WHEEL CARRIER.** The wheel carriers can be removed from the bottom carriage with the brake mechanism intact if so desired. *NOTE:* However, in this outline, the procedure of removing the brake mechanism from the wheel carriers before the wheel carriers are removed from the bottom carriage is followed.

(a) Raise upward and swing outward on one brake shoe assembly and disengage the cam roller from the brake cam (fig. 131). Remove the two short brake shoe retracting springs and the one long spring. Lift off the two brake shoe assemblies and remove the brake cam from the brake cam shaft. Repeat above operations to remove other brake mechanism.

MAINTENANCE OF FIELD HOWITZER CARRIAGE M3A3

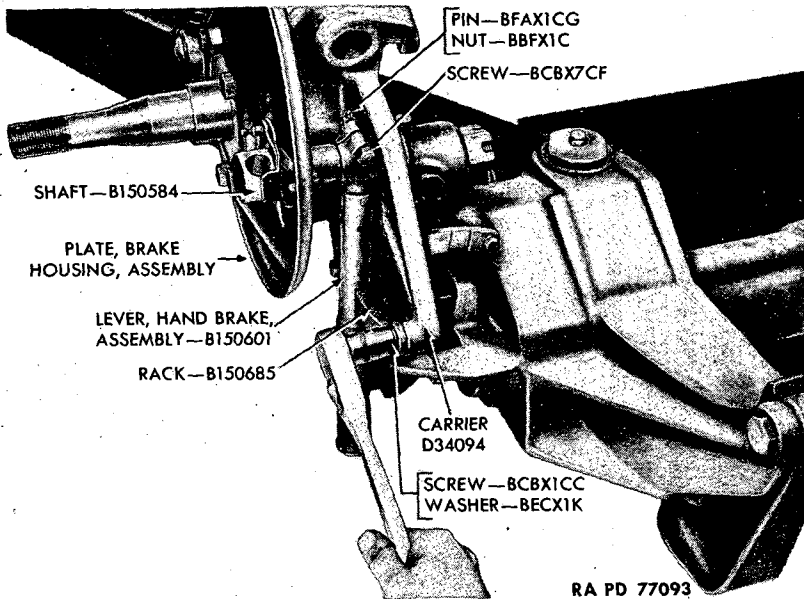

RA PD 77093

Figure 132—Removing Hand Brake Lever**(4) REMOVAL OF HAND BRAKE LEVER (fig. 132).**

(a) Remove the screws and washers that secure the brake rack to the wheel carrier. Then remove cotter pin, nut, and screw from the brake lever clamp. Tap the brake cam shaft out of the lever and brake housing plate.

(b) Remove the six screws, nuts, and washers from brake housing plate. Remove plate from wheel carrier. Repeat above operations to remove other hand brake lever and brake housing plate.

(5) REMOVAL OF WHEEL SPINDLE (fig. 133).

(a) Do not remove the wheel spindle unless it needs replacing.

(b) Remove cotter pin and nut A157539.

(c) Tap wheel spindle out of wheel carrier.

(6) REMOVAL OF WHEEL CARRIER (figs. 133 and 134).

(a) Remove cotter pin from wheel carrier pin nut. Unscrew nut and remove the wheel carrier pin lock washer and bronze thrust washer.

(b) Tap the wheel carrier out of bottom carriage.

(c) Repeat to remove other wheel carrier.

(7) REMOVAL OF TRAILS (figs. 135 and 136).

ORDNANCE MAINTENANCE
75-MM HOWITZERS AND CARRIAGES

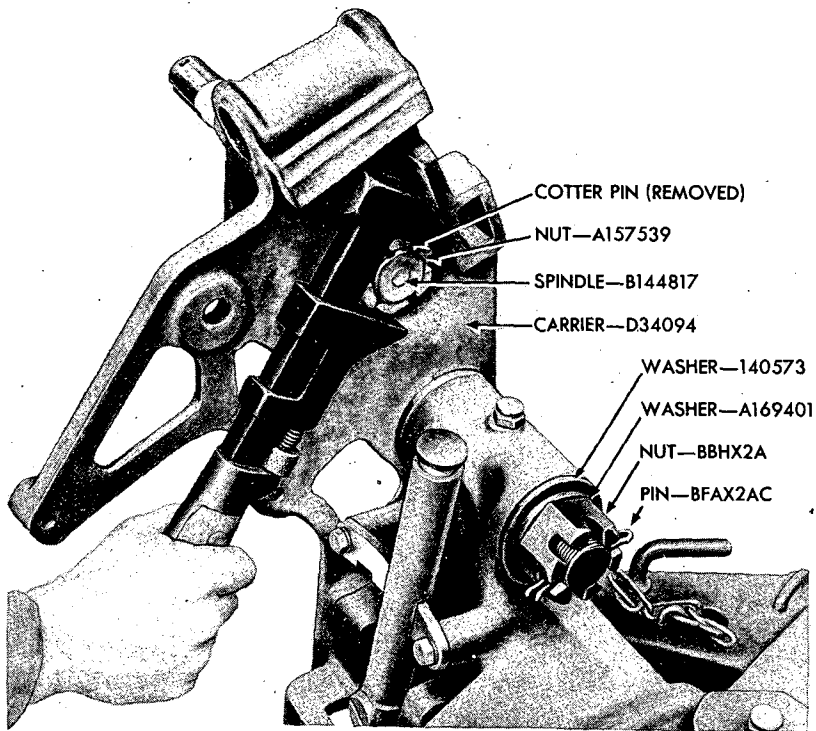

RA PD 76710

Figure 133—Removing Wheel Spindle

(a) Remove cotter pin from trail hinge pin and nut. Using pintle and trail wrench B108514, remove trail hinge pin nut.

(b) Tap trail hinge pin up and out of trail and bottom carriage. Remove lock pin from carriage.

(c) Swing the trail in toward the center far enough to insert the trail lock pin in the bracket in bottom carriage but outside the trail (fig. 136). Now swing the trail outward. The trail bumper will contact the trail lock pin and act as a pry for removing front of trail from bottom carriage. **CAUTION:** Be careful not to damage trail lock pin and chain assembly. Two men will be needed to remove the trails with safety.

(d) Repeat the above operations to remove the other trail.

(8) REMOVAL OF FIRING BASE (fig. 137).

(a) Remove the cotter pin and nut from each of the firing base hinge pins.

MAINTENANCE OF FIELD HOWITZER CARRIAGE M3A3

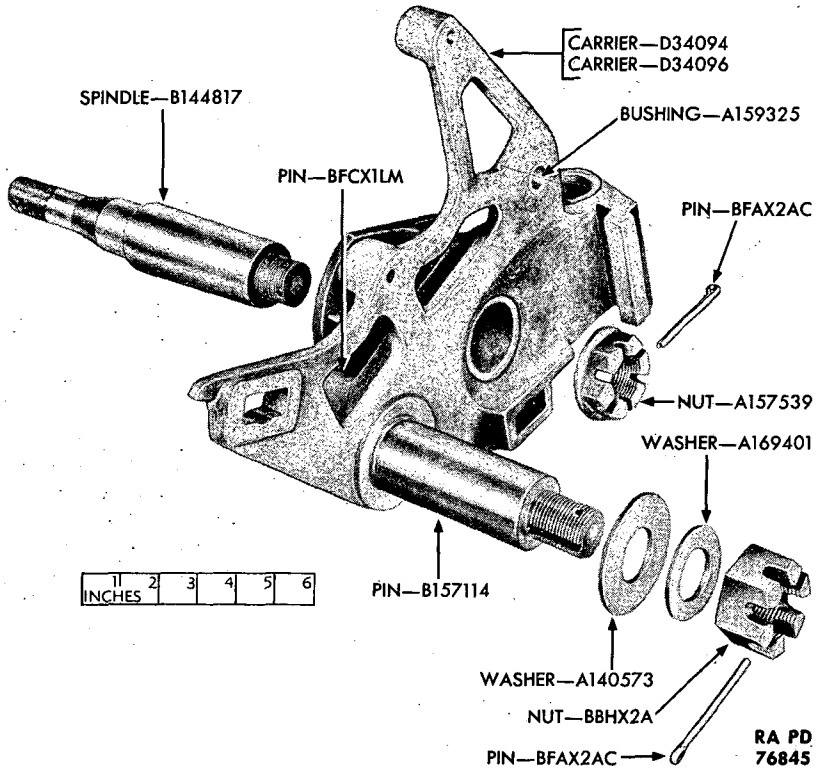

Figure 134—Wheel Carrier Assembly

- (b) Drive the hinge pins out of bottom carriage and firing base.
- (c) Lift bottom carriage from firing base.
- (9) **DISASSEMBLY OF WHEEL CARRIER LATCH** (figs. 138 and 139).
 - (a) Remove the two screws A161601 from the wheel latch lever. Remove the two screws and washers from the wheel carrier latch rack.
 - (b) Slide wheel carrier latch bolt out and remove wheel latch lever assembly.
 - (c) The wheel latch lever is disassembled by removing the rack from the lever handle. The plunger and spring can then be removed from the handle.
 - (d) Repeat the above operations to remove and disassemble the other wheel carrier latch.

ORDNANCE MAINTENANCE
75-MM HOWITZERS AND CARRIAGES

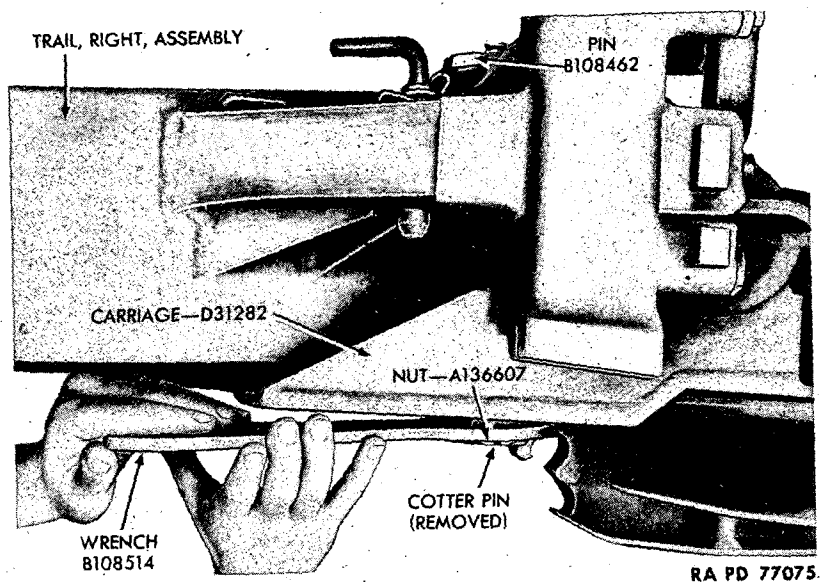

Figure 135—Removing Trail Hinge Pin

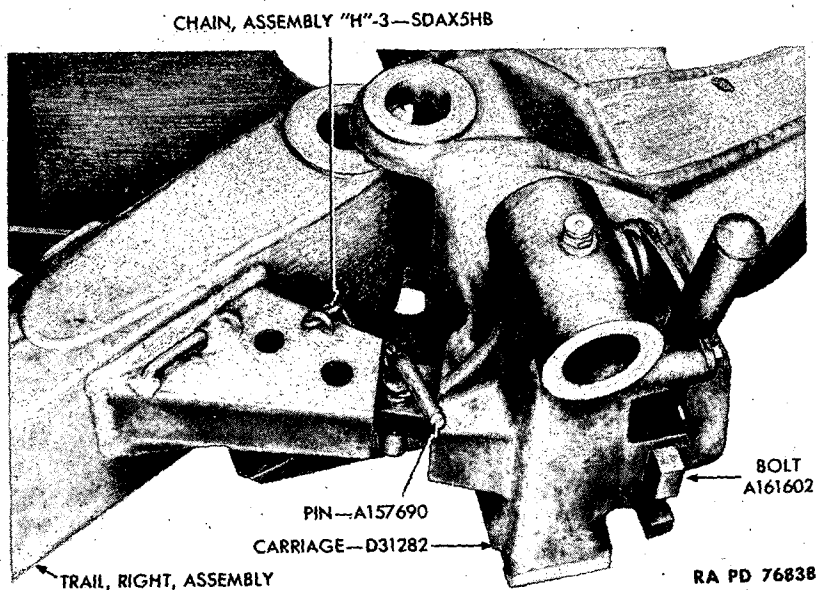

Figure 136—Removing Trail

MAINTENANCE OF FIELD HOWITZER CARRIAGE M3A3

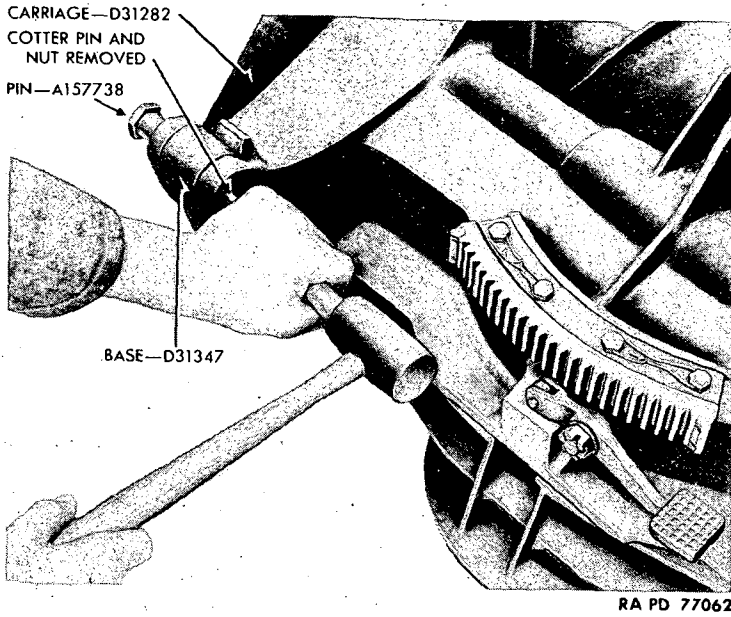

Figure 137—Removing Firing Base

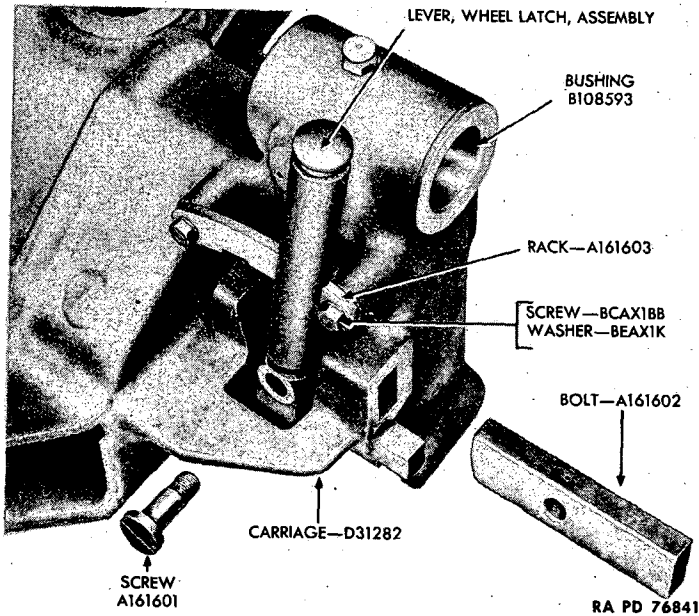

Figure 138—Wheel Latch Lever Group

**ORDNANCE MAINTENANCE
75-MM HOWITZERS AND CARRIAGES**

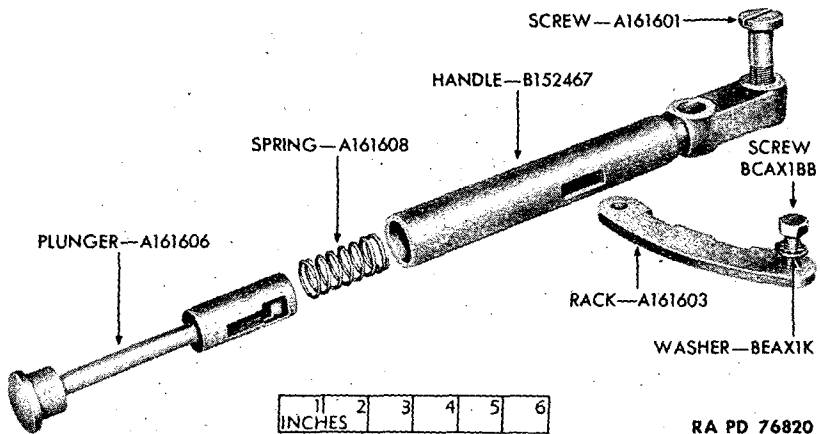

Figure 139—Wheel Latch Lever—Exploded View

(10) DISASSEMBLY OF FIRING BASE LOCK (fig. 140).

(a) Remove the two cotter pins from pin BFEX1AD and remove this pin from the pedal and plunger. Remove plunger and spring.

(b) Remove cotter pin, nut, and washer from stud A157734 and pull pedal from stud.

(c) Unscrew and remove retainer A157735 if worn or damaged.

(11) REMOVAL OF TRAVERSING RACK (fig. 140).

(a) Remove the two safety wires that lock screws in the traversing rack.

(b) Unscrew and remove the four screws.

(c) Using a copper hammer, tap the traversing rack from its pad on the bottom carriage.

c. Repairs.

(1) Clean all parts of the bottom carriage, wheel carriers, wheel carrier latch, firing base, firing base lock, and traversing rack thoroughly (figs. 134, 139, 140, 141, and 142).

(2) Examine all parts carefully for cracks, wear, or breakage.

(3) Replace all worn or damaged parts.

(4) Remove all burrs, nicks, or scores from the various parts with a smooth file. Polish with crocus cloth, and clean thoroughly.

d. Assembly and Installation.

(1) **INSTALL TRAVERSING RACK (figs. 140 and 141).**

(a) Place the traversing rack in position on the mounting pad on the front of the bottom carriage.

MAINTENANCE OF FIELD HOWITZER CARRIAGE M3A3

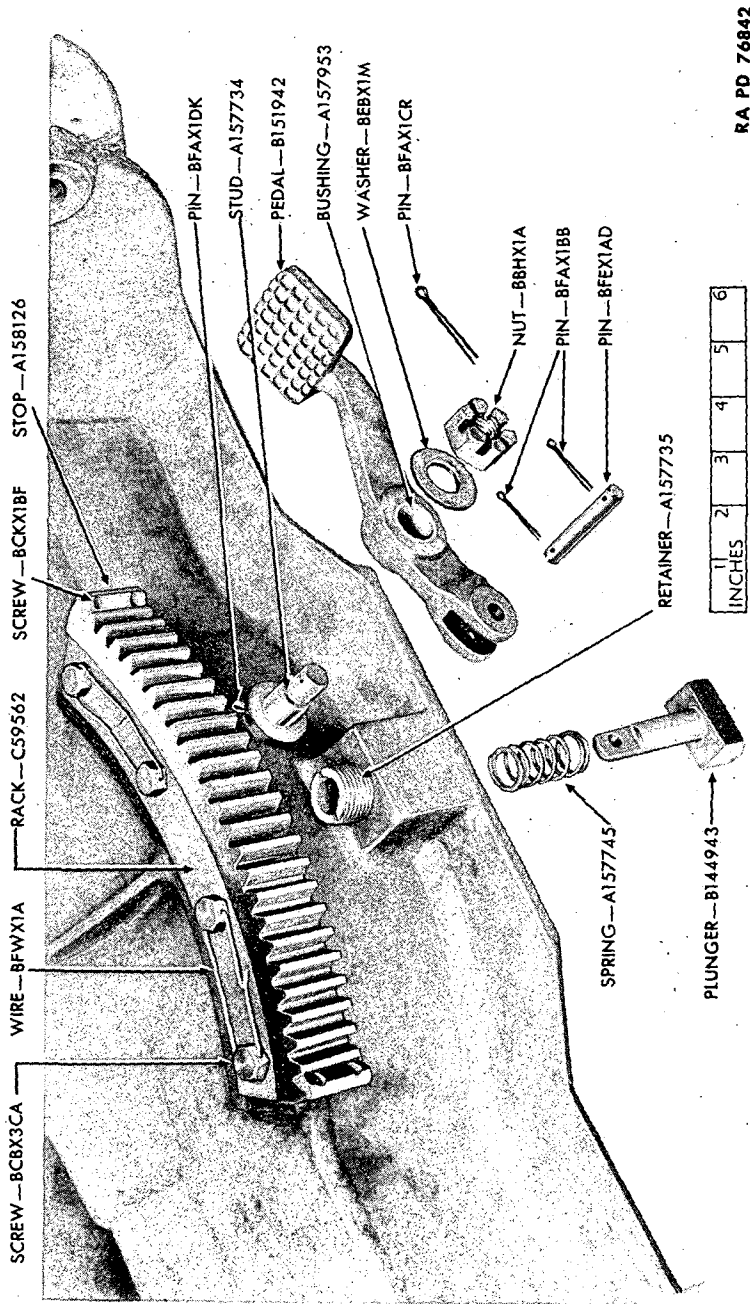

RA PD 76842

| | | | | | |
|--------|---|---|---|---|---|
| 1 | 2 | 3 | 4 | 5 | 6 |
| INCHES | | | | | |

Figure 140—Traversing Rack and Firing Base Lock

ORDNANCE MAINTENANCE
75-MM HOWITZERS AND CARRIAGES

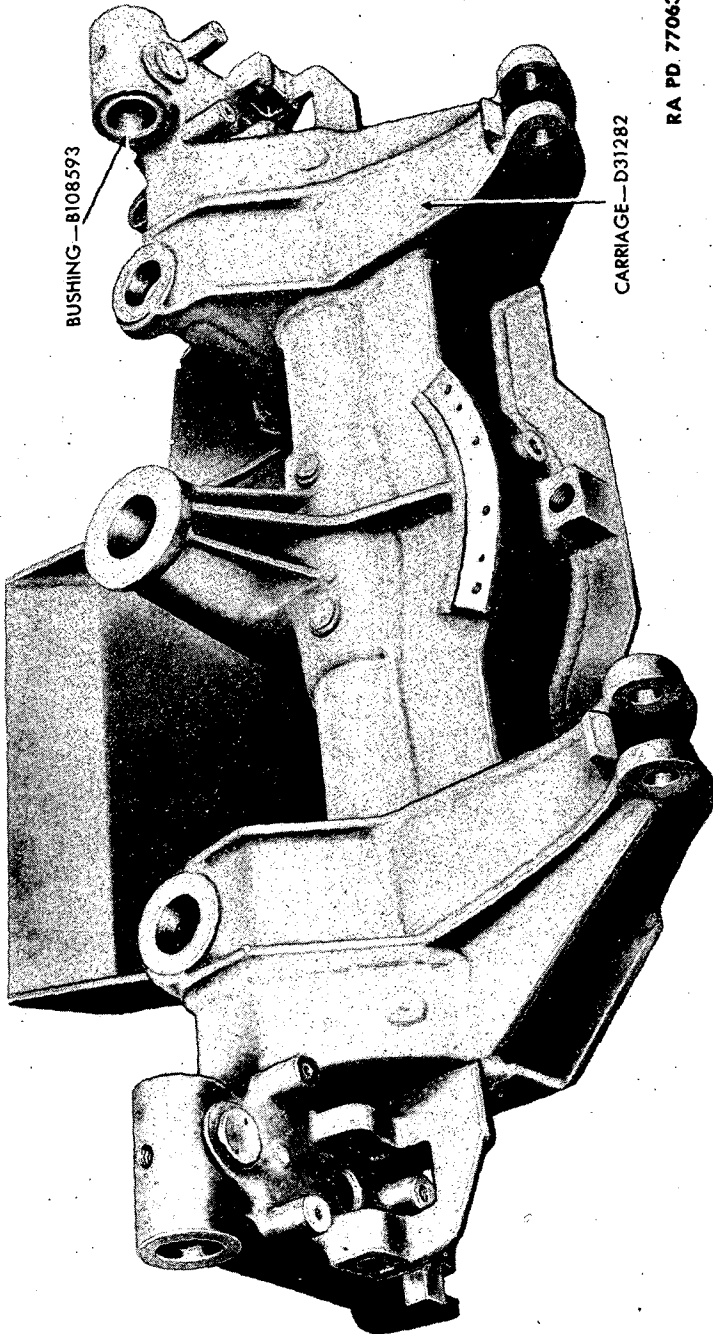

RA PD. 77063

Figure 141—Bottom Carriage Assembly

MAINTENANCE OF FIELD HOWITZER CARRIAGE M3A3

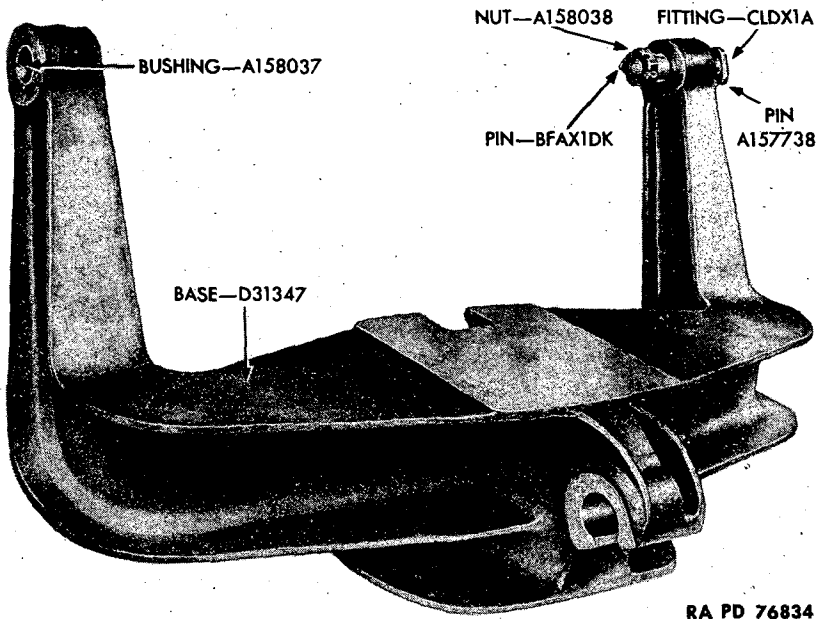

RA PD 76834

Figure 142—Firing Base Assembly

- (b) Secure in place with four screws and two pieces of safety wire.
- (2) ASSEMBLE FIRING BASE LOCK (figs. 138, 140, and 141).
- (a) If removed, screw the retainer A157735 in place in the bottom carriage.
- (b) Slide the pedal in place on the stud. Put the washer and nut on the stud and secure nut with cotter pin.
- (c) Slide the spring on the plunger and insert spring and plunger in place in bottom carriage. Attach the plunger to the pedal with the straight pin and two cotter pins. *NOTE: Be sure the beveled edge of the plunger is toward the front of bottom carriage.*
- (3) ASSEMBLE WHEEL CARRIER LATCH (figs. 138 and 139).
- (a) Insert the plunger spring in the latch lever handle, then insert the plunger. Push in on plunger and insert the rack A161603.
- (b) Place the lever and rack in position on the bottom carriage and secure rack with two washers and screws.
- (c) Insert the latch bolt in place in the slots in the bottom carriage, making certain to get rounded end of the bolt toward the inside and down.
- (d) Insert the two screws A161601, one in the lever handle and bottom carriage, the other in the lever handle and bolt. Check the latch for operation.

**ORDNANCE MAINTENANCE
75-MM HOWITZERS AND CARRIAGES**

(e) Repeat the above operations to assemble and install the other latch.

(4) **INSTALL FIRING BASE** (figs. 137, 141, and 142).

(a) Place the firing base in the firing position and lift the bottom carriage into place on the firing base. Lock the firing base to the bottom carriage by means of the firing base lock.

(b) Line up the arms of the firing base with the firing base hinge pin brackets on the bottom carriage. Drive the hinge pins into place in firing base and bottom carriage from the outside (fig. 137). Secure with nuts and cotter pins.

(5) **INSTALL TRAILS** (figs. 133 and 134).

(a) While one man holds the bottom carriage steady, two additional men will lift trail and insert the front end in place in the trail bracket of the bottom carriage. It may be necessary to strike the rear end of trail in order to get it into position.

(b) Line up trail hinge pin holes in bottom carriage and trail. Insert trail hinge pin from top. Secure trail hinge pin with nut and cotter pin. Use pintle and trail wrench B108514 to tighten nut.

(c) Repeat above operations to install the other trail.

(d) Swing trails until they are parallel.

(6) **INSTALL WHEEL CARRIER** (figs. 133 and 134).

(a) Slide the wheel carrier pin in place in the bottom carriage. Place bronze washer A140573 and lock washer A169401 on the carrier pin. Screw the nut on and secure with cotter pin.

(b) Drive wheel spindle in place in the wheel carrier and secure with nut and cotter pin.

(c) Repeat above operations to install the other wheel carrier.

(d) Swing wheel carriers to the firing position and lock.

(7) **INSTALL BRAKE MECHANISM** (figs. 131 and 132).

(a) Fasten the brake housing in place on the wheel carrier with six screws, washers, and nuts (fig. 131).

(b) Tap the brake cam shaft in place in the brake housing plate and hand brake lever hub, while holding the lever in line with the cam shaft hole in plate and carrier. Make sure cam shaft is all the way in.

(c) Secure brake rack to carrier with two screws and washers.

(d) Insert screw in hand brake lever clamp. Tighten nut and secure with cotter pin.

(e) Place the brake cam in position in the brake cam shaft (fig. 131). Insert brake shoe links of the two brake shoe assemblies in place in the brake wedge housing. Install the long brake shoe retracting

MAINTENANCE OF FIELD HOWITZER CARRIAGE M3A3

spring in place on the brake shoe assemblies. Pull the lower brake shoe up so that the roller engages the cam. Install the lower short brake shoe retracting spring. Install the upper short spring, lift up on shoe and place roller in engaged position with cam.

- (f) Repeat above operations to install the other brake mechanism.
- (8) **MOUNT WHEEL HUB AND DRUM.**
- (a) Make certain that the inner roller bearing and retainer are in place in the wheel hub.
- (b) Lift hub and drum into place on the wheel spindle.
- (c) Place the outer bearing cone and roller in place in the hub and on spindle. Follow with spindle outer washer. Screw spindle nut in place and adjust bearing by tightening nut until bearings bind, then back off until wheel turns freely with no end play. Secure spindle nut with cotter pin and screw hub cap in place.
- (d) Lift the wheel and tire assembly in place on wheel studs and secure with five conical-shaped wheel stud nuts. Use wrench C59566 and handle B108566 to tighten nuts.
- (e) Repeat above operations to mount the other wheel hub and wheel.
- (9) Place the wheels in the traveling position.
- (10) Assemble the remainder of the carriage and howitzer as outlined in paragraph 38 d.

41. WHEELS AND BRAKE MECHANISM.**a. General.**

(1) The M3A3 Carriage is equipped with combat tires and divided rims. Each wheel consists of a steel disk, divided rims, pneumatic combat tire, beadlock, puncture-sealing or bullet-sealing inner tube and a tire lock ring. The wheels rotate on inner and outer anti-friction roller bearings (fig. 143).

(2) The brake mechanism is the internal expanding type. The brake shoes are actuated by the hand brake lever attached to the brake cam shaft. Movement of the brake lever forces the brake cam against the brake cam rollers of the brake shoes. This causes the shoes to expand outward against the inner surface of the brake drum which is rigidly fastened to each wheel. When the brake lever is placed in the "off" position, the brake shoes are pulled away from the drum by the brake shoe retracting springs (fig. 144).

(3) Movement of the hand brake lever is controlled by the brake ratchet plunger engaging teeth of the brake ratchet rack. The brake shoes are adjusted for wear by means of the brake adjusting wedge (fig. 144).

ORDNANCE MAINTENANCE
75-MM HOWITZERS AND CARRIAGES

RA PD 76840

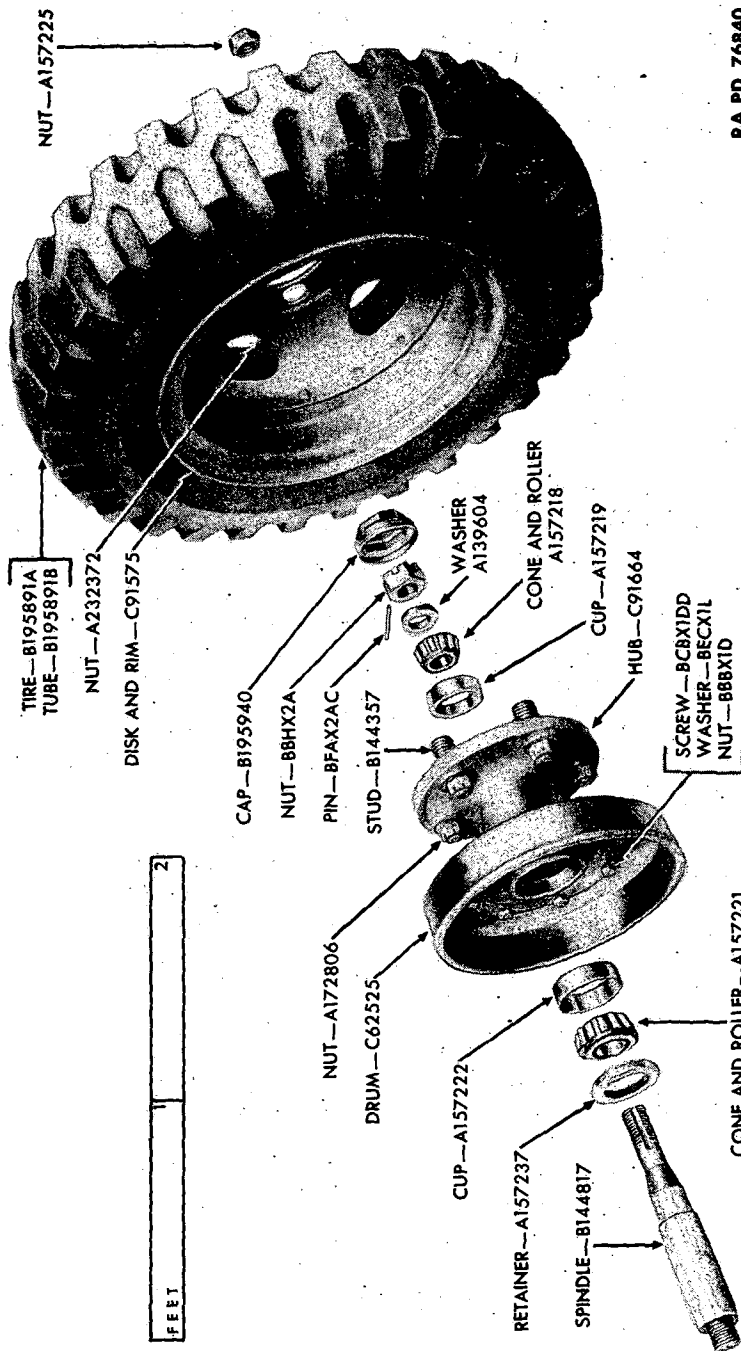
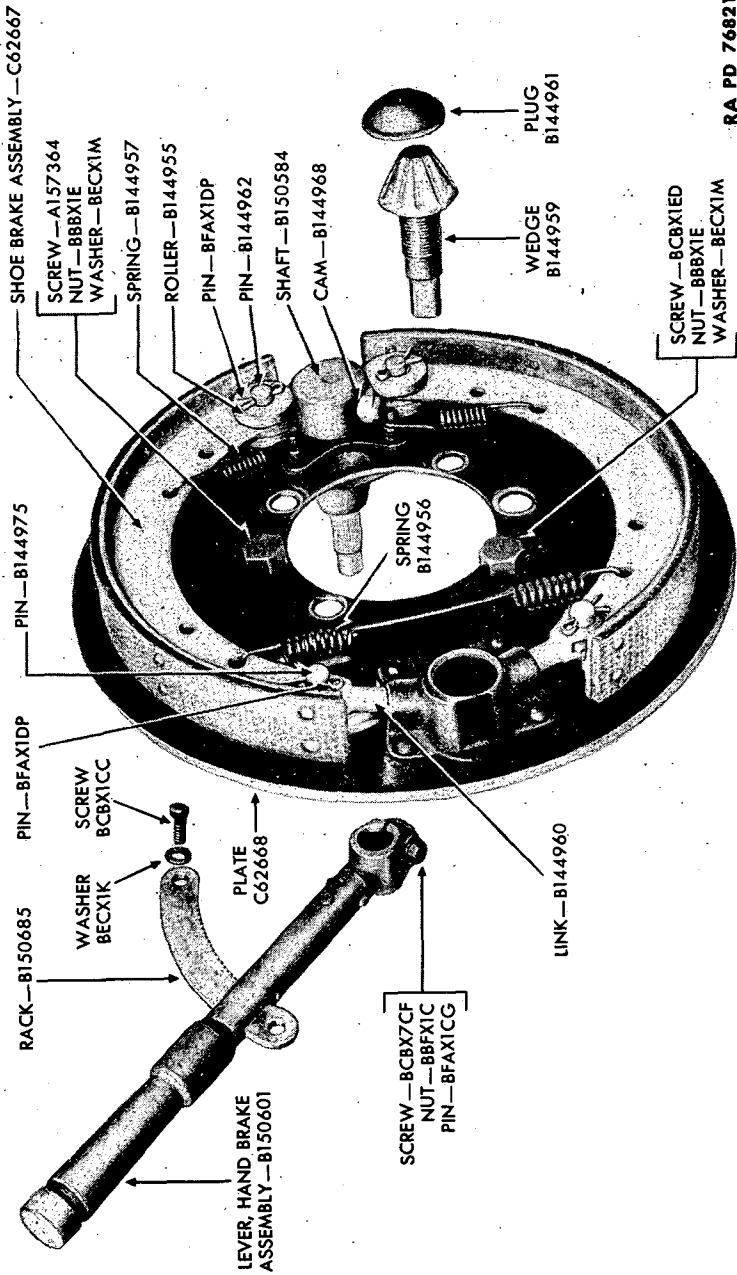

Figure 143—M3A3 Carriage Wheel Group

MAINTENANCE OF FIELD HOWITZER CARRIAGE M3A3



RA PD 76821

Figure 144—Brake Mechanism

ORDNANCE MAINTENANCE
75-MM HOWITZERS AND CARRIAGES

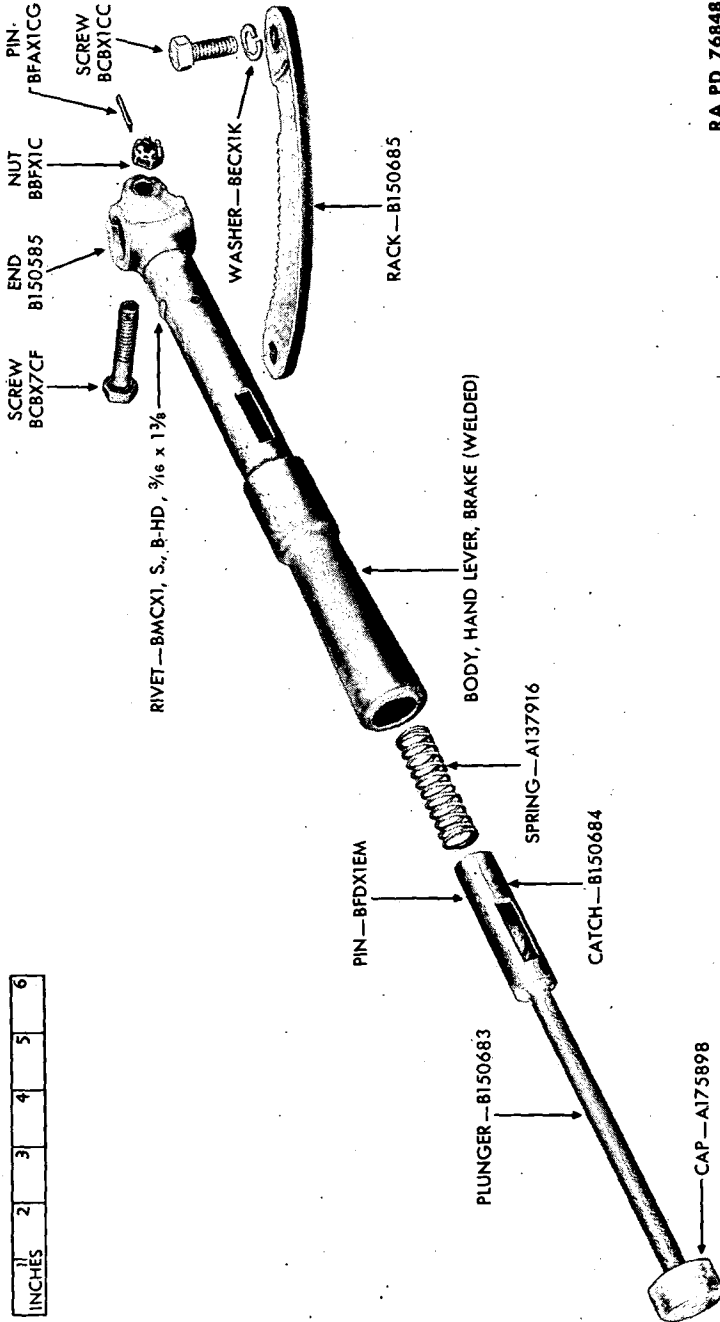

| | | | | | |
|--------|---|---|---|---|---|
| 1 | 2 | 3 | 4 | 5 | 6 |
| INCHES | | | | | |

RA PD 76848

Figure 145—Hand Brake Lever—Exploded View

MAINTENANCE OF FIELD HOWITZER CARRIAGE M3A3**b. Removal and Disassembly.**

NOTE: Removal and disassembly is practically completed when the carriage is disassembled to remove bottom carriage. This is covered in paragraph 40 b.

(1) REMOVE WHEEL BEARING CUPS.

(a) The outer cups or races of the roller bearings can be removed from the wheel hub by driving them out with a drift and hammer.

(b) To remove the inner bearing cup, it will be necessary to first remove the retainer and then the cone and roller.

(2) DISASSEMBLY OF HAND BRAKE LEVER (fig. 145).

(a) Press down on plunger and remove the rack.

(b) Plunger and rack are now free to be removed.

(3) **REMOVE BRAKE SHOE ADJUSTING WEDGE (fig. 144).** Screw the brake shoe adjusting wedge against the adjusting wedge plug and continue screwing the wedge until the plug is pushed out and the wedge is removed.

c. Repairs (figs. 143 and 144).

(1) Clean all parts of the wheel group and brake mechanism thoroughly.

(2) Examine all parts carefully for cracks, wear, or breakage.

(3) Replace all worn or damaged parts.

d. Assembly and Installation.**(1) INSTALL BRAKE SHOE ADJUSTING WEDGE (fig. 144).**

(a) Screw the wedge into position in the brake housing plate with the cone of wedge facing outward.

(b) Tap the wedge plug into place. Make certain that the plug is flattened enough to stay in place.

(2) INSTALL WHEEL BEARING CUPS (fig. 143).

(a) The wheel bearing cups are driven into place against the shoulder in the hub with a drift and hammer. Strike the cup all around the edge to get in straight and true.

(b) Place the inner cone and roller and retainer in place in the hub.

42. TRAILS.**a. General.**

(1) The right and left trails (fig. 146) are tapered, box construction welded steel members attached to the bottom carriage by means of trail hinge pins and nuts (fig. 148). The trail hinge pins permit the trails to be pivoted in order to place the trails in the firing or traveling position.

ORDNANCE MAINTENANCE
75-MM HOWITZERS AND CARRIAGES

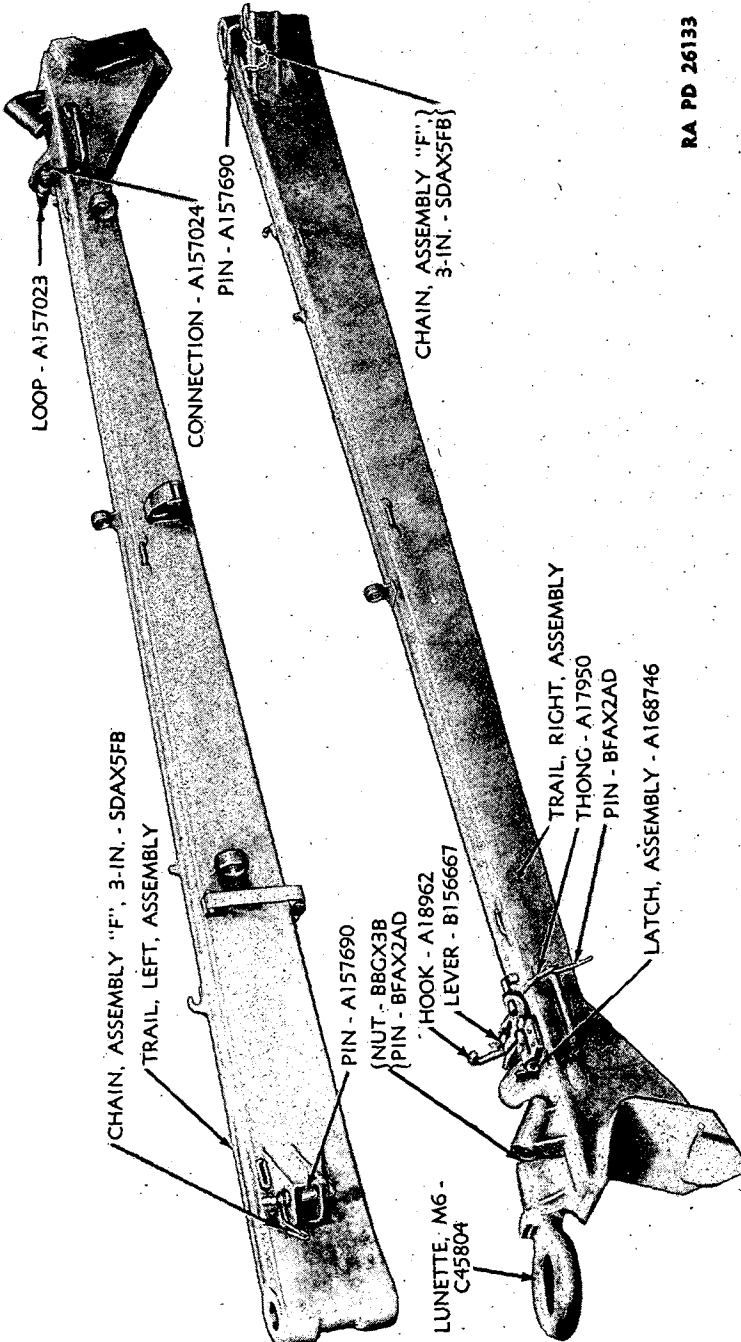

RA PD 26133

Figure 146—75-mm Howitzer Carriage M3A2 and M3A3—Left and Right Trail Assemblies

MAINTENANCE OF FIELD HOWITZER CARRIAGE M3A3

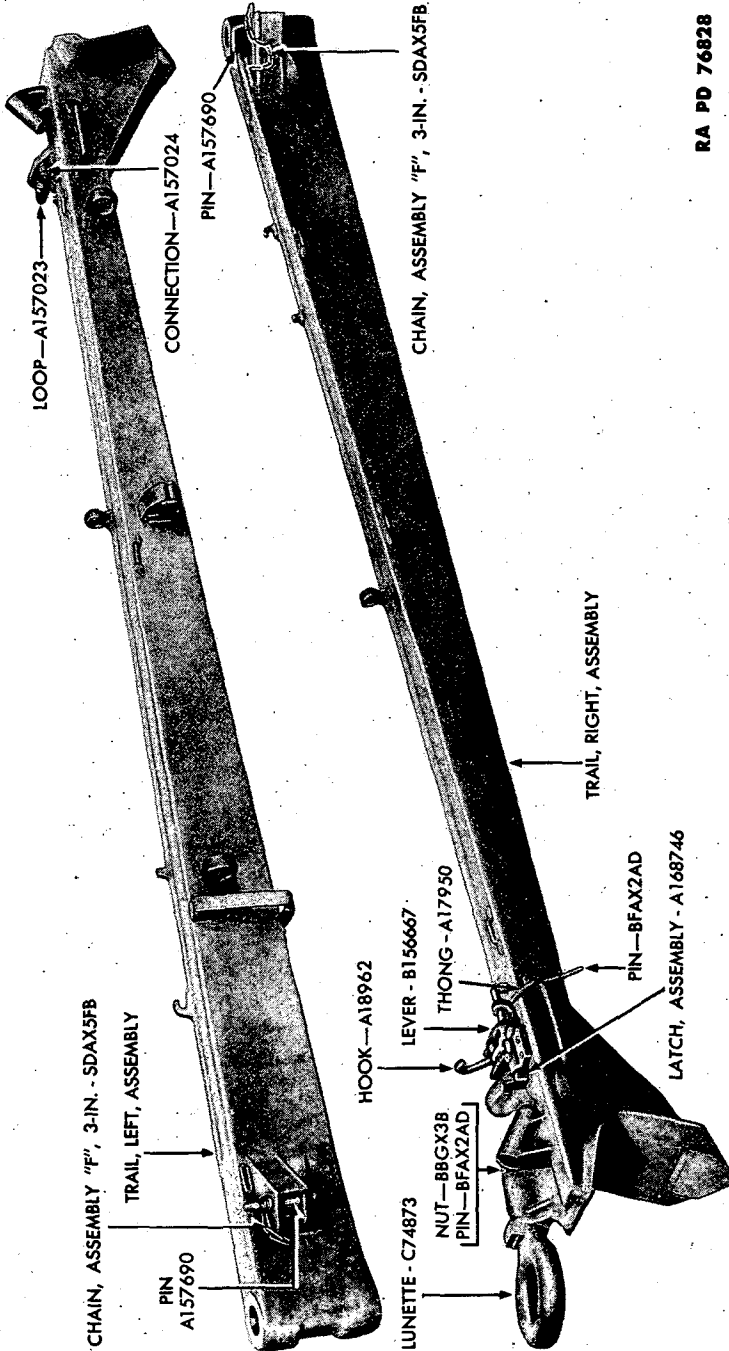

RA PD 76828

Figure 147—Right and Left Trail Assembly With Standard Lunette

**ORDNANCE MAINTENANCE
75-MM HOWITZERS AND CARRIAGES**

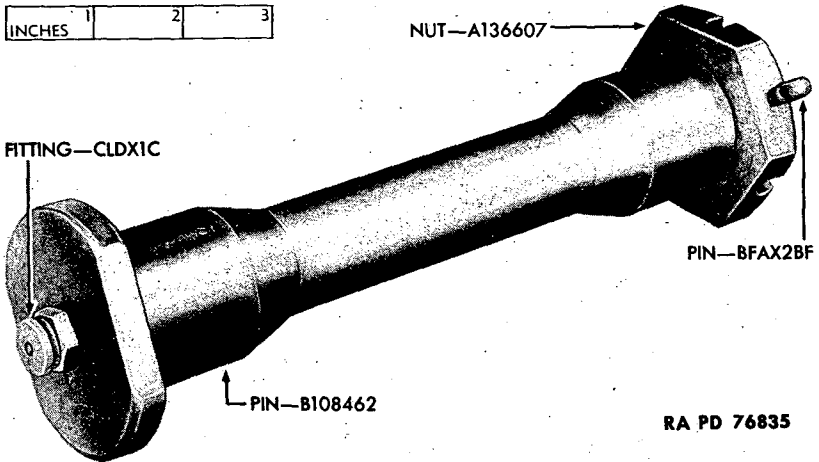

Figure 148—Trail Hinge Pin

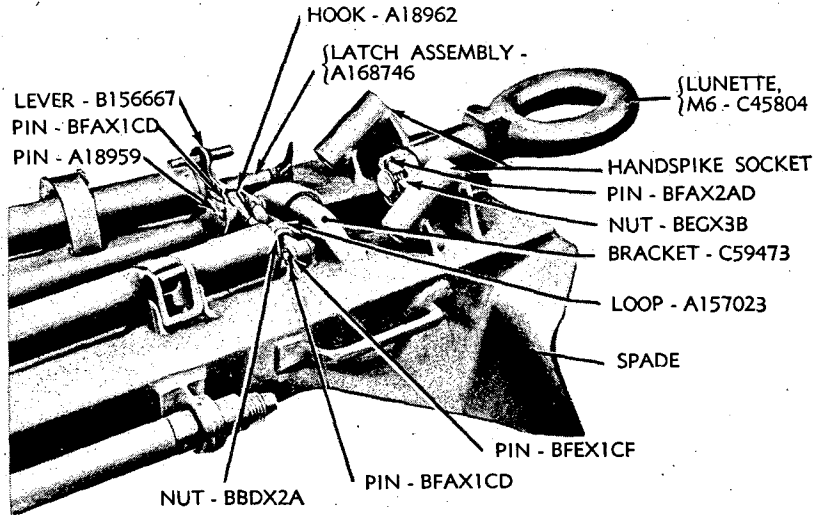
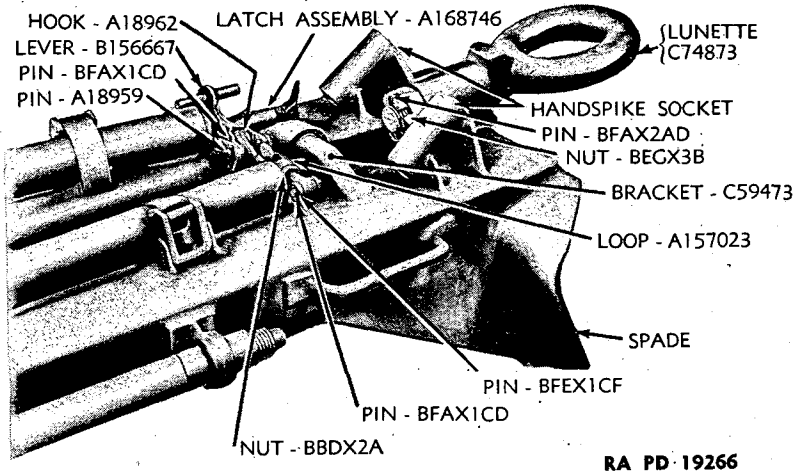

Figure 149—Trail Lock Group

(2) When spread to their full open position, the trails are locked by means of trail lock pins. The pins are inserted in the trail lock pin brackets of the trail and through mating holes in the bottom carriage brackets.

(3) When the trails are closed to their traveling position, they are locked together by means of a toggle mechanism (fig. 149). In

MAINTENANCE OF FIELD HOWITZER CARRIAGE M3A3



RA PD 19266

Figure 150—Trail Lock Group With Standard Lunette

the operation of locking the trails together, the trail lock hook, which is connected to the trail lock lever on the right trail, is inserted into the trail lock loop assembled to the left trail. When the trail lock lever is pressed down, it draws the two trails together and the ball bracket seats in the socket bracket. Then, by inserting a large cotter pin through the lock lever and connection bracket, the trails are locked in the traveling position.

(4) A handspike socket bracket is welded to the top of each trail at the rear. A lunette is assembled to the rear of the right trail.

b. Removal and Disassembly.

- (1) Removal of trails is described in paragraph 40 b.
- (2) REMOVE LUNETTE.
 - (a) Remove the cotter pin and nut from the lunette.
 - (b) Tap the lunette out of the trail bracket.
- (3) DISASSEMBLE TRAIL LOCK. The entire trail lock can be removed from trails by removing cotter pins and straight pins (fig. 149).

c. Repairs.

- (1) Clean all parts of trails thoroughly.
- (2) Examine all parts carefully for cracks, wear, or breakage.
- (3) Replace all worn or damaged parts.

d. Assembly and Installation.

- (1) ASSEMBLY TRAIL LOCK (fig. 149).
 - (a) Place the trail lock loop and connection in place on the left trail and secure with a straight pin and two cotter pins.
 - (b) Assemble the trail hook and lever to the right trail with proper pins and cotter pins.

**ORDNANCE MAINTENANCE
75-MM HOWITZERS AND CARRIAGES**

- (2) **INSTALL LUNETTE** (fig. 149).
 - (a) Drive the lunette into place in the bracket on the right trail.
 - (b) Screw nut on and secure with cotter pin.
- (3) **TYPES OF LUNETTES.** If carriage is equipped with standard lunette, (fig. 150) fold the lunette forward. If earlier type lunette (fig. 149) is being used, remove lunette from rear trail prior to firing.
- (4) **INSTALL TRAILS.** Installation of trails is covered in subparagraph d, above.

**Section X
LUBRICATION****43. LUBRICATION INSTRUCTIONS.**

a. Refer to War Department Lubrication Orders Nos. 63, 76, and 144 (TM 9-319 and TM 9-320) for lubrication which may be done by the using arms. Lubrication which may be done only by Ordnance maintenance personnel is described below:

(1) **AXLE SLEEVE.** Every 6 months, remove, clean axle and inside sleeve and repack cavity between axle and inner housing with O.D. grease No. 0 above +32°F, No. 00 below +32°F.

(2) **TRAVERSING MECHANISM.** Every 6 months, disassemble and wash all parts. Pack handwheel ball bearing, traversing balls, and races with O.D. grease No. 0 above +32°F, No. 00 below +32°F.

(3) **UPPER AND LOWER ELEVATING GEAR CASES.** Every 6 months, disassemble and wash all parts. Pack bearing and coat gear teeth. Repack cases two-thirds full with O.D. grease No. 0 above +32°F, No. 00 below +32°F, and reassemble.

(4) **ELEVATING AND TRAVERSING GEAR CASES.** Before changing grades of lubricant, completely disassemble and clean all parts. Repack bearings, reassemble and fill case two-thirds full with O.D. grease, No. 0 above +32°F, No. 00 below +32°F.

(5) **EQUILIBRATORS.** Every 6 months, disassemble and clean springs and inside of cylinder. Coat springs and inside of cylinder with O.D. grease No. 0 above +32°F, No. 00 below +32°F, and reassemble.

(6) **TRAVERSING MECHANISM.** Every 6 months, disassemble and wash all parts with dry-cleaning solvent. When thoroughly dry, pack handwheel ball bearing, traversing balls, and races with O.D. grease No. 0 above +32°F, No. 00 below +32°F.

(7) **UPPER AND LOWER ELEVATING GEAR CASES.** Before changing grades of lubricant, disassemble and wash all parts with dry-cleaning solvent. Dry thoroughly, reassemble and pack cases three-fourths full with O.D. grease No. 0 above +32°F, No. 00 below +32°F.

Section XI

REFERENCES

44. PUBLICATIONS INDEXES.

The following publications indexes should be consulted frequently for latest changes or revisions of references given in this section and for new publications relating to materiel covered in this manual:

- a. Introduction to Ordnance Catalog (explaining SNL System) ASF Cat.
ORD 1 IOC
- b. Ordnance Publications for Supply Index (index to SNL's) ASF Cat.
ORD 2 OPSI
- c. Index to Ordnance Publications (listing FM's, TM's, TC's, and TB's of interest to Ordnance personnel, OPSR, MWO's, BSD, S of SR's, OSSC's, and OFSB's and including alphabetical listing of Ordnance major items with publications pertaining thereto) OFSB 1-1
- d. List of Publications for Training (listing MR's, MTP's, T/BA's, T/A's, FM's, TM's, TR's, TB's, SB's, MWO's, WDLO's and Firing Tables) FM 21-6
- e. List of Training Films, Film Strips, and Film Bulletins (listing TF's, FS's, and FB's by serial number and subject) FM 21-7
- f. Military Training Aids (listing graphic training aids, models, devices, and displays) FM 21-8

45. STANDARD NOMENCLATURE LISTS.

- a. **Ammunition.**
 - Ammunition, blank, for pack, light and medium field, tank, and antitank artillery SNL R-5
 - Ammunition, fixed and semifixed, including subcaliber, for pack, light and medium field, aircraft, tank, and antitank artillery, including complete round data ORD 11
SNL R-1
 - Ammunition instruction material for pack, light and medium field, aircraft, tank and antitank artillery ORD 11
SNL R-6
- b. **Cleaning Material.**
 - Cleaning, preserving and lubricating materials; recoil fluids, special oils, and miscellaneous related items ORD 5
SNL K-1

**ORDNANCE MAINTENANCE
75-MM HOWITZERS AND CARRIAGES**

| | |
|---|------------------|
| Soldering, brazing and welding material, gases and related items | SNL K-2 |
| c. Howitzer Materiel. | |
| Howitzer, pack, 75-mm, M1 and M1A1 | SNL C-20 |
| Howitzer, pack, 75-mm, M1 and M1A1; and Carriage howitzer, 75-mm, M2A1, M3, M3A2, and M3A3 | SNL C-26 |
| Howitzer, pack, 75-mm, M1A1; and Carriage, howitzer, 75-mm, M8 | SNL C-54 |
| Major items of pack, light and medium field artillery; and armament of these calibers for airplane and combat vehicles | ORD 3 SNL C-1 |
| Tools, maintenance, for repair of pack, light and medium field artillery; and armament of these calibers for airplane and combat vehicles | SNL C-18 |
| d. Sighting Equipment. | |
| Mount, telescope, M3 (for 75-mm pack howitzer carriage M1); and Telescope, panoramic, M1—parts and equipment | SNL F-106 |
| Mount, telescope, M17; Quadrant, range, M2; Telescope, elbow, M4; Mount, telescope, M16; and Quadrant, range, M3 | SNL F-169 |
| 46. EXPLANATORY PUBLICATIONS. | |
| a. Chemical Attack. | |
| Decontamination | TM 3-220 |
| Defense against chemical attack | FM 21-40 |
| b. Cleaning, Preserving, and Lubricating. | |
| Artillery, lubrication, general | OFSB 6-4 |
| Cleaning, preserving, lubricating, and welding materials and similar items issued by the Ordnance Department | TM 9-850 |
| Cold weather lubrication and service of artillery materiel | OFSB 6-5 |
| General instructions for recoil fluid, light and medium artillery (37-mm to 240-mm, inclusive) | OFSB 6-6 |
| Maintenance: General | OFSB 4-1 |

REFERENCES

- c. **Howitzer Materiel.**
 - 75-mm howitzer materiel TM 9-320
 - 75-mm pack howitzer M1A1 and carriage M8 TM 9-319
- d. **Ordnance Maintenance.**
 - Maintenance and care of pneumatic tires and rubber treads TM 31-200
 - Ordnance Maintenance: Fuze setters M14, M15, M16, M17, and T35 TM 9-1591
 - Ordnance Maintenance: Inspection of ordnance materiel TM 9-1100
 - Ordnance Maintenance: Mount, telescope, M16; quadrant range M3; and telescope, elbow, M5 TM 9-1547
 - Ordnance Maintenance: Panoramic telescope M1 and telescope mount M3 TM 9-1548
 - Ordnance Maintenance: Range finders, 1-meter base and 80-cm base, all types TM 9-1585
 - Star-gaging equipment, impression outfits and pressure gages TM 9-1860

INDEX

| E—contd. | Page | E—contd. | Page |
|--|-------------|---|-------------|
| Equilibrators (carriage M1 and M8) | | Howitzers and carriages | |
| description | 81 | assembly of subassemblies | 52 |
| disassembly, assembly, installation, and repairs | 84 | inspection instructions | 22 |
| removal and disassembly | 84 | maintenance and repair | 52 |
| Equilibrators (carriage M3A3) | | ordnance maintenance data | 16 |
| description | 118 | tools and equipment for inspection | 17 |
| removal and disassembly | 119 | | |
| repairs, assembly, and installation | 122 | L | |
| Equilibrators (howitzer and carriage), inspection instructions | 26 | Lifting eye, damaged | 56 |
| Eyebolt, damaged | 58 | Lubrication | |
| | | inspection | 27 |
| F | | instructions | 172 |
| Filling valve, failure | 67 | Lunette | |
| Firing base | | installation and types of | 172 |
| installation | 162 | removal | 171 |
| removal | 154 | | |
| Firing base lock | | M | |
| assembly | 161 | Maintenance and repair | 52 |
| disassembly | 158 | Manometer test | 36 |
| Firing lock M13 | 62 | | |
| Floating piston, determining friction of | 40 | N | |
| | | Nitrogen pressure | |
| G | | inspection | 37, 40 |
| Gage, pressure | 17 | to correct for temperature variation | 41 |
| Gage, pressure, master B748A | 21 | | |
| Gaskets A174909, A174896, and 174903 | 21 | O | |
| | | Oil index | |
| H | | sticking | 65 |
| Hand brake lever | | testing | 36 |
| description | 163 | Oil leakage | 36, 67 |
| disassembly | 167 | Oil reserve, inspection | 36 |
| removal | 153 | | |
| Handwheel, assembly | 105 | P | |
| Handwheel shaft bracket (carriage M3A3) | 142 | Pastilles, effect upon safety | 29 |
| Howitzers | | Piston rod latch | 128 |
| characteristics | 1 | Pressure gage (See Gage, pressure) | |
| data | 7 | | |
| differences among models | 1 | R | |
| imperfections in return to battery maintenance | 66 | Recoil cylinder front and head follower, adjustment | 69 |
| parts to be inspected | 23 | Recoil indicator, damaged | 71 |
| | | Recoil mechanism | |
| | | assembly and installation | 71 |
| | | inspection | 23, 29 |
| | | maintenance | 62 |
| | | Recoil piston | |
| | | adjustment of packing | 69 |
| | | to determine friction of | 42 |

ORDNANCE MAINTENANCE 75-MM HOWITZERS AND CARRIAGES

| R—contd. | Page | | Page |
|--------------------------------------|------|---|--------|
| Respirator, faulty | 67 | Trails | |
| Rifling, deformation of | 29 | assembly | |
| Rocker assembly (carriage M1 and M8) | | carriage M3A3 | 171 |
| disassembly | 88 | carriages M1 and M8 | 162 |
| installation | 99 | description | |
| Rocker pinion shaft | | carriage M3A3 | 167 |
| removal and disassembly | 93 | carriages M1 and M8 | 106 |
| repairs | 95 | inspection instructions | 26 |
| Rockers, assembly of | 98 | installation | |
| | | carriage M3A3 | 162 |
| | | carriages M1 and M8 | 106 |
| | | removal, disassembly, and repairs | |
| | | carriage M3A3 | 171 |
| | | carriages M1 and M8 | 106 |
| S | | Traversing gear case | 132 |
| Scope of manual | 1 | Traversing mechanism (carriage M3A3) | |
| Set, gage hand, A174850, use | 22 | description, removal, and disassembly | 128 |
| Shield (carriage M3A3) | | inspection instructions | 25 |
| removal and disassembly | 114 | repairs, assembly, and installation | 133 |
| repairs, assembly, installation | 118 | Traversing mechanism and axle (carriages M1 and M8) | |
| Sight bracket | | description | 99 |
| assembly | | disassembly | 101 |
| carriage M3A3 | 128 | removal and disassembly | 99 |
| carriages M1 and M8 | 80 | repairs, assembly, and installation | 105 |
| disassembly | | Traversing rack | 158 |
| carriages M1 and M8 | 78 | Tube | |
| Star-gaging | 28 | average life of | 28 |
| Studs, damaged | 58 | inspection | 23, 28 |
| | | maintenance | 53 |
| | | removal, disassembly, and repairs | 56 |
| | | W | |
| | | Wheels | |
| | | description | |
| | | carriage M1 | 106 |
| | | carriage M8 | 109 |
| | | carriage M3A3 | 163 |
| | | | |
| Top carriage | | | |
| description, removal and disassembly | 134 | | |
| inspection instructions | 26 | | |
| repairs, assembly, and installation | 138 | | |
| Top sleigh | | | |
| general description | 72 | | |
| inspection | 24 | | |
| removal, disassembly, and repairs | 73 | | |

INDEX

| W—contd. | Page | | Page |
|-------------------------|-------------|-------------------------------------|-------------|
| Wheels—contd. | | repairs, assembly, and installation | |
| disassembly | | carriage M3A3 | 167 |
| carriage M1 | 109 | carriages M1 and M8 | 113 |
| carriage M8 | 113 | Wheel carrier | |
| carriage M3A3 | 167 | installation | 162 |
| inspection instructions | 27 | removal | 153 |
| removal | | Wheel carrier latch, assembly | 161 |
| carriage M3A3 | 167 | Wheel spindle, removal | 153 |
| carriages M1 and M8 | 109 | | |