

TM 5-1088

WAR DEPARTMENT TECHNICAL MANUAL

PLOW, BOTTOM AND DISC TOWED -TYPE FOUR 14-INCH BOTTOMS DEERE MODEL 7

This is a reprint of TM 5-1088, Maintenance Manual and Parts Catalog, Plow, Tractor, Heavy Duty, 4 14-in. Bottoms, Model No. 7, Deere & Co., 29 January 1943. No distribution will be made to personnel possessing the original publication.

WAR DEPARTMENT TECHNICAL MANUAL
TM 5-1088

PLOW, BOTTOM AND
DISC TOWED-TYPE
FOUR 14-INCH BOTTOMS
DEERE MODEL 7



WAR DEPARTMENT

JANUARY 1943

INDEX

	<i>Page Nos.</i>	<i>Paragraph</i>
SECTION I—INTRODUCTION.....	1	
SECTION II—DESCRIPTION AND CHARACTERISTICS.....	4-5	
Axles.....	4	1
Beams.....	4	1
Bottoms.....	4	1
Connecting Bar.....	5	1
General Description.....	4	1
Hitch.....	4	1
Identification.....	4	1
Levers.....	4	1
Lifting Springs.....	4	1
Mobility.....	4	1
Power Lift.....	4	1
Rolling Coulters.....	4	1
Shipping Packages.....	5	1
Specifications.....	5	1
PART 1, SECTION III—SETTING UP INSTRUCTIONS		
Alemite Fittings.....	12	14
Axles, Furrow.....	6	2
Axle, Land.....	7	4
Axle, Rear.....	9	7
Beam.....	6	2
Bottoms.....	10	10
Check and Lubricate.....	12	15
Connecting Bar.....	9	8
Coulters.....	11	11
General.....	6	1
Hitch.....	11	12
Lever, Furrow.....	8	6
Lever, Master.....	8	5
Lubrication.....	12	15
Power Lift.....	7	4
Removing Varnish.....	12	16
Rope.....	11	13
Spring Release.....	11	12
Springs, Lifting.....	10	9
Wheel, Furrow.....	6	3
Wheel, Land.....	7	4
Wheel, Rear.....	9	7
PART I, SECTION IV—OPERATING INSTRUCTIONS, ADJUSTMENT AND CONTROLS		
Controls.....	13-18	1
Coulters.....	17	1
Depth Adjustments.....	16	1
Hitch.....	13	1
Hitch Adjustments—Horizontal.....	13	1
Hitch Adjustments—Vertical.....	13	1
Levers.....	15	1
Lifting Springs.....	17	1
Opening up the Land.....	13	1
Rear Wheel.....	18	1
Spring Release Hitch.....	14	1
Trip Rope.....	15	1
PART II, SECTION I—MAINTENANCE MANUAL		
Adjusting the Clutch.....	20	7
Coulter Bearings.....	19	5
Hardening Soft Center Steel Shares.....	19	3
Lubrication Instructions.....	21	8
Plow Bottoms and Coulters.....	19	1
Sharpening the Coulter Blade.....	19	4
Sharpening the Share.....	19	2
Wheel Bearings.....	19	6
PART III—SPARE PARTS LIST.....	23	

INDEX TO ILLUSTRATIONS

PART I—Operator's Manual

	<i>Page Nos.</i>	<i>Figure No.</i>
Adjusting Levers.....	5	21
Adjusting Lifting Springs.....	17	26
Adjustment for Medium or Deep Plowing.....	16	24
Adjustment for Shallow Plowing.....	16	25
Alemite Fittings.....	12	16
Assembling Furrow Axle.....	6	3
Assembling Furrow Wheel.....	7	4
Assembling Land Axle, Wheel and Power Lift.....	7	5
Assembling Rear Wheel.....	9	9
Attaching Bottoms.....	10	12
Attaching Furrow Lever.....	8	7
Attaching Master Lever.....	8	6
Attaching Rear Axle and Wheel.....	9	8
Attaching Rolling Coulters.....	11	13
Connecting Bar.....	9	10
Clevis Jaw Adjustment.....	14	18
Clutch Rope.....	11	15
Hitch Adjustments.....	13	17
Hitch and Spring Release.....	11	14
Improper Setting of Rolling Coulters.....	17	30
Landside View—John Deere No. 7 Tractor Plow.....	3	2
Lateral Adjustment of Rear Wheel.....	18	32
Lateral Adjustment of Rolling Coulters.....	17	27
Lever Adjustment for Deep Plowing.....	15	22
Lever Adjustment for Shallow Plowing.....	16	23
Lifting Springs.....	10	11
Moldboard View.....	2	1
Proper Setting of Rolling Coulters.....	17	29
Rolling Coulters Details.....	17	28
Spring Release Hitch—Closed.....	14	19
Spring Release Hitch—Released.....	14	20
Up and Down Adjustment of Rear Wheel.....	18	31

PART II—Maintenance Manual

Clutch Assembled and Disassembled.....	20	33
Lubrication Chart.....	21	34

PART III—Spare Parts List

Beams and Braces.....	24	35
Connecting Bar.....	29	41
Furrow Wheel and Axle.....	25	36
Hitch and Spring Release.....	31	43
Land Wheel, Axle and Power Lift.....	26	37
Lever and Lifting Springs.....	27	38
Lifting Clutch.....	30	42
Plow Bottoms.....	32	44
Rear Axle.....	28	39
Rear Wheel.....	29	40
Rolling Coulters.....	33	45
Tools.....	34	46

SECTION I

Introduction

1. **PURPOSE AND SCOPE.**—These instructions are published for the information and guidance of the using arms charged with the operation, maintenance and repair of this material. They contain descriptions of the major units and their function in relation to the other components of the plow, as well as instructions for operation, inspection and maintenance.

2. Any reference to "Right" and "Left", "Front" and "Rear" refer to the operator's "Right" and "Left", "Front" and "Rear" when facing in the same direction the plow will face when being used.

In the case of this particular model of plow, "Right" side is often referred to as "Moldboard" or "Furrow" side, and "Left" side as "Land-side".

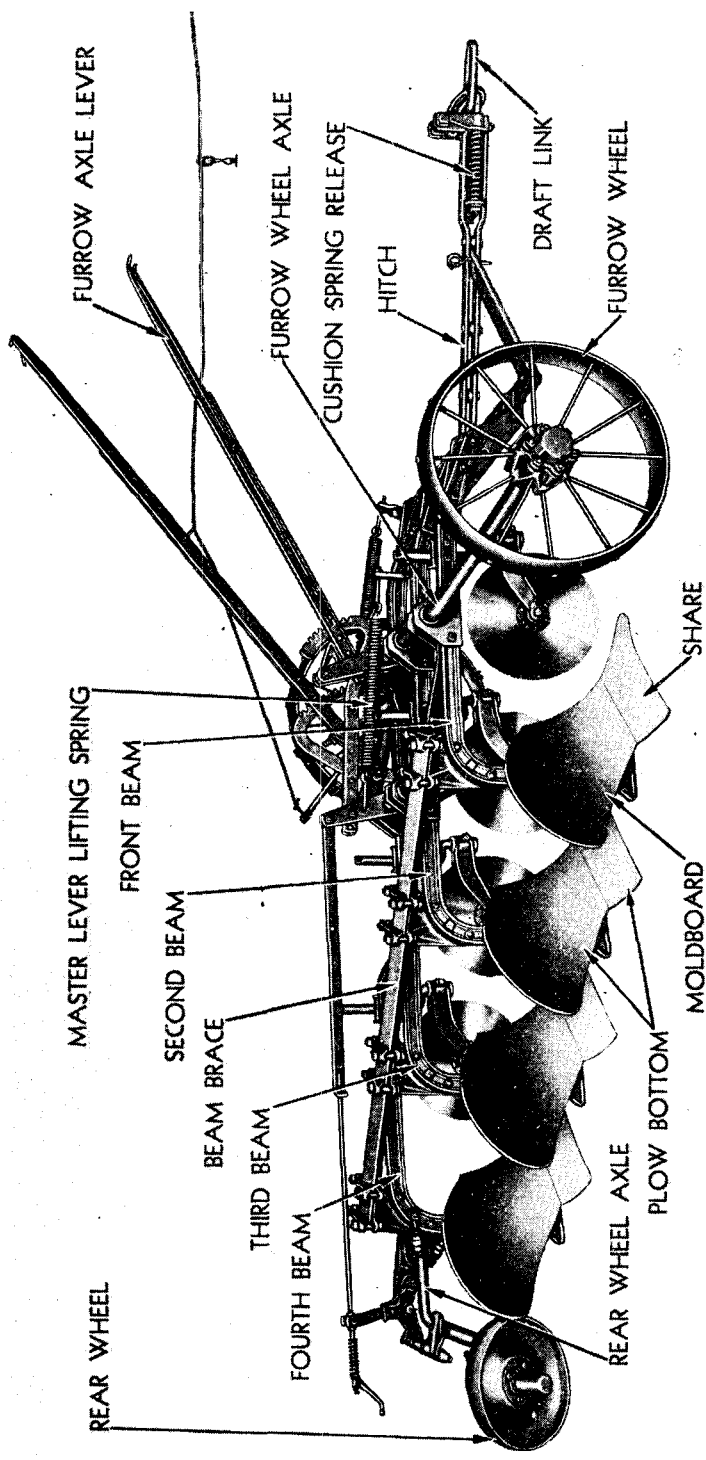

FIGURE 1—MOLDBOARD VIEW (RIGHT HAND) JOHN DEERE No. 7 TRACTOR PLOW

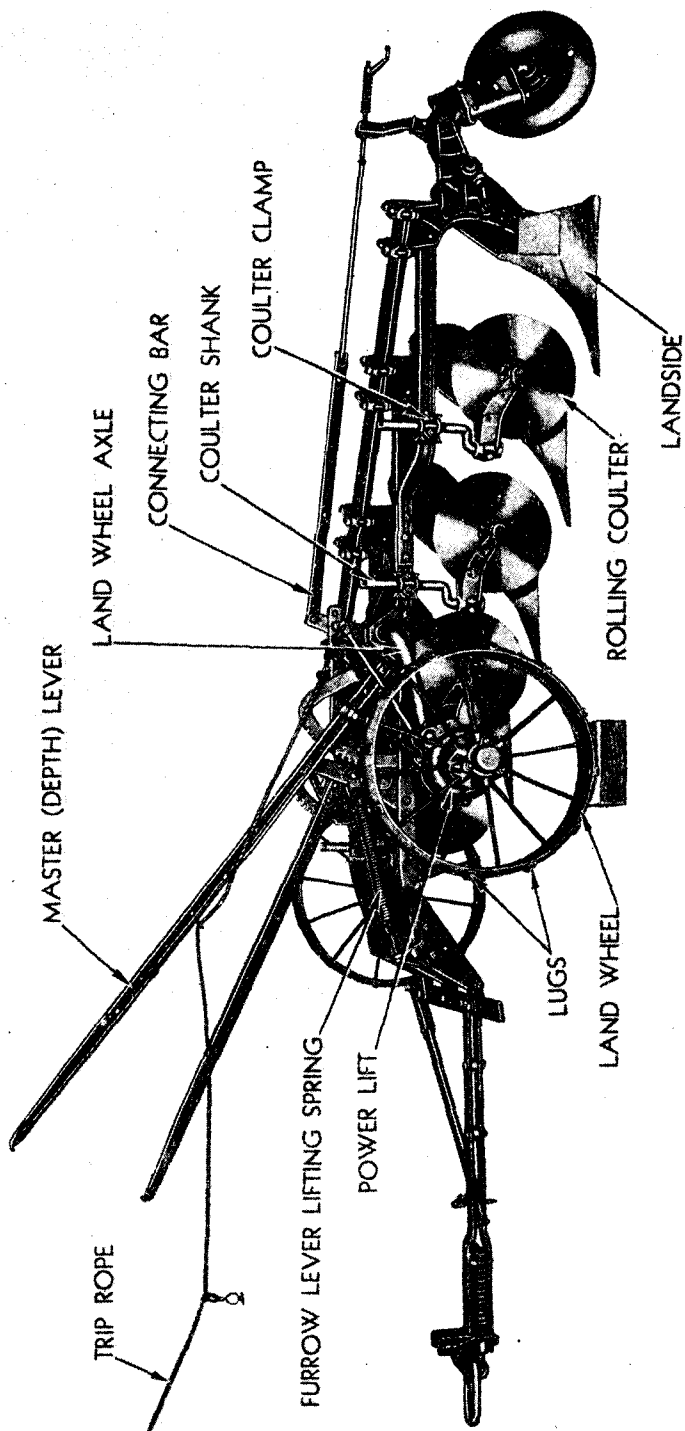

FIGURE 2—LANDSIDE VIEW (LEFT HAND) JOHN DEERE No. 7 TRACTOR PLOW

SECTION II

Description and Characteristics

1. **GENERAL DESCRIPTION.**—This Four-Bottom Tractor Plow is a heavy-duty moldboard plow designed for plowing in both medium or heavy conditions at a depth ranging from six to fourteen inches. It is equipped with an adjustable hitch permitting it to be pulled behind a variety of tractors or prime movers.

A. Identification.—This implement is illustrated in Figures 1 and 2 and shows left (landside) and right (moldboard) views. No serial number is assigned to this plow. It is referred to by model as “No. 7 Four-Bottom Tractor Plow”.

B. Mobility.—It is provided with three wheels which are in use both for transporting and plowing. When plowing, the right hand front wheel runs in the old furrow, the left hand wheel on the land, and the rear wheel in the new furrow.

C. Beams.—Beams are of Special No. 20 Beaded stock, heat treated, and are joined together with individual braces between the first, second and third beams. The entire frame unit is joined together with a heavy square brace bar mounted above the beams. This gives added strength and provides great clearance for trash.

D. Axles.—Three axles are mounted on the beams, one each for the Furrow Wheel, (right side) Land Wheel (left side) and Rear Wheel. Axles are attached to beams by means of bearings, collars and cotters.

E. Power Lift.—The power lift is mounted on the land axle (left side) and is of the enclosed type, housing all clutch parts in an oil tight case. When the clutch is tripped by means of a trip rope, the plow is lowered into the ground or lifted out. The clutch parts of the power lift are inactive except when lowering or lifting the plow.

F. Levers.—By means of two levers (one for the furrow axle and one for the land axle) the plow is leveled and set for the desired depth.

G. Lifting Springs.—Lifting springs prevent the plow from dropping too fast when the clutch is tripped, and assist the power lift in raising the plow out of the ground.

H. Plow Bottoms.—Plow bottoms are of the “deep tillage” type and will do good work at great depth. They cut a furrow 14" wide and all four bottoms will cut a total width of 56". The three main component parts of a bottom are the moldboard, share and landside.

I. Rolling Coulters.—Rolling coulters pivot on the shanks which are attached to the plow by means of clamps. One coulters is provided for each bottom, and cuts the land immediately in front to assist in turning over a clean furrow.

J. Hitch.—The hitch provides a wide range of adjustments both vertical and horizontal, adapting it to a variety of prime movers. Between the draft link which attaches the plow to the prime mover and the hitch,

two large coil springs are provided which serve not only as a cushion for the load, but also as a safety feature for the plow. When a solid rock or other obstruction is encountered by the plow, the coil spring compresses, releasing the draft link, and the plow becomes disconnected from prime mover. (See operator's instructions for adjusting.)

K. Connecting Bar.—The land axle and the rear wheel are connected to synchronize the lifting of the front and rear of the plow.

L. Specifications.—

Depth Range: Approximately 6" to 14".

Width of Cut: Four-Bottoms 14". Total Cut 56".

Bottoms: DT-356 Deep Tillage Bottoms. Bottoms have replaceable chilled shin on moldboard and replaceable chilled heel on landside.

Beam: Beaded steel beams, No. 20 stock, heat treated. 23" clearance under beams. 20" fore-and-aft spacing.

Wheels: Furrow Wheel, 32" Diameter, 6" Wide.
Land Wheel, 32" Diameter, 6" Wide.
Rear Wheel, 19" Diameter, 3" Wide.
All wheels revolve on steel sleeves on axle.

Hitch: Double cushion spring release hitch. Adjustable tripping load.

Levers: For depth control and leveling—adjustable for length.

Rolling Coulters: 18" Caster Rolling Coulters with 1-1/2" shanks.

M. Shipping Packages.—When packed for shipment, the No. 7 Plow is shipped in bundles which are partially assembled. This Four-Bottom Plow consists of the following bundles:

	<i>Approx. Weight</i>
1—Beams, Furrow Axle, 2 Lifting Springs, Beam Brace Bar, Connecting Bar and 4 Coulters Shanks.....	995 lbs.
1—Land Axle, Clutch and Wheel.....	296 lbs.
1—Levers and Ratchets.....	114 lbs.
1—JD1316 Furrow Wheel.....	120 lbs.
1—No. 21558 Rear Wheel.....	34 lbs.
1—Sack Clutch Rope and Grease Fittings.....	1 lb.
4—S10432 Rolling Coulters.....	120 lbs.
4—DT-356 No. 8 Plow Bottoms.....	400 lbs.
1—No. 65 Cushion Spring Release Hitch.....	155 lbs.

Total Weight 2235 lbs.

SECTION III

Setting-Up Instructions

1. GENERAL.—Cut bundling wires and arrange parts conveniently. Lubricate all bearings and moving parts as you proceed so they move freely.

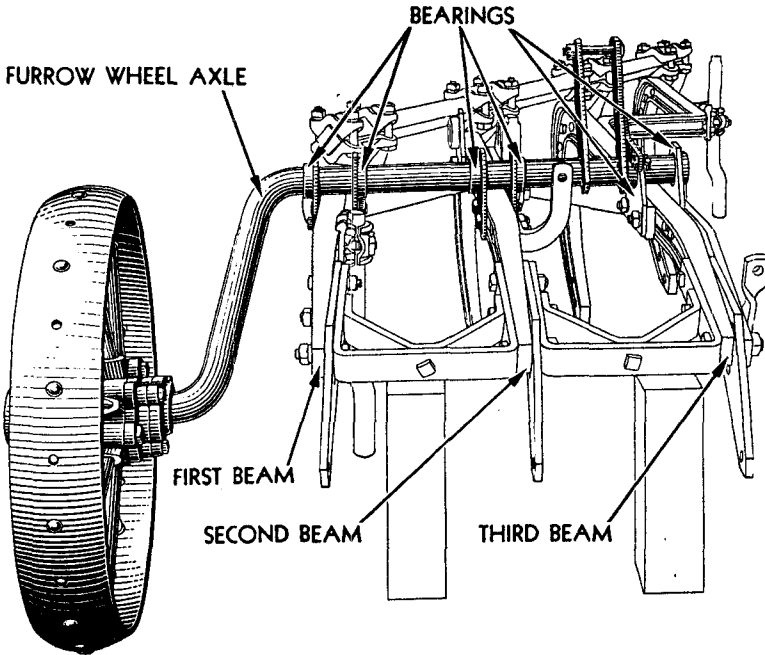

FIGURE 3—ASSEMBLING FURROW AXLE

2. BEAM AND FURROW AXLE.—(Figure 3.) Set the beam assembly (often referred to as frame) in a working position on a floor or other level surface. Place blocks under front end so it will not tip over. Place furrow wheel axle in position, inserting the end of axle through the bearings which are already attached to third beam. Then bolt the bearings assembled on the axle to the first and second beams.

3. FURROW WHEEL.—(Figures 3 and 4.) Remove the hub cap and all bearing parts. Place dust cap, grease seal felt and wheel box on axle. Be sure the dust and grease seal felt is carefully placed in dust cap. Place two wearing washers on axle. Place bearing sleeve on axle and pin rigidly to axle. Put on wheel. Place two bearing washers, then hub cap on sleeve and bolt tight. Put long bolts through dust cap and wheel box, and short bolts through wheel box only. While assembling, grease

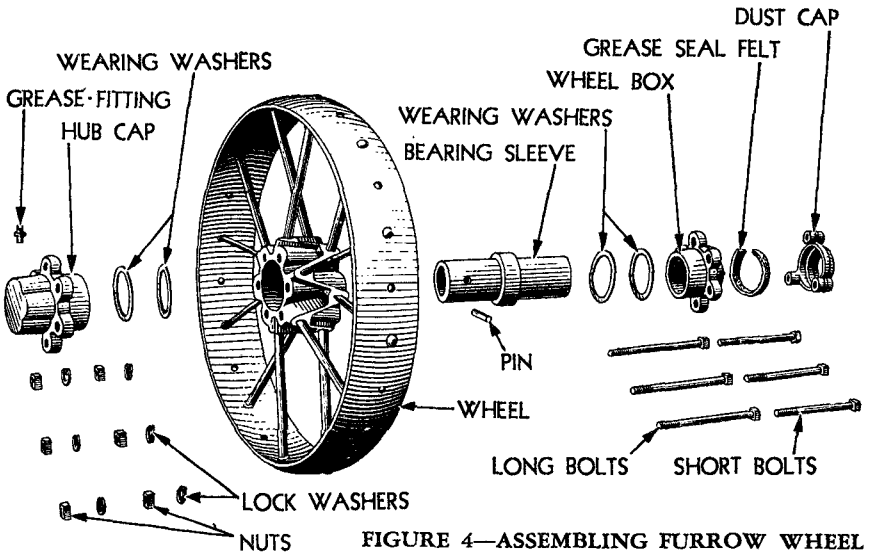

FIGURE 4—ASSEMBLING FURROW WHEEL

thoroughly, using approximately ten ounces of No. 3 grease or equivalent.

4. LAND AXLE, WHEEL AND POWER LIFT.—(Figure 5.) Attach land axle and wheel assembly by first inserting the end of axle through the axle bearings that are attached to the second beam. **IMPORTANT:** Remove hub cap in order to observe grease being forced out through bearing on outer end of axle while being applied through grease fitting. Use No. 3 Cup Grease or equivalent. Bolt hub cap on the wheel. Bolt lugs to wheels.

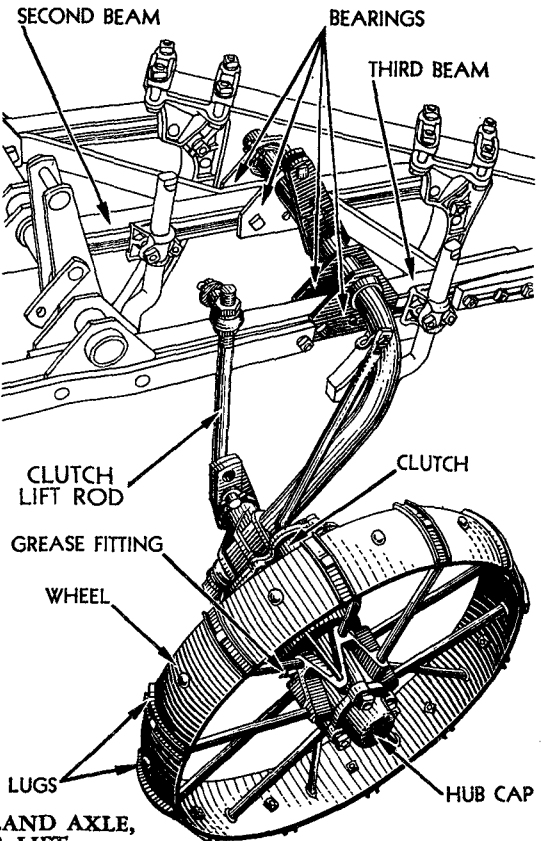

FIGURE 5—ASSEMBLING LAND AXLE, WHEEL AND POWER LIFT

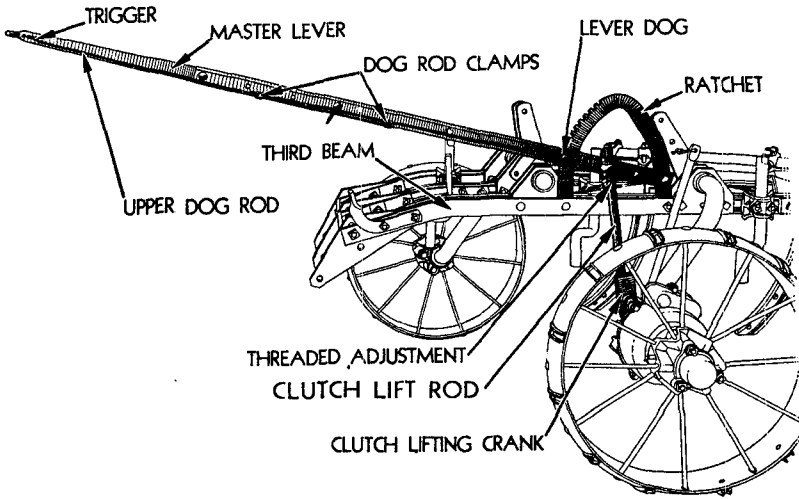

FIGURE 6—ATTACHING MASTER LEVER

5. **MASTER LEVER.**—Bolt master lever and ratchet to position on third beam. (Figure 6.) Attach clutch lifting rod to master lever and clutch lifting crank. Note: As shipped, lock washers are placed between upper and lower parts of levers. The bolts which hold the parts together should be removed, levers placed in desired length, lock washers placed *underneath* the nuts on bolts. When bolting dog rods together, be sure dog fits into notch on ratchet. Pull upper dog rod and lever trigger down and tighten bolts on dog rod clamps.

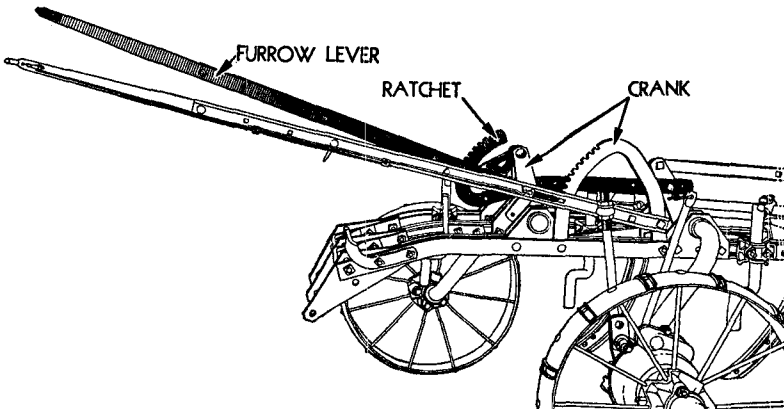

FIGURE 7—ATTACHING FURROW LEVER

6. **FURROW LEVER.**—Attach lever and ratchet to cranks welded on furrow and land axles. (Figure 7.) Follow same procedure in bolting levers and dog rods together as master lever. (See operating instructions for adjustments.)

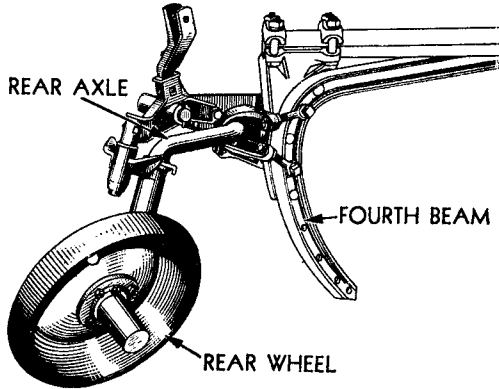

FIGURE 8—ATTACHING REAR AXLE AND WHEEL

7. REAR AXLE AND WHEEL.—Attach rear axle onto fourth beam. (Figure 8.) Place inside box with rear wheel on axle. (Figure 9.) Place wearing washer and bearing sleeve on axle and pin rigidly to axle. Grease wheel sleeve thoroughly with No. 3 Cup Grease or its equivalent. Place wearing washer and outside wheel box on axle and bolt tight.

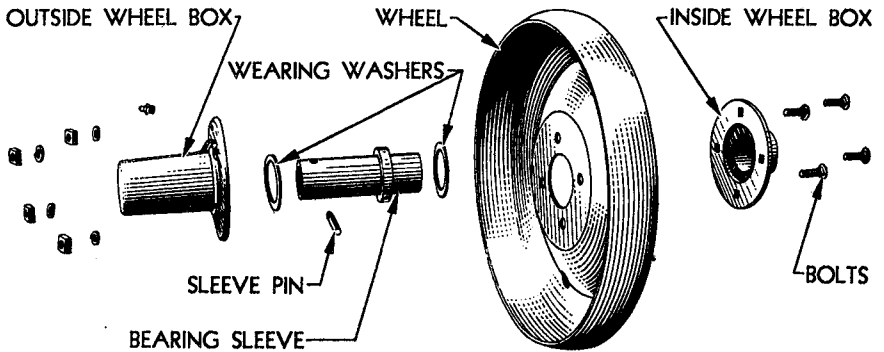

FIGURE 9—ASSEMBLING REAR WHEEL

8. CONNECTING BAR.—Attach connecting bar to land axle crank and to the rear wheel arm. (Figure 10.) See operating instructions for adjusting.

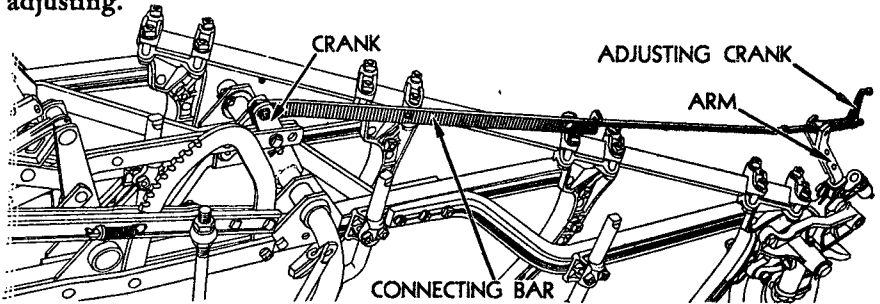

FIGURE 10—CONNECTING BAR

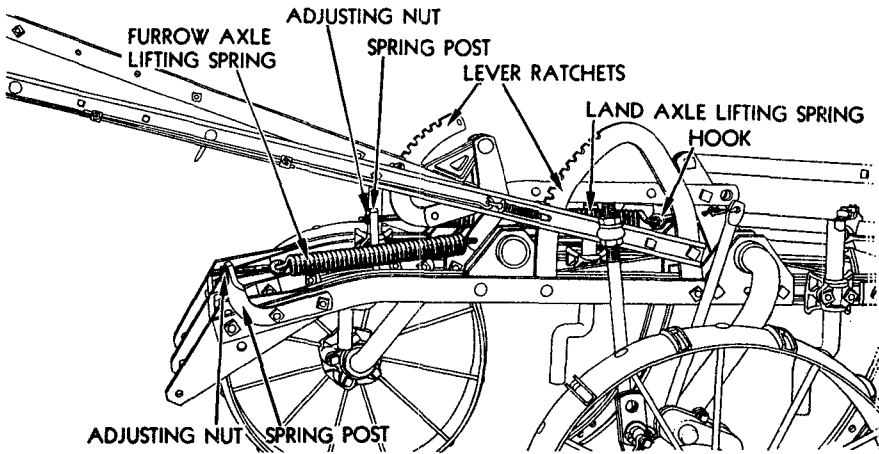

FIGURE 11—LIFTING SPRINGS

9. **LIFTING SPRINGS.**—Pull both levers down into lowest setting on lever ratchets. Place plow in lifted position by moving trip lever forward on lifting clutch and pulling plow forward until the plow is lifted and clutch locks into position. One revolution of the land wheel will lift the plow. Hook smaller lifting spring to crank on furrow axle. (Figure 11.) Put spring adjusting bolt through post on frame and adjust to medium tension. Attach larger lifting spring to eye in hook on land axle crank. Put spring adjusting bolt through post on second beam and adjust to medium tension. (See operating instructions for adjusting.)

10. **BOTTOMS.**—With the plow still in lifted position, attach all plow bottoms to beams. (Figure 12.) These bottoms are common and will fit on any of the beams. Start with the first beam, then the second, and so on. Be sure all bolts are tightened securely. Use a large long handled wrench.

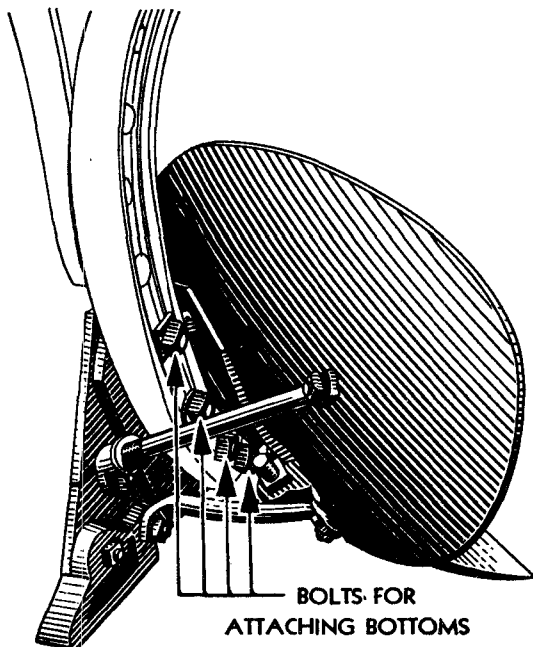
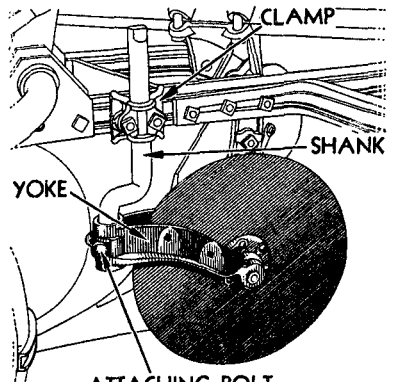

FIGURE 12—ATTACHING BOTTOMS

11. COULTERS.—Attach rolling couler yoke to shank on beams. (Figure 13.) (See operating instructions for adjusting.)



ATTACHING BOLT
FIGURE 13—ATTACHING ROLLING COULTER

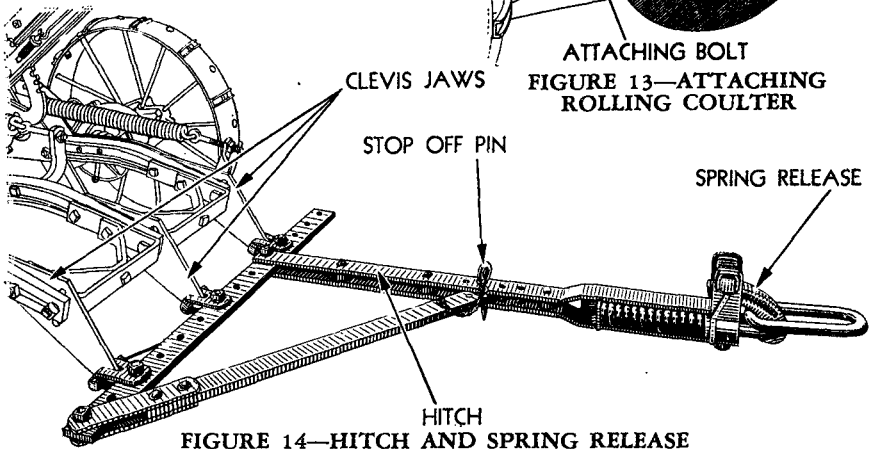

FIGURE 14—HITCH AND SPRING RELEASE

12. HITCH AND SPRING RELEASE.—Attach hitch to clevis jaws. (Figure 14.)

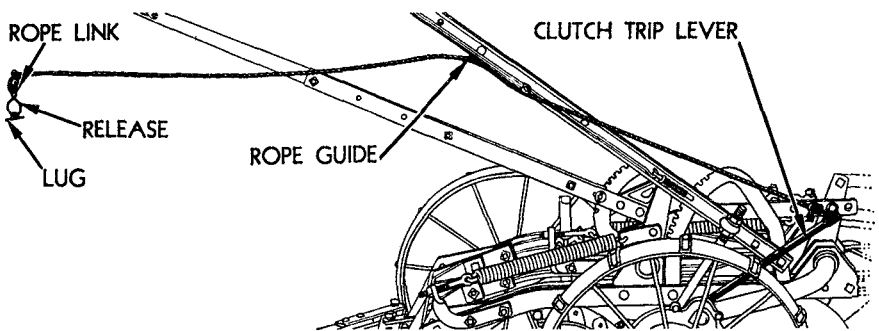

FIGURE 15—CLUTCH ROPE

13. ROPE.—(Figure 15.) Attach end of rope to clutch trip lever. Thread rope through rope guide. After plow is hitched to prime mover, attach rope link on end of rope toward prime mover so that link will just reach the operator's seat. Attach spring rope release to seat by inserting lug through one of the holes in seat. Attach link to spring release.

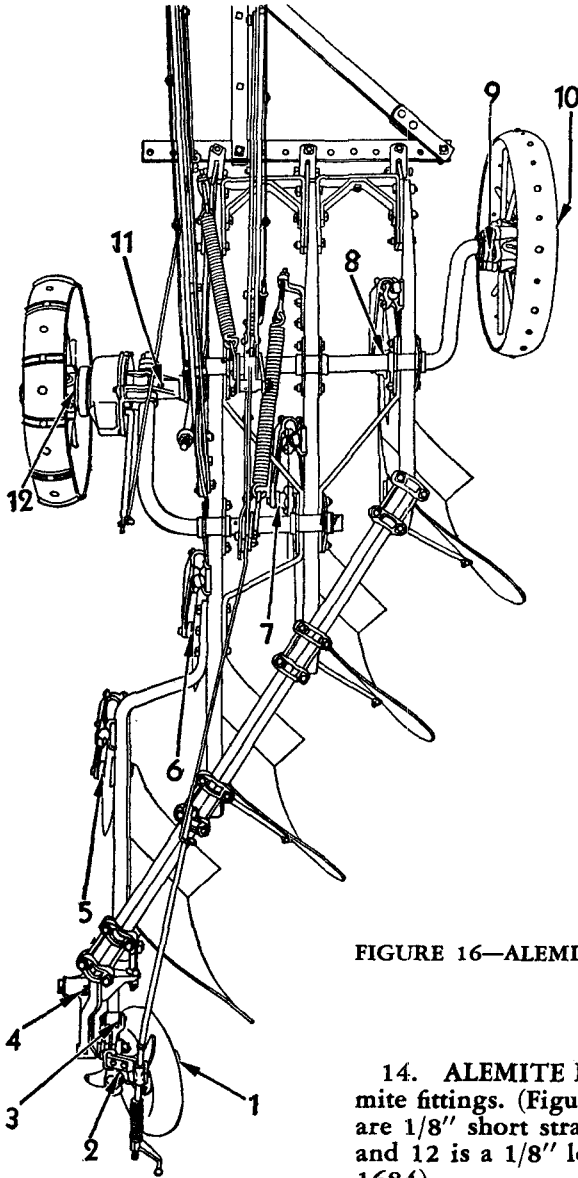

FIGURE 16—ALEMITE FITTINGS

14. ALEMITE FITTINGS.—Insert Alemite fittings. (Figure 16.) 1 to 11 inclusive are 1/8" short straight fittings (No. 1610) and 12 is a 1/8" long straight fitting (No. 1684).

15. CHECK AND LUBRICATE.—Check plow completely. Tighten all units and spread all cotter keys. Lubricate thoroughly as shown in lubrication chart page 21.

16. REMOVE VARNISH.—The moldboards, shares, landsides and rolling coulter blades have been highly polished and varnished at the factory to prevent rust. Before starting, remove varnish with varnish remover.

SECTION IV

Operating Instructions, Adjustment and Control

1. **CONTROLS.**—The controls are employed to properly hitch the plow behind prime mover, regulate depth of plowing and uniform cutting of furrow width; even penetration of plow bottoms (leveling) and lowering plow into ground and raising plow out of ground.

The operator must become thoroughly familiar with the location, use and adjustment of all control devices before attempting to operate the plow.

A. Hitch.—Attach draft link to hitch of prime mover. Drive ahead until plow is lined up with prime mover, and adjust hitch so drawbar is parallel to line of travel.

a. Opening up the land. The first time around the field, the land is "opened up". Then both furrow and land wheels run on top of the ground, and only the rear wheel runs in the furrow. After the first round, the front furrow wheel and the rear wheel run in the furrows, and the land wheel runs on top of the ground. After the land has been opened up, place the plow in working position with front furrow wheel in the furrow. Detach prime mover and place it in normal working position, adjust hitch so the front bottom cuts a furrow slice 14 inches wide and attach prime mover to plow.

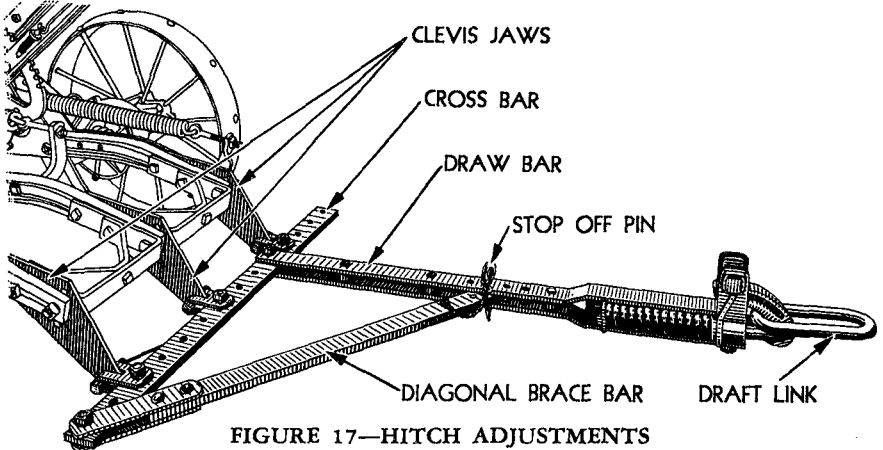

FIGURE 17—HITCH ADJUSTMENTS

b. Horizontal hitch adjustment. This adjustment is provided so the plow can be hitched to pull straight and in proper working position with each furrow cutting a furrow slice 14 inches wide behind prime mover. Whether opening the land or doing regular plowing, the drawbar should always be approximately parallel to line of travel. To adjust drawbar, move right or left on cross bar, and then adjust diagonal brace bar to proper position, and lock with stop off pin. (Figure 17.)

c. Vertical hitch adjustment. This adjustment provides a means of raising or lowering the hitch on the clevis jaws of the plow so that

a straight line of draft can be maintained between the drawbar of the prime mover and the center of draft in the plow. (Figure 18.)

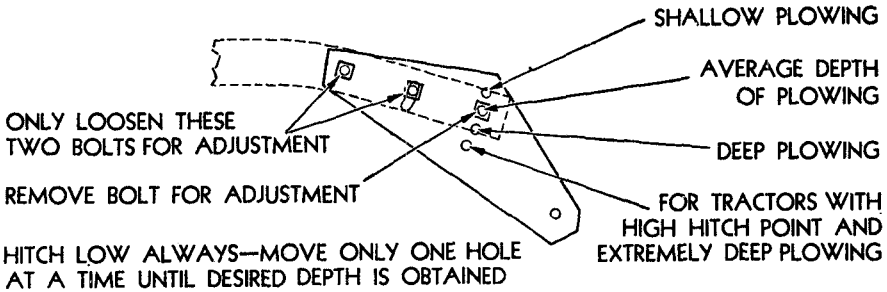

FIGURE 18—CLEVIS JAW ADJUSTMENT

If the vertical adjustment of the hitch is correct, the weight of the plow will be properly distributed on all three wheels, whether plowing shallow or deep. If the hitch is too high, little or no weight will be carried on the rear wheel, and the plow has the tendency to ride on the share points. If the hitch is too low, too little weight will be carried by the furrow and land wheel and the plow has the tendency to “come out” of the ground.

The top hole in the clevis jaws is generally used for shallow plowing (6" to 8"). For average depth of plowing from 8" to 10" deep, use second hole from top. For deeper plowing use third hole. For extreme deep plowing and tractors with very high hitch use fourth hole. (Figure 18.)

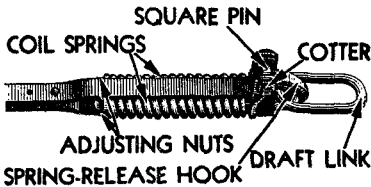

FIGURE 19—SPRING RELEASE
HITCH CLOSED

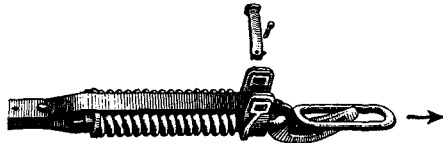

FIGURE 20—SPRING RELEASE
HITCH RELEASED

d. Cushion spring release hitch. The large coil springs (Figure 19) serve not only as a cushion for the load, but also as a safety feature. When a large rock or other obstruction is encountered by the plow, the coil springs in the hitch compress, releasing the draft link (Figure 20) and the plow becomes disconnected from the tractor. To re-attach plow to tractor, remove cotter from square pin. Remove square pin, put spring release hook in proper position, replace square pin and cotter. After removing obstruction causing disconnection of plow from prime mover, back up prime mover and attach draft link to drawbar.

Tension of coil springs can be adjusted to suit varying plowing conditions by adjusting nuts. For hard ground, tension should be tightened.

B. Trip Rope.—Adjust clutch trip rope to proper length between plow and prime mover. To drop plow into ground, pull the clutch rope, with prime mover moving forward. To raise plow, pull same rope. In raising or lowering the plow, do not pull rope after clutch begins to operate or the clutch will repeat its operation.

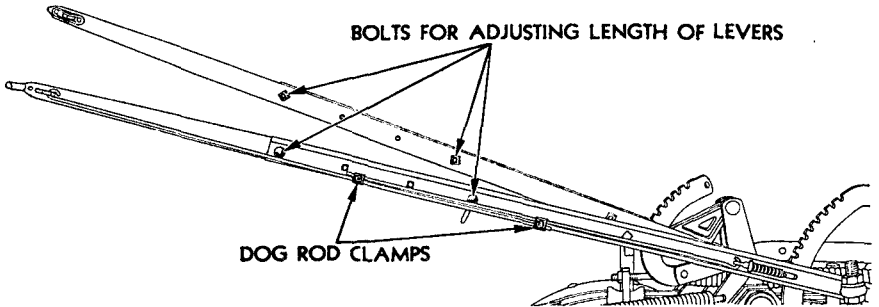

FIGURE 21—ADJUSTING LEVERS

C. Levers.—After plow is hitched to prime mover, adjust each lever so they are within convenient reach of the operator. (Figure 21.) **CAUTION:** Do not have levers too long. They may interfere with the operator, or be damaged by striking seat or fenders of prime mover when turning or going through deep furrows or ditches.

The master lever is used to control or change the depth of plowing when starting to plow or when plow is in actual operation. If the field being plowed has a variety of soil conditions, such as wet or dry, hard or sandy spots, or prime mover does not have sufficient power to move plow through these places at predetermined depth, lever can be pulled down to decrease depth (Figure 22), or moved up to increase depth (Figure 23).

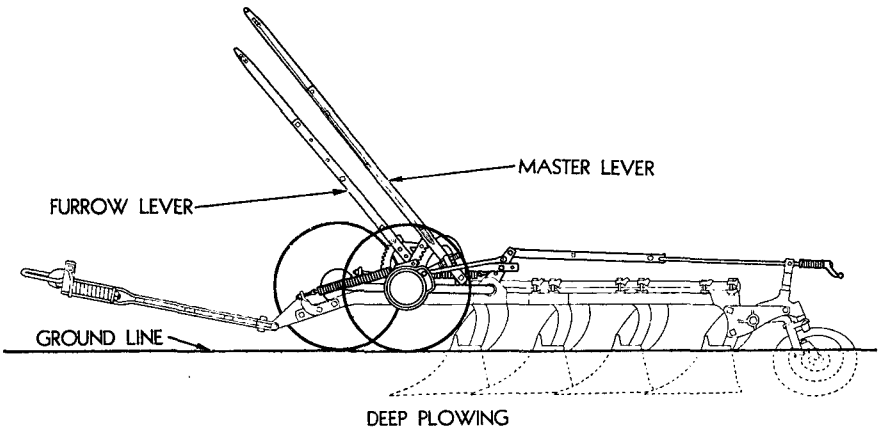
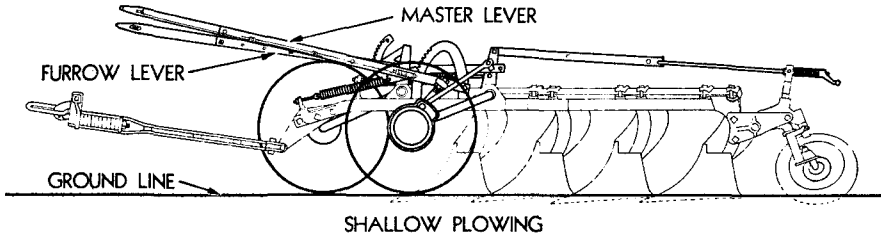

FIGURE 22—LEVER ADJUSTMENT FOR DEEP PLOWING

By means of the furrow lever, the furrow wheel is raised by pulling lever down and lowered by moving lever up. The plow is leveled by raising or lowering the furrow wheel. Maintaining proper level permits each bottom to turn over the same thickness of furrow slice as all the others.



SHALLOW PLOWING
FIGURE 23—LEVER ADJUSTMENT FOR SHALLOW PLOWING

D. Additional Depth Adjustments.—When the plowing depth range provided in the levers is insufficient, a new depth range can be obtained on the lever ratchets by using the adjustment on the clutch lift rod, and the front furrow lever ratchet bar.

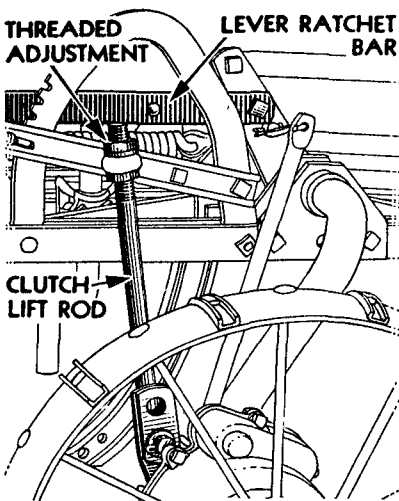

FIGURE 24—ADJUSTMENT FOR MEDIUM OR DEEP PLOWING

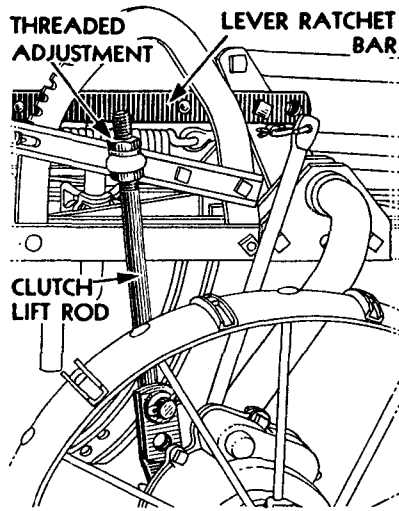

FIGURE 25—ADJUSTMENT FOR SHALLOW PLOWING

For medium or deep plowing, use inner hole in the clutch lifting crank and the rear hole on the ratchet bar. (Figure 24.)

For shallow plowing use outer hole in the clutch lifting crank, and front hole in the ratchet bar (Figure 25).

The threaded adjustment at the end of the clutch lifting crank can be turned down for deeper plowing and up for shallower plowing. Lock into position by tightening both nuts—tight.

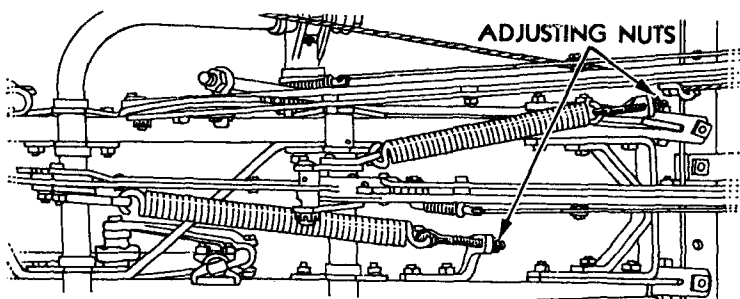

FIGURE 26—ADJUSTING LIFTING SPRING

E. Lifting Springs.—The lifting springs should have proper tension. If the springs do not have enough tension, the land wheel may slide before lifting the plow, and the hand levers will be difficult to adjust. If the springs are too tight, the plow will not drop quickly when the clutch is tripped, resulting in slow penetration. To tighten, turn nuts on end, clockwise. Reverse movement to loosen (Figure 26).

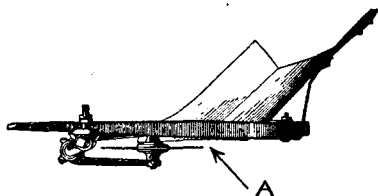

FIGURE 27—LATERAL ADJUSTMENT OF ROLLING COULTER

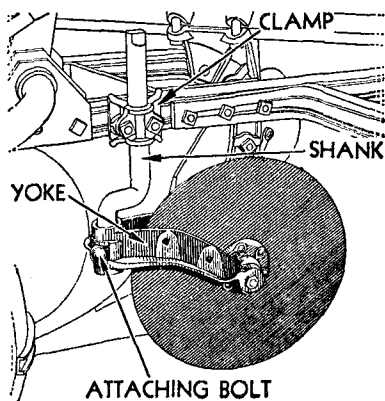

FIGURE 28—ROLLING COULTER

F. Rolling Coulters.—For all conditions the coultter must be set so that the blade will run from 1/2" to 5/8" to the left of the landside of the share (Figure 27). This adjustment is made by loosening the beam clamp bolts and turning shank in clamp (Figure 28).

In ordinary conditions, coultter should be set only deep enough to cut ground and trash (Figure 29). In hard ground they should not run so deep as they will prevent the plow from scouring properly. **CAUTION:** Do not set too deep as it will push trash instead of cutting through it. (Figure 30.)

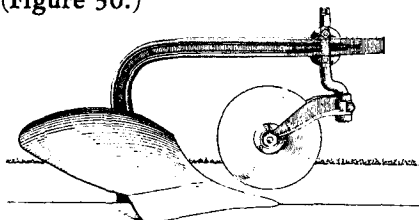

FIGURE 29—PROPER SETTING OF ROLLING COULTER

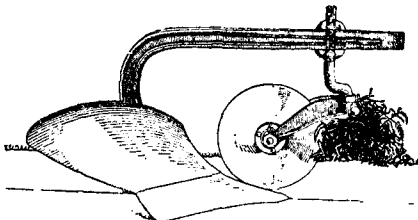

FIGURE 30—IMPROPER SETTING OF ROLLING COULTER

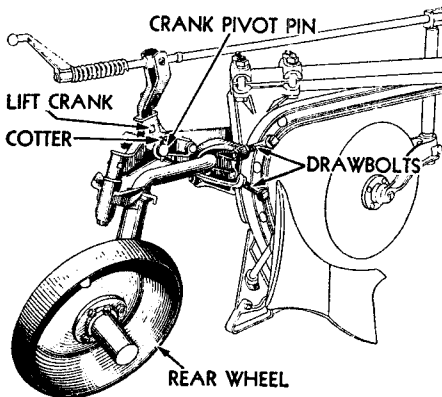

FIGURE 31—UP AND DOWN
ADJUSTMENT OF REAR WHEEL

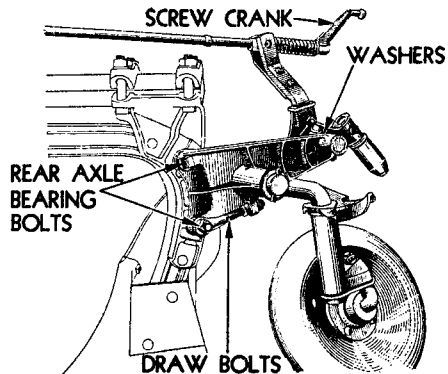

FIGURE 32—LATERAL ADJUST-
MENT OF REAR WHEEL

The couler yoke is held to the shank with a set collar which must be adjusted so the couler can swing an equal distance to the right or left of the line of travel. This will permit the couler to pivot on the shank when the plow is being turned.

G. Rear Wheel.—The bottom of the rear wheel should be in line with the bottom of the heel of the landside.

To adjust rear wheel up or down, loosen rear axle bearing bolts on left side and adjust the two draw bolts on right side. Tightening nut on top bolt raises wheel. Tightening nut on bottom bolt lowers wheel. After satisfactory adjustment has been made, lock into position by tightening both nuts on each adjusting bolt. Tighten axle bearing bolts. (Figures 31 and 32).

Lateral adjustment of the rear wheel is made by adjusting the large draw bolt on left side. First loosen rear axle bearing bolts. Tightening bolt moves wheel to left, loosening bolt moves wheel to right. The two draw bolts on right side must be adjusted proportionately. Lock all draw bolts into position by tightening all nuts.

To change the landing or line of travel in the rear wheel, add or deduct washers. Remove cotter from crank pivot pin, slide off lift crank, add or deduct washers as needed, replace lift crank and cotter.

The screw crank (Figure 32) should be adjusted so the rear wheel is locked in a fixed position when plowing, and locked out when the plow is lifted so the wheel may caster.

SECTION I

1. **PLOW BOTTOMS AND COULTERS.**—Protect the face of the moldboard, share, and landside from rust between plowing seasons or intermittent periods by greasing the polished surfaces with a coat of No. 3 Cup Grease or hard oil

2. **SHARPENING THE SHARES.**—Heat the point of the share to a low cherry red (not too hot) and hammer the top side until the point is sharp. Hammer at a cherry red only. Do not work the share at a high heat, as it destroys the quality of the steel. Draw the entire cutting edge from the underside until sharp. Heat at one time only as much as can be hammered. The body of the share should not be heated while sharpening, but should remain cool so as not to disturb the fitted edges.

Should the share get out of shape, or the fitted edges become warped, during the sharpening process, put the blade in proper shape before hardening. This can be done best at a black heat. If share is too badly worn replace with new one.

3. **HARDENING SOFT CENTER STEEL SHARES.**—Prepare the fire to heat the entire share uniformly to a cherry red. Care should be used in getting the heat uniform. Take the share from the fire and dip into a tub of clean, cold water. Put the share into the water with the cutting edge down. Keep the blade perpendicular during the process.

4. **SHARPENING THE COULTER BLADE.**—Remove the blade from the coultter yoke and grind the blade on an emery wheel until sharp. After repeated sharpenings, blade will be too small to do effective work. Replace with new one.

5. **COULTER BEARINGS.**—The coultter bearings are conical in shape and are adjustable for wear. To take up the bearing, loosen the lock nut on the bearing bolt. The bearing bolt is threaded into the coultter yoke. Tighten the bolt until the coultter bearings fit snugly. If bearings are worn to the extent where they cannot be properly adjusted, replace with new one.

6. **WHEEL BEARINGS.**—The wheel bearings are of hard chilled grey iron, and with proper lubrication there should be practically no wear on these bearings. In each wheel box there is one or more washers on each side of the collar. These washers take the end thrust, and at least once each season the wheel bearings should be disassembled and the washers checked and new washers put in if necessary.

7. ADJUSTING THE CLUTCH.

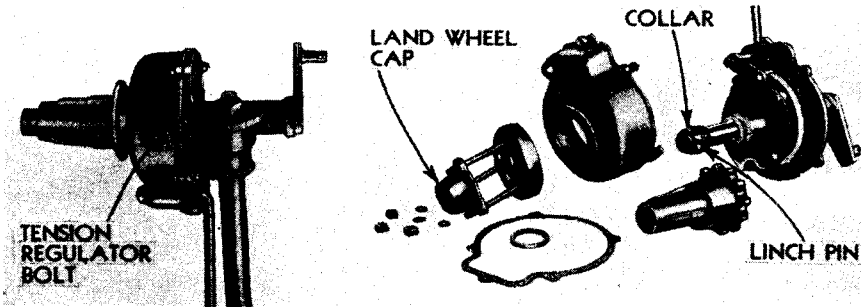

FIGURE 33

The lifting clutch mechanism is completely enclosed and sealed to keep out dirt. It should be greased with an Alemite gun at the fittings provided in the land wheel box and land axle journal.

The adjustable collar (Figure 33) at the outer end of the stub axle provides a simple take-up adjustment, if end-play becomes apparent after a period of time. This adjustment can be made by simply removing the land wheel cap turning the collar, and locking with linch pin; it is not necessary to take the clutch apart.

IMPORTANT: The tension regulator bolt at the front of the clutch housing regulates the tension on the spring controlling the throw-out lever. Tension is properly adjusted when clutch is built, but should greater tension become necessary the bolt should be tightened by turning the bolthead one or two turns clockwise. *Never loosen this bolt*, or the spring inside the clutch housing may become disconnected.

Ordinarily the simple adjustments above will remedy most clutch difficulties. However, if the trouble cannot be corrected by making the above adjustments, check the following:

Inside clutch spring (No. 1548A) may be broken.

Clutch roller (No. 25936A) may be worn.

Parts inside clutch may be broken.

Before clutch is reassembled, all parts should be thoroughly washed with gasoline. When reassembling, put one pound of light grease inside clutch. Use Maximus No. 1 or its equivalent which will adhere to the moving parts but not become fluid at any temperature.

KEEP NUTS TIGHT:

Tighten all nuts. The nuts on the plow bottoms should be inspected periodically. Replace bent bolts or bolts with stripped threads. Loose parts come off or bend easily.

8. LUBRICATION INSTRUCTIONS

Alemite Hydraulic lubrication fittings are provided at all points numbered in the lubricating chart below.

The same grease gun which is used to lubricate the prime mover should be used to grease the plow. No. 3 Cup Grease or an equivalent grade of lubricant which has sufficient body to prevent dirt from working into the bearings should be used.

All parts provided with grease fittings should be lubricated twice daily. The working parts on the levers, axle bearings on the beams, and other moving parts on the plow should be oiled twice daily with an oil can containing a good grade of lubricating oil.

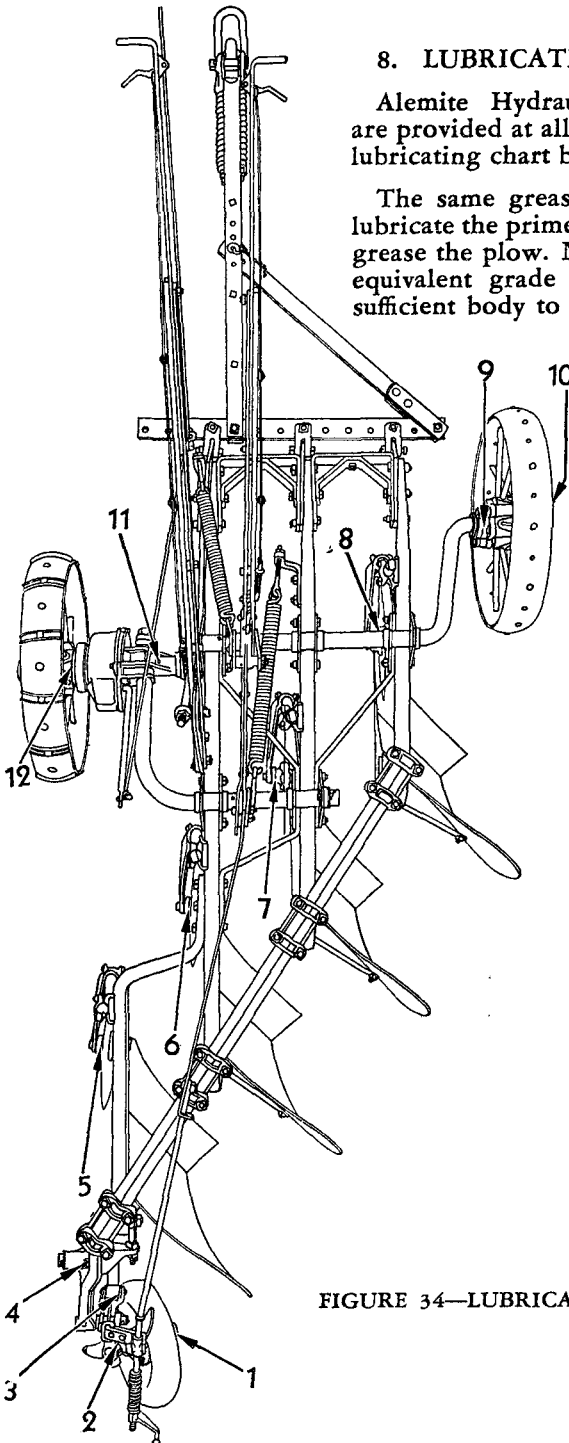

FIGURE 34—LUBRICATION

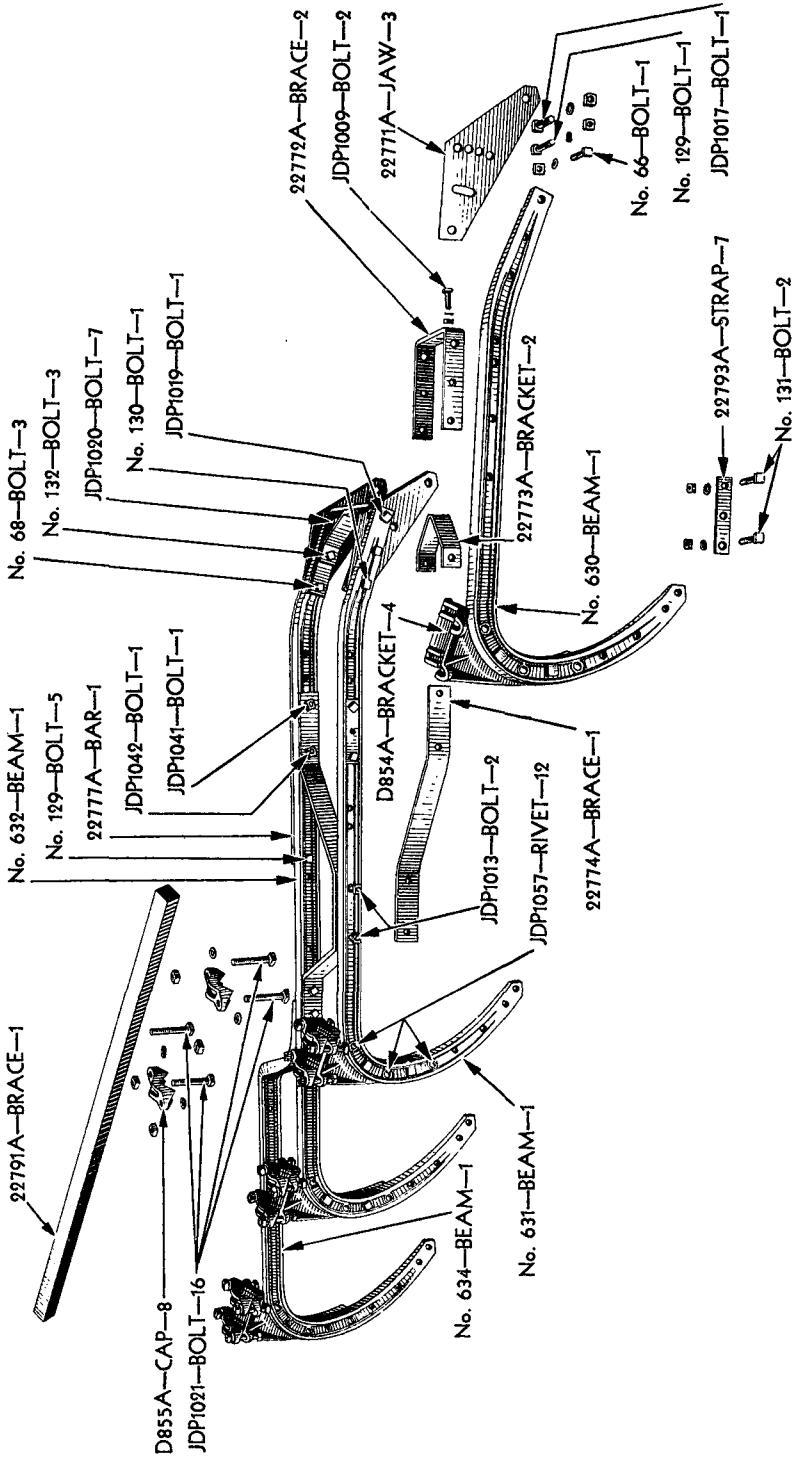

FIGURE 35—BEAMS AND BRACES

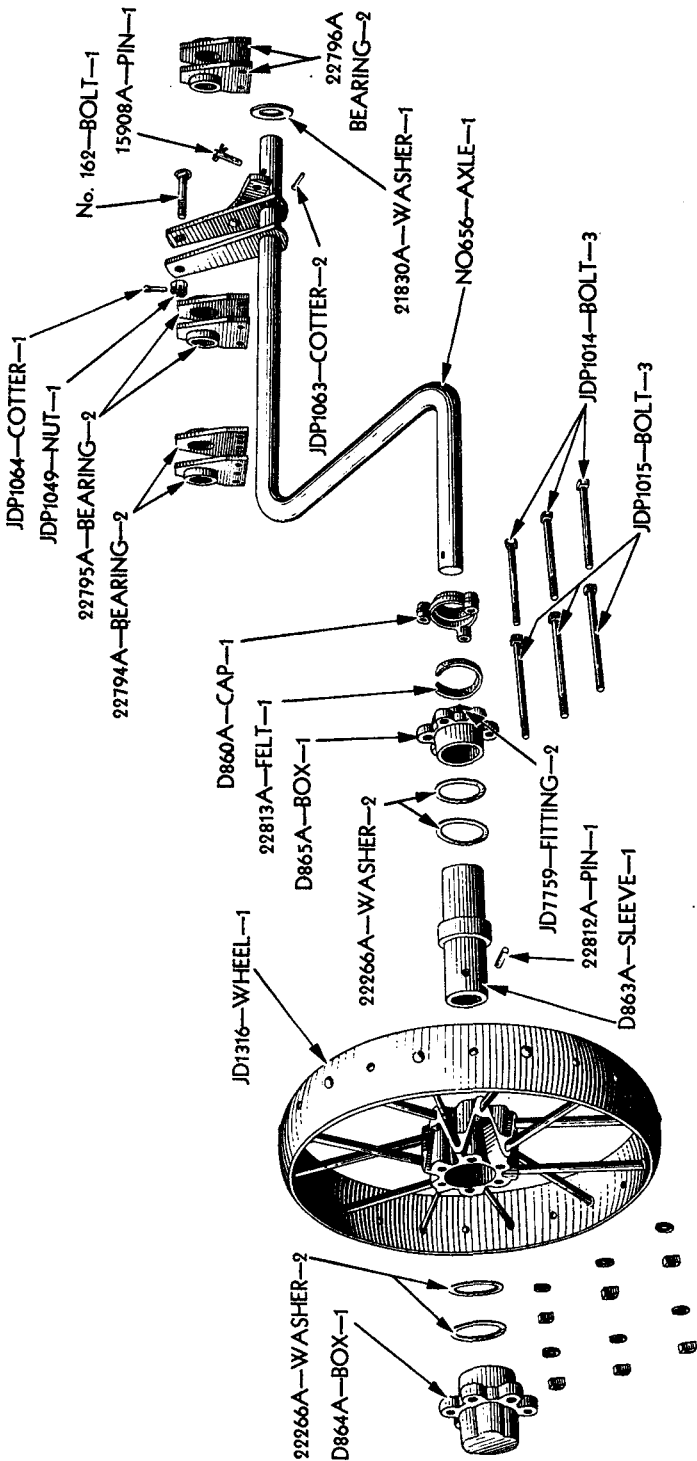

FIGURE 36—FURROW WHEEL AND AXLE

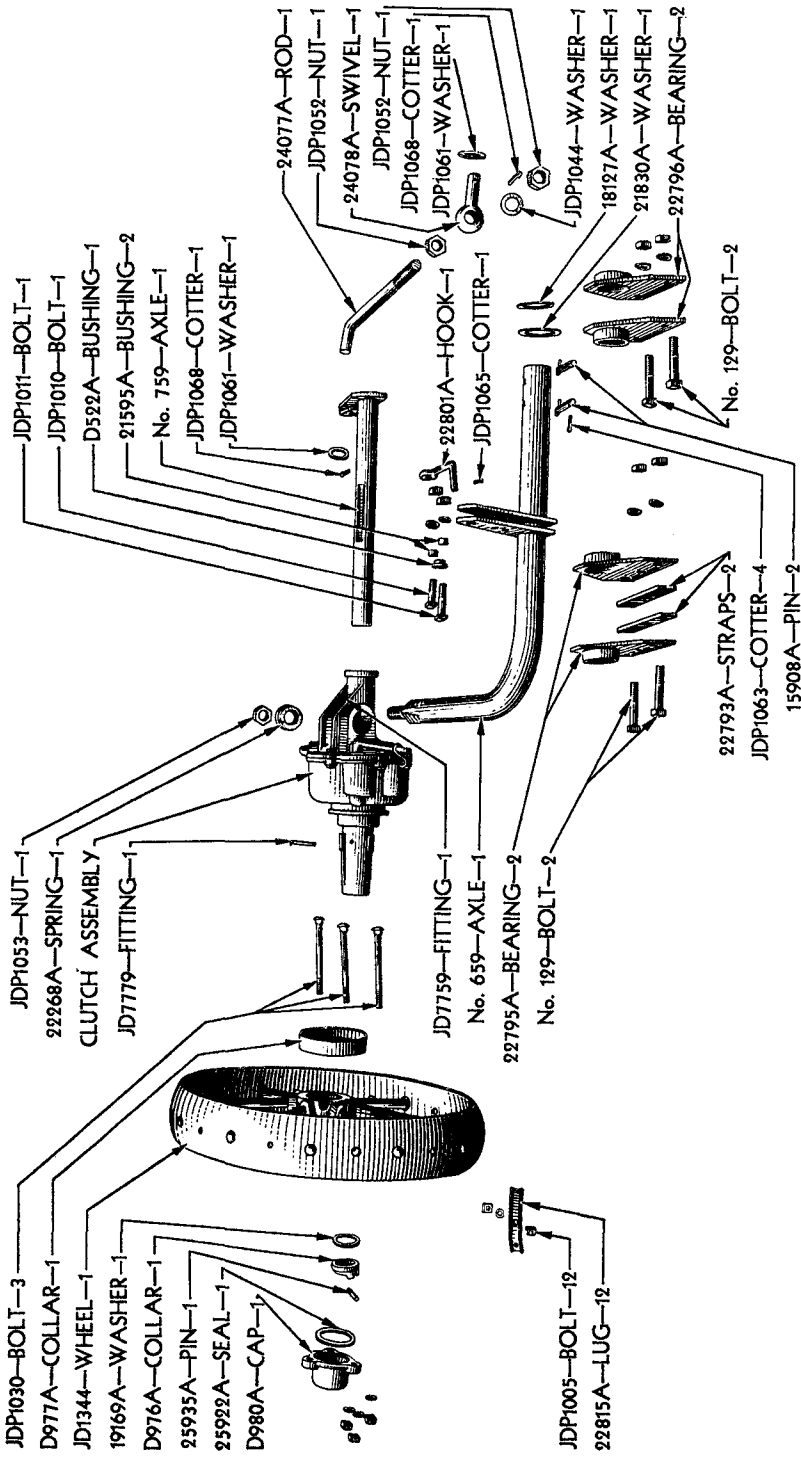

FIGURE 37—LAND WHEEL, AXLE AND POWER LIFT

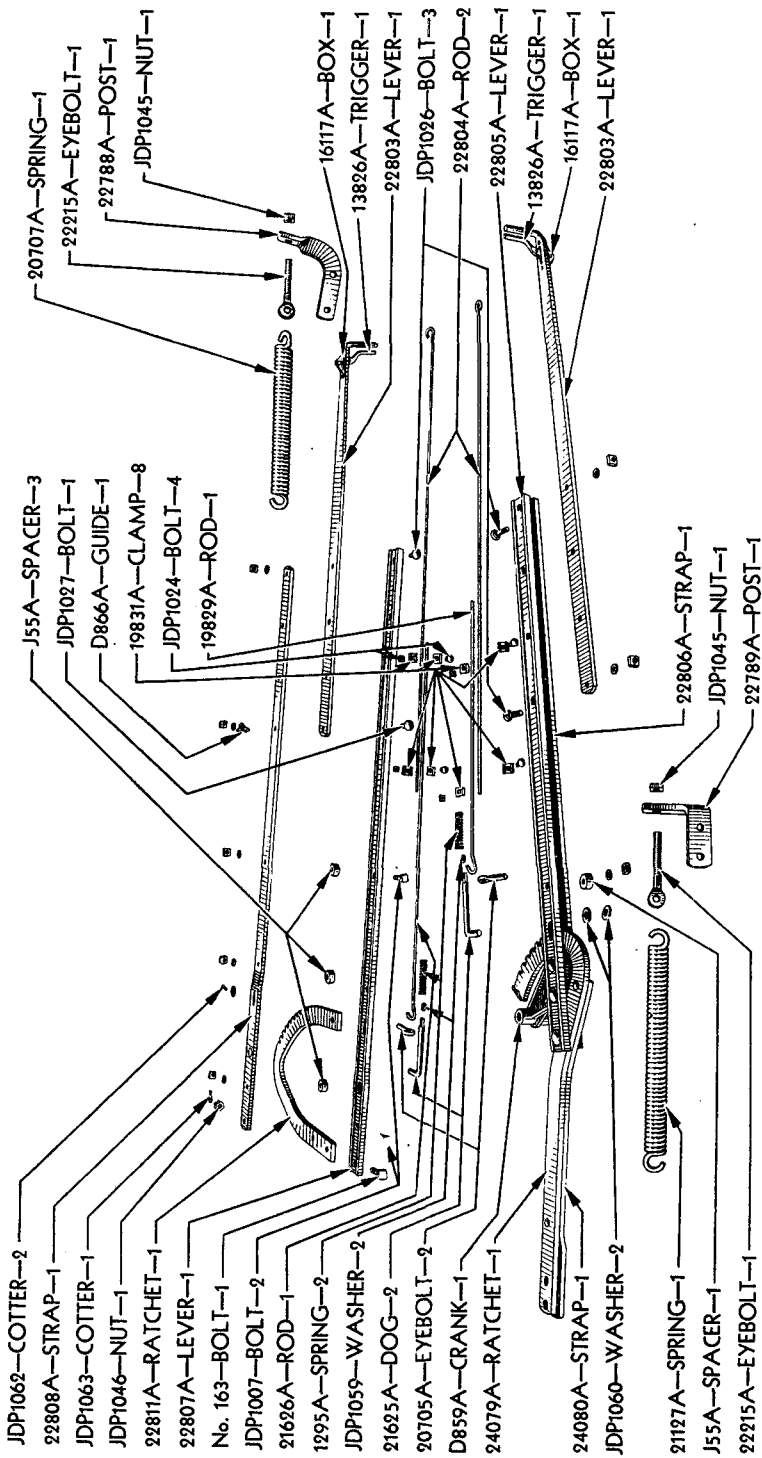

FIGURE 38—LEVERS AND LIFTING SPRINGS

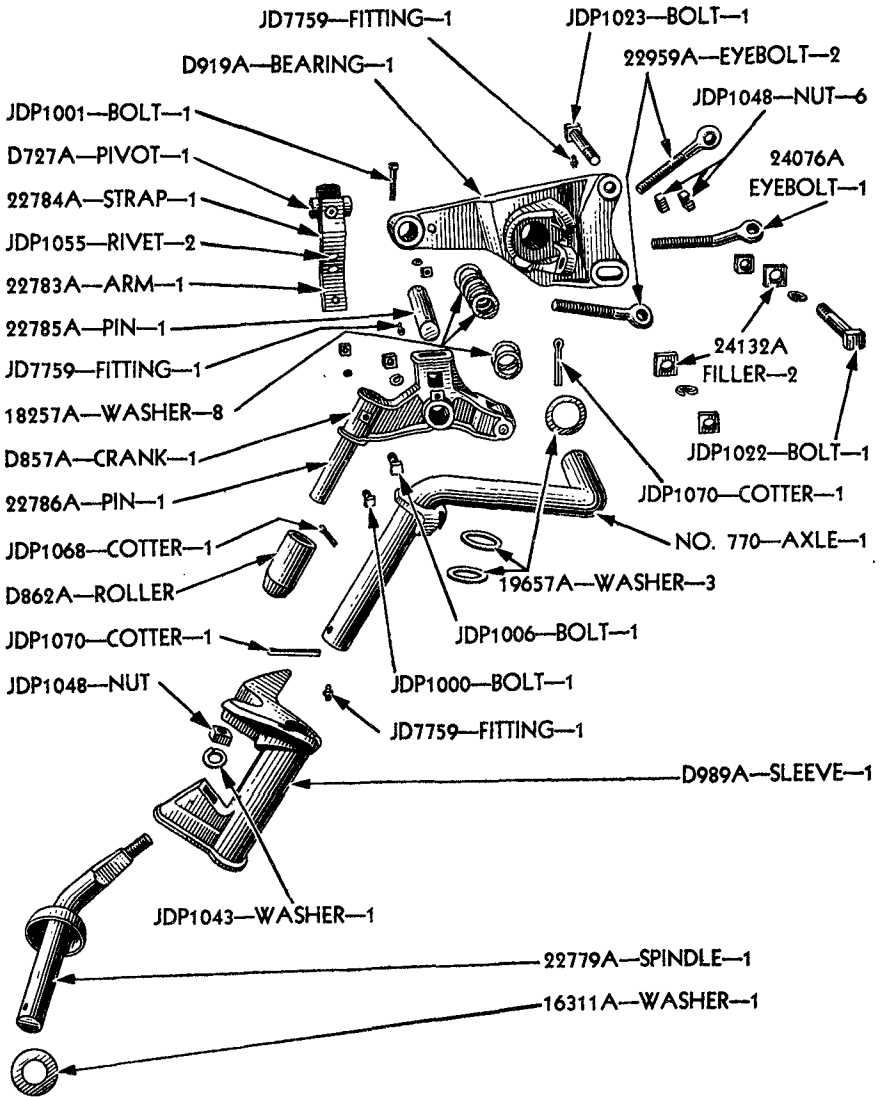

FIGURE 39—REAR AXLE

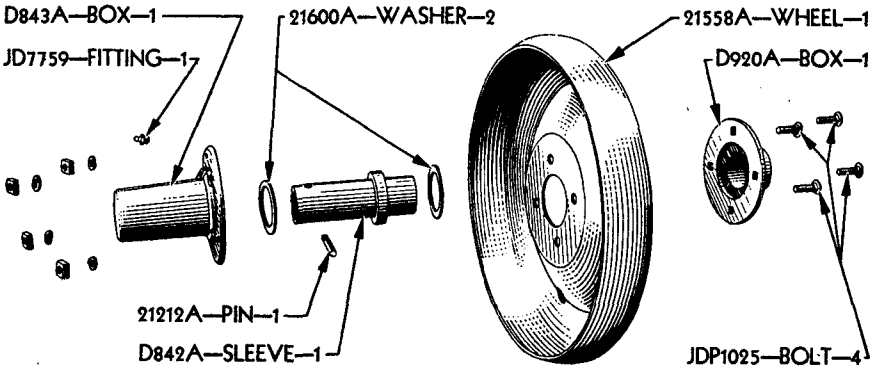

FIGURE 40—REAR WHEEL

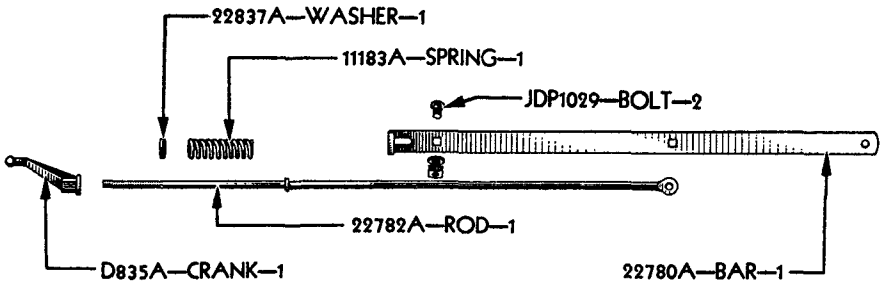

FIGURE 41—CONNECTING BAR

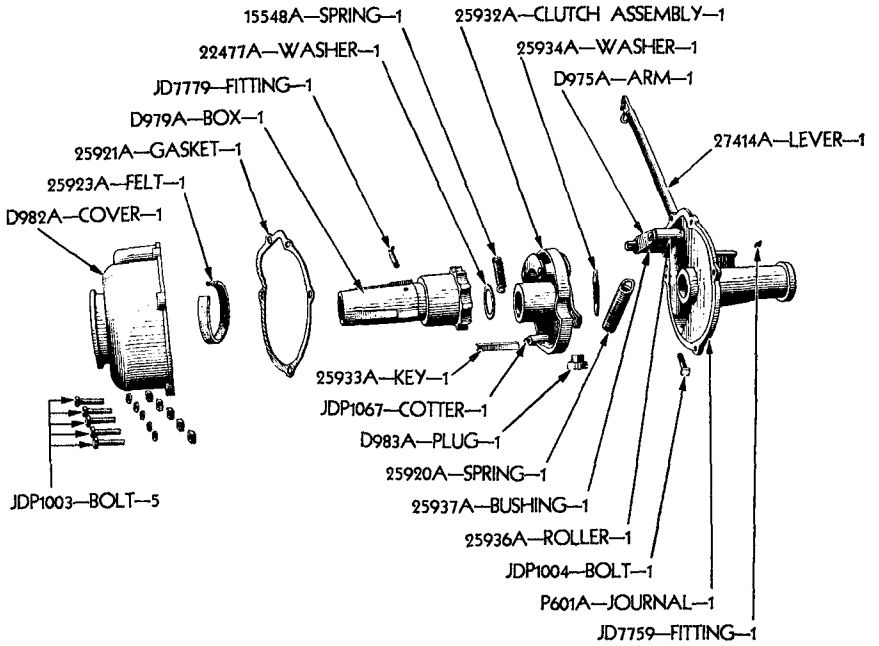

FIGURE 42—LIFTING CLUTCH

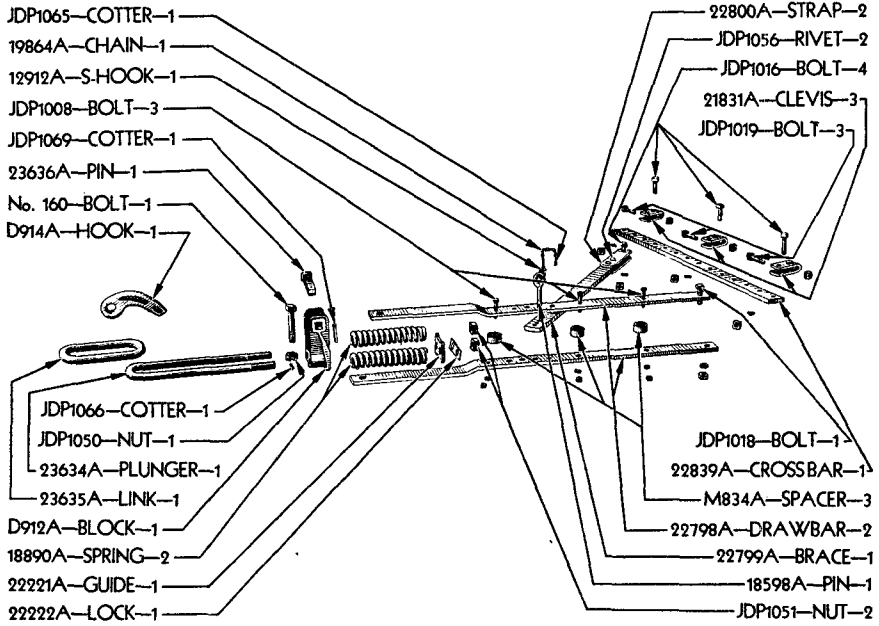

FIGURE 43—HITCH AND SPRING RELEASE

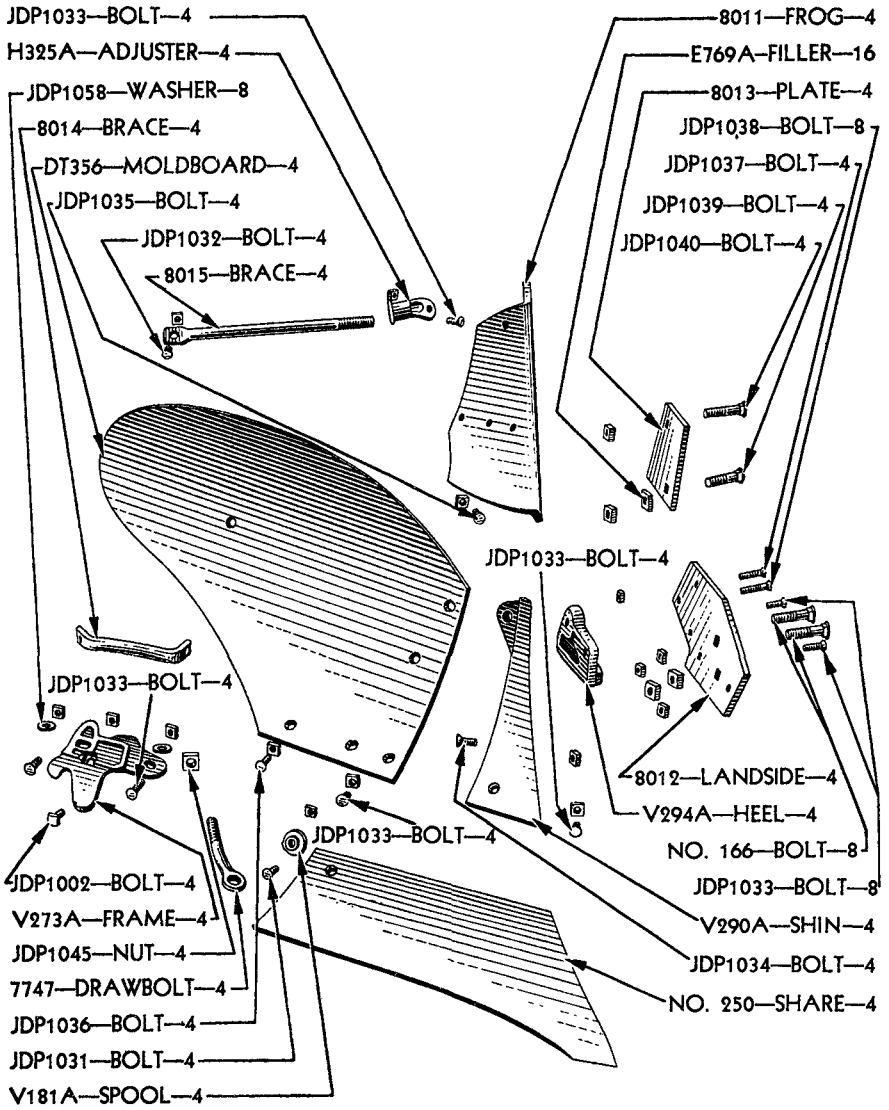

FIGURE 44—PLOW BOTTOMS

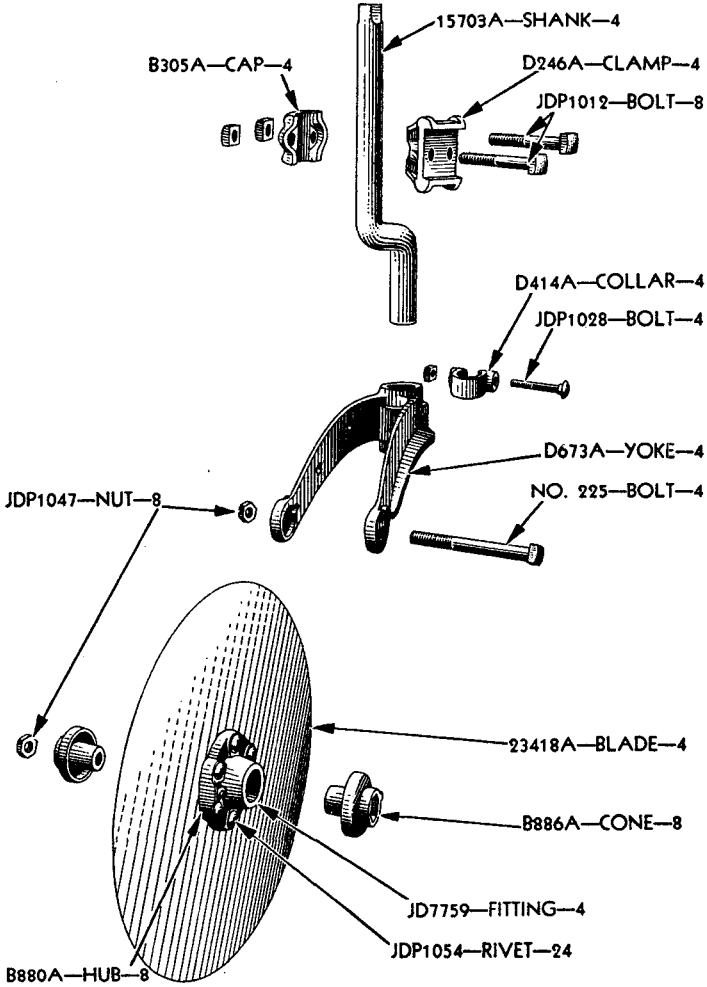

FIGURE 45—ROLLING COULTERS

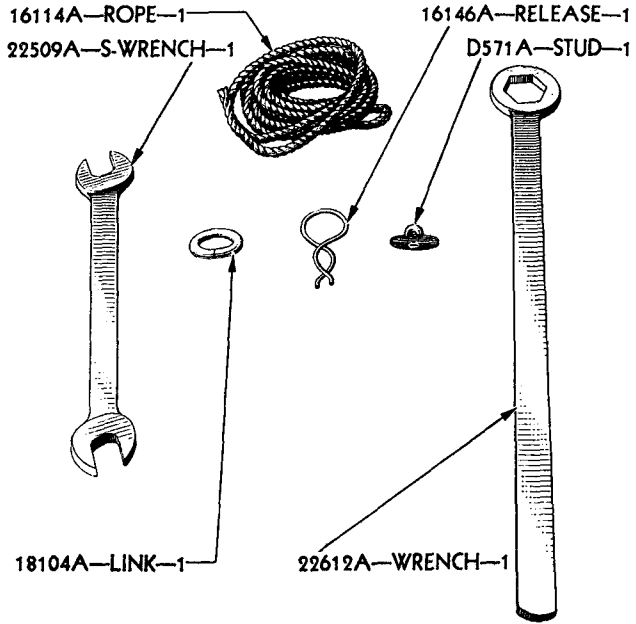

FIGURE 46—TOOLS

SPARE PARTS LIST

Part Number	Description	Page	Quan. Used	Wt.	List Price Each
J 55 A	Spacer, lever.....	27	4	.2	\$0.11
66	Bolt, mach., sq. hd., 5/8" x 3-1/4", with L. W.....	24	1	.5	.09
68	Bolt, mach., sq. hd., 5/8" x 4-1/2", with L. W.....	24	3	.5	.10
129	Bolt, mach., sq. hd., 5/8" x 3-1/2", with L. W.....	24	6	.5	.08
130	Bolt, mach., sq. hd., 5/8" x 3-3/4", with L. W.....	24	1	.5	.08
131	Bolt, mach., sq. hd., 5/8" x 4-1/4", with L. W.....	24	209
132	Bolt, mach., sq. hd., 5/8" x 4-3/4", with L. W.....	24	309
160	Bolt, mach., sq. hd., drilled, 7/8" x 4- 3/4".....	31	1	1.2	.35
162	Bolt, cge., 3/4" x 4-3/4", drilled.....	25	114
163	Bolt, mach., sq. hd., drilled, 5/8" x 2-1/4".....	27	1	.39	.09
166	Bolt, plow, sq. nk., Special, 1/2" x 2-3/4".....	32	8	.22	.11
V 181 A	Spool, share.....	32	4	.1	.11
225	Bolt, plow, sq. nk., 5/8" x 6".....	33	4	.7	.14
D 246 A	Clamp, rolling coulter shank.....	33	4	2.3	1.10
250	Share, soft center steel.....	32	4	14.7	5.10
V 273 A	Frame, share and moldboard.....	32	4	2.4	1.45
V 290 A	Shin, moldboard.....	32	4	6.25	2.00
V 294 A	Heel, landside.....	32	4	4.6	1.40
B 305 A	Cap, rolling coulter shank.....	33	4	.9	.50
H 325 A	Adjuster, moldboard brace.....	32	4	.5	.40
DT 356	Moldboard.....	32	4	34.	14.00
D 414 A	Collar, rolling coulter yoke and shank	33	4	.6	.45
D 522 A	Bushing, for leveling ratchet strap	26	1	.09	.11
D 571 A	Stud, eye.....	34	1	.08	.05
P 601 A	Journal, land axle.....	30	1	27.5	11.00
630	Beam, front.....	24	1	92.4	16.00
631	Beam, second.....	24	1	111.4	19.25
632	Beam, third.....	24	1	133.4	22.50
634	Beam, fourth.....	24	1	98.4	19.00
656	Axle, front furrow.....	25	1	81.	16.25
659	Axle, land.....	26	1	63.	13.50
D 673 A	Yoke.....	33	4	9.	3.45
D 727 A	Pivot, rear wheel lift rod.....	28	1	.6	.60
759	Axle, stub.....	26	1	24.8	7.70
770	Axle, rear.....	28	1	20.	6.25
M 834 A	Spacer, drawbar.....	31	3	.7	.35
D 835 A	Crank, adjusting, rear wheel lift rod	29	1	.8	.55
D 842 A	Sleeve, rear wheel bearing.....	29	1	3.6	1.10
D 843 A	Box, outside wheel.....	29	1	5.8	1.80
D 854 A	Bracket, beam, riveted to beams.....	24	4	18.4	8.00
D 855 A	Cap, for D 854 A.....	24	8	2.4	1.30
D 857 A	Crank, rear axle lift.....	28	1	6.7	3.30
D 859 A	Crank, leveling lever.....	27	1	4.2	2.30
D 860 A	Cap, for D 865 A.....	25	1	2.1	1.20
D 862 A	Roller, rear axle locking.....	28	1	1.9	.65
D 863 A	Sleeve, front furrow wheel bearing... ..	25	1	13.	3.45
D 864 A	Box, outside wheel.....	25	1	10.1	3.00
D 865 A	Box, inside wheel.....	25	1	7.1	2.10
D 866 A	Guide, rope.....	27	1	.27	.25
B 880 A	Hub, rolling coulter.....	33	8	2.5	.85
B 886 A	Cone, rolling coulter hub.....	33	8	1.05	.45
D 912 A	Block, spring plunger.....	31	1	10.25	4.75
D 914 A	Hook, spring release.....	31	1	5.4	4.30

SPARE PARTS LIST

<i>Part Number</i>	<i>Description</i>	<i>Page</i>	<i>Quan. Used</i>	<i>Wt.</i>	<i>List Price Each</i>
D 919 A	Bearing, rear axle.....	28	1	25.	\$11.00
D 920 A	Box, inside wheel.....	29	1	3.2	1.10
D 975 A	Arm, trip lever.....	30	1	1.4	.85
D 976 A	Collar, linchpin.....	26	1	.6	.40
D 977 A	Collar, clutch cover sand.....	26	1	3.7	2.30
D 979 A	Box, land wheel and clutch drum....	30	1	14.66	4.55
D 980 A	Cap, hub.....	26	1	4.4	1.50
D 982 A	Cover, lifting clutch.....	30	1	19.7	5.00
D 983 A	Plug.....	30	1	.1	.05
D 989 A	Sleeve, rear axle.....	28	1	11.94	5.50
JDP 1000	Bolt, mach., sq. hd., 3/8" x 2", with L. W.....	28	1	.1	.02
JDP 1001	Bolt, mach., sq. hd., 3/8" x 2-1/4", with L. W.....	28	1	.11	.02
JDP 1002	Bolt, mach., sq. hd., 7/16" x 1-1/8"	32	4	.09	.03
JDP 1003	Bolt, mach., 7/16" x 1-3/4", with L. W., sq. hd.....	30	503
JDP 1004	Bolt, mach., sq. hd., 7/16" x 2-1/2", no nut.....	30	102
JDP 1005	Bolt, mach., sq. hd., 1/2" x 1", long thread with L. W. (See 22815 A)...	26	1203
JDP 1006	Bolt, mach., sq. hd., 1/2" x 1-3/4", with L. W.....	28	1	.019	.04
JDP 1007	Bolt, mach., sq. hd., 1/2" x 2", with L. W.....	27	2	.21	.04
JDP 1008	Bolt, mach., sq. hd., 1/2" x 2-3/4", with L. W.....	31	3	.24	.04
JDP 1009	Bolt, mach., sq. hd., 5/8" x 1-3/4", with L. W.....	24	208
JDP 1010	Bolt, mach., sq. hd., 5/8" x 2", with L. W.....	26	108
JDP 1011	Bolt, mach., sq. hd., 5/8" x 2-3/4", with L. W.....	26	108
JDP 1012	Bolt, mach., sq. hd., 5/8" x 4-1/4"	33	809
JDP 1013	Bolt, mach., sq. hd., 5/8" x 5" hard.	24	211
JDP 1014	Bolt, mach., sq. hd., 5/8" x 8", with L. W.....	25	3	.86	.12
JDP 1015	Bolt, mach., sq. hd., 5/8" x 9-1/4", with L. W.....	25	3	.95	.13
JDP 1016	Bolt, mach., sq. hd., hard, 3/4" x 2-1/2", with L. W.....	31	4	.65	.13
JDP 1017	Bolt, mach., sq. hd., hard, 3/4" x 2-3/4", with L. W.....	24	114
JDP 1018	Bolt, mach., sq. hd., hard, 3/4" x 3", with L. W.....	31	1	.71	.14
JDP 1019	Bolt, mach., sq. hd., hard, 3/4" x 3-1/4", with L. W.....	24	4	.75	.15
JDP 1020	Bolt, mach., sq. hd., hard, 3/4" x 3-1/2", with L. W.....	24	715
JDP 1021	Bolt, mach., sq. hd., hard, 3/4" x 4", with L. W.....	24	1615
JDP 1022	Bolt, mach., sq. hd., hard, 3/4" x 6-1/4", with L. W.....	28	1	1.11	.18
JDP 1023	Bolt, mach., sq. hd., hard, 3/4" x 7", with L. W.....	28	1	1.19	.19
JDP 1024	Bolt, cge., short neck, 5/16" x 7/8"...	27	4	.04	.01
JDP 1025	Bolt, cge., 7/16" x 1-1/2", with L. W.	29	4	.12	.03
JDP 1026	Bolt, cge., 1/2" x 2", with L. W.....	27	3	.19	.03
JDP 1027	Bolt, cge., 1/2" x 2-1/4".....	27	1	.19	.03
JDP 1028	Bolt, cge., 1/2" x 3-1/4".....	33	4	.25	.03
JDP 1029	Bolt, cge., 5/8" x 1-3/4".....	29	106
JDP 1030	Bolt, cge., 5/8" x 7-3/4", with L. W...	26	312

SPARE PARTS LIST

Part Number	Description	Page	Quan. Used	Wt.	List Price Each
JDP 1031	Bolt, plow, sq. nk., 3/8" x 1-1/4"	32	4	.07	\$0.02
JDP 1032	Bolt, plow, rev. key, 7/16" x 1-1/4"	32	4	.01	.03
JDP 1033	Bolt, plow, rev. key, 7/16" x 1-3/8"	32	24	.12	.03
JDP 1034	Bolt, plow, sq. nk., 7/16" x 1-3/8" ...	32	4	.1	.03
JDP 1035	Bolt, plow, rev. key, 7/16" x 1-1/2"	32	4	.11	.03
JDP 1036	Bolt, plow, rev. key, 7/16" x 1-5/8"	32	4	.11	.03
JDP 1037	Bolt, plow, rev. key, 7/16" x 1-3/4"	32	4	.12	.03
JDP 1038	Bolt, plow, rev. key, 7/16" x 2".....	32	8	.13	.03
JDP 1039	Bolt, plow, sq. nk., 5/8" x 3", hard	32	4	.38	.14
JDP 1040	Bolt, plow, sq. nk., 5/8" x 3-1/4", hard.....	32	4	.4	.14
JDP 1041	Bolt, plow, sq. nk., hard, 5/8" x 5", with L. W.....	24	119
JDP 1042	Bolt, plow, sq. nk., hard, 5/8" x 5- 1/2", with L. W.....	24	120
JDP 1043	Lock washer, 3/4", on spindle, axle, rear.....	28	1	.04	.02
JDP 1044	Lock washer, 1-1/8", on 24077 A....	26	108
JDP 1045	Nut, 5/8", on eyebolts and share drawbolts.....	27	6	.094	.02
JDP 1046	Nut, slotted, 5/8" (for No. 163 bolt)	27	1	.094	.04
JDP 1047	Nut, hex., jam, 5/8" (end of hub bolt)	33	8	.094	.03
JDP 1048	Nut, sq., 3/4".....	28	7	.233	.03
JDP 1049	Nut, slotted, 3/4" (on No. 162 bolt)	25	107
JDP 1050	Nut, hex., slotted, 7/8" (on No. 160 bolt).....	31	1	.25	.09
JDP 1051	Nut, sq., 1" (on plunger, spring)....	31	2	.508	.07
JDP 1052	Nut, hex., jam, 1-1/8".....	26	211
JDP 1053	Nut, hex., 1-1/4".....	26	115
JDP 1054	Rivet, std., oval hd., 3/8" x 1-3/4" (coultter hub to blade).....	33	24	.05	.01
JDP 1055	Rivet, oval head, 7/16" x 1-5/8".....	28	2	.09	.02
JDP 1056	Rivet, oval head, 5/8" x 2-1/2".....	31	2	.3	.05
JDP 1057	Rivet, std., oval hd., 5/8" x 3" (D 854 A to beam).....	24	1206
JDP 1058	Washer, 1" x 15/32" x No. 16 (on bolts in V 273 A).....	32	8	.01	.01
JDP 1059	Washer, 3/4" x 17/32" x No. 16 (on dog, lever).....	27	2	.004	.01
JDP 1060	Washer, 1-1/4" x 5/8" x No. 14 (on dog, lever).....	27	2	.027	.01
JDP 1061	Washer, 2" x 1-5/32" x No. 10.....	26	203
JDP 1062	Cotter, 3/16" x 3/4".....	27	201
JDP 1063	Cotter, 3/16" x 1".....	25	701
JDP 1064	Cotter, 3/16" x 1-1/4", in No. 162 bolt.....	25	101
JDP 1065	Cotter, 1/4" x 1-1/4".....	26	2	.02	.01
JDP 1066	Cotter, 1/4" x 1-1/2".....	31	1	.02	.01
JDP 1067	Cotter, 1/4" x 2-1/4" (in D981 A for spring).....	30	101
JDP 1068	Cotter, 5/16" x 1-3/4".....	26	3	.04	.01
JDP 1069	Cotter, 3/8" x 2".....	31	1	.07	.02
JDP 1070	Cotter, 3/8" x 2-1/2".....	28	2	.07	.02
1295 A	Spring, lever dog.....	27	2	.068	.11
JD 1316	Wheel, front furrow, 32" dia., 6" tire.....	25	1	120.	26.50
JD 1344	Wheel, land, 32" dia., 6" tire.....	26	1	85.	16.00
7747	Drawbolt, share.....	32	4	.62	.25
JD 7759	Fitting, grease, 1/8" x 1/4" strt. (Ale- mite hydraulic No. 1610).....	25	6	.02	.06
JD 7779	Fitting, grease, 1/8" x 2-5/8" strt. (Alemite hydraulic No. 1684).....	26	123

SPARE PARTS LIST

<i>Part Number</i>	<i>Description</i>	<i>Page</i>	<i>Quan. Used</i>	<i>Wt.</i>	<i>List Price Each</i>
8011	Frog, steel.....	32	4	21.	\$6.25
8012	Landside.....	32	4	13.	3.60
8013	Plate, landside extension.....	32	4	4.	.65
8014	Brace, frog.....	32	4	1.1	.40
8015	Brace, moldboard.....	32	4	1.9	.55
11183 A	Spring, rear wheel lift rod.....	29	1	.74	.60
12912 A	S-hook, stop-off pin chain.....	31	1	.031	.05
13826 A	Trigger, lever.....	27	2	.29	.17
15548 A	Spring, inside clutch.....	30	1	.134	.25
15703 A	Shank rolling coultter.....	33	4	10.	1.30
15908 A	Pin, land and furrow axles.....	25	3	.5	.17
16114 A	Rope, 5/16" sisal, 16-ft.....	34	1	.39	.50
16117 A	Box, lever trigger.....	27	2	.06	.11
16146 A	Release, spring, for rope.....	34	1	.06	.11
16311 A	Washer, on rear axle spindle.....	28	1	.08	.04
18104 A	Link, rope.....	34	1	.15	.08
18127 A	Washer, on land axle, right side end, outside.....	26	1	.06	.04
18257 A	Washer, on lift crank pivot pin.....	28	8	.06	.02
18598 A	Pin, stop-off.....	31	1	.79	.30
18890 A	Spring, hitch release.....	31	2	5.75	2.90
19169 A	Washer, on land axle, between D 976 A and D 979 A.....	26	1	.14	.04
19657 A	Washer, on rear axle.....	28	3	.041	.03
19829 A	Rod, leveling lever lower dog.....	27	1	.38	.25
19831 A	Clamp, dog rod.....	27	8	.04	.05
19864 A	Chain, stop-off pin.....	31	1	.13	.05
20705 A	Eyebolt, lever dog.....	27	2	.21	.17
20707 A	Spring, lift, for furrow axle.....	27	1	8.32	2.85
21127 A	Spring, land axle lift.....	27	1	11.38	3.75
21212 A	Pin, in rear wheel sleeve.....	29	1	.06	.04
21558 A	Wheel, rear, pressed steel.....	29	1	15.3	4.70
21595 A	Bushing, for ratchet and rear wheel lift bar.....	26	2	.02	.03
21600 A	Washer, 3" x 2-5/32", on rear wheel sleeve.....	29	2	.17	.04
21625 A	Dog, lever.....	27	2	.45	.25
21626 A	Rod, master lever lower dog.....	27	1	.55	.30
21830 A	Washer, on land, furrow axles.....	25	2	.09	.06
21831 A	Clevis, drawbar hitch.....	31	3	2.8	.95
22215 A	Eyebolt, lift spring.....	27	2	1.2	.30
22221 A	Guide, hitch spring plunger.....	31	1	1.8	.60
22222 A	Lock, hitch spring plunger nut.....	31	1	.13	.11
22266 A	Washer, 4-1/4" x 3-3/8".....	25	4	.09	.08
22268 A	Spring, nut lock, on land axle.....	26	1	1.75	1.85
22477 A	Washer, between D 979 A and D981 A.....	30	1	.3	.06
22509 A	S-wrench.....	34	1	2.06	.95
22612 A	Wrench, box, for 1-1/4" hex. nut.....	34	1	4.	.95
22771 A	Jaw, clevis.....	24	3	12.8	2.95
22772 A	Brace, front beam.....	24	2	10.5	2.55
22773 A	Bracket, front beam brace.....	24	2	5.7	1.95
22774 A	Brace, center beam, first and second beams.....	24	1	15.1	3.40
22777 A	Bar, third beam reinforcing.....	24	1	20.1	4.55
22779 A	Spindle, rear axle.....	28	1	6.	2.50
22780 A	Bar, rear wheel lift rod.....	29	1	8.	2.10
22782 A	Rod, rear wheel lift.....	29	1	6.3	1.95
22783 A	Arm, lift crank.....	28	1	3.6	1.40
22784 A	Strap, lift crank arm.....	28	1	1.4	.55
22785 A	Pin, lift crank pivot.....	28	1	2.5	1.10
22786 A	Pin, rear axle sleeve locking roller... ..	28	1	2.1	.95
22788 A	Post, furrow axle lift spring.....	27	1	3.3	1.20

SPARE PARTS LIST

<i>Part Number</i>	<i>Description</i>	<i>Page</i>	<i>Quan. Used</i>	<i>Wt.</i>	<i>List Price Each</i>
22789 A	Post, land axle lift spring.....	27	1	4.2	\$1.80
22791 A	Brace, rear beam.....	24	1	90.9	12.50
22793 A	Straps, filler, under axle bearings.....	24	7	1.3	.35
22794 A	Bearing, furrow axle, right side.....	25	2	4.1	1.25
22795 A	Bearing, axle.....	25	4	4.4	1.30
22796 A	Bearing, axle.....	25	4	4.7	1.40
22798 A	Drawbar.....	31	2	19.3	3.85
22799 A	Brace, drawbar.....	31	1	20.9	3.75
22800 A	Strap, drawbar brace.....	31	2	3.	.85
22801 A	Hook, land axle lift spring.....	26	1	.84	.40
22803 A	Lever, master and leveling, upper part	27	2	9.1	2.60
22804 A	Rod, upper dog.....	27	2	.68	.25
22805 A	Lever, leveling, lower part.....	27	1	16.3	3.50
22806 A	Strap, leveling lever.....	27	1	10.7	2.70
22807 A	Lever, master, lower part.....	27	1	21.7	4.30
22808 A	Strap, master lever.....	27	1	14.2	3.40
22811 A	Ratchet, master lever.....	27	1	11.1	3.00
22812 A	Pin, in D 863 A.....	25	1	.18	.07
22813 A	Felt strip, in D 860 A.....	25	1	.02	.07
22815 A	Lug, land wheel (with mach. bolt, sq. hd., 1/2" x 1" JDP 1005—long thread, with L. W.).....	26	12	.36	.20
22837 A	Washer, 1/4" x 25/32".....	29	1	.09	.07
22839 A	Crossbar, hitch.....	31	1	30.	4.40
22959 A	Eyebolt, adjusting, right side, for D 919 A.....	28	2	1.	.55
23418 A	Blade, 18", rolling coultter.....	33	4	12.	3.30
23634 A	Plunger, hitch spring.....	31	1	8.8	2.35
23635 A	Link, draft.....	31	1	7.	2.30
23636 A	Pin, spring release hook stop.....	31	1	1.9	.70
24076 A	Eyebolt, adjusting, left side, for D919 A	28	1	1.1	.55
24077 A	Rod, clutch lift.....	26	1	6.8	2.00
24078 A	Swivel, clutch lift rod.....	26	1	1.9	.70
24079 A	Ratchet, leveling lever.....	27	1	12.6	3.40
24080 A	Strap, leveling lever ratchet.....	27	1	6.5	1.95
24132 A	Filler, under 22959 A.....	28	2	.2	.09
25920 A	Spring, trip lever, with D 983 A plug	30	1	.71	.40
25921 A	Gasket, between P 601 A and D 982 A	30	1	.04	.11
25922 A	Seal, dust, under D 980 A.....	26	1	.04	.30
25923 A	Felt strip, in D 982 A.....	30	1	.06	.25
25932 A	Clutch, lifting, assembly.....	30	1	17.13	6.90
25933 A	Key, for lifting clutch.....	30	1	.27	.17
25934 A	Washer, between clutch dog and P 601 A.....	30	1	.6	.09
25935 A	Linchpin, for D 976 A.....	26	1	.12	.04
25936 A	Roller, trip lever.....	30	1	.95	.50
25937 A	Bushing, trip lever roller, inside 25936 A.....	30	1	.19	.05
27414 A	Lever, clutch trip.....	30	1	4.3	1.75