

MHI
Copy 3

FM 4-86

WAR DEPARTMENT FIELD MANUAL

REGRADED UNCLASSIFIED BY

AUTHORITY OF DOD DIR. 5200.1 R

BY Palless ON 011204

SERVICE OF THE PIECE

16-INCH GUN, CASEMATED

REPRODUCTION

FOR HISTORICAL INTEREST

~~RESTRICTED~~ DISSEMINATION OF RESTRICTED MATTER.
The information contained in restricted documents and the essential characteristics of restricted material may be given to any person known to be in the service of the United States and to persons of undoubted loyalty and discretion who are cooperating in Government work, but will not be communicated to the public or to the press except by authorized military public relations agencies. (See also par. 23b, AR 380-5, 15 Mar 1944.)

WAR DEPARTMENT • 10 AUGUST 1944

~~REDACTED~~

FM 4-86

C 1

WAR DEPARTMENT FIELD MANUAL

SERVICE OF THE PIECE 16-INCH GUN, CASEMATED

CHANGES }
No. 1 }

WAR DEPARTMENT
WASHINGTON 25, D. C., 28 December 1945

FM 4-86, 10 August 1944, is changed as follows:

22. OPERATION OF BREECH.

* * * * *

b. *To close the breech by air pressure* (fig. 11), No. 2 first depresses the tripping handle of the holding-down latch with his right foot and then pulls out the handle of the breech-closing valve. The air pressure * * * engaging them in the breech recess. No. 2 uses his * * * the upper cam. No. 1 completes the rotation of the breech. He crosses the * * * variations of matériel.

* * * * *

36. MISFIRES. A misfire occurs * * * and continue fire. If the primer has fired, allow a minimum of 60 seconds before opening the breech and removing the faulty charge. Store the faulty charge separately from other charges.

37. GENERAL.

* * * * *

e. Dirt and grit * * * in the field.

* * * * *

(7) Rifle bore cleaner for cleaning the bore as described in paragraphh 51. If rifle bore cleaner is not available, soda ash will be used for this purpose.

* * * * *

38. FIRING LOCK. a. (Superseded.) Daily, and immediately after firing, wipe clean and oil. Whenever there is evidence of gummy deposits resulting from congealed oil, disassemble the firing mechanism and clean with dry-cleaning solvent. Wipe thoroughly dry; oil prior to assembly. Remove the firing lock from the gun when not in use, place in the box provided, and store in the armament chest.

* * * * *

38.1. FIRING MAGNETO (Added). a. At 2-week intervals remove the cover or case and wipe all accessible parts with a clean, dry, wiping cloth. Apply a thin film of engine oil (SAE 30 above +32° F., or SAE 10 below +32° F.) to all parts of the operating mechanism and replace the cover or case.

b. Exercise the firing magneto daily by giving a few sharp pulls on the handle.

c. The magneto unit inside the case will not be serviced by the using organization. If the magneto fails to generate sufficient current with free-moving mechanical operation, notify the ordnance officer.

40. BREECH AIR PRESSURE (Superseded). To obtain correct breech-closing air pressure, adjust the pressure-reducing valve (fig. 6) on the breech to an operating pressure just sufficient to close the breechblock. The breechblock should be locked manually by means of the breech-operating lever. The required air pressure varies with the temperature, the closing cylinder springs, and the condition of the breech mechanisms. Too high a pressure slams the breechblock into the breech recess and results in undue wear on the threads of the breechblock and breech recess. Adjustment of the breech-closing air pressure should be made by qualified ordnance personnel.

51. (Superseded) CARE OF BORE AND BREECH MECHANISM. a. Bore. The following materials and cleaning and preserving procedures will be used on the bore in order of indicated preference. Oils to be applied after cleaning will be those prescribed by applicable War Department Lubrication Orders and TM 9-471 for specific temperature ranges except that in areas of excessive moisture, preservative lubricating oil (medium) may be used where engine oil (SAE 30) is prescribed.

(1) *Rifle bore cleaner.* (a) After firing, as soon as the tube has cooled to the point where it can be touched by the bare hand and on 2 consecutive days thereafter, thoroughly clean the bore with rifle bore cleaner, making sure that all surfaces, including the rifling, are well coated. Do not wipe dry.

(b) On the third day after firing, clean the bore with rifle bore cleaner. If the piece will probably be fired within the next 24 hours, do not wipe dry. If the piece will not be fired within the next 24 hours, wipe dry and coat with the prescribed oil.

(c) During active periods when the gun is not being fired, daily renew the oil film in the bore. Weekly, clean with rifle bore cleaner, wipe dry, and oil.

(2) *Soda ash.* (a) Prepare a solution of $\frac{1}{2}$ pound of soda ash to each gallon of warm water. In temperatures below $+32^{\circ}$ F., add the type and amount of antifreeze prescribed in TM 9-850, if the tube to be cleaned is cold.

(b) As soon as possible after firing and on 3 consecutive days thereafter, thoroughly clean the bore with the soda ash solution. Rinse with clear, warm water and wipe dry. Coat with the prescribed oil.

(c) When the piece is not being fired, renew the oil film daily. Every fifth day, clean the bore with dry-cleaning solvent or rifle bore cleaner, if available. Wipe dry and reoil.

(3) *Soap.* (a) Use castile or issue soap.

(b) Prepare a sponging solution by shaving 1 pound of soap into 4 gallons of water. If possible, warm the water to facilitate dissolving the soap. In temperatures below $+32^{\circ}$ F., add the type and amount of antifreeze prescribed in TM 9-850, if the tube to be cleaned is cold.

(c) Follow the same cleaning, drying, and oiling procedure prescribed for the soda ash solution.

Caution. When issue soap is used, the bore must be thoroughly rinsed after cleaning, as the soap may contain free caustic which will cause corrosion if it is not completely removed.

(4) *Hot water.* (a) As a temporary measure after firing, the bore may be cleaned while still hot by swabbing with quantities of hot water. This method will be used only when rifle bore cleaner, soda ash, or soap is not available. Extreme care must be taken to thoroughly dry the bore after cleaning with hot water. A coating of oil will be applied immediately thereafter to prevent rusting.

(b) Swabbing with hot water may not remove all of the primer salts or powder residue. It is most important, therefore, that the bore be cleaned as soon as possible in accordance with (1), (2), or (3) above.

b. *Breech mechanism.* (1) After firing, and on 3 consecutive days thereafter, disassemble the obturator spindle from the breechblock and clean the breech recess, breechblock, and obturator parts (except the gas check pad) with the same solution used in cleaning the bore. Wipe thoroughly dry and oil, first rinsing the parts with clean water if solutions other than rifle bore cleaner are used in the cleaning process.

(2) During active periods when the gun is not being fired, daily renew the oil film on the interrupted threads of the breech-

block, in the breech recess, and on all exposed metal surfaces. Weekly, disassemble the obturator spindle from the breechblock, clean all parts, and reoil. To remove gummy deposits, clean with dry-cleaning solvent and wipe thoroughly dry before oiling.

(3) Prior to assembly, wipe clean the gas check pad with a clean, dry cloth. At no time should dry-cleaning solvent, bore cleaning solutions, or oil be applied to the gas check pad.

[AG 300.7 (21 Dec 45)]

BY ORDER OF THE SECRETARY OF WAR:

DWIGHT D. EISENHOWER

Chief of Staff

OFFICIAL:

EDWARD F. WITSELL

Major General

Acting the Adjutant General

DISTRIBUTION:

AAF (2); AGF (40); ASF (2); Arm & Sv Bd (1);
Def Comd (5); Tech Sv (2) except 9 (10); SVC
1-3, 9 (5); HD (5); Sp Sv Sch (1) except 4
(100); USMA (1); ROTC 4 (1); T/O & E:
4-62 (2); 4-66 (2); 4-67 (15); Special distribu-
tion.

Refer to FM 21-6 for explanation of distribution
formula.

WAR DEPARTMENT FIELD MANUAL
FM 4-86

SERVICE OF THE PIECE
16 - INCH GUN
CASEMATED



WAR DEPARTMENT • 10 AUGUST 1944

RESTRICTED. DISSEMINATION OF RESTRICTED MATTER.—The information contained in restricted documents and the essential characteristics of restricted material may be given to any person known to be in the service of the United States and to persons of undoubted loyalty and discretion who are cooperating in Government work, but will not be communicated to the public or to the press except by authorized military public relations agencies. (See also par. 236, AR 380-5, 15 Mar 1944.)

Army Field Printing Plant, C.A.S.
Fort Monroe, Va.—1944

WAR DEPARTMENT,
WASHINGTON 25, D.C., 10 August 1944.

FM 4-86, Coast Artillery Field Manual, Service of the Piece, 16-inch Gun, Casemated, is published for the information and guidance of all concerned.

[A.G. 461 (10 Jul 44).]

BY ORDER OF THE SECRETARY OF WAR:

G. C. MARSHALL,
Chief of Staff.

OFFICIAL:

J. A. ULIO,
*Major General,
The Adjutant General.*

DISTRIBUTION:

Island Comds (5); Base Comds (5); Sv C (10); Depts (5); Def Comds (5); Sectors (5); Sub-Sectors (5); HD (5); IR 4 (5); IBn 4 (5); IC 4 (25); Arm & Sv Boards (2); Posts, Camps & Sta having Seacoast Arty units (1); Coast Arty ROTC units (1); Gen & Sp Sv Sch (50) except Coast Arty Sch (100); C of Tech Sv (2).

IR 4: T/O & E 4-62, Hq & Hq Btry, CA Gp (HD).

IBn 4: T/O & E 4-66, Hq & Hq Det, CA Bn (HD).

IC 4: T/O & E 4-67, CA Btry (Gun) (HD);
Types BM, BN and BO.

For explanation of symbols, see FM 21-6.

CONTENTS

SECTION I. GENERAL.	<i>Paragraph</i>	<i>Page</i>
Scope	1	1
References	2	2
 II. ORGANIZATION.		
Gun section	3	3
Gun squad	4	3
Ammunition squad	5	3
Formation	6	3
 III. DUTIES OF PERSONNEL.		
Battery executive	7	6
Assistant battery executive	8	7
Chief of section	9	7
Gun commander	10	8
Gun pointer	11	13
Elevation setter	12	13
Chief of breech	13	14
Telephone operator	14	14
Chief of ammunition	15	14
Breech detail	16	17
Ammunition squad	17	18
Artillery mechanic	18	18
Power plant operators	19	19
 IV. NOTES ON SERVICE OF THE PIECE.		
General	20	20
Firing lock	21	20
Operation of breech	22	24

CONTENTS—Contd.

SECTION IV. NOTES—Contd.	<i>Para- graph</i>	<i>Page</i>
Loading	23	26
Traversing mechanism ..	24	30
Elevating mechanism	25	32
Recoil parts lock	26	33
Motors	27	34
Air compressor	28	35
Firing the piece	29	37
V. SAFETY PRECAUTIONS.		
General	30	38
The command CEASE FIRING	31	38
Primers	32	38
Powder charge	33	39
Powder chamber	34	39
Poor visibility	35	39
Misfires	36	40
VI. CARE AND ADJUSTMENT OF MATERIEL.		
General	37	41
Firing lock	38	42
Obturator	39	44
Breech air pressure	40	45
Air compressor	41	45
Elevating brake	42	45
Antifriction device	43	47
Recoil mechanism	44	49
Recuperator system	45	51
R e c o i l a n d recuperator liquid	46	58
Carriage	47	58
Power rammer	48	59
Hydraulic speed gear	49	61
Sponging solution	50	62
Care of bore	51	62
Azimuth and elevation data indicators	52	63

CONTENTS—Contd.

SECTION VII. DEMOLITION OF EQUIP- MENT.	<i>Para- graph</i>	<i>Page</i>
General principles	53	66
Priority of destruction ...	54	67
Tube	55	67
Breech	56	68
Recoil mechanism and car- riage	57	69
Power equipment	58	69
Telescopes and observation instruments	59	69
Plotting room equipment ..	60	69
Ammunition	61	69
Fire control and observation stations; ammunition magazines	62	70
 APPENDIX I. LIST OF REFERENCES		 71
 II. STATISTICAL DATA		 73
 III. DRILL TABLE		 75

RESTRICTED

SECTION I

GENERAL

1. SCOPE. a. This manual prescribes the service of the piece for all 16-inch casemated guns (fig. 1). Most of the guns are the Mk. II M1 Navy type on the M1919M1, M2, M3, M4, or M5 carriage. However, some of the M1919MII and M1919MIII Army type guns on the M1919 carriage have been modified and casemated.

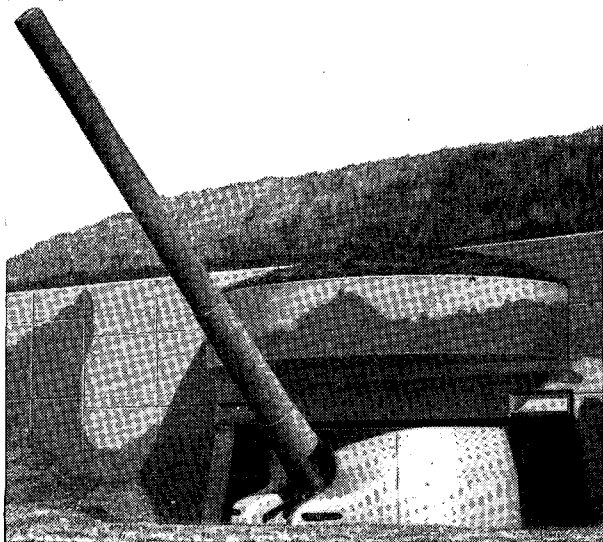

Figure 1. 16-inch casemated gun.

Note. For definitions of military terms not contained in this manual, see TM 20-205.

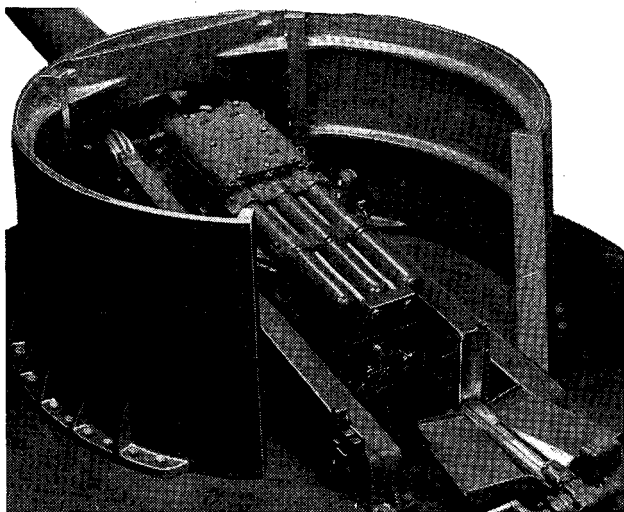

Figure 2. 16-inch gun with shield, rear view.

b. This manual is based on the Mk. II M1 Navy gun on the M4 carriage. In some cases, differences between this carriage and the M1919 and M1919M1 carriages have been noted. Further information on the operation of the guns on the M1919 and M1919M1 carriages may be obtained from local ordnance, FM 4-85, and from references listed in appendix I. All figures in this manual are of the M4 carriage.

c. The service of the piece as described herein is intended as a guide for the battery commander. Changes in the details of the service of the piece may be made to meet local conditions.

2. REFERENCES. The references listed in appendix I should be consulted, especially those pertaining to ammunition, and to the operation, care, and maintenance of materiel.

SECTION II

ORGANIZATION

3. GUN SECTION. Each gun emplacement is manned by a section consisting of 42 enlisted men. The section is commanded by a chief of section and is divided into a gun squad of 12 men and an ammunition squad of 29 men.

4. GUN SQUAD. The gun squad consists of the gun commander, gun pointer, elevation setter, chief of breech, telephone operator, and 7 cannoners numbered from 1 to 7. Men are assigned to permanent positions according to their aptitudes but should be interchanged frequently in drill positions in order to develop flexibility and facilitate replacement.

5. AMMUNITION SQUAD. The ammunition squad consists of a chief of ammunition and 28 cannoners (ammunition handlers) numbered 8 to 35 inclusive. This squad is divided by its chief into details for the service of powder and projectiles and for miscellaneous duties required by local conditions.

6. FORMATION. At the command **GUN SECTION, FALL IN**, each gun section assembles in two ranks at close interval, facing the chief of section. To form the section, the chief of section takes post three paces in front of and facing where the center of the section is to rest. From right to left, the front rank consists of the gun commander, gun pointer, chief of breech, Nos. 2, 4, 6, chief of ammunition,

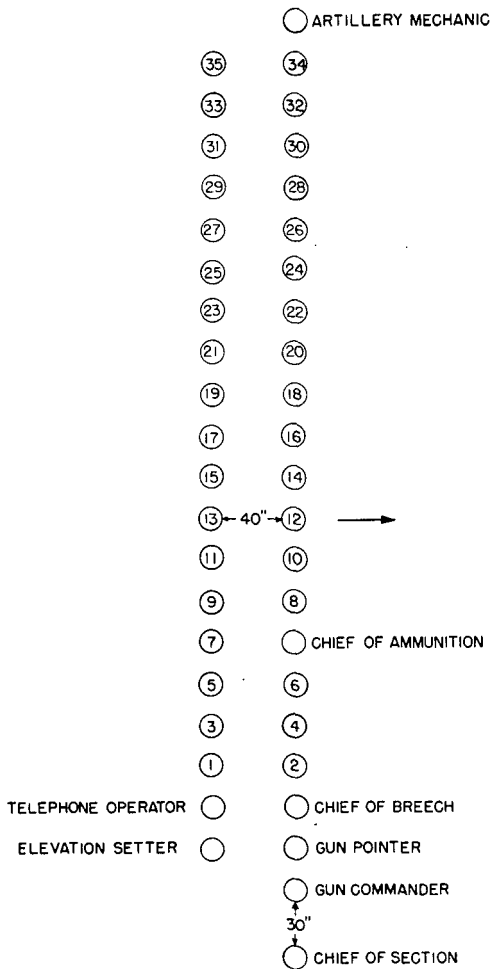

Figure 3. Formation of gun section.

and all the remaining even numbered cannoneers. In the same order the rear rank forms as follows: elevation setter, telephone operator, and all odd numbered cannoneers. After forming the gun section, the chief of section takes post in the front rank 30 inches to the right of the gun commander (fig. 3). When the artillery mechanic is present, he forms on the extreme left of the front rank.

SECTION III

DUTIES OF PERSONNEL

7. BATTERY EXECUTIVE. a. The battery executive commands the firing section of the battery and is in charge of the gun emplacements and accessories. He is responsible to the battery commander for the—

(1) Training and efficiency of the personnel of the firing section.

(2) Condition of the materiel and ammunition under his charge.

(3) Observance of all safety precautions pertaining to the service of the piece.

(4) Police of all emplacements.

(5) Camouflage of all emplacements.

(6) Technical handling of the guns.

(7) Selection of positions for the automatic weapons as well as the supervision of their emplacement and employment.

b. Twice daily, morning and evening or whenever necessary, he inspects the materiel under his charge and personally checks the adjustment of all pointing devices. He tests the operation of all elevating, traversing, air pressure, and breech mechanisms. He checks the safety features of all firing mechanisms. He checks the filling of the recoil cylinder and recuperator cylinders, the air pressure in the recuperator cylinders, and the air pressure in the air storage tanks.

c. He receives the reports of the assistant battery executive, chiefs of section, or gun commanders, and reports to the battery commander,

“Sir, guns in order,” or reports defects which he is unable to remedy without delay.

d. During action he exercises general supervision over the loading and pointing of the guns. When firing on the time interval bell, if for any reason he desires to hold fire for one firing interval, he commands: RE-LAY, and reports his action to the battery commander. Should circumstances, in his opinion, make it unsafe to fire, he commands: CEASE FIRING, and reports his action to the battery commander.

e. At the conclusion of drill or firing, the battery executive commands: REPLACE EQUIPMENT, inspects the emplacement, and reports to the battery commander stating any deficiencies affecting the readiness of the battery for subsequent action. He supervises the cleaning and preparation of the guns for the next firing.

8. ASSISTANT BATTERY EXECUTIVE. The assistant battery executive performs the duties of the battery executive pertaining to the emplacement or emplacements to which he is assigned.

9. CHIEF OF SECTION. a. The chief of section (noncommissioned officer) is in charge of the gun section and emplacement. In the absence of the assistant battery executive, the chief of section performs his duties. In addition, he supervises the service of the piece and service of ammunition, and personally directs the work of care and preservation at the emplacement to which his section is assigned. He is responsible to the officer in charge of the emplacement for the—

(1) Training and efficiency of the personnel of his section.

(2) Condition of the materiel under his charge.

(3) Observance of all safety precautions at the emplacement.

(4) Police of the emplacement.

(5) Preparation of the piece for firing, including camouflage discipline and gas discipline when necessary.

b. His presence in no way relieves the gun commander of his responsibilities. However, as a means of expediting firing and insuring safety, the chief of section coordinates the actions of the gun squad and ammunition squad, making certain that the chief of ammunition receives all commands and necessary information. Also, when the gun commander is required to remain at his post during firing, the chief of section makes such checks of materiel, auxiliaries, and personnel as may be necessary to insure proper functioning and safety. In an emergency, he is prepared to assume command of the gun squad and to designate replacements wherever necessary.

c. When the command REPLACE EQUIPMENT has been given, he supervises the work of the gun squad and ammunition squad.

d. Twice daily, at the direction of the assistant battery executive or battery executive, he forms his gun section at the emplacement and orders the gun commander and chief of ammunition to post their details and examine gun and equipment. He sees that servicing equipment is kept convenient to the individual posts, so that it is necessary only for members of the gun section to check the items for presence and place them for use. He receives the reports of the gun commander and the chief of ammunition and reports to the officer in charge of the emplacement, "Sir, No. _____ in order," or any defects which he is unable to remedy without delay.

10. GUN COMMANDER. a. The gun commander (noncommissioned officer) is in command of the gun squad. He is responsible to the chief of section for the—

(1) Training and efficiency of the personnel of his squad.

(2) Condition of the materiel under his charge.
(3) Preparation of the piece for firing, including camouflage discipline and gas discipline when necessary.

(4) Firing the piece.

(5) Observance of all safety precautions pertaining to the service of the piece.

(6) Police of the emplacement.

b. Having posted his detail (fig. 4) and given the command EXAMINE GUN, he personally makes an inspection of the gun, carriage, and other materiel, giving particular attention to the recoil and recuperator systems, firing mechanism, recoil parts lock and other safety devices, and the oiling of the various bearings.

c. He receives the reports of the various details of the gun squad and reports to the chief of section, "No. _____ in order," or any defects he is unable to remedy without delay.

d. It is not necessary when going into action to go through the commands of DETAILS, POSTS or EXAMINE GUN. The sounding of the alert signal is sufficient to post the details. The gun commander can check his detail, especially at night, by the command CALL OFF, at which the cannoneers call off their titles and numbers in succession. He can check their readiness for action by the command REPORT. The command EXAMINE GUN is unnecessary since guns and servicing equipment are maintained in a constant state of readiness, insured by two inspections daily.

e. When necessary during preparations for drill or action, the gun commander informs the chief of ammunition as to the projectile, fuze, and powder charge to be used.

f. At the command TARGET, he repeats the command and the target designation. In case II firing he assists the gun pointer in getting on the correct target. As soon as the gun pointer is on target, the gun commander reports through the battery com-

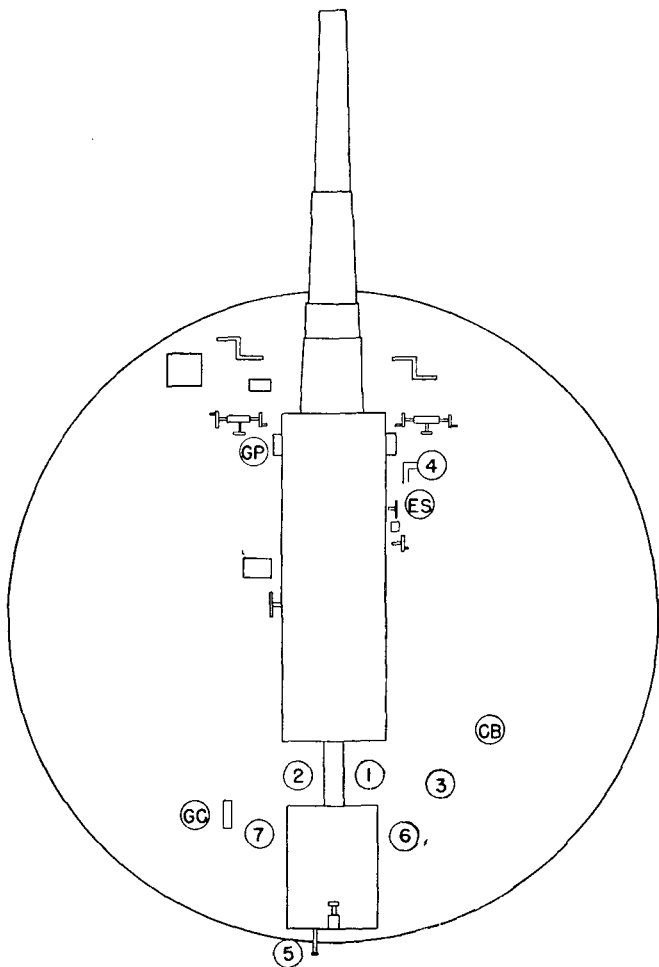

Figure 4. Posts of members of the gun squad at completion of the command DETAILS, POSTS.

mander's telephone operator, "Sir, No. _____ on target."

g. At the command LOAD, he repeats the command, supervises the loading of the piece, and stands ready to fire the gun or give the command to fire.

h. At the command COMMENCE FIRING, the gun commander performs duties as follows:

(1) In case III firing, the gun commander fires the gun or gives the command FIRE on the next time interval, or, if the battery is using a gun data computer, as soon as the gun is ready. His procedure is determined by the following:

(a) In case III firing, when the gun is provided with a magneto-transformer system of power, he fires the gun by pressing the gun commander's push button after the elevation setter announces, "Set."

(b) In case III firing, if the gun is not provided with a magneto-transformer system of power, he commands: FIRE, after the elevation setter announces, "Set." The brake operator then fires the gun with the magneto at the right side of the gun.

(2) In case II firing, when the gun is provided with a magneto-transformer system of power, the gun commander, after the elevation setter announces, "Set," presses the safety push-button switch and calls, "Ready." The gun pointer fires as soon as he is on the target.

(3) In case II firing, if the gun is not provided with a magneto-transformer system of power, he calls, "Ready," after the elevation setter announces, "Set." The gun pointer fires the gun with the magneto at the left side of the gun when he is on target.

i. When firing on the time interval signal, the gun commander sees that the piece is fired immediately upon the proper signal, safety precautions permitting. He commands: RE-LAY, in case his gun is not ready to fire when the time interval

sounds. He repeats the command RE-LAY, when it is given by the officer in charge of emplacement.

j. During the firing, the gun commander pays particular attention to the action of the gun in recoil and counterrecoil in order that a loss of recoil liquid by leakage may be observed in time to be corrected. After the first and second rounds, he sees that the liquid indicators, located on the recuperator cylinders, are checked and that the piston rod nut washers are within limits (par. 45). Thereafter, he sees that the indicators are checked frequently.

k. He commands: CEASE FIRING when the number of shots specified have been fired. He repeats the command CEASE FIRING when it is received. At the conclusion of a series of shots, he reports through the battery commander's telephone operator, "Sir, No. _____ (so many) rounds fired." Should the gun be loaded at the command CEASE FIRING, he causes all personnel to keep away from the gun commander's push button. If the gun is equipped with firing magnetos, he causes all personnel to keep away from them. If firing by lanyard, he causes the lanyard to be detached. Under the supervision of the battery executive, the gun may be unloaded by firing the projectile after the field of fire is clear. When dummy ammunition is used, the gun commander commands: UNLOAD, and supervises the unloading.

l. At the command SUSPEND FIRING, the gun commander repeats the command, and if the piece is unloaded, causes it to be loaded and holds fire until he receives the command RESUME FIRING.

m. In case of a misfire, he reports to the executive or assistant executive, "No. _____, misfire," and the cause of the misfire if known. He sees that the precautions described in paragraph 36 are observed.

n. At the command REPLACE EQUIPMENT, he repeats the command; supervises the replacing of all equipment; sees that the air compressor is

stopped or placed on automatic operation if conditions warrant (pars. 28 and 41); sees that all materiel is properly secured and the emplacement policed; and then, unless otherwise directed, forms his squad and reports to the chief of section.

11. GUN POINTER. The gun pointer is charged with the duty of pointing the piece in direction. He is responsible to the gun commander for the proper operation, care, and adjustment of the azimuth data indicator, traversing mechanism (fig. 13), and the telescope and telescope mount. For detailed duties of the gun pointer, see the drill table, appendix III.

12. ELEVATION SETTER. a. The elevation setter is charged with the duty of setting the piece in elevation. He is responsible to the gun commander for the proper operation, care, and adjustment of the elevation data indicator and the elevating mechanism (fig. 14). For detailed duties of the elevation setter, see the drill table, appendix III.

b. The elevation brakes on the gun must be set before the piece can be fired. Setting the elevation brakes will prevent movement of the mechanical pointers. In order that the gun may be fired at the instant the electrical and mechanical pointers of the elevation data indicator are in coincidence, and with the elevation brakes of the gun set, the procedure will be as follows:

(1) The elevation setter notes with care the direction and rate of movement of the electrical pointers.

(2) After receiving the command ELEVATE, he brings the gun up but does not match the pointers. Instead, he sets the mechanical pointer ahead an amount depending upon the rate of change of the elevation and commands: ELEVATION.

(3) On this command the brake operator drops the brake levers, setting the brakes.

(4) When the electrical pointers of the elevation data indicator match the mechanical pointers, the elevation setter calls, "Set."

(5) The gun is fired in accordance with directions given in paragraphs 10 and 29 and in the drill table, appendix III.

(6) To achieve good results a considerable amount of training in this procedure will be required.

13. CHIEF OF BREECH. The chief of breech is responsible to the gun commander for the efficiency of the breech and rammer detail and for the condition, serviceability, and operation of the breech and rammer mechanisms. He is responsible for the condition of the chamber and bore of the gun; for the observance of safety precautions that pertain to his detail; and for the proper loading of the piece. He pays particular attention to the seating of the projectile and sees that the igniter is on the rear end of the powder charge and placed in the chamber so that the mushroom head of the closed breechblock will touch it. For detailed duties of chief of breech, see the drill table, appendix III.

14. TELEPHONE OPERATOR. The telephone operator is charged with the duty of receiving and transmitting all messages passing between the battery commander and the officer or noncommissioned officer in charge of the emplacement and of keeping such records as may be directed. For detailed duties of the telephone operator, see the drill table, appendix III.

15. CHIEF OF AMMUNITION. a. The chief of ammunition is responsible for the—

(1) Efficiency and training of the personnel under his charge.

(2) Care and preservation of the equipment used in the handling of ammunition.

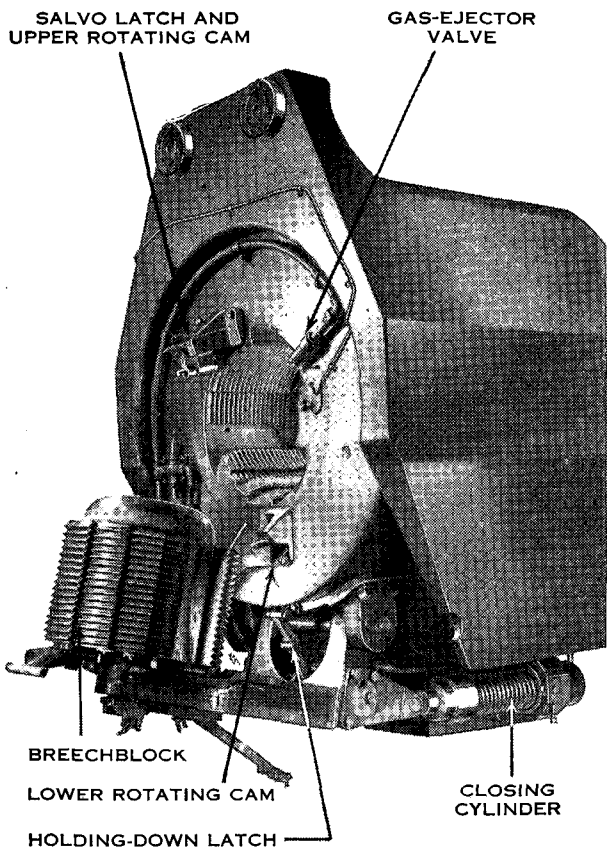

Figure 5. Breech of gun, breechblock open.

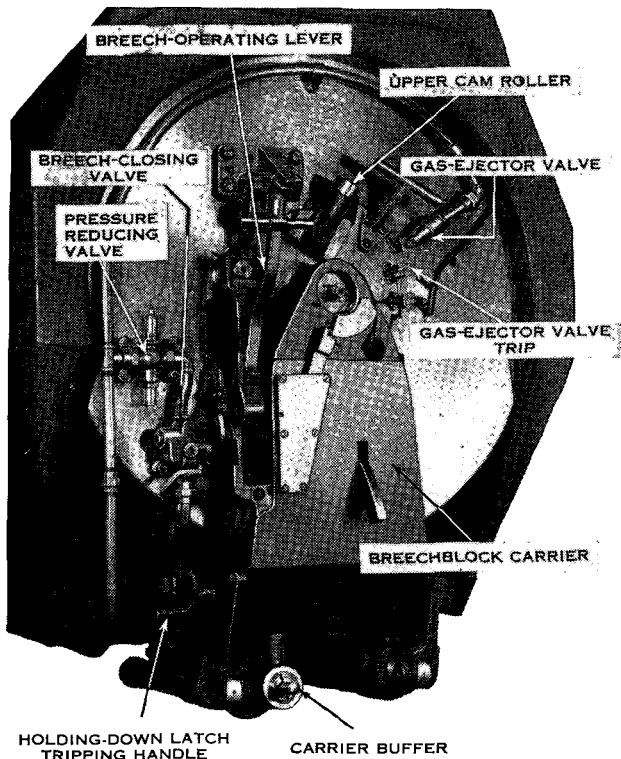

Figure 6. Breech of gun, breechblock closed.

(3) Observance of all safety precautions in the care and service of ammunition.

(4) Security and careful handling of the ammunition and its protection against water, dampness, fire, and the direct rays of the sun.

(5) Police of projectile room, powder magazine, and the galleries.

b. He keeps a record of all ammunition received and used by his gun, exercising particular care that projectiles and fuzes are listed under proper name and type.

c. He keeps the chief of section informed regarding ammunition on hand, checks the weight of projectiles, and reports defects found in the ammunition.

d. He keeps a thermometer in a selected powder container and reports the temperature of the powder when required. Where powder has been stored for at least 2 weeks in a service magazine, the temperature of the magazine may be taken as the powder temperature. This temperature should be taken immediately upon opening the magazine.

e. Having posted his detail and given the command EXAMINE EQUIPMENT, he inspects the materiel under his charge, gives the necessary instructions for preparing ammunition and equipment for firing or drill, and reports to the chief of section, "Ammunition service in order," or reports any defects he cannot remedy without delay.

f. It is not necessary when going into action to go through the commands of DETAILS, POSTS or EXAMINE EQUIPMENT. The sounding of the alert signal is sufficient to post the details. The chief of ammunition can check his detail, especially at night, by the command CALL OFF, at which the cannoneers call off their numbers in succession. The command EXAMINE EQUIPMENT is unnecessary since equipment is maintained in a constant state of readiness, insured by two inspections daily.

g. For additional duties of the chief of ammunition, see drill table, appendix III.

16. BREECH DETAIL. The breech detail, Nos. 1 to 7 exclusive of No. 4, are charged with the duties of loading the gun. Each cannoneer is responsible to the chief of breech for the proper and precise execution of the duties outlined in the drill table, appendix III. Each cannoneer is responsible for the care, adjustment, and operation of the mechanism and equipment with which he works.

17. AMMUNITION SQUAD. a. The ammunition squad, under the supervision of the chief of ammunition, is charged with the duty of supplying to the gun position ammunition in sufficient quantities to sustain fire at the maximum rate.

b. The 29 enlisted men allotted to this squad will not be enough to supply ammunition to the gun in sufficient quantities for maximum rate of fire over a long period of time. In such a case, it will be necessary to detail at least 10 additional men to the ammunition squad.

c. The ammunition detail will be divided into groups with the following duties:

(1) Nos. 8 and 9 open powder cans and place powder charges on the ammunition trucks. They remove the powder charges from the containers one at a time as needed.

(2) Nos. 10 to 21 inclusive, working in pairs, move chain hoists with shot tongs (ammunition trucks if used) into the projectile room, obtain a projectile, deliver it to the gun, and return for another.

(3) Nos. 22 to 35 inclusive, working in pairs, obtain ammunition trucks and line up in the gallery. They move into the powder magazine, obtain a powder charge, deliver it to the gun, and return for another.

(4) See drill table, appendix III.

18. ARTILLERY MECHANIC. a. The artillery mechanic is a member of the maintenance section of the battery. He makes minor repairs and adjustments, assisted by members of the gun section. The artillery mechanic is the custodian of the storeroom and supplies pertaining to the gun emplacements. He or his assistant issues such equipment (tools, oils, paints, and cleaning materials) to the members of the gun sections as may be necessary for the service and care of the guns and accessories.

b. The artillery mechanic will perform the following duties daily:

(1) Check the amount of oil in the recoil cylinder and add more if necessary. (See par. 44.)

(2) Check the air pressure and liquid in the recuperator cylinders. (See par. 45.)

(3) Examine all speed gears and their motors to see that they are operating properly.

(4) Check trunnion-bearing clearance on mounts having an antifriction device. (See par. 43.)

(5) Check air pressure system, including the gas ejector and breechblock closing mechanism. (See par. 41.)

(6) Check elevating brakes to insure that they are working properly.

19. POWER PLANT OPERATORS. a. The three power plant operators are members of the power plant detail of the battery. They are responsible for the operation and maintenance of the power plant and all associated equipment.

b. The power plant operators will exercise the power plant daily and will keep a record of hours of operation, loads, fuel consumption, and all other records necessary.

SECTION IV

NOTES ON SERVICE OF THE PIECE

20. GENERAL. a. Conduct the service of the piece with dispatch and precision and with as few orders as possible. Except for the necessary orders, reports, and instructions, permit no talking. All cannoneers will change positions as rapidly as practicable. Give commands in the prescribed forms (FM 4-5). Substitute signals for commands whenever practicable (FM 4-20).

b. Loading the piece with dummy ammunition and pointing at moving targets are the normal practice at drill. Use drill primers or fired service primers.

c. When there is a lull in the firing or drill, each member of the gun section will inspect, clean, and place in the best condition possible, the materiel under his charge. After this has been completed the officer in charge of each gun emplacement, the chief of section, or the gun commander may conduct instructions at the gun which will be of interest to the entire gun section.

d. Power failures and damage or malfunctioning of parts of the piece should be anticipated. Instruct the personnel in the proper procedure in case of such failures. Conduct drills in which failures are simulated. Make preparations for the replacement of casualties for every position and simulate casualties during gun drills.

21. FIRING LOCK. a. The firing lock is automatically opened and closed when the breech-block is operated; that is, when the breech-operat-

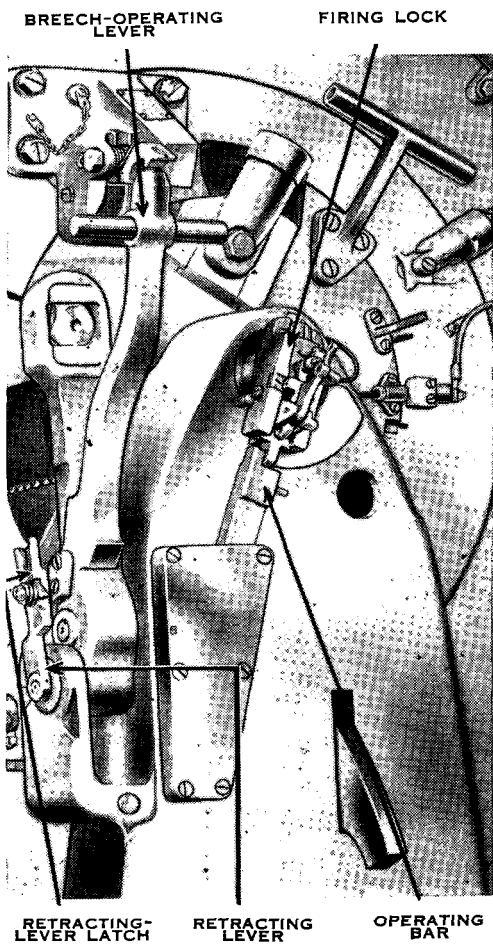

Figure 7. Firing lock operating parts.

ing lever (fig. 7) is raised or lowered, a system of levers and cranks manipulates the firing lock operating bar and firing lock slide. To operate the firing lock slide by hand (independent of the breech-operating lever) so that the primer may be inserted, it is necessary to pull back on the firing lock retracting-lever latch (fig. 8).

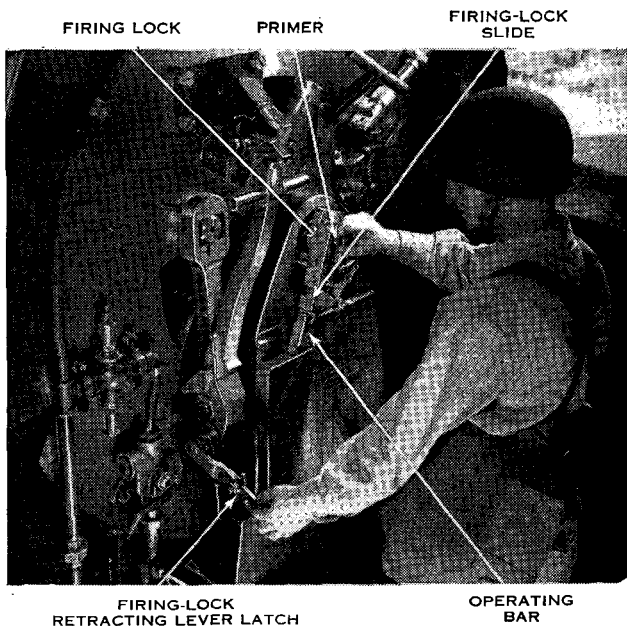

Figure 8. Inserting the primer.

b. The firing lock is assembled to the obturator spindle by inserting it on the spindle with the slide to the left and in the open position. The firing lock is then rotated 90° in a clockwise direction and attached to the firing lock operating bar.

c. The piece may be fired either by electricity or by lanyard, as the firing lock is designed to be used with combination percussion-electric primers.

d. In firing by lanyard, No. 3 attaches the lanyard to the cocking lever of the firing lock, walks to the rear through the passage between the rammer tray and the left side frame, uncoiling the lanyard as he goes, and takes post on the outer edge of the gun platform in rear of the breech. At the command FIRE, he fires the piece by a quick, strong pull (not a jerk) on the lanyard.

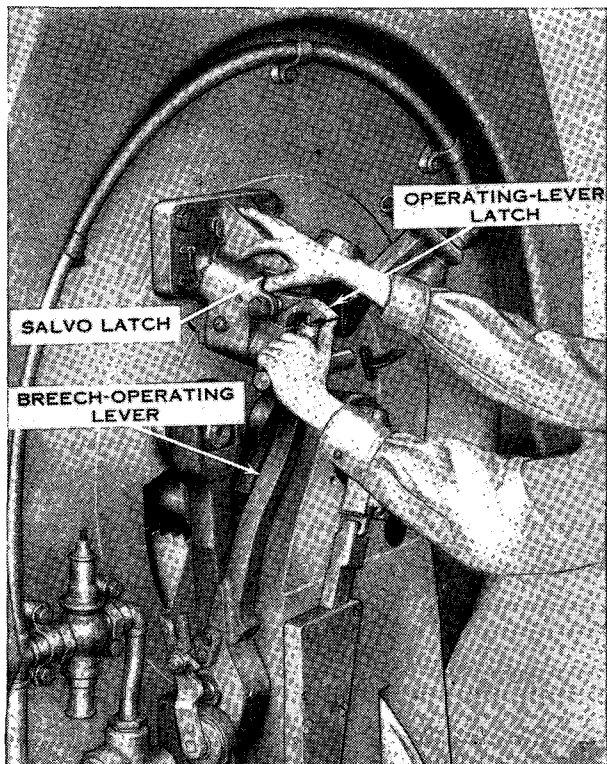

Figure 9. Unlatching the breech-operating lever.

e. No. 1 watches the firing lock, while No. 2 lowers the breech-operating lever, to see that the fired primer is completely ejected from the firing lock.

22. OPERATION OF BREECH. a. *To open the breech*, No. 2, with the thumb of one hand, presses the salvo latch inward to disengage the operating-lever latch. He grasps the breech-operating lever handle with the other hand, using his thumb to move the operating-lever latch upward to disengage the operating lever (fig. 9). He pulls the breech-operating lever downward, causing the breechblock to rotate, thus disengaging the threads of the breechblock from their seat in the gun breech. No. 1 grasps the breechblock handle and

GAS-EJECTOR VALVE

LOADING TROUGH

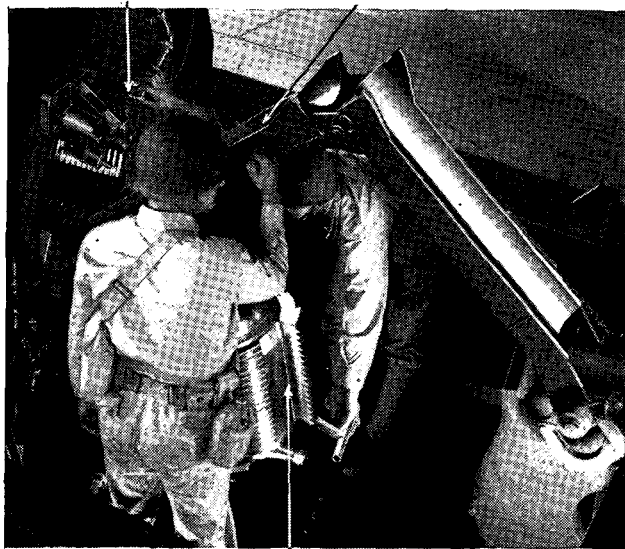

BREECHBLOCK

Figure 10. Opening the breechblock.

assists No. 2 in easing the breechblock to the open position. To latch the breechblock open (fig. 10), it may be necessary for No. 1 to exert a downward pressure on the breechblock after it has come to rest.

b. To close the breech by air pressure (fig. 11), No. 2 first kicks the tripping handle of the holding-down latch with his right foot and then pulls out the handle of the breech-closing valve. The air pressure, acting on the plunger rod of the closing mechanism, raises the breechblock into the breech recess. The cam rollers, attached to the breech-

GAS-EJECTOR VALVE

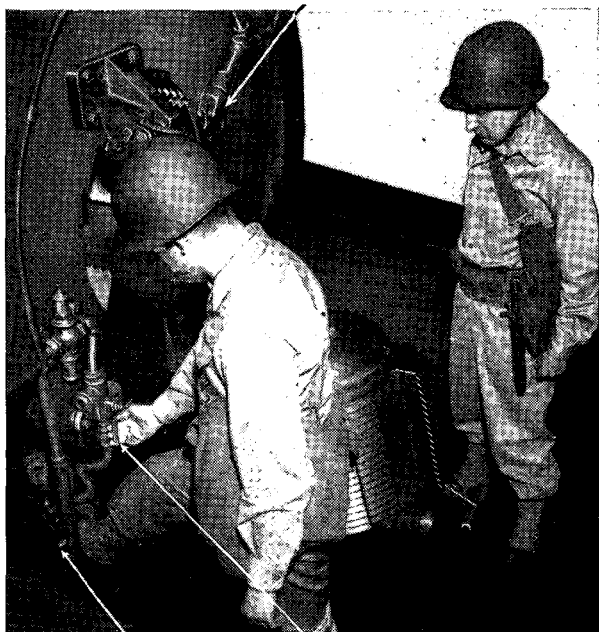

LATCH-TRIPPING
HANDLE

BREECH-CLOSING
VALVE

Figure 11. Closing the breechblock.

block, strike the rotating cam surfaces located on the upper and lower breech face. This gives the breechblock its initial rotation, guiding it into the threads to the point of engaging them in the breech recess. The movement of the breechblock in closing whips the breech-operating lever upward, rotating and closing the breech. No. 2 uses his right foot to release the holding-down latch, thus keeping his body clear of the breech-operating lever which may be driven upward with terrific force. If the breech-operating lever goes to the latched position, the shock of the blow is absorbed by the operating-lever buffer plunger housed in the lower part of the upper cam. No. 1 may assist the air pressure in closing the breech. He crosses the loading platform and with his right hand pushes in the breech-operating lever to insure that it is in the latched position. With the little finger of his left hand, No. 1 pulls the retracting-lever latch to the rear, moving the firing lock slide to the open position. He then moves off the loading platform to the left. The M1919MII and the M1919MIII guns are not equipped with a holding-down latch and in some cases the breech-closing valve is on the right side of the breechblock. Modify the service of the piece for these guns to allow for variations of materiel.

c. To close the breech by hand, No. 1 grasps the breechblock handle and No. 2 trips the holding-down latch. Both men raise the breechblock into the breech recess. As the breechblock nears the closed position, No. 2 grasps the breech-operating lever and continues through with the movement of the lever until it is latched and the breechblock rotated into the closed position.

23. LOADING. a. General. To load, set the gun at $3^{\circ} 48'$ elevation. There are a loading position pointer and a mark on the right elevating rack to facilitate setting the gun at this elevation. If the elevation of the gun is much above or below

this elevation, the loading trough will not seat properly in the breech recess. Allow the rammer motor to run at full speed before attempting to ram the projectile. Start the motor by pressing the START button located near the rear end of the right side frame.

b. Ramming the projectile. (1) To ram the projectile, No. 5 moves the rammer control lever (fig. 12) up to the RAM position. For safety reasons he should grip the handle loosely or, even

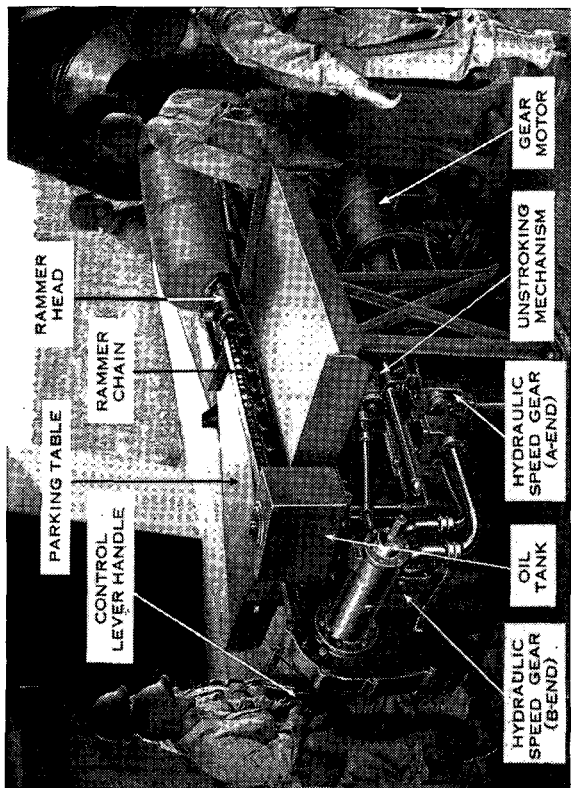

Figure 12. Operating the rammer.

better, rest his hand on top of the rammer control lever. As the projectile nears the seated position, the unstroking device moves the hydraulic speed gear control and the control lever toward neutral. No. 5 follows the rammer control lever down with his hand, shoving the handle the last short distance to the neutral position. The control lever will not move to neutral because the unstroking device is adjusted to bring the rammer head to a stop 10 inches beyond the point where the projectile is seated. Because of this, the control lever does not reach the neutral position and must be moved there by hand.

(2) On power rammers not equipped with an unstroking device, No. 5 sees that uniform ramming is obtained. Maximum speed should be attained at the moment of seating of the projectile and positive pressure should be maintained for about 1 second after the seating. At the same time, No. 5 uses care to prevent "buckling" or "jumping" of the rammer chain.

c. *To withdraw the rammer*, No. 5 moves the rammer control lever downward to the WITHDRAW position and removes his hand from the rammer control lever. The unstroking device will bring the rammer head to a stop at the rearmost position and move the rammer control lever to neutral. On power rammers not equipped with an unstroking device which operates on the withdraw stroke, No. 5 exercises care to see that the rammer head does not run into the stop when returning at high speed.

d. *To ram the powder*, No. 5, controlling the speed of the rammer, moves the control lever slowly upward towards the RAM position. When half the bags of the powder charge are in the loading trough, No. 5 moves them forward far enough so that the remainder of the powder bags may be placed in the loading trough. When the complete powder charge is in the loading trough he moves the powder charge forward slowly, but not

so far as to prevent the mushroom head of the breechblock from imparting the last forward motion to the powder charge when the breech is closed. This will require training and the use of appropriate marks on the rammer chain. No. 5 takes care to see that the powder bags are not torn or deformed during the ramming operation.

e. *In withdrawing the dummy projectile*, slow up the projectile with the hand extractor and bring it to rest without striking the rammer head. If the projectile is given a great rearward velocity and allowed to slide down the loading trough without being checked until it is suddenly stopped by the head of the rammer chain, serious damage to the rammer head, rammer case, and other rammer mechanisms may occur.

f. *When the rammer chain is run forward by power without a projectile or powder charge being rammed*, No. 5 exercises great care to see that the rammer chain is not moving at a great speed when the unstroking device stops it. Failure to do this may damage the rammer chain, unstroking device, hydraulic speed gear, or other parts of the rammer mechanism. Also, he does not allow the rammer head to reach the rifled section of the bore at a great speed because the rifling may be damaged.

g. *To ram the projectile by hand using the rammer*, No. 5 first pins the power clutch fork in the inner hole to disengage the rammer motor from the gearing. Next, the hand cranks are assembled to the crankshaft and the control lever placed in the neutral position. No. 5 then takes position on the left-hand crank with two other men and supervises the work of hand ramming. Three more men are needed on the other hand crank to obtain proper seating of the projectile. The speed of the cranks should be steadily increased so that maximum speed is obtained at the instant of seating of the projectile. Care should be taken to see

that no one is injured when the chain and cranks stop with a jerk at the instant the projectile is seated.

24. TRAVERSING MECHANISM. a. *To traverse the gun by power* (fig. 13), the gun pointer first sets the traversing shift lever to the **POWER** position, sees that the traversing control detent is at neutral (the zero mark on the indicator dial coincides with the index line on the gear case), and then starts the traversing motor. The gun may be traversed in either direction at a constant rate

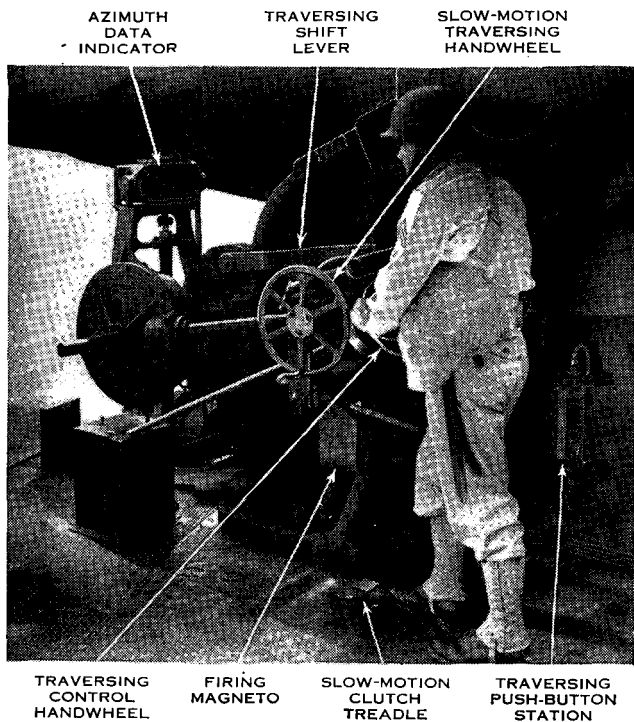

Figure 13. Traversing the gun.

by moving the traversing control handwheel in the desired direction. To stop the motion of the gun, the traversing control handwheel must be moved back to neutral. However, on the M5 carriage there is a new type of follow-up power drive similar to the elevating mechanism described in paragraph 25. Power control is obtained through the slow-motion (follow-up control) handwheel which must be continuously rotated to traverse the gun. The speed of rotation of the handwheel controls the speed of traverse, while stopping the handwheel stops the motion of the gun.

b. To traverse by hand, set the traversing shift lever to the HAND position. The traversing cranks, manned by four men (two on each crank), are used to swing the gun quickly from one target to another. The traversing slow-motion clutch treadle must be up to prevent the slow-motion handwheel from spinning rapidly. When tracking a target, use one set (either right side or left side of carriage) of the traversing slow-motion handwheels and see that the corresponding clutch treadle is down. Take care to prevent the carriage, when under full manual power, from coming into contact with the positive stop.

c. Traversing limit switch. The traversing limit switch is used to cut off the power to the traversing motor as the gun nears the limits of its traverse in either direction. When this switch has stopped the motor, the latter can be started by pushing both the LIMIT-SWITCH and START buttons, located at the traversing push-button station. The motor can be kept running by holding down the limit-switch button until the limit switch ceases to cut off the motor, that is, until the wheel on the limit-switch lever clears the stop rail on the base ring. However, before restarting the motor, the traversing control *must* be set at neutral. If it is necessary to traverse the gun by power beyond the point where the traversing limit switch cuts off the motor, move the gun very

slowly. Under such circumstances it is advisable to continue tracking by hand power, using the slow-motion handwheel.

25. ELEVATING MECHANISM. a. *To elevate by power* (fig. 14), the elevation setter first sees that the elevating clutch lever is in the POWER position and then presses the START button to activate the elevating motor. Turning the follow-up control handwheel counterclockwise will elevate the gun. As long as the handwheel is in motion the gun will move. To hold the gun at a certain elevation, the follow-up control handwheel need only be stopped.

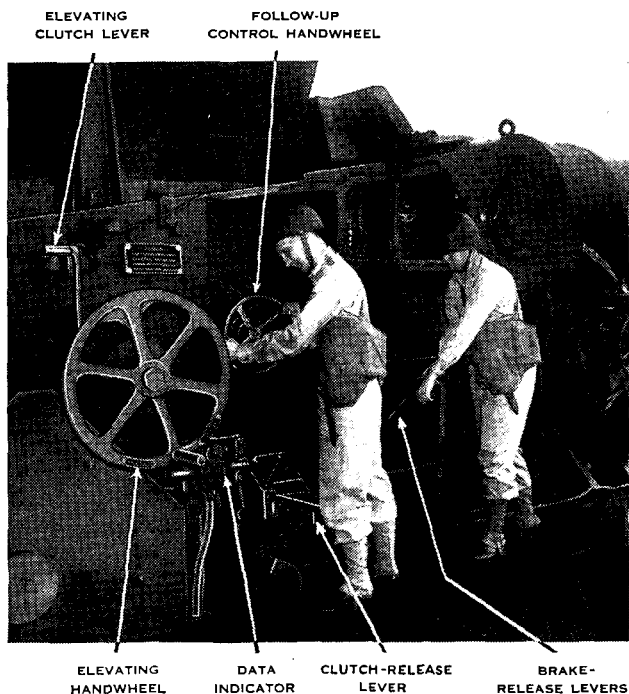

Figure 14. Elevating the gun.

b. As the gun nears either limit of elevation, one of the two control shaft stop clutches becomes engaged, thus making it impossible to continue to turn the follow-up control handwheel in the same direction. Operation of the handwheel in the opposite direction is possible. However, should it be necessary to facilitate easy release of the clutch for reverse movement, the operator throws the clutch out of engagement with the knee-operated clutch-release lever. When the clutch is disengaged, the gun may be elevated (or depressed) by electric power beyond the point of automatic action of the control shaft stop clutch. Therefore, when operating the power elevating mechanism at the extreme limits of elevation and depression, proceed with care. It is advisable to move the gun beyond these points by hand power.

c. To elevate manually, the elevation setter sets the elevating clutch lever to the HAND position. By turning the elevating handwheel in either direction he may elevate or depress the gun with the assistance of two men turning the crank on the left side of the carriage. The gun is balanced so that when it is loaded it is "breech heavy" and easy to elevate; after the gun has been fired and the chamber is empty, it is "muzzle heavy" and easy to depress.

d. The brake-release levers must always be raised and held in the raised position before any attempt is made to elevate or depress the gun by hand or motor power.

26. RECOIL PARTS LOCK. The recoil parts lock has been provided to prevent the gun from sliding out of battery when it is elevated and the air pressure in the recuperator cylinders is insufficient to keep it in battery. The recoil parts lock is at the right top just below the right recuperator cylinder at the joint of the recoil band and cradle (fig. 15). Before firing the gun or exercising the parts that move in recoil, the chief of breech, by

the direction of the gun commander, removes the recoil parts lock nut from the stud. Always replace this nut immediately after the firing of the gun or when the exercising of the parts that move in recoil is complete. Never remove the recoil parts lock nut until it has been ascertained that there is the required air and liquid pressure in the recuperator cylinders (par. 45).

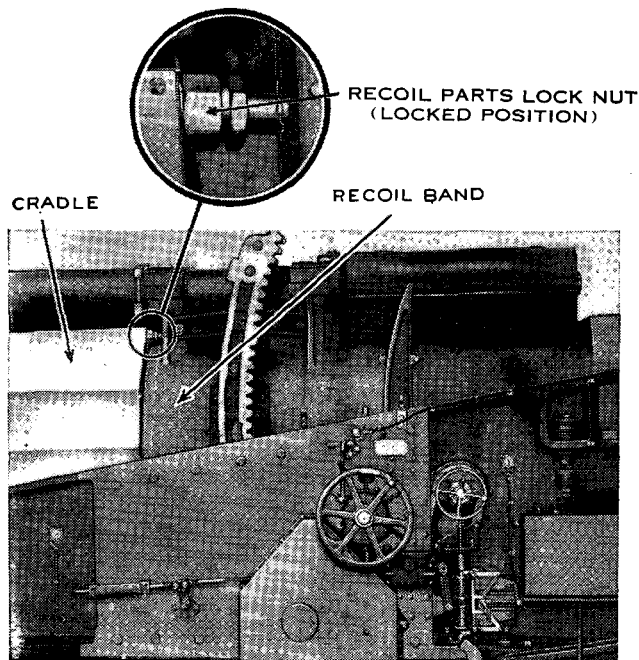

Figure 15. Recoil parts lock.

27. MOTORS. All the electric motors on the carriage are 3-phase, 60-cycle, 440-volt alternating current motors. Each motor is equipped with a push-button station and a controller. If for some reason the motor is overloaded, the controller will

break the circuit and stop the motor. Before starting the motor again, determine the reason for the overload and correct it. Then move the lever on the controller counterclockwise to the OFF and RESET positions and return it to the ON position, then push the START button at the push-button station.

28. AIR COMPRESSOR. a. Controller system.

The air compressor may be run either continuously or intermittently so that an air pressure of from 135 to 155 pounds per square inch is maintained. To put the compressor in intermittent or automatic operation, depress the button marked AUTOMATIC. When the air pressure in the air receivers reaches a pressure of 155 pounds per square inch, the automatic pressure switch and magnetic unloader operate to open the power circuit to the air compressor motor and stop it. When the pressure reaches 135 pounds per square inch the circuit is closed and the air compressor motor started. To set the air compressor for continuous operation, depress the button at the push-button station marked CONTINUOUS. The air compressor motor does not stop when the air pressure reaches 155 pounds per square inch but continues to run. In this case, the pumping action is stopped by the automatic pressure switch and magnetic unloader which causes the intake valves to be held open until the minimum allowable pressure (135 pounds) is reached; then the pumping action starts again.

b. Operation. (1) The artillery mechanic is responsible for the care and operation of the air compressor (fig. 16) and associated mechanisms. He must be thoroughly trained and schooled in the care and operation of the compressor. Before starting the air compressor he must—

(a) Check the level of the oil in the crankcase and fill it if necessary.

(b) Close the interstage cooler drain cock.

(c) Open the interstage cooler vent cock.

(d) Rotate one turn the oil filter agitator (not shown in fig. 16) located at the lower left rear of the interstage cooler.

(2) The air compressor motor may now be started by pressing the START button at the air compressor push-button station. Determine whether the compressor is to operate continuously or automatically as follows:

(a) If details have been posted, then the compressor will be operated continuously and the CONTINUOUS push button is pressed.

(b) If the gun is to be held in readiness for action, then the AUTOMATIC push button is pressed.

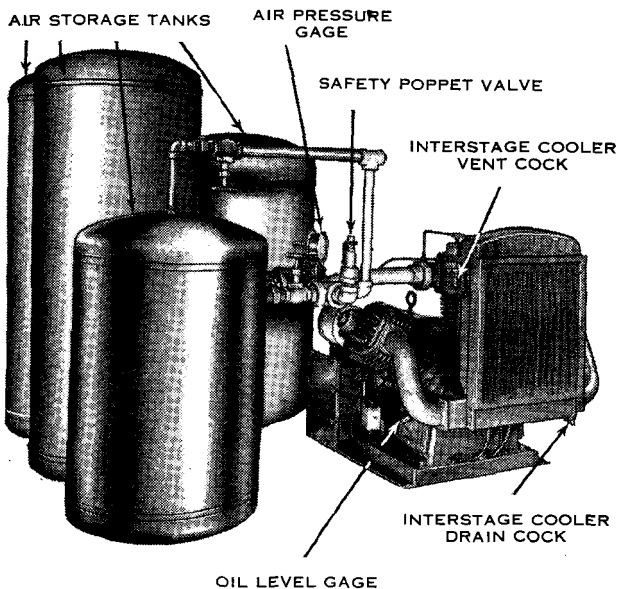

Figure 16. Air compressor.

(3) If the operation is to be automatic, open the interstage cooler vent cock. It may be closed when the compressor is operating continuously. After 10 minutes of operation, examine the air gauge to see that the air pressure is between 135 and 155 pounds per square inch and note the oil pressure gauge to see that the oil pressure is between 30 and 35 pounds per square inch.

(4) When the air compressor is shut down, leave the interstage cooler drain cock open to drain the condensation from the interstage cooler. Also, leave the interstage cooler vent cock open.

29. FIRING THE PIECE. a. If a gun commander's push-button station is provided, the gun commander fires the gun (par. 10) on signal or call of "Set" from the elevation setter, the gun pointer having unplugged his firing key. He stands clear of the push-button station, particularly after the primer is inserted and before No. 3 is off the breech operating platform.

b. In case the gun is not equipped with a gun commander's push button, the brake operator (No. 4) fires from the right side of the carriage on the command FIRE given by the gun commander. The brake operator uses the magneto located near his position.

c. If case II firing is being used and there is a firing key or magneto at the slow-motion hand-wheel, the gun pointer fires the gun when he is on target after the gun commander calls, "Ready."

d. If in an emergency it is necessary to use the lanyard, No. 3 or a man designated by the chief of section will fire the piece in accordance with conditions prevailing at the time.

SECTION V

SAFETY PRECAUTIONS

30. GENERAL. a. The following safety precautions are prescribed for peacetime conditions. They also indicate the principles to be followed under war conditions, but should be interpreted according to the circumstances existing at the time of any particular emergency.

b. Further instructions concerning safety precautions to be followed will be found in AR 750-10 and FM 4-20.

31. THE COMMAND CEASE FIRING. Any individual in the military service will command or signal: **CEASE FIRING** if he observes any condition which makes it unsafe to fire. At the command **CEASE FIRING**, the gun commander stands clear of the gun commander's push-button station and keeps all other personnel away. If one of the firing magnetos at the slow-motion traversing handwheels is being used, the person responsible for firing the gun keeps his hands and all personnel away from the firing magneto. If the lanyard is attached, the gun commander causes it to be detached.

32. PRIMERS. Precautions in the care and handling of primers will be observed as follows:

a. Before firing, examine the primer pouch to make certain that it contains live primers only. Prior to firing, test all primers for fit in the firing mechanism and primer seat, and examine the primer seat for foreign particles which would

interfere with the seating of the primer. Also, test each primer electrically, on the electric primer tester, for resistance and continuity of circuit.

b. Take care not to drop primers.

c. Except when testing safety devices, do not insert primers until after the breechblock has been closed and locked.

d. Discard fired primers as soon as they are removed from the firing lock.

e. Handle with care and do not attempt to use primers that have misfired. Return these primers to ordnance for inspection.

33. POWDER CHARGE. Do not bring the powder charge for any given round near the breech until the preceding round has been fired, the powder chamber blown out with compressed air, the face of the mushroom head wiped, and the bore announced clear. All powder charges in the magazine must be kept in their containers except the charge which is to be served to the piece for the next succeeding round. (See FM 4-20.)

34. POWDER CHAMBER. After firing, the gases are automatically blown out of the chamber and bore by compressed air when the breechblock is opened. No. 1 inspects the bore and chamber before reloading to see that the chamber is clear of smoldering fragments; by day he must be able to see light through the bore, and at night that the entire bore is clear of flame and luminous gas. He then announces, "Bore clear," and closes the gas-ejector valve. In case of failure of the air supply, sponge the chamber after each shot with the liquid provided (par. 50).

35. POOR VISIBILITY. During target practice, stop firing at once if visibility becomes so poor as to endanger the target-towing vessel and shipping in the field of fire.

36. MISFIRES. A misfire occurs if the piece fails to fire when desired. Make two attempts to fire the primer before it is removed. If upon examination it is found that the primer is not fired, insert a new primer and continue fire. If the primer has fired, allow a minimum of 30 seconds before opening the breech and removing the faulty charge. Store the faulty charge separately from other charges.

SECTION VI

CARE AND ADJUSTMENT OF MATERIEL

37. GENERAL. a. Officers will be held strictly responsible for the proper care and preservation of all artillery materiel in their charge.

b. All officers and others having materiel in their charge should be thoroughly acquainted with the methods prescribed in this manual and other War Department publications for the operation, care, and preservation of materiel.

c. Use cleaning and preserving materials in strict compliance with ordnance regulations.

d. Undertake such repairs as may be handled by the battery personnel only under the supervision of an officer or the artillery mechanic. In all cases where the nature of the repair or adjustment is beyond the scope of the enlisted personnel, ordnance will provide, upon request, trained personnel for the work.

e. Dirt and grit accumulated through exposure to the weather or from the blast of the piece in firing settle on the bearing surfaces and, in combination with the lubricant itself, form a cutting compound. Powder fouling attracts moisture and hastens the formation of rust. Therefore, the gun and carriage must be cleaned at frequent intervals, especially before and after firing. The procedure in cleaning is described in detail in the following paragraphs and in TM 9-471. The following cleaning materials are issued by the Ordnance Department for use in the field.

(1) *Burlap* which is used over the sponge for cleaning the bore.

(2) *Crocus cloth* for removing rust or stains and for polishing the breech mechanism, the firing mechanism, and other finished metal surfaces.

(3) *Abrasive aluminum-oxide cloth* for cleaning unfinished or nonbearing steel surfaces only. Do not use this material on the surfaces of the breech and firing mechanism.

(4) *Cotton wiping cloth* for cleaning all parts of the materiel except the gun bore.

(5) *Lens tissue paper* for cleaning lenses of optical instruments. Take special care to keep the paper free from grit, dirt, or dust which might scratch the glass surface. Before using this paper remove with a soft brush the dirt from optical surfaces. Then moisten the surfaces with breath and clean with the paper. Avoid hard rubbing.

(6) *Castile soap* for preparing the sponging solution described in paragraph 50.

(7) *Soda ash* for cleaning the bore as described in paragraph 51.

(8) *Dry-cleaning solvent*. Unless otherwise specified, use dry-cleaning solvent or Diesel fuel oil to clean or wash all metal parts whenever partial or total disassembly is undertaken or when renewing the protective lubricant film on exposed metal surfaces. Dry all parts thoroughly before lubricating.

(9) *Natural or cellulose sponge* which is used with water and very mild cleaning solutions for washing and rinsing.

(10) *Cotton waste* for general cleaning purposes where lint will not interfere with the operating mechanisms of the weapon. Colored cotton waste may be used on the exterior parts of the equipment. Use white waste for cleaning all finished surfaces.

38. FIRING LOCK. a. The parts of the firing lock are very closely adjusted and the clearances are very small. Exercise great care, therefore, in keeping the mechanism well oiled and free from

rust and dirt. Remove it from the gun when not in use, keep it in the small box provided, and store it in the armament chest.

b. Examine all parts of the firing lock (fig. 17), looking especially for a—

- (1) Broken extractor.
- (2) Worn extractor cam.
- (3) Deformed firing pin.
- (4) Broken or weakened firing spring.

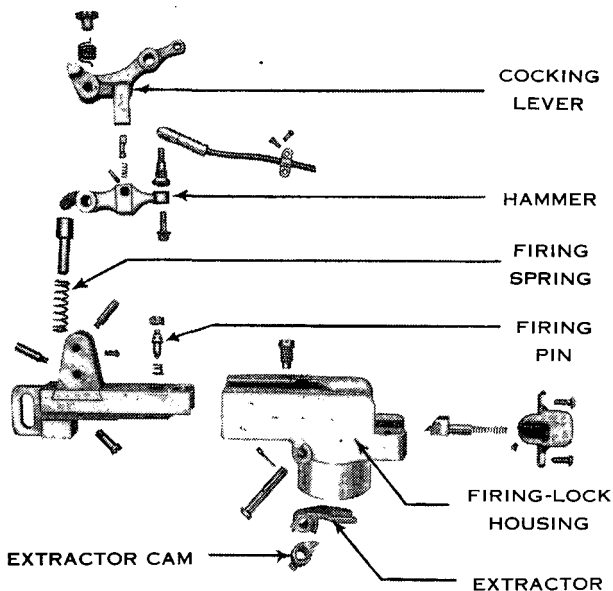

Figure 17. Firing lock.

c. Fouling of the firing pin and the use of thicker oil than authorized will cause the mechanism to absorb the blow of the firing lock hammer and result in misfires.

d. The combination percussion-electric primer is used with the firing lock.

e. The slightest withdrawal of the slide from the closed position should remove the firing pin from the percussion cap of the primer and preclude firing either electrically or by percussion.

f. To insure proper functioning, always use a firing lock which has been tried and is known to function satisfactorily on a particular gun.

39. OBTURATOR. a. Wash or brush the primer seat and vent hole in the obturator spindle (fig. 18) to remove every trace of powder fouling or gummy oil, then wipe dry and oil. In cleaning, use the reamer, brush, and vent cleaning tools provided for this purpose. The slightest accumulation of fouling in the primer seat will cause the primer to enter with difficulty; likewise, difficulty will be experienced in extracting the primer, with the possibility of breakage of parts.

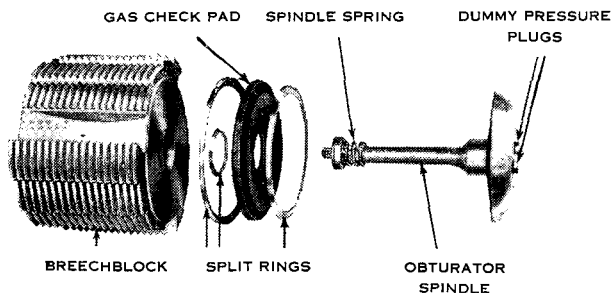

Figure 18. Breechblock and obturator.

b. The mushroom head, obturator spindle, and split rings require continual care to prevent rusting and pitting. Inclose the gas check pad, when removed from the gun, in the container provided to preserve it from deformation or contact with moisture. To prevent possible injury to the pad, always open the gas check pad container with the ordnance tool provided. To clean the gas check

pad, remove it from the obturator spindle, wipe it clean with a dry cloth, and then oil *lightly* with a clean cloth dampened with engine oil (SAE 30 above $+32^{\circ}$ F., or SAE 10 below $+32^{\circ}$ F.).

40. BREECH AIR PRESSURE. To adjust the breech-closing air pressure, adjust the reducing valve (fig. 6) on the breech to an operating pressure just sufficient to close and lock the breech-block. This pressure varies according to the temperature, closing cylinder springs, and condition of the breech mechanisms. Too high a pressure unnecessarily slams the mechanism into the breech recess.

41. AIR COMPRESSOR. When the air compressor is run on CONTINUOUS operation (par. 28) for several hours, oil consumption may be high with the resulting danger of insufficient lubrication. Maintain a normal oil level at all times. Check the oil each day and just previous to starting the air compressor. Check all automatic control mechanisms often to insure that they are all in proper operation. Also, test the pressure relief valves to see that they function at the proper pressure. Instruct personnel in the operation of the individual air compressor. The ordnance officer or the existing manuals may give assistance in this instruction.

42. ELEVATING BRAKE. a. An elevating brake (fig. 19), consisting of a brake drum and brake band, is located on each side frame of the gun carriage. Each brake is always set when the brake levers are down, and they must be released by lifting the brake-release lever before power is applied to the elevating mechanism. The brakes stop the gun at any angle of elevation, when the brake-release levers are down, and prevent rotation of the tipping parts during recoil.

b. In the care and adjustment of the brakes proceed as follows:

(1) Inspect and test the braking mechanism at frequent intervals to insure that there is no binding or drag on the brake drums when the brake levers are raised, and that the brake drums and bands are in proper contact when the brake-release levers are down.

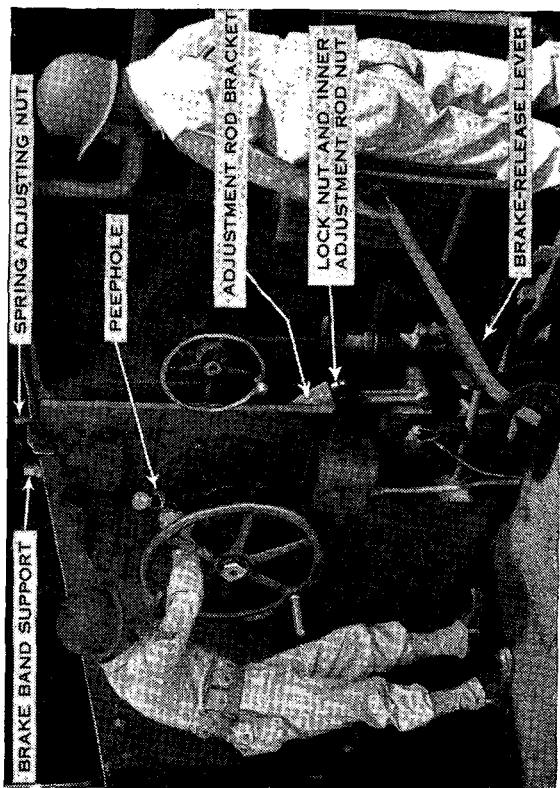

Figure 19. Checking the elevating brake clearance.

(2) The clearance between the top of the brake drum and the brake band should be $1/32$ inch when the brakes are released. A peephole is provided on each side frame through which this clearance can be checked. To adjust the clearance, remove the cap from the adjusting screw on top of the frame just above the brake (fig. 19), slip out the cotter pin, and turn the spring adjusting nut until the proper clearance is obtained.

(3) Take up the wear on the brake band by loosening the lock nut on the brake band adjustment rod and tightening the inner adjustment rod nut, being sure not to tighten it too much and cause the brake band to drag on the brake drum when the brakes are released. When the adjustments are made, replace and tighten all nuts, caps, and cotter pins.

43. ANTIFRICTION DEVICE. a. The antifric-tion device (fig. 20) on the M1919, M1919M1, M2, M3, and M4 carriages is designed to reduce the effort required to elevate or depress the gun and to take the shock of recoil without damage to the mechanism. The weight of the tipping parts of the gun is supported by roller bearings except at the time when the gun is fired. At that time, the force of the gun in recoil compresses the Belleville springs of the mechanism, and the trunnions of the cradle seat themselves on the main trunnion bearings of the side frames. After the effect of the recoil has been absorbed, the antifric-tion mechanism returns the cradle to its original position where it again floats on the roller bearings.

b. Before any attempt is made to elevate or depress the gun, check the cradle trunnion clearance of the antifric-tion device on each trunnion by means of the special thickness gauges provided, and make any necessary adjustment to insure that the trunnions are properly floated in their support. The clearance at the bottom of the trunnions should be no more or less than 0.008 of an inch.

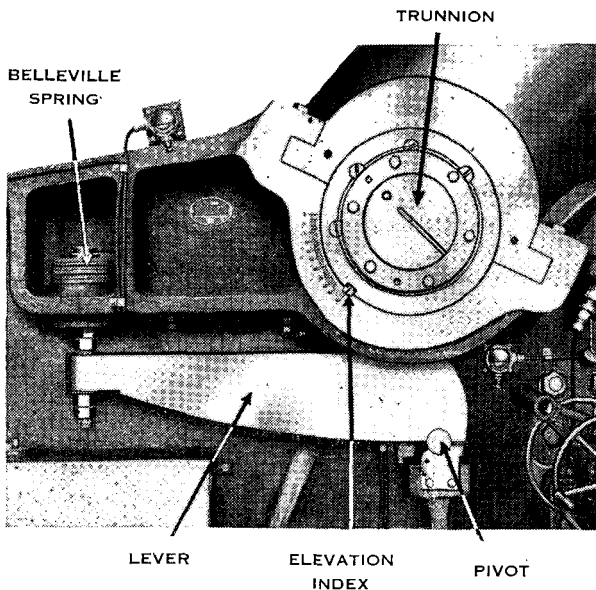

Figure 20. Antifriction device.

No reliance should be placed on the fact that this operation was performed a short time before. A slight sagging of the spring of the antifriction device would affect, and might nullify, any previous setting. Check the clearance from the inside of the side frame, that is, between the side frame and the cradle. Make adjustments at the lower adjusting nuts, located under and above the rear end of the antifriction levers, by turning the nuts until the proper clearance is obtained.

c. The M5 carriage is not equipped with the antifriction device but has special bearings on which the tipping parts rest at all times during the elevating or depressing of the gun and during firing.

44. RECOIL MECHANISM. a. General. The recoil mechanism of the M1919 carriage consists of four cylinders; one short and one long, located at the top of the cradle; and one short and one long, located at the bottom of the cradle. The recoil mechanism of the M1919M1, M2, M3, M4, and M5 carriages consists of one recoil cylinder located at the center bottom of the cradle. The glycerin-water mixture described in paragraph 46 is used in all recoil cylinders.

b. To check and fill the recoil cylinders, M1919 carriage. The M1919 carriage has four recoil cylinders, two on each side. To check the liquid in the recoil cylinders, loosen the filling plug below the expansion tank. If liquid oozes out, the recoil cylinders are filled. On the other hand, if there is no flow of liquid when the filling plug is removed, fill the cylinders as follows:

(1) Set the gun at 0° elevation.

(2) Remove the cap from the filling connection directly under the expansion tank and attach the filling funnel.

(3) Remove the vent plugs from the top of the rear end of the upper and lower recoil cylinders.

(4) Slowly pour the recoil liquid into the funnel until it runs out of the vents in the top of the rear end of each cylinder.

(5) Close the vents with the vent plugs and replace the cap on the filling connection.

(6) Change the filling funnel to the other side of the carriage and fill the two remaining recoil cylinders. The capacity of each long recoil cylinder is 35 gallons and of each short recoil cylinder 17 gallons.

c. To check and fill the recoil cylinder on the M1919M1, M2, M3, M4, and M5 carriages. To check the liquid in the recoil cylinder of the M1919-M1, M2, M3, M4, or M5 carriages (fig. 21), remove the plug cap from the tee in the expansion

chamber pipe. If there is no flow of liquid from the tee, proceed to fill the recoil cylinder as follows:

- (1) Set the gun at 2° elevation.
- (2) Support the funnel end of the filling device on the bracket on the right side of the cradle.
- (3) Remove the filling valve cap and attach the filling device to the valve body.

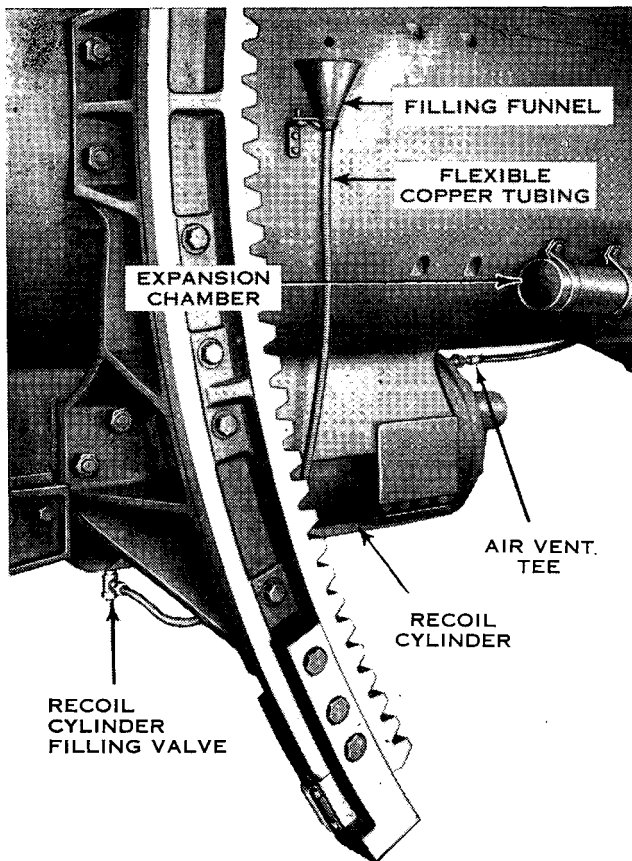

Figure 21. Recoil cylinder filling device.

(4) Unscrew the valve plug about nine turns, or approximately $\frac{3}{4}$ inch.

(5) Remove the plug cap from the tee under the expansion tank to allow the air to escape from the recoil cylinder.

(6) Pour the liquid into the funnel of the filling device until the liquid flows out of the tee. (The capacity of the recoil cylinder is 73 gallons.)

(7) Close the valve plug and replace the plug cap.

(8) Remove the filling device and replace the filling valve cap.

45. RECUPERATOR SYSTEM. a. General.

(1) The recuperator system is hydropneumatic. On the M1919 carriage it consists of two recuperator cylinders, one at the top and one at the bottom of the cradle. On the M1919M1, M2, M3, M4, and M5 carriages it consists of three recuperator cylinders (fig. 2), all at the top of the cradle. A floating piston separates the liquid from the gas in each cylinder. The action of the compressed air provides the energy to bring the gun back into battery while the liquid provides a suitable means of sealing the cylinder. The liquid used in the recuperator system is the mixture of glycerin and water described in paragraph 46.

(2) Keep the amount of liquid in the recuperator cylinders within definite limits at all times. Visual indication of the amount of liquid in the recuperator cylinders is given by position of the washer (fig. 22) on the piston rod which protrudes from the front of each recuperator cylinder. Never allow the washer to reach points closer than $\frac{1}{2}$ inch ($\frac{3}{8}$ inch on the M1919 carriage) nor more than 5 inches from the piston rod outer gland. On the M1919M1, M2, M3, M4, and M5 carriages an indicator graduated in inches from 0 to 5 defines these limits. Whenever the recuperator system is being initially filled or the air pressure adjusted, care must be taken to see that the piston rod nut

washer is kept near a $1\frac{1}{2}$ reading on the liquid indicator. This necessitates, first, the adjusting of the liquid volume, then making the necessary air pressure adjustment and continually checking the position of the piston rod nut washer.

(3) Maintain a normal air pressure of 1,700 pounds per square inch in the recuperator cylinders. With this air pressure in the cylinders and the proper amount of liquid (see (2) preceding), the liquid pressure should be 1,842 pounds per

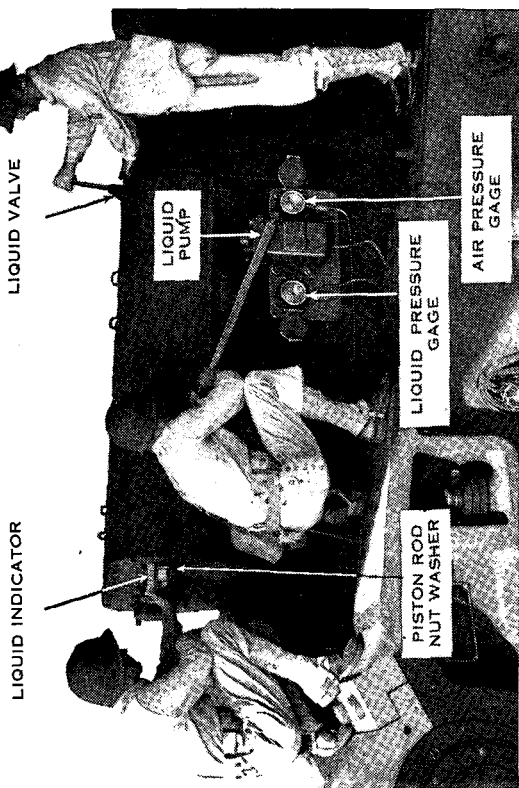

Figure 22. Filling the recuperator cylinders with liquid.

square inch (1,950 pounds per square inch for the M1919 carriage). This provides a check which indicates whether the piston is floating properly. Report any great variation from this pressure to the ordnance officer.

b. To adjust the liquid volume. (1) *To replenish the recuperator cylinders* with liquid (the piston rod nut washer will be some distance above the $1\frac{1}{2}$ mark on the liquid indicator); use the liquid pump (fig. 22) which is on the left side of the cradle to the rear.

(a) Remove the filling cap in the top of the pump and insert the funnel provided.

(b) Fill the pump with the same liquid (par. 46) as used in the recoil cylinder.

(c) Replace the filling cap on the pump and check to see that the gravity filling valve and gravity filling inlet cap on each cylinder are closed.

(d) Open slowly the pressure filling valve on *one* recuperator cylinder about six turns (approximately $\frac{3}{4}$ inch).

(e) Apply pressure by operating the lever of the liquid pump, forcing liquid into the recuperator cylinder until the piston rod nut washer is near the $1\frac{1}{2}$ mark on the liquid indicator (see a (2) preceding).

(f) Close the pressure filling valve.

(g) Repeat this operation on each cylinder with the valves on the remaining two cylinders closed.

(h) The liquid pressure, as measured by the gauge to the left of the liquid pump, should stay within the limits prescribed in a (3) preceding.

(2) *To remove liquid from the recuperator cylinders* (the piston rod nut washer will be near the zero mark) proceed as follows:

(a) Check to see that the pressure and gravity filling valves on each cylinder are closed tightly.

(b) Remove the gravity filling cap on one of the recuperator cylinders.

(c) Open slowly the pressure filling valve and allow the liquid to trickle out.

(d) Close the pressure filling valve when the piston rod nut washer is near the $1\frac{1}{2}$ mark on the liquid indicator.

(e) Repeat when necessary for the other cylinders.

(f) Check the liquid pressure in each cylinder (see (4) following).

(3) *Initial filling of the recuperator cylinders* with liquid will be done before any air pressure is applied to the recuperator cylinder. To fill with liquid, proceed as follows:

(a) Set the elevation of the gun to -2° .

(b) Set the piston rod so that the index mark on the piston rod nut washer coincides with the $1\frac{1}{2}$ mark on the liquid indicator.

(c) Remove the dust guards that house the recuperator mechanism.

(d) Remove the gravity filling inlet cap and attach the special filling device (carried in armament chest).

(e) Open the gravity filling valve about seven turns (approximately $\frac{1}{2}$ inch).

(f) Pour the liquid slowly into the funnel allowing the air to escape from the cylinder. Fill the cylinder.

(g) Allow sufficient time for all air to escape from the cylinder; then remove the funnel, close the gravity filling valve, and replace the gravity filling inlet cap.

(h) Repeat the above process for each cylinder.

(i) Fill the recuperator cylinders with air as described in c following.

(j) Check the liquid pressure and the position of the index on the piston rod nut washer as to the zero mark (see a (2) preceding) on the liquid indicator—if not correct, adjust as in b (1) and b (2) preceding.

(4) *To check the liquid pressure* of each cylinder, proceed as follows:

(a) Make sure that all gravity filling valves are closed and that all gravity inlet caps are tight.

(b) Open the pressure filling valve on *one* recuperator cylinder slowly about six turns (approximately $\frac{3}{4}$ inch).

(c) Read the liquid pressure on the liquid pressure gauge, located on the left of the liquid pump (fig. 22). For the M1919 carriage the liquid pressure should be 1,950 pounds per square inch; for the M1919M1, M2, M3, M4, and M5, it should be 1,842 pounds per square inch.

(d) Close the pressure filling valve.

(e) Repeat the process for the other recuperator cylinders.

c. To adjust the air pressure. (1) *To check the air pressure*, proceed as follows:

(a) See that the maneuvering valve (fig. 23) is closed and the air inlet plug is in place unless the air filling device is attached.

(b) Open slowly the air manifold valve (fig. 24) about seven turns (approximately $\frac{1}{2}$ inch).

(c) Read the air pressure in the air pressure gauge, located to the right of the liquid pump (fig. 22).

(d) If the air pressure is not 1,700 pounds per square inch, adjust it (see (2) and (3) following) to this value.

(e) Close the air manifold valve.

(2) *To replenish the air pressure*, proceed as follows:

(a) Remove the air inlet plug from the maneuvering valve on the cradle near the left trunnion.

(b) Attach the air filling device, a length of tubing connected between the portable compressed air cylinder and the maneuvering valve.

(c) Open the valve stem in the maneuvering valve body.

(d) Open slowly the air manifold valve about seven turns (approximately $\frac{1}{2}$ inch).

(e) Open slowly the valve in the portable compressed air cylinder allowing the air to pass into the recuperator cylinders slowly.

(f) Observe the reading on the air pressure gauge; close the valve on the portable air cylinder when the pressure reaches 1,700 pounds per square inch. Should the air cease to flow before the required pressure is reached, it indicates that the pressure in the recuperator cylinder is the same as the pressure in the portable compressed air cylinder. In this case, it will be necessary to close the air maneuvering valve and the valve on

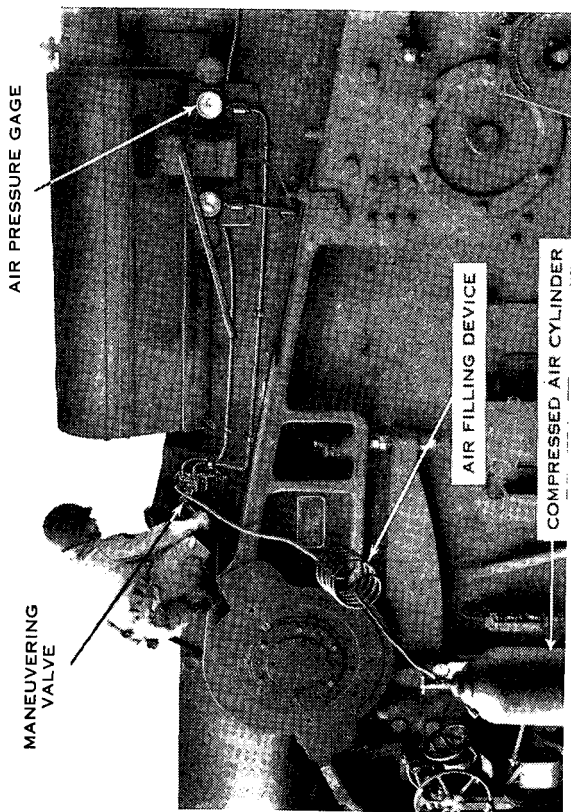

Figure 23. Filling the recuperator cylinders with air.

the compressed air cylinder and replace the latter with a full cylinder. Continue above operation until the air pressure gauge shows the required pressure.

(g) Close *all* valves, remove the portable compressed air cylinder and air filling device, and replace the air inlet plug in the maneuvering valve body.

(3) *To reduce the air pressure* when it is over 1,700 pounds per square inch, proceed as follows:

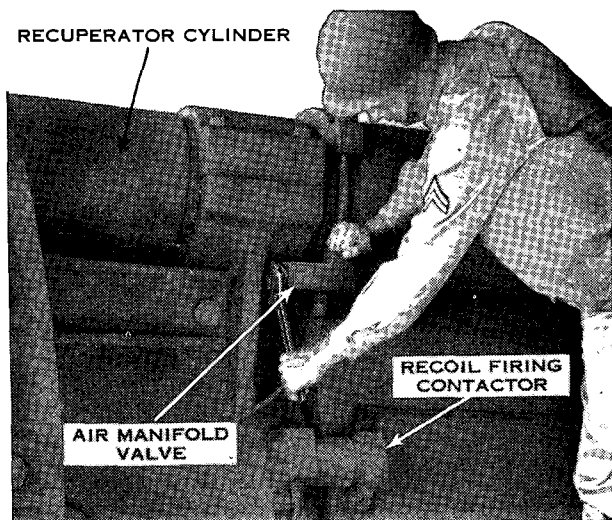

Figure 24. Operating the recuperator air manifold valve.

(a) Remove the air inlet plug from the maneuvering valve body.

(b) Open the air manifold valve about seven turns (approximately $\frac{1}{2}$ inch).

(c) Open the maneuvering valve and allow the air to escape slowly.

(d) When the required pressure is reached, close *all* valves and replace the air inlet plug.

46. RECOIL AND RECUPERATOR LIQUID. a. The glycerin-water mixture used in the recoil and recuperator cylinders will conform to the following:

Glycerin, grade A, USP, 60 parts by volume.
Distilled water, 40 parts by volume.

To each 3 gallons of the mixture add 1 ounce of sodium hydroxide, CP (NaOH) sticks or pellets (1 pound of sodium hydroxide to 48 gallons of mixture). Caustic soda (lye) *must not* be used.

b. Recoil mechanisms using 60 percent glycerin and 40 percent water will, in general, operate satisfactorily at subzero temperatures. Below 0° F., counterrecoil may become abnormally slow. Careful cleaning of recoil slides and application of prescribed low temperature lubricant will usually correct this condition. Although raising or lowering the glycerin content will vary antifreeze protection, it will also change considerably the specific gravity and viscosity. Therefore, the changing of the formula must not be attempted for this or any other reason.

c. Excess of sodium hydroxide will cause disintegration of the packing and corrosion of the bronze surfaces.

d. The glycerin-water recoil liquid should be replaced with fresh liquid whenever it is found necessary to drain cylinders. In cases of emergency the old liquid may be strained through a clean piece of linen or muslin and used for refilling the recoil mechanism.

47. CARRIAGE. a. Traverse the carriage and elevate and depress the gun throughout their entire allowed movement at least twice a month. From time to time change the azimuth at which the carriage stands to prevent uneven settling of the platform.

b. Keep all parts of the carriage free from rust at all times. If rust is found, remove it immedi-

ately. Its removal from all bearing parts, especially piston rods, requires particular attention in order that clearances will not be unduly increased. The use of emery cloth for this purpose by battery personnel is forbidden. Use nothing more abrasive than crocus cloth.

c. When the carriage is kept in readiness for service, keep all bearing surfaces and unpainted surfaces thoroughly cleaned and lubricated. Consult lubrication instructions (TM 9-471) and War Department Lubrication Orders as to frequency of lubrication, type of lubricant, and exact points for lubrication. The artillery mechanic is responsible for the lubrication and must see that the lubrication order is rigidly adhered to. If the gun is put to unduly heavy service, lubrication should be performed more often than is called for in the lubrication order.

d. Preserve with synthetic rust-preventive primer, followed by application of lusterless synthetic enamel (olive-drab), all parts of the gun and carriage which are authorized to be painted. This assists in the prevention of rust.

48. POWER RAMMER. a. Keep the power rammer well oiled and free from dirt, the rammer head cylinder filled with liquid at all times, and the stuffing boxes of the rammer head packed to prevent leakage. Report evidence of leakage to ordnance for correction.

b. *To oil the rammer chain*, open the breechblock and lower the loading trough. Run the rammer chain out on the loading trough until the rammer head comes to the rear end of the gun. With a small oil can, squirt oil on the inside of the chain rollers between the roller and the link, at the same time revolving each roller by hand to work the oil around the roller and its pin. Oil all the rollers that can be reached in this position of the chain. Move the chain ahead and oil the links and rollers as far back as they can be reached. Re-

peat this operation until all the rollers have been oiled.

c. To fill the rammer head cylinder, remove the rammer head cylinder cover on top of the rammer head and the filling plug from the expansion box. Fill the cylinder to overflowing with the glycerin and water mixture described in paragraph 46. Replace the filling plug and cover.

d. To adjust the unstroking device. (1) To adjust the unstroking device, first check the withdrawal cut-off point to see that it automatically stops the rammer just before the rammer head contacts the stop pins. To do this, run the rammer, under power, part way forward onto the loading trough and then, controlling the speed, slowly withdraw it until the unstroking device stops the rearward movement. If adjustment is necessary, loosen the setscrew (fig. 25) on the

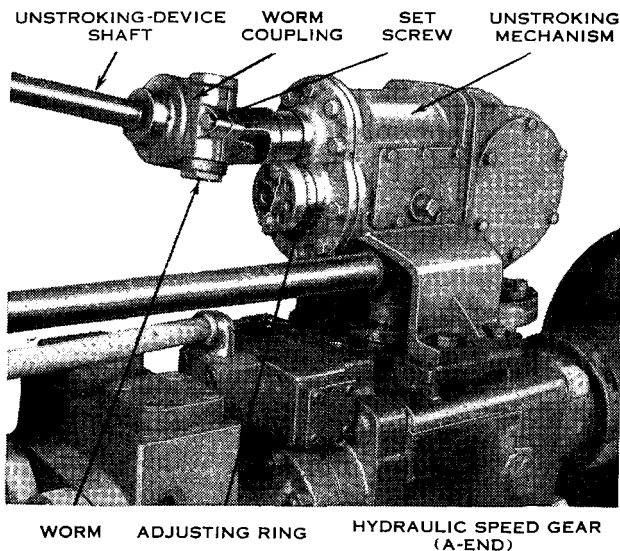

Figure 25. Unstroking mechanism.

worm coupling in the unstroking-device shaft near the unstroking mechanism, and rotate the worm in the proper direction until the correct setting is obtained. It will be necessary to move the rammer head forward, under power, and then withdraw it to determine if the correct setting has been made. It should be remembered that any adjustment of the cut-off point on withdrawal varies the ram cut-off point by the same amount.

(2) Adjustment of the ram cut-off point is made through the adjusting ring (fig. 25) on the rear end of the unstroking mechanism beneath the worm coupling. First, ram a dummy projectile into the chamber of the gun, seeing that it is properly seated. Next, move the rammer head into the chamber until it rests against the base of the projectile. At some convenient point make marks on the rammer chain and rammer trough that coincide. Remove the dummy projectile and make a mark on the rammer loading trough 10 inches forward of the first mark. With power, *slowly* move the rammer head into the gun until the unstroking device stops the forward movement. If the mark on the chain does not come within an inch of the second mark made on the loading trough, the unstroking device must be adjusted as follows:

(a) Remove the locking wire and the two bolts holding the adjusting ring.

(b) Turn the adjusting ring to the proper setting and replace the bolts in their holes. A scale on the adjusting ring is provided to assist in the setting. When the adjusting ring is rotated to the next hole, it moves the ram cut-off point about 1 inch. Adjustment of the ram cut-off point will not affect the withdrawal cut-off point; however, both it and the ram cut-off point should be checked after any adjustment is made.

49. HYDRAULIC SPEED GEAR. To replenish the elevating, traversing, or rammer speed gear,

use the special oil issued by the Ordnance Department for hydraulic speed gears. No other oil is authorized. Remove the cover of the expansion tank to be filled and pour oil slowly into it until the tank is one-half full. Operate the speed gear for a period of 5 minutes to allow air to escape from the oil. Stop the mechanism and add more oil, if needed, to bring it up to the half-full level in the expansion tank. Replace the expansion tank cover.

50. SPONGING SOLUTION. a. The sponging solution is a solution of water and castile soap. Its purpose is to provide a sponging liquid which will extinguish burning residue in the chamber of the gun and lubricate the breech recess. If the soap solution is not available, use plain water.

b. The solution is prepared by dissolving 1 pound of castile soap in each 4 gallons of water. Do not use yellow soaps as they are likely to leave a gummy deposit in the breech recess. Stir the water with as little agitation as possible to prevent foaming.

c. To avoid the necessity of handling large receptacles, as much soap as will be required may be dissolved in one bucket of water. This concentrated soap solution can then be added to water in other receptacles in the prescribed proportions.

51. CARE OF BORE. a. As soon as possible after any period of firing, and every day thereafter until all "sweating" has stopped, clean, dry, and oil the bore of the gun. The cleaning solution is made by dissolving $\frac{1}{2}$ pound of soda ash or 1 pound of sal soda in each gallon of boiling water. Wash the bore with this solution using a bore sponge wrapped with burlap. Then wash the bore with clear water to remove all solution. Wipe the bore thoroughly dry with new burlap. Finally, if

the piece is not to be used for a considerable time, coat the bore with medium or heavy rust-preventive compound, depending on local conditions. If the battery is on the alert apply a light coat of oil. Exercise care to prevent entry of the soda ash solution to parts of the breech mechanism not easily accessible for cleaning.

b. Exercise care to prevent staves of sponges, slush brushes, and cleaning brushes from rubbing against the lower portion of the bore as excessive wear of the lands will result from such practice.

52. AZIMUTH AND ELEVATION DATA INDICATORS. a. **General.** The azimuth data indicator is located at the left front of the gun just ahead of the slow-motion handwheels. It is used to indicate the azimuth at which the gun is set and also the azimuth at which to set the piece when off-carriage fire control instruments are used. The elevation data indicator (fig. 26) is located on the

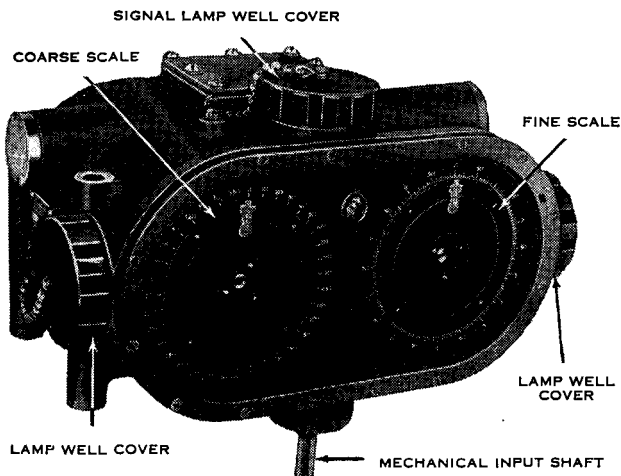

Figure 26. Elevation data indicator.

right side of the gun under the elevating hand-wheel. It is used to indicate the elevation at which the gun is set and also the elevation at which to set the gun as directed from the off-carriage fire control system.

b. Orientation. (1) To orient the azimuth and elevation data indicators, first set the gun at a known azimuth and elevation. This can be done, in azimuth, by boresighting on a known point or from the azimuth scale of the gun provided it has been adjusted previously. Elevation may be set with the use of a gunner's quadrant or a clinometer.

(2) Loosen the clamping screw on the zero adjusting device. The azimuth data indicator zero adjusting device is on the azimuth data indicator gear which is attached to the lower end of the azimuth data indicator drive shaft. The elevation data indicator zero adjusting device is between the indicator and the right side frame.

(3) Turn the adjusting worm on the zero adjusting device until the fine and coarse dials on the azimuth (or elevation) data indicator read the exact azimuth (or elevation) at which the gun is set.

(4) Tighten the clamping screw when the correct azimuth (or elevation) is set, making sure that it does not change while tightening.

c. Synchronization. (1) Synchronization is the setting of the electrical dials which receive the azimuth (or elevation) so that they indicate the same data that are set on the transmitters in the plotting room.

(2) Energize the system. This is usually done from the plotting room.

(3) Set the transmitter at a known value and check to see that the receiver indicates the same value. If it does not, adjust the indicator as in (4) below.

(4) Remove the signal lamp well cover and turn the slotted adjustment shafts until the dials

are properly set. The slotted adjustment shafts should not be forced against their stops. If sufficient adjustment cannot be made in this manner, or if there is a large error (often in a multiple of 60°) which indicates that there is a wiring fault, notify ordnance.

(5) Check synchronism at several points on the dial. Replace the signal lamp well cover.

d. Care and preservation. (1) Access to all lamps on the indicator is obtained through lamp well covers. There are 2 lamps under each cover. One is sufficient for the illumination if the other lamp burns out. The burned out lamps must be replaced with Mazda No. 51 type lamps (1 c.p., 6-8 volts, 0.2 ampere, G3-½ bulb).

(2) Should any repeater start to "run away" (run as a motor at a high rate of speed), cut off the power immediately and then reapply power after the repeater comes to rest. Repeaters are most likely to "run away" at the instant when power is applied.

(3) Should a repeater on either gun bind or stick during operation, turn off the power to that repeater by means of the switch in the main junction box.

SECTION VII

DEMOLITION OF EQUIPMENT

53. GENERAL PRINCIPLES. a. Tactical situations may arise when, due to limitations of time or transportation, it will become impossible to evacuate all equipment. In such situations it is imperative that all materiel which cannot be evacuated be destroyed to prevent—

(1) Its capture intact by the enemy.

(2) Its use by the enemy, if captured, against our own or allied troops.

(3) Its assembly by the enemy into complete units from salvaged parts.

b. The working principles to be followed are—

(1) Methods for the destruction of materiel subject to capture or abandonment in the combat zone must be adequate, uniform, and easily followed in the field.

(2) Destruction must be as complete as the available time, equipment, and personnel will permit. If thorough destruction of all parts cannot be completed, the parts essential to the operation or use of the materiel, particularly those which cannot be easily duplicated, should be destroyed or removed. *The same essential parts must be destroyed on all like units to prevent the enemy's constructing one complete unit from several damaged ones by "cannibalization."*

(3) The destruction of materiel, subject to capture or abandonment in the combat zone, *will be undertaken only when ordered by the harbor defense (or higher) commander.*

c. To accomplish adequate and uniform destruction of materiel, it is essential that—

(1) All echelons prepare plans for the destruction of materiel in the event of imminent capture. Such plans must be flexible enough to make allowance for variations in available time, equipment, and personnel.

(2) All echelons be trained to effect the desired destruction of materiel issued to them. *Training will not involve the actual destruction of materiel.*

d. Certain of the methods outlined require special tools and materials, such as TNT and incendiary grenades, which normally may not be items of issue. The issue of such special tools and materials, the materiel to be destroyed, and the conditions under which destruction will be effected are command decisions in each case, depending on the tactical situation.

54. PRIORITY OF DESTRUCTION. a. Destruction should be accomplished in the following priority:

(1) Tube, breech, and recoil mechanism.

(2) Power equipment.

(3) Carriage.

(4) Telescope and observation instruments.

(5) Plotting room equipment.

(6) Ammunition.

(7) Fire control and observation stations; magazines.

b. In the event of imminent capture, everything that could be of possible use to the enemy should be destroyed. If evacuation is probable, all telescopes, optical instruments, and other valuable small items should be evacuated.

55. TUBE. a. **General.** The selection of a method of demolition will depend on the tactical situation and the materials available. The methods for the destruction of the tube are presented in the order of their effectiveness.

b. Demolition by TNT blocks. (1) Drain the recoil cylinder by removing the caps on both the recoil cylinder filling valve and the tee in the pipe to the recoil cylinder expansion chamber, and by unscrewing the valve plug in the recoil cylinder filling valve.

(2) Insert 150 one-half pound TNT blocks in the chamber. Close the breechblock and plug the muzzle tightly to a distance of about three calibers (4 feet for this gun). Detonate the TNT charge by means of a detonating cord routed through the primer vent.

(3) Take cover when firing the charge. The danger space is about 500 yards.

(4) For instructions on the wiring and firing of TNT, see FM 5-25.

c. Demolition by TNT blocks and shell. Drain the recoil cylinder as in *b* preceding. Ram a shell (without base fuze) into the forcing cone, place 150 one-half pound TNT blocks in the chamber, and close the breechblock. Detonate the TNT with a detonating cord routed through the primer vent. Use a sufficient length of fuze to permit personnel to reach cover.

d. Demolition by incendiary grenades. If evacuation is imminent and it is desired to accomplish demolition without telltale explosions, this method should be used. Place 15 to 25 *unfuzed* M14 incendiary grenades in the chamber. They should be placed on their sides and stacked one on top of another. Close the breech. Equip another incendiary grenade with a 15-second Bickford fuze, ignite it, and throw it in the muzzle. Elevate the tube quickly to its maximum elevation.

56. BREECH. Any of the above methods for destroying the gun should also destroy the breech, but if the method selected does not destroy the breech, use a heavy sledge to render it useless.

57. RECOIL MECHANISM AND CARRIAGE.

If the methods given in paragraph 55 are used for destroying the tube, the resulting damage to the recoil mechanism and carriage should be effective in rendering them useless.

58. POWER EQUIPMENT. a. The power equipment of a 16-inch battery which will require destruction in the event of capture or evacuation includes—

(1) Elevating, traversing, and power rammer motors.

(2) Motor-driven air compressor.

(3) The auxiliary power plant.

b. Electric motors and generators can be most effectively and easily put out of operation by injuring the field or armature windings. If time is available, break the motor shell with a sledge and ruin the coils with a crowbar. If time is short, fire a small-arms bullet into the coils through the air vents of either end bell, but take care to keep personnel from the path of a ricochet. Completely smash with an ax or sledge the main switch panels in the power plant and all sockets, plugs, and fuse and circuit-breaker panels.

59. TELESCOPES AND OBSERVATION INSTRUMENTS. Evacuate telescopes and observation instruments if possible. If they cannot be evacuated, smash them thoroughly.

60. PLOTTING ROOM EQUIPMENT. Smash all boards and instruments and burn them if possible. Smash data transmitters and all communication equipment.

61. AMMUNITION. a. **Projectiles.** Stack horizontally separate-loading projectiles with ogive ends pointing in the same direction. Remove the fuze from the center shell in the top row of each

pile. Pack a detonating cap with a detonating cord attached next to the booster in each center shell and detonate. The danger zone is at least 200 yards. Shells standing on their bases cannot be satisfactorily destroyed by sympathetic detonation.

b. Powder. Separate-loading propelling charges can best be destroyed by burning. This is most effectively accomplished when they are out of their containers or the containers are split.

62. FIRE CONTROL AND OBSERVATION STATIONS; AMMUNITION MAGAZINES. **a.** These installations can best be destroyed by demolition with TNT.

b. See FM 5-25 for details of demolition planning and execution.

APPENDIX I

LIST OF REFERENCES

AMMUNITION

- Coast Artillery AmmunitionTM 4-205
Ammunition, GeneralTM 9-1900

CARE AND MAINTENANCE OF MATERIEL

- Service of the Piece, 16-inch Gun and
HowitzerFM 4-85
Preservation and Care of Seacoast Defense
MaterielTM 4-245
16-inch Seacoast Materiel, Gun Mk. II M1,
Barbette Carriage M4TM 9-471
Cleaning, Preserving, Lubricating, and
Welding Materials and Similar Items
Issued by Ordnance DepartmentTM 9-850

COMMANDS

- TacticsFM 4-5
Firing Preparations, Safety Precautions,
Care and Service of MaterielFM 4-20

DEFENSIVE MEASURES

- TacticsFM 4-5
Firing Preparations, Safety Precautions,
Care and Service of MaterielFM 4-20
Camouflage, Basic PrinciplesFM 5-20
Defense Against Chemical AttackFM 21-40
DecontaminationTM 3-220
Protective Concealment for Seacoast
FortificationsTM 5-265

DEMOLITION

- Explosives and DemolitionsFM 5-25
Military ExplosivesTM 9-2900

DICTIONARY

Dictionary of United States Army Terms..TM 20-205

EXAMINATIONS

Examinations for GunnersFM 4-19

FIRE CONTROL AND POSITION FINDING

Fire Control and Position FindingFM 4-15

FIRING TABLES

Firing Tables for Gun, 16-inch, Mk. II,
NavyFT 16-E-1

Firing Tables for Gun, 16-inch, Mk. II
M1, NavyFT 16-D-1

Firing Tables for 16-inch Gun M1919,
M1919MII, and M1919MIIIFT 16-B-1

GUN DATA TRANSMISSION AND COMPUTER SYSTEMS

Service of the Gun Data Computer M1 ...FM 4-30

Service of the Base-end Data and Gun
Data Transmission SystemsFM 4-32

ORGANIZATION OF BATTERY

TacticsFM 4-5

Coast Artillery Battery, Gun, Harbor
DefenseT/O 4-67

SAFETY PRECAUTIONS

Firing Preparations, Safety Precautions,
Care and Service of MaterielFM 4-20

Range Regulations for Firing Ammunition
for Training and Target PracticeAR 750-10

SEACOAST ARTILLERY GUNNERY

GunneryFM 4-10

SEACOAST ARTILLERY MATERIEL

Coast Artillery Weapons and MaterielTM 4-210

TARGET PRACTICE

Seacoast Artillery Target PracticeTM 4-235

APPENDIX II

STATISTICAL DATA

GUN, 16-INCH NAVY MK. II M1.

Caliber	16 in.
Length of bore	50 cal.
Length (muzzle to rear face of breech ring)	816 in. (68 ft.)
Travel of projectile in barrel	681.68 in.
Rifling:	
Length	675.992 in.
Number of lands	96
Twists:	
Direction	right-hand
Degree in cal.	1 in 32 cal.
Type	uniform
Weight of gun without band	285,985 lb.
Weight of gun with band	307,185 lb.
Capacity of powder chamber	30,000 cu. in.

CARRIAGE, 16-INCH M4.

Maximum traverse	145 deg.
Maximum elevation	46 deg.
Maximum depression	3 deg.
Normal recoil	48 in.
Maximum recoil	49 in.
Total dead load on emplacement ..	1,172,500 lb.
Weight of carriage without shield.	665,315 lb.
Weight of tipping parts, including gun and band	385,377 lb.
Weight of recoiling parts, including gun and band	316,853 lb.
Weight of the shield (4-in. cast) estimated	200,000 lb.

CARRIAGE, 16-INCH M4 (Contd.).

Elevating mechanism right side, one turn of handwheel counter- clockwise elevates the gun	56.509 min.
Elevating mechanism left side, one turn of handwheel counter- clockwise elevates the gun	2 deg. 56.897 min.
One turn of slow-motion hand- wheel traverses gun	0.1098 deg.
One turn of traversing crank trav- erses gun	1.5384 min.
Capacity of recoil cylinder	73 gal.
Normal air pressure in recupera- tor	1,700 lb. per sq. in.
Air pressure in recuperator, maxi- mum recoil	3,090 lb. per sq. in.
Normal liquid pressure in re- cuperator	1,824 lb. per sq. in.
Liquid pressure in recuperator, maximum recoil	3,348 lb. per sq. in.

AMMUNITION.

Weight of projectile Mk. XII, AP . . .	2,240 lb.
Weight of projectile Mk. II M2, AP	2,100 lb.
Weight of powder charge, full charge	672 lb.
Muzzle velocity, Mk. XII projec- tile	2,650 ft. per sec.
Muzzle velocity, Mk. II M2 projec- tile	2,750 ft. per sec.
Range (46° elevation), Mk. XII projectile	45,100 yd.
Range (46° elevation), Mk. II M2 projectile	44,670 yd.
Chamber pressure	38,000 lb. per sq. in.

APPENDIX III

DRILL TABLE

Service of the piece, 16-inch gun, casemated

Details	DETAILS, POSTS ¹	(a) EXAMINE GUN (EQUIPMENT) ² (b) REPORT	TARGET
Gun commander.	Gives command when necessary. Sees that the air compressor is started, set for continuous operation, and working properly. Takes post at gun commander's push button, alert to the supervision of his detail.	(a) Gives command when necessary. Inspects the gun, carriage, and other materiel, giving particular attention to the recoil and recuperator systems, firing mechanism, recoil parts lock and other safety devices, and the oiling of various bearings. (b) Receives all reports from the gun squad and reports to the chief of section, "No. in order," or any defects he is unable to remedy without delay.	Repeats command and target designation. In case II firing, assists the gun pointer in getting on the correct target. Reports through the telephone operator to the battery commander, "Sir, No. on target."
Gun pointer.	Starts the traversing gear motor and takes post at left trunnion, facing to the rear. ³	(a) Checks the adjustment, orientation, and serviceability of the azimuth data indicator and telescope mount if so equipped; tests both the power and hand traversing mechanisms; and checks the communications to the plotting room. (b) Reports to the gun commander, "Traversing in order," or any defects he is unable to remedy without delay.	As soon as data are available, starts tracking the target by matching pointers. (Data are not correct until the red light is on.) In case II firing, gets on target with telescope and sets deflections as soon as they are available.

¹ All men should take their posts on the alert signal. A verbal order is not necessary.

² The details listed under EXAMINE GUN (EQUIPMENT) are performed twice daily, morning and evening, and this command is not necessary when preparing for combat.

³ If a telescope sight is available and if conditions permit and indicate case II firing, the telescope should be mounted.

LOAD	COMMENCE FIRING (RESUME FIRING)	(a) CEASE FIRING (b) SUSPEND FIRING
<p>Gives command and supervises work of his squad.</p>	<p>In case III firing, fires the gun after elevation setter calls, "Set." ⁴ In case II firing, where there is a firing key on the slow-motion handwheel, presses firing button, and calls, "Ready."</p>	<p>(a) Repeats command and supervises the duties of the gun squad. Holds the gun squad ready to continue firing until the command REPLACE EQUIPMENT is given.⁵ (b) Repeats command. If the gun is unloaded, causes it to be loaded and holds fire until he receives the command RESUME FIRING. (a) and (b) If the gun is loaded, causes all personnel to keep away from the gun commander's push button. If the gun is equipped with firing magnetos, causes personnel to keep away from them. If firing by lanyard, causes lanyard to be detached.</p>
<p>Continues to track target. If the pointers are not matched, if the red light is out, or if the gun is not on target when the elevation setter indicates that the elevation is set, commands: CEASE FIRING.</p>	<p>In case III firing, keeps pointers matched at all times. Fires the gun in case II pointing, after the gun commander calls, "Ready." ⁶</p>	<p>(a) and (b) Continues to keep pointers matched or gun on target until the command CEASE TRACKING is given.</p>

⁴ In some cases, the only firing magnetos will be at each slow-motion handwheel. On these guns when case III firing is being used, No. 4, the brake operator, will fire the gun from the magneto at the right side of the gun on the command FIRE given by the gun commander.

⁵ The gun commander sees that the air compressor is stopped or placed on automatic operation (par. 28) on the command REPLACE EQUIPMENT.

⁶ See subparagraph 29c.

DRILL TABLE.—Service of the piece,

Details	DETAILS, POSTS ¹	(a) EXAMINE GUN (EQUIPMENT) ² (b) REPORT	TARGET
Elevation setter.	Starts the elevating gear motor and takes post beside the follow-up control handwheel, facing to the rear.	(a) Checks the adjustment, orientation, and serviceability of the elevation data indicator; tests both the power and hand elevating mechanisms; and checks the communications to the plotting room. (b) Reports to the gun commander, "Elevation in order," or any defects he is unable to remedy without delay.	Brings the gun to the load position.
Telephone operator.	Procures head and chest sets, and connects them to field telephone. Takes post at battery commander's telephone station and tests communications.	(a) Checks and cleans equipment. (b) Reports to the gun commander, "Telephone in order," or any defects he is unable to remedy without delay.	Transmits the command.
Chief of breech.	Posts his detail after assuring himself that each man has procured the necessary cleaning material and equipment. Removes the recoil parts lock when so directed by the gun commander. Takes his post outside the right side frame near the breech, facing to the rear.	(a) Supervises the examination and servicing of the breech mechanism, firing mechanism, breech recess, chamber, bore, and rammer and assists where he can; checks to insure that everything is in proper working order. (b) Reports to the gun commander, "Breech in order," or any defects he is unable to remedy without delay.	Sees that the breech of the gun is open and prepared for loading.

16-inch gun, casemated—(Continued)

LOAD	COMMENCE FIRING (RESUME FIRING)	(a) CEASE FIRING (b) SUSPEND FIRING
<p>After the gun has been loaded, the breech closed, and when the chief of breech commands: ELEVATE, elevates the gun.</p>	<p>Sets the outer index slightly ahead of the inner index and calls, "Elevation." Sees that the brakes are set. When the two indexes are exactly matched, calls, "Set." After the gun has been fired, returns it to the load position.</p>	<p>(a) Brings the gun to the load position and remains at post. Turns off the elevating motor when CEASE TRACKING is given. (b) Brings the gun to load position if the chamber is empty. When the gun is loaded, continues to match pointers.</p>
<p>Transmits the command...</p>	<p>Transmits the command...</p>	<p>(a) and (b) Transmits all commands.</p>
<p>Supervises the details of loading. As soon as the primer has been inserted and all personnel are clear of the breech of the gun, commands: ELEVATE.</p>	<p>No duties.....</p>	<p>(a) If the round is in the chamber, notifies the gun commander. (The executive officer will supervise the unloading by firing the gun when the field of fire is safe.) Supervises the duties of his detail and remains at post. (b) If the chamber of the gun is empty, supervises the loading and commands: ELEVATE as soon as all personnel are clear of the breech.</p>

DRILL TABLE.—Service of the piece,

Details	DETAILS, POSTS ¹	(a) EXAMINE GUN (EQUIPMENT) ² (b) REPORT	TARGET
No. 1 (Breech detail).	Procures cotton waste; assisted by No. 2, removes the breech cover; takes post on right side of the loading platform, facing to the rear.	(a) Examines, cleans, and oils the breech mechanism; and assists in cleaning and oiling the bore and chamber when necessary. (b) No duties.	Assists No. 2 in opening the breechblock; sees that the breechblock is latched open; and assists in the lowering of the loading trough into the load position.
No. 2 (Breech detail).	Procures cotton waste; assists No. 1 in removing the breech cover; takes post on the left side of the loading platform, facing to the rear.	(a) Assists No. 1 and assists the air pressure operator in checking the breech air system. (b) No duties.	Assisted by No. 1, opens the breechblock and lowers the loading trough into the breech recess.
No. 3 (Breech detail).	Procures the firing lock, primers, primer pouch, drill, reamer, and cotton waste; takes post at the step just outside the right side frame, facing to the rear.	(a) Examines, cleans, and oils the firing lock; tests the electrical firing circuit; cleans the vent and primer seat. (b) No duties.	No duties

LOAD	COMMENCE FIRING (RESUME FIRING)	(a) CEASE FIRING (b) SUSPEND FIRING
<p>After the ramming of the projectile and powder is completed, withdraws and raises the loading trough. Assists in the closing of the breechblock; crosses the platform, seeing that the breech-operating lever handle is latched; opens the firing lock; and passes off the left side of the loading platform. If the air pressure fails, assists No. 2 in closing and locking the breechblock by hand.⁷</p>	<p>After the gun has been fired and returned to the load position, immediately moves onto the loading platform and assists No. 2 with the opening of the breechblock, paying particular attention to see that the fired primer is fully ejected from the firing lock. Looks through the bore of the gun and when daylight can be seen or when the flame disappears, closes the gas-ejector valve and calls, "Bore clear." Wipes off the mushroom head while the piece is being loaded.</p>	<p>(a) If the round is in the chamber, remains clear of the breech with no duties. If piece is unloaded, wipes off the mushroom head and breechblock, and remains at post. (b) If the chamber is empty, performs duties relative to loading.</p>
<p>After the projectile and powder have been rammed, with the right foot kicks the holding-down latch tripping handle to release the catch holding the breechblock open.⁸ Then trips the closing valve and moves off the loading platform to the rear.⁷ If the air pressure fails, assisted by No. 1, closes and locks the breechblock by hand.</p>	<p>After the gun has been fired, follows No. 1 onto the platform, opens the breechblock, and lowers the loading trough.</p>	<p>(a) No duties if the round is in the chamber. Remains clear of the breech. If the piece is unloaded, assists in wiping off the breechblock. Lowers the loading trough into place, and remains at post. (b) If the chamber is empty, proceeds as under the command LOAD.</p>
<p>While the breechblock is being closed, moves over the side frame to the loading platform, brushes the primer seat, inserts a primer into the primer seat, and moves the firing lock slide over the primer. Then, moves off the platform to the left and takes post at the right side frame.</p>	<p>Fires the gun on gun commander's order when it is necessary to use lanyard.</p>	<p>(a) No duties if the round is in the chamber. Remains clear of the breech. If the chamber is empty, inspects and wipes off the firing lock with cotton waste. Takes post outside the right side frame. (b) When the gun is reloaded, inserts the primer and moves off the platform.</p>

⁷ If (as in some cases) the breech-closing valve is on the right side of the breech, No. 1 will operate it as soon as the loading trough is clear.

⁸ On the M1919MII and M1919MIII guns there is no holding-down latch.

Details	DETAILS, POSTS ¹	(a) EXAMINE GUN (EQUIPMENT) ² (b) REPORT	TARGET
No. 4 (Brake operator).	Raises the brake-release levers while the elevating gear motor is being started and lowers them after the motor has reached full speed. Takes post next to the brake-release levers, facing to the rear.	(a) Assists the elevation setter in the examination of the elevating mechanisms. (b) No duties.	On a signal from the elevation setter, raises the brake-release levers to release the brakes so that the gun can be brought to the load position. Drops the brake-release levers as soon as gun is in loading position.
No. 5 (Rammer detail).	Starts the rammer gear motor and takes post at the left rear of the ammunition parking table, facing to the rear.	(a) Examines, cleans, and checks the adjustment of rammer and spanner tray. Lubricates the spanner tray chain and sprocket. (b) Reports to the gun commander, "Rammer in order," or any defects he is unable to remedy without delay.	No duties.....
No. 6 (Projectile serving detail).	Removes the muzzle cover assisted by No. 7, and takes post at the right front of the ammunition parking table, facing to the rear.	(a) When needed, procures the bore greasing device, rope, and other bore cleaning equipment. Cleans and replaces this equipment after using. (b) No duties.	Assists the ammunition detail in the placing of one projectile in the loading trough and assists wherever possible without leaving post.

16-inch gun, casemated—(Continued)

LOAD	COMMENCE FIRING (RESUME FIRING)	(a) CEASE FIRING (b) SUSPEND FIRING
<p>On the command ELEVATE given by the chief of breech, raises the brake-release levers to release the brakes so that the gun can be elevated. As soon as the elevation setter signals or calls, "Elevation," drops the brake-release levers.</p>	<p>In case III firing, when firing magneto is being used, fires gun upon gun commander's order.⁴</p>	<p>(a) and (b) Releases or applies the brake as directed by the elevation setter. Remains at post.</p>
<p>Moves the rammer control lever to the RAM position; rams the projectile into the chamber of the gun; withdraws the rammer. When half of the powder charge is in the loading trough, moves it forward out of the way; withdraws the rammer. When the other half of the powder charge is in place, rams the powder into the chamber of the gun (par. 23<i>d</i>) and withdraws the rammer.</p>	<p>No duties</p>	<p>(a) Remains at post. When the command CEASE TRACKING is given, sees that the rammer gear motor is turned off. (b) Rams the projectile and powder into the gun if the chamber is empty.</p>
<p>Assists the ammunition detail in the placing of the next projectile on the parking table. Rolls the second projectile into the loading trough as soon as the ramming of the first round is complete.</p>	<p>Sees that there is a projectile in the loading trough when or immediately after the gun is fired.</p>	<p>(a) Remains at post. (b) Continues to feed projectiles into the loading trough.</p>

⁴ In some cases, the only firing magnetos will be at each slow-motion handwheel. On these guns when case III firing is being used, No. 4, the brake operator, will fire the gun from the magneto at the right side of the gun on the command FIRE given by the gun commander.

DRILL TABLE.—Service of the piece,

Details	DETAILS, POSTS ¹	(a) EXAMINE GUN (EQUIPMENT) ² (b) REPORT	TARGET
No. 7 (Ammunition serving detail).	Assists No. 6 in removing the muzzle cover and takes post at the left front of the ammunition parking table, facing to the rear.	(a) Assists where necessary. (b) No duties.	Assists the ammunition detail in getting the powder charge for the first round in place ready to be placed in the loading trough.
Chief of ammunition.	Gives command when necessary.	(a) Gives command when necessary. Supervises and assists in the examination of the ammunition and ammunition handling equipment. Ascertains that sufficient equipment to maintain continuous service of ammunition to the gun is in proper working order. (b) Reports to the chief of section, "Ammunition service in order," or any defects he is unable to remedy without delay.	Supervises the service of ammunition to the gun position.
Nos. 8 through 35 (Ammunition detail).	Open the powder magazines and projectile rooms and stand by positions as posted by the chief of ammunition.	(a) Examine and prepare the ammunition and the ammunition handling equipment for service or drill. (b) No duties.	Serve ammunition to the gun position.

16-inch gun, casemated—(Continued)

LOAD	COMMENCE FIRING (RESUME FIRING)	(a) CEASE FIRING (b) SUSPEND FIRING
<p>Assists the ammunition detail in placing the powder charge on the parking table. After the projectile has been rammed and the rammer withdrawn, rolls the powder charge into the loading trough, three bags at a time.</p>	<p>Sees that the powder charge is not brought near the gun until after No. 1 calls, "Bore clear."</p>	<p>(a) Remains at post. (b) Continues to serve powder into the loading trough.</p>
<p>Supervises the service of ammunition to the gun position.</p>	<p>Supervises the service of ammunition to the gun position.</p>	<p>(a) Sees that all powder is taken away from the gun position and put into a safe place. Sees that the members of the ammunition detail remain at posts. (b) Supervises the service of ammunition to the gun position.</p>
<p>Continue to serve ammunition to the gun position.</p>	<p>Continue to serve ammunition to the gun position.</p>	<p>(a) Move all powder back into the powder magazine or to some safe place as directed by the chief of ammunition and remain at posts. (b) Continue to serve ammunition to the gun position.</p>